



INTERNATIONAL APPLICATION PUBLISHED UNDER THE PATENT COOPERATION TREATY (PCT)

<p>(51) International Patent Classification <sup>6</sup> : <b>G01H 9/00</b></p>	<p><b>A1</b></p>	<p>(11) International Publication Number: <b>WO 99/15863</b> (43) International Publication Date: 1 April 1999 (01.04.99)</p>
<p>(21) International Application Number: PCT/IL97/00313 (22) International Filing Date: 24 September 1997 (24.09.97)  (71) Applicant (for all designated States except US): 3DV SYSTEMS, LTD. [IL/IL]; P.O. Box 249, 20692 Yokneam (IL).  (72) Inventors; and (75) Inventors/Applicants (for US only): YAHAV, Giora [IL/IL]; Beiliss Street 11, 34814 Haifa (IL). SCHUSTER, Israel [IL/IL]; Ha'Gomme Street 13, 36090 Kiryat Tivon (IL).  (74) Agents: FENSTER, Paul et al.; Fenster &amp; Company, Patent Attorneys, Ltd., P.O. Box 2741, 49127 Petach Tikva (IL).</p>		<p>(81) Designated States: JP, US, European patent (AT, BE, CH, DE, DK, ES, FI, FR, GB, GR, IE, IT, LU, MC, NL, PT, SE).  <b>Published</b> <i>With international search report.</i></p>

(54) Title: ACOUSTICAL IMAGING SYSTEM

(57) Abstract

An acousto-optic imaging system (18) for imaging an object including a source of acoustic energy which illuminates the object; an acousto-optic imaging plate (10) which receives scattered acoustic energy from the object, said scattered acoustic energy (37) forming an acoustic image at the acousto-optic imaging plate (10), a source of optical energy (22) which produces optical energy whose characteristics are modified by changes in the acousto-optic imaging plate (10) caused by the received acoustic energy (37); and an optical imager (32) which forms a nonholographic image of modified optical energy. The source of acoustic energy is pulsed such that the intensity of the time integral of light detected by the optical imager (32) is an image having a spatially varying intensity. The intensity at a point in the optical image is related to the distance from a reference position of a corresponding point in the object.

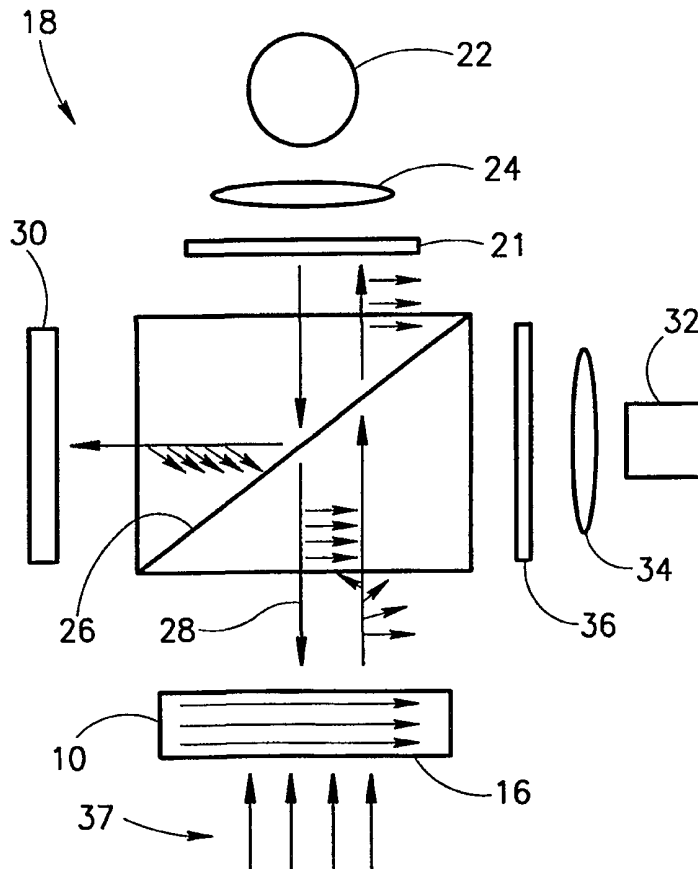

**FOR THE PURPOSES OF INFORMATION ONLY**

Codes used to identify States party to the PCT on the front pages of pamphlets publishing international applications under the PCT.

<b>AL</b>	Albania	<b>ES</b>	Spain	<b>LS</b>	Lesotho	<b>SI</b>	Slovenia
<b>AM</b>	Armenia	<b>FI</b>	Finland	<b>LT</b>	Lithuania	<b>SK</b>	Slovakia
<b>AT</b>	Austria	<b>FR</b>	France	<b>LU</b>	Luxembourg	<b>SN</b>	Senegal
<b>AU</b>	Australia	<b>GA</b>	Gabon	<b>LV</b>	Latvia	<b>SZ</b>	Swaziland
<b>AZ</b>	Azerbaijan	<b>GB</b>	United Kingdom	<b>MC</b>	Monaco	<b>TD</b>	Chad
<b>BA</b>	Bosnia and Herzegovina	<b>GE</b>	Georgia	<b>MD</b>	Republic of Moldova	<b>TG</b>	Togo
<b>BB</b>	Barbados	<b>GH</b>	Ghana	<b>MG</b>	Madagascar	<b>TJ</b>	Tajikistan
<b>BE</b>	Belgium	<b>GN</b>	Guinea	<b>MK</b>	The former Yugoslav Republic of Macedonia	<b>TM</b>	Turkmenistan
<b>BF</b>	Burkina Faso	<b>GR</b>	Greece	<b>ML</b>	Mali	<b>TR</b>	Turkey
<b>BG</b>	Bulgaria	<b>HU</b>	Hungary	<b>MN</b>	Mongolia	<b>TT</b>	Trinidad and Tobago
<b>BJ</b>	Benin	<b>IE</b>	Ireland	<b>MR</b>	Mauritania	<b>UA</b>	Ukraine
<b>BR</b>	Brazil	<b>IL</b>	Israel	<b>MW</b>	Malawi	<b>UG</b>	Uganda
<b>BY</b>	Belarus	<b>IS</b>	Iceland	<b>MX</b>	Mexico	<b>US</b>	United States of America
<b>CA</b>	Canada	<b>IT</b>	Italy	<b>NE</b>	Niger	<b>UZ</b>	Uzbekistan
<b>CF</b>	Central African Republic	<b>JP</b>	Japan	<b>NL</b>	Netherlands	<b>VN</b>	Viet Nam
<b>CG</b>	Congo	<b>KE</b>	Kenya	<b>NO</b>	Norway	<b>YU</b>	Yugoslavia
<b>CH</b>	Switzerland	<b>KG</b>	Kyrgyzstan	<b>NZ</b>	New Zealand	<b>ZW</b>	Zimbabwe
<b>CI</b>	Côte d'Ivoire	<b>KP</b>	Democratic People's Republic of Korea	<b>PL</b>	Poland		
<b>CM</b>	Cameroon	<b>KR</b>	Republic of Korea	<b>PT</b>	Portugal		
<b>CN</b>	China	<b>KZ</b>	Kazakistan	<b>RO</b>	Romania		
<b>CU</b>	Cuba	<b>LC</b>	Saint Lucia	<b>RU</b>	Russian Federation		
<b>CZ</b>	Czech Republic	<b>LI</b>	Liechtenstein	<b>SD</b>	Sudan		
<b>DE</b>	Germany	<b>LK</b>	Sri Lanka	<b>SE</b>	Sweden		
<b>DK</b>	Denmark	<b>LR</b>	Liberia	<b>SG</b>	Singapore		
<b>EE</b>	Estonia						

ACOUSTICAL IMAGING SYSTEM**FIELD OF THE INVENTION**

The present invention is in the field of acoustical imaging systems and especially the field of three dimensional acoustical imaging systems.

5

**BACKGROUND OF THE INVENTION**

Acoustical imaging is a well developed field whose main utility is in the fields of medical imaging, nondestructive testing and underwater imaging. In general, acoustic imaging is based on the transmission of a beam of acoustic energy in the direction of an object to be imaged and its receipt by a directional antenna, such as a phased array of acoustic detector  
10 elements. In general therefore, in order to scan a three dimensional object, it is necessary to scan the beam in two cross dimensions.

Some systems, utilize a phased array with a large number of elements, a broad beam transmission and a multidirectional receiving antenna. Based on multiple circuits which provide a plurality of sums of acoustic energy received by the individual elements, each said sum  
15 corresponding to a different receiving antenna direction, the systems can supply a number of receiving beams from a single transmission beam. However, in order to provide three dimensional images, either the transmitted beam or the direction of the beam of the receiving antenna (generally both) must be scanned in two or three dimensions.

While focusing of the transmitted beam and/or the receiving antenna at a particular,  
20 generally variable, distance is not, strictly speaking, required, it is often provided to improve the image quality and to reduce the effects of reflections and off angle reflections.

Furthermore, systems which provide multiple receiving beams are very expensive if more than a few such beams are to be provided.

Therefore, in general, acoustic three dimensional imaging systems are generally slow  
25 and/or of low resolution, consistent with the requirement that a large number of acoustic waves be transmitted for each image in a relatively short time period.

Systems have been reported which provide an acoustic image utilizing a single broad beamed transmission of acoustic energy for each image. Such systems as described in U.S. Patent 4,393,712, the disclosure of which is incorporated herein by reference, utilize an acoustic  
30 lens to focus acoustic energy on an acousto-optical converter and viewing the optical image. The Background of the invention portion of this patent discloses and refers to a variety of

acousto-optical imaging devices. However, since there is no reported method of determining depth, such systems have not gained wide use for practical applications.

US Patent 4,338,821, the disclosure of which is incorporated herein by reference, describes a system for acousto-optical imaging is described in which an optical holographic image is generated, utilizing a liquid crystal (LC) image plate which converts acoustic energy to an optical image.

US Patent 4,379,408, the disclosure of which is incorporated herein by reference, describes systems for optical imaging of acoustic waves utilizing LC devices. Visualization of both transmitted and reflected acoustic waves is described.

In PCT Publications WO97/01111, WO97/01112, WO97/01113 the disclosures of which are incorporated herein by reference, a system of determining depth of an object in an entire optical image based on the reflection by the object of gated optical illumination of the object. In one method described in these patent applications, depth is determined based on the brightness of an image which is formed by gating the reflected light.

"Ultrasonic Switching of a bistable liquid crystal cell" by W. Hamidzada and S.V. Letcher (Appl. Phys. Lett. 42(9) May 1983, Pages 785-786) describes the biasing of an LC cell such that acoustic energy above a threshold, controlled by the bias, causes the cell to change its polarization state.

US Patents 3,837,423; 4,506,550 and 4,652,086 as well as "A New Liquid Crystal Acoustical-to-Optical Display" by P. Greuguss (ACOUSTICA, v. 29, (1972) pages 52-58) the disclosures of all of which are incorporated herein by reference, describe various types of LC cells suitable for conversion of acoustic waves to optical images as well as methodologies of imaging using such cells. "A new hypothesis on ultrasonic interaction with a nematic liquid crystal" by J.L. Dion and A.D. Jacob, (Appl. Phys. Lett. 31(8) 15 Oct 1997 Pages 490-493) and "Acousto-Optical Effect in a Nematic Liquid Crystal" by S. Nagai, A Peters and S Candau (Revue de Physique Appliquee, vol. 12, p. 21 (1977) describe a theory for the interaction between an acoustic field and an LC. Both these papers are incorporated herein by reference.

### SUMMARY OF THE INVENTION

It is the purpose of some aspects of the present invention to provide means and methods for converting acoustic energy scattered from an object to a three dimensional image.

In some preferred embodiments of the invention the outer surface of the object can be imaged utilizing a single pulsed illuminating acoustic beam. Alternatively, higher resolution may be achieved by transmitting a series of such beams.

5 In some preferred embodiments of the invention the internal structure of an object may also be viewed by sequentially viewing "slices" of the object at varying distances utilizing a plurality of illuminating acoustic beams.

10 In preferred embodiments of the invention, an object is illuminated by an acoustic beam and the acoustic energy is reflected from the object toward an acousto-optic converter (AOC) such as biased LC plates as described in the prior art. The illuminating acoustic beam is preferably pulsed. Thus, leading edge of acoustic beams reflected from the various portions of the object arrive at the converter at times which are substantially proportional to the sum of the distances which the illuminating and reflected beams travel. While LC plates are preferred the invention can utilize other forms of acousto-optical converter (AOC).

15 The AOC plates are preferably gated on and off in a timed relationship with the illuminating pulses. The AOC plate will then cause light to be produced, at a sensor, when it is gated on and when sufficient acoustic energy is received to turn on portion of the converter which is illuminated. Thus if a AOC is gated from a time  $t_0$  to a time  $t_1$  and the acoustic beam reaches a portion of the converter at a time  $t_2$  (between  $t_0$  and  $t_1$ ) the integrated image brightness related to that portion will be proportional to  $t_1 - t_2$ . In this way the brightness of the optical energy detected from the acousto-optic converter will be proportional to the time within the gate that the reflected wave is present at the converter with sufficient energy to activate the converter. The brightness of a portion of the resulting image will thus indicate the distance of the portion of the object which is imaged at the portion of the converter associated with the particular portion of the image from a reference.

25 Since, in general, for some embodiments of the invention, the state of the converter will be switched when the acoustic energy passes a threshold and will remain switched so long as the energy is above the threshold, the above described embodiment of the invention indicates the outside surface of the object.

30 In another preferred embodiment of the invention, image slices of the object are acquired serially. In this embodiment of the invention the illumination energy is made brief enough such that the extent of reflections which it provides is within a given slice of the object. For time before or after the expected time of arrival of the reflected wave from portions of the

wave within the slice, the cell is gated off. The combination of gating and time of arrival of the pulse is then utilized, in a manner similar to that indicated above, to measure the position of features within the slice.

In one variation of the invention, the image is viewed using a CCD camera. When a color CCD camera is used, different gated light sources can be used for serial acquisition of spaced slices of the object using a single pulse of acoustic illumination. Each of the slices is acquired using a different color source and a different (associated) one of the RGB channels of CCD. In general, the AOC is reset between slices so that the effect of the previous slice on the condition of the AOC is removed. This allows for the acquisition of complete three dimensional information regarding an object in one third the time. This makes it feasible to image moving objects, such as the heart in "real time" at relatively high frame rates with good resolution.

In another variation of the invention, the acoustic threshold can be varied between multiple pulsed illuminations such that the systems sensitivity to low variations in acoustic impedance may be varied. This allows for distinguishing between objects which are acoustically different.

There is thus provided, in accordance with a preferred embodiment of the invention, an acousto-optic imaging system for imaging an object comprising:

- (a) a source of acoustic energy which illuminates the object;
- (b) an acousto-optic imaging plate which receives scattered acoustic energy from the object, said scattered acoustic energy forming an acoustic image at the acousto-optic imaging plate;
- (c) a source of optical energy where a property of the energy (for example its polarization or its amplitude) is modified by changes in the acousto-optic imaging plate caused by the received acoustic energy; and
- (d) an optical imager which forms a nonholographic image of modified optical energy, wherein the source of acoustic energy is pulsed such that the intensity of the time integral of light detected by the optical imager is an image having an spatially varying intensity wherein the intensity at a point in the optical image is related to the distance from a reference position of a corresponding point in the object.

Preferably, the source of acoustic energy does not scan the object laterally to the direction of propagation of the illuminating acoustic energy.

In one preferred embodiment of the invention the optical image is an image of points on the surface of the object. Preferably, the source of optical energy is pulsed off only after acoustic energy scattered by the surface to be imaged reaches the acousto-optic image plate.

5 In an alternative preferred embodiment of the invention, the image is an image of the distance of points in a slice of the object from the reference position. Preferably, the imaging system includes a control system which applies a voltage operative to select either a high acoustic threshold state or a low acoustic threshold state of the acousto optic imaging plate. Preferably, the high acoustic threshold state is selected for time prior to a time of receipt of acoustic energy scattered from objects at the portion of the slice nearest the acousto-optical  
10 imaging plate and is changed to the low acoustic threshold state at said time of receipt, such that the time of said change defines the near distance of the image slice. Preferably the source of optical energy is pulsed off to define the far distance of the image slice.

In a preferred embodiment of the invention, the reference position is a distance corresponding to a scattered wave which is received at the time the optical energy is pulsed off.  
15 Preferably, the spatially varying intensity is proportional to the distance of a point in the acoustic imager from the reference position.

In a preferred embodiment of the invention, the intensity values are corrected by a normalization function derived by optically illuminating the acousto-optical plate from the source for a given time period during which the optical energy is modified by changes in the  
20 acousto-optical imaging plate.

In a preferred embodiment of the invention the source of light is linearly polarized and in which the acousto-optical plate does not affect the polarization of the optical energy prior to said change and in which the polarization is converted to elliptical polarization after said change. Preferably, the imager responds to the component of the light which has a polarity  
25 different from the polarity of light produced by the source.

In a preferred embodiment of the invention, the optical imager is a CCD camera.

In a preferred embodiment of the invention the acousto-optical imaging plate is a bistable device

In a preferred embodiment of the invention, the imaging plate is a liquid crystal plate.

30 There is further provided, in accordance with a preferred embodiment of the invention, a method of imaging an object, comprising:

illuminating the object with a pulse of acoustic energy;

forming an acoustic image, at an acousto-optic imaging plate, of said acoustic energy after scattering thereof by points in a first slice of the object;

forming an acoustic image, at the acousto-optic imaging plate, of said acoustic energy after scattering thereof by points in at least one additional slice of the object; and

5 separately detecting, by an optical imager of light modified by the first and at least one additional acoustic images to form a plurality of optical images from the pulse of acoustic energy,

wherein the intensity of the optical images have a spatially varying value related to the distance from a reference position of a corresponding point in the respective slice.

10 Preferably, the method includes:

sequentially illuminating the acousto-optical imaging plate with pulsed light of different colors; and

sequentially detecting said pulsed light of different colors to form said plurality of optical images each representative of one of said slices.

15 In a preferred embodiment of the invention, the acousto-optical imaging plate can be switched from a first state in which it is not sensitive to said scattered energy to a second state in which it is modified by said scattered energy and the method includes:

20 switching the state of the acousto-optical imaging plate from said first state to said second state when scattered energy from each of the respective slices first reaches the imaging plate.

Preferably, the method includes extinguishing the source of optical energy when scattered energy from the furthest portion of the respective slices reaches the imaging plate.

25 In a preferred embodiment of the invention the optical imager has a plurality of color channels each sensitive to a different color and wherein the colors of the illuminating light corresponds to the respective colors of the color channels.

Preferably, the optical image intensity of the formed images corresponds to intensity of the time integral of light detected by the optical imager.

In preferred embodiments of the invention the scattered acoustic energy is acoustic energy reflected by the object.

30



### BRIEF DESCRIPTION OF THE DRAWINGS

The invention will be more clearly understood in the context of the following explanation of preferred, non-limiting, embodiments thereof, taken in conjunction with the drawings in which:

5 Fig. 1 schematically illustrates the operation of a liquid crystal acousto-optic converter useful in preferred embodiments of the invention;

Figs. 2A and 2B show the effect of acoustic waves on light reflected by a liquid crystal acousto-optic converter in accordance with a preferred embodiment of the invention;

10 Fig. 3 is a schematic illustration of an acousto-optic imaging system in accordance with a preferred embodiment of the invention; and

Fig. 4 shows a timing diagram of an acousto-optic imaging system in accordance with a first preferred embodiment of the invention;

Fig. 5 shows an object which can be imaged utilizing some preferred embodiments of the present invention; and

15 Figs. 6 shows a timing diagram of an acousto-optic imaging system in accordance with an alternative preferred embodiment of the invention for imaging two slices of objects such as that shown in Fig. 5.

### DETAILED DESCRIPTION OF PREFERRED EMBODIMENTS

20 Fig. 1 shows an acousto-optical cell 10 of a type especially suitable for use in conjunction with the present invention. While a number of different types of such devices are available, and while many of them can be useful in the present invention, the preferred embodiments of the present invention as described with respect to a liquid crystal acousto-optical converter whose molecules are naturally horizontally oriented, i.e., perpendicularly to the thickness of the cell.

25 The average orientation of molecules of a liquid crystal material 12 in cell 10 can be changed by applying a vertical electric field to the material between a preferably anti-reflection coated glass window 14 and an acoustically transparent mirror surface 16. As described, for example, in the above referenced paper by Hamidzada et al., such a cell can be provided in bistable form, i.e., the molecules are either vertically oriented or are horizontally oriented  
30 depending on their energy state. In the preferred embodiment of the invention such bistable devices are used, with the rest state orientation being in the horizontal direction and a biased state being in the vertical direction. Acoustic waves which impinge the cell, if they have a high

enough energy, will flip the molecular axis to the horizontal direction, which has a higher energy in the presence of the vertical electric field. The strength of the electric field will control the energy difference between the vertical and horizontal orientations of the molecules and thus will control the amount of acoustic energy required to flip the molecules from vertical to horizontal orientation.

Figs. 2A and 2B illustrate a methodology and an acousto-optic converter 18, useful in the present invention, for determining the direction of the molecules in the liquid crystal converter. In Fig. 2A an electric field as aforesaid is applied to cell 10 of Fig. 1 and no acoustic energy is applied to the cell. Light from a LED or other source 22 is expanded and collimated by a lens system shown schematically as a lens 24. The collimated light impinges a polarizing beamsplitter 26. Beamsplitter 26 passes a light beam 28 having a given polarization toward cell 10 and reflects light with an orthogonal polarization toward an absorber 30 whereat it is absorbed. Alternatively or additionally, the light produced by the LED may be polarized or a polarizer 21 may be placed between the source and beamsplitter 26.

Since, in the absence of acoustic energy the molecules are directed perpendicularly to the polarization of the light in beam 28, the polarization of the light is unaffected by the presence of the cell and is reflected by mirror surface 16 with the same polarization as the light in beam 28. This light passes through beamsplitter 26 without reflection.

Thus, a camera, such as a CCD camera 32, placed to receive light reflected by beamsplitter 26, and focused by a lens system indicated by a lens 34, will not receive any light. Optionally, a polarizer 36, oriented to block any stray light having the polarization of the light incident on or reflected by the unexcited cell, is placed between beamsplitter 26 and camera 32.

Fig. 2B shows the effect of acoustic energy 37 which is incident on cell 12 from below, through mirror 16. Those portions of the cell which are subjected to acoustic energy greater than the threshold of the converter will have their molecules directed in one of the horizontal directions of the converter. One of the directions is generally preferred based on the manufacturing process used to produce the converter. If the light in beam 28 has its polarity at an angle, preferably a 90 degree angle, to this horizontal direction, the polarization of the light will be changed from linear to elliptical, with a component of polarization perpendicular to that of the light in beam 28. This component of light will then be reflected from beamsplitter 26 and will be focused by lens 34 on camera 32. To the extent that the incoming acoustic energy is

above the threshold only over a portion of the cell, only the portion of beam 28 impinging on the cell will be affected and a pattern will be imaged by camera 32.

Fig. 3 is a schematic illustration of an acousto-optic imaging system 40 in accordance with a preferred embodiment of the present invention useful for imaging an object 42, such as an internal body organ. Imaging system 40 preferably incorporates an acousto-optic converter 18 as described with respect to Figs. 2A and 2B, including cell 10, light source 22, lens system 24, optional polarizer 21, beamsplitter 26, absorber 30, camera 32, lens system 34 and optional polarizer 36. Mirrored side 16 of cell 10 faces object 42 to receive acoustic energy therefrom. Preferably, said acoustic energy is focused by one or more acoustic lenses 44 having variable acoustic focusing power and/or variable spacing such that variable distances to the object may be accommodated by imaging system 40. Such focusing systems are well known in the art. Examples of such focusing systems are described, for example, in the previously referenced US patents 4,338,821 and 4,393,712 although other focusing systems or a fixed focus system may be employed. Preferably, the spaces between acoustic elements (i.e., the two acoustic lenses, the object being viewed and cell 10) are filled with an acoustically transmitting material and preferably serve to match the impedance of the various elements to reduce internal acoustic reflections.

A source of acoustic energy 46 illuminates the object, preferably, with pulsed energy. At interfaces between the object and its surroundings acoustic energy is reflected. A portion of the reflected energy is then focused by lenses 44 onto cell 10.

As the reflected focused energy reaches a threshold set by the bias of the cell, the direction of the molecules, at portions of the cell which are illuminated, is switched and light from source 22 is passed to camera 32 from those portions. If the acoustic illumination is pulsed, then the threshold will be reached first for reflections from portions of the object closer to the imaging system and later for object further from the system. After a short period, the light from source 22 is extinguished such that no further light reaches camera 32. The acoustic energy is turned off at a time consistent with the last acoustic energy from the pulse from any point in the object reaching the converter after the extinguishing of the light.

Camera 32, in its preferred form of a CCD camera, integrates the light which it receives, such that the brightness of an image produced by the camera is proportional to the time between the receipt of the energy by the cell and the extinction of source 22. Thus the optical image produced by the camera from portions of the object which are closer is brighter than for areas

which are far away, after correcting for variations in amplitude of the reflected waves. This is illustrated in a somewhat idealized timing diagram shown in Fig. 4 in which the uppermost curve represents the light from source 22, the second curve represents the acoustic illumination generated by source 46, the third curve represents reflected energy as received from a nearby portion of the object at a first position on cell 10 and the lowermost curve represents reflected energy as received from a portion of the of the object which is further away at a second position on cell 10. The portion of the two lowermost curves which contribute light to the brightness of the image are shown as shading in the curves.

If the velocity within the medium surrounding the object is  $v$ , and the time difference between receipt of the two reflected acoustic waves is  $\Delta t$ , then the distance between the two areas on the object is equal to  $\Delta t * v / 2$ . Since with proper calibration of the system,  $\Delta t$  can be determined from the difference in brightness, an image acquired by the CCD camera from a single acoustic pulse contains all the information necessary for determining the distance of all portions of the object which can be viewed by the imaging system.

In order to calibrate the system, the object is first illuminated by a pulse of acoustic energy while source 22 is extinguished. The source is then turned on for a given time  $t_3$ . For each pixel of the image which is acquired under these circumstances, the brightness divided by  $t_3$  corresponds to a calibration factor which translates brightness into time. It should be noted that since the brightness of the image is not dependent on the magnitude of the reflection (so long as it is above the threshold) the calibration factor should be constant or nearly constant over the entire image.

The brightness values of the image pixels (of the image containing distance information) are divided by the calibration factors for the respective pixels. The brightness of the resulting image is proportional to the distance of the portion of the object corresponding to the pixel from a reference plane toward the imaging system. The reference plane is the plane for which reflected acoustic energy reaches cell 10 just as light source 22 is extinguished.

After acquisition of an image, the cell is reset by applying an electric field to the cell which is strong enough to flip all the molecules to the vertical position. Alternatively, if images are acquired at long intervals, a second image may be taken after the cell has reached a new equilibrium condition, with all the molecules being vertical. In the preferred embodiment described above, the cell is electrified during the entire procedure.

In the above preferred embodiment of the invention, the optical light produced by source is such that only the surface of the object (and its position relative to the reference) is imaged. In a second preferred embodiment of the invention internal structure of an object can be determined.

5 One example of such an object 48 is shown in Fig. 5. This object which is situated in a surrounding having a first impedance has an outer shell having a second impedance and an inner core having a third impedance. As the illuminating wave impinges on the interfaces between the various materials, acoustic energy is reflected towards the imaging system. However, for the timing described above, the wave reflected by the outer surface of the object  
10 will flip the molecules and they will not be sensitive to the reflections from the core. One method of resolving this difficulty is to image the object with varying thresholds on cell 10. If the impedance mismatch between the core and the outer shell is high enough (but not too high), reflections from the outer surface would not trigger the cell while reflections from the inner surface would trigger the cell. This would allow for imaging of the interface between the outer  
15 shell and the core. However, if the impedance differences are not very large, it would not be effective to image the inner material.

In a further preferred embodiment of the invention, the electric field is varied such that the system images the object on a slice by slice basis, wherein distances can be determined within the slices.

20 In Fig. 6 shows a timing diagram for imaging a slice 50. The uppermost curve of Fig. 6 corresponds to the vertical electric field applied to cell 10, the second curve corresponds to the illuminating light pulse generated by source 22, the third curve corresponds to the acoustic illumination, the fourth, fifth and sixth correspond to two reflections from positions 52, 56 and 54 on object 48, respectively. The lowermost curve shows the directions of the molecules in cell  
25 10 corresponding to the images of points 52 (and 54 which image at the same place) and 56 where the higher level of the curve corresponds to vertical alignment and the lower level corresponds to horizontal alignment. In the uppermost curve, the upper level corresponds to a field which sets a threshold so high that the acoustic energy cannot flip the molecules and which quickly flips any horizontal molecules to a vertical orientation. The lower level corresponds to  
30 a level at which acoustic energy can flip the molecules from vertical to horizontal orientation.

In Fig. 6 the electric field is first applied at a high level which switches the molecular polarization to the vertical direction and gives a very high acoustic switching threshold. Thus,

the acoustic pulse which is reflected from point 52 and also from a point 58 on object 48 are not sufficient to switch the direction. On the other hand, acoustic pulses which arrive later, as from points 54 and 56 do switch the molecules and cause light from source 22 to be reflected toward camera 32. the relative distances between these points is found in the same way as for the image  
5 obtained by the timing diagram of Fig. 4.

Slices, preferably partially overlapping slices, are acquired sequentially to produce a three dimensional image of the object.

It should be noted that the ability to discriminate interfaces in the direction of the acoustic beam will be limited by the time duration of the acoustic pulse. Thus, if two objects are  
10 closer together than the time it takes the pulse to travel between them, they cannot be distinguished at all and the nearer interface will completely mask the further one. To reduce the effect of this problem, in a preferred embodiment of the invention, a series of overlapping slices are acquired. Preferably, the threshold level should be set high enough such that the cell is not switched by multiple reflections within the object.

The above imaging schemes allow for the acquisition of either the entire surface of the  
15 object facing the imaging system with a single pulsed acoustic illumination or for the acquisition of a single slice within an object for a single pulse of acoustic illumination. In a further preferred embodiment of the invention a plurality of spaced slices can be acquired for a single acoustic pulse. In this embodiment of the invention, camera 32 is a color CCD camera and source 22 comprises a plurality of sources of colors corresponding to the sensitivity of the  
20 three channels of the CCD camera, for example, RGB. This method increases the efficiency of the system by a factor of 3 and also reduces the time necessary for acquiring an entire object by the same factor

A first slice is acquired utilizing the red (R) light source and the red channel of the CCD.  
25 The system is reset by raising the electric field to the higher level and a second slice is acquired, using the same acoustic pulse and the green (G) light source and channel. Again the system is reset and a third slice is acquired using the blue (B) light source and channel. A second pulse (and if necessary third and subsequent pulses) are utilized to acquire spaced slices between the slices acquired utilizing the first acoustic pulse.

In a practical example of the use of the invention, consider an image of an object in the  
30 human body. The velocity of sound in the body is of the order of  $v=1500$  m/sec. A typical LC relaxation time,  $\tau$  is about 10 microseconds. In examining an object with a thickness of 10 cm,

in a slice-wise fashion using slices 5 mm thick, 20 slices are required. Note that the resolution of the system is better than the thickness of the slices.

To image slices of this thickness, the acoustic pulse width should be the thickness divided by the velocity or 3.3 microseconds long. Using the RGB acquisition sequence described above, we can acquire three slices per acoustic pulse. Due to the finite relaxation time of the LC plate, the must be separated by a distance of at least  $v\tau$  or 15 mm, that is every fifth slice can be imaged utilizing the same acoustic pulse. However, it is generally desirable to space the pulses by a somewhat greater distance, namely, by, for example, imaging every eighth slice. Thus the first acoustic pulse would image the first, eighth and 15th slices, the second acoustic pulse the second, ninth and 16th slices, etc. Thus, seven acoustic pulses (and seven triple slice acquisitions) would be necessary to image the entire object. If an imager to object distance of 10 cm is assumed, the last reflection from an acoustic pulse will travel 30 cm before it is received by the imager which will require that the pulses be at least  $.3/v$  seconds apart or 2 milliseconds apart. Another constraint is the time between fields or frames for the CCD camera. For an ordinary camera, the time between fields is 16.6 milliseconds, so that the maximum acoustic pulse rate using such a system is 60 pulses per second. This would result in the acquisition of an object in about 117 milliseconds (an object acquisition of about 8.5 objects per second). However, if a fast CCD camera is used then a higher frame rate is used, then the acquisition time for the entire object can be reduced, in principle, to 14 milliseconds, for an object acquisition rate of about 70 objects per second. In order to reduce the effect of multiple reflections and of reflections from other bodies in the person, a slower rate would be utilized. However, even a slower rate would allow for real time imaging of moving portions of the body, such as the heart, in real time, with high resolution.

The present invention has been described utilizing an ring source of acoustic energy for illuminating the object being imaged. This is desirable since the object planes which are imaged are parallel to the imaging system. However, the acoustic source may be placed beside the imaging system and may have an axis parallel to or at a small angle to that of the imaging system. Furthermore, while a bistable AOC (LC) is used in the preferred embodiment of the invention, a system which requires continuous acoustic energy to keep the molecular directions flipped may be used, such as an analog LC. Also while the system is described using CCD camera for imaging, other imaging devices such as film or CID devices can be used, in other preferred embodiments of the invention.

It should be understood that the features and methods described herein can be combined in many ways, in accordance with various preferred embodiments of the invention. Furthermore, certain features of the preferred embodiments of the invention may be omitted in accordance with other preferred embodiments of the invention. Other variations of the preferred  
5 embodiments of the present invention within the scope of the claims will occur to persons of skill in the art. It should be understood that the preferred embodiments of the present invention are only illustrative and are not meant to be limiting of the scope of the invention as defined by the claims.



## CLAIMS

1. An acousto-optic imaging system for imaging an object comprising:
  - (a) a source of acoustic energy which illuminates the object;
  - (b) an acousto-optic imaging plate which receives scattered acoustic energy from the  
5 object, said scattered acoustic energy forming an acoustic image at the acousto-optic imaging plate;
  - (c) a source of optical energy which produces optical energy whose characteristics are modified by changes in the acousto-optic imaging plate caused by the received acoustic energy;  
and
  - 10 (d) an optical imager which forms a nonholographic image of modified optical energy,  
wherein the source of acoustic energy is pulsed such that the intensity of the time integral of light detected by the optical imager is an image having an spatially varying intensity wherein the intensity at a point in the optical image is related to the distance from a reference position of a corresponding point in the object.
- 15 2. A system according to claim 1 wherein the source of acoustic energy does not scan the object laterally to the direction of propagation of the illuminating acoustic energy.
3. A system according to claim 1 or claim 2 wherein the optical image is an image of  
20 points on the surface of the object.
4. A system according to claim 3 wherein the source of optical energy is pulsed off only after acoustic energy scattered by the surface to be imaged reaches the acousto-optic image  
plate.
- 25 5. A system according to claim 1 or claim 2 wherein the image is an image of the distance of points in a slice of the object from the reference position.
6. A system according to claim 5 and including a control system which applies a voltage  
30 operative to select either a high acoustic threshold state or a low acoustic threshold state of the acousto optic imaging plate.

7. A system according to claim 5 or claim 6 wherein the high acoustic threshold state is selected for time prior to a time of receipt of acoustic energy scattered from objects at the portion of the slice nearest the acousto-optical imaging plate and the state is changed to the low acoustic threshold state at said time of receipt, such that the time of said change defines the near  
5 distance of the image slice.
8. A system according to any of claims 5-7 wherein the source of optical energy is pulsed off to define the far distance of the image slice.
- 10 9. A system according to claim 4 or claim 8 wherein the reference position is a distance corresponding to a scattered wave which is received at the time the optical energy is pulsed off.
10. A system according to any of the preceding claims wherein the spatially varying intensity is proportional to the distance of a point in the acoustic imager from the reference  
15 position.
11. A system according to any of the preceding claims wherein the intensity values are corrected by a normalization function derived by optically illuminating the acousto-optical plate from the source for a given time period during which the characteristic of the optical energy is  
20 modified by changes in the acousto-optical imaging plate.
12. A system according to any of the preceding claims in which the source of light is linearly polarized and in which the acousto-optical plate does not affect the polarization of the optical energy prior to said change and in which the polarization is converted to elliptical  
25 polarization after said change.
13. A system according to claim 12 wherein the imager responds to the component of the light which has a polarity different from the polarity of light produced by the source.
- 30 14. A system according to any of the preceding claims wherein the optical imager comprises a CCD camera.

15. A system according to any of the preceding claims wherein the acousto-optical imaging plate is a bistable device
16. A system according to any of the preceding claims wherein the imaging plate comprises  
5 a liquid crystal plate.
17. A system according to any of the preceding claims wherein the scattered acoustic energy corresponds to energy reflected from points in the object.
- 10 18. A method of imaging an object, comprising:  
illuminating the object with a pulse of acoustic energy;  
forming an acoustic image, at an acousto-optic imaging plate, of said acoustic energy after scattering thereof by points in a first slice of the object;  
forming an acoustic image, at the acousto-optic imaging plate, of said acoustic energy  
15 after scattering thereof by points in at least one additional slice of the object;  
separately detecting, by an optical imager of light modified by the first and at least one additional acoustic images to form a plurality of optical images from the pulse of acoustic energy,  
wherein the intensity of the optical images have a spatially varying value related to the  
20 distance from a reference position of a corresponding point in the respective slice.
19. A method according to claim 18 and including:  
sequentially illuminating the acousto-optical imaging plate with pulsed light of different colors; and  
25 sequentially detecting said pulsed light of different colors to form said plurality of optical images each representative of one of said slices.
20. A method according to claim 19 wherein the acousto-optical imaging plate can be switched from a first state in which it is not sensitive to said scattered energy to a second state  
30 in which it is modified by said scattered energy and including:

switching the state of the acousto-optical imaging plate from said first state to said second state when scattered energy from each of the respective slices first reaches the imaging plate.

- 5 21. A method according to claim 19 or claim 20 and including:  
extinguishing the source of optical energy when scattered energy from the furthest  
portion of the respective slices reaches the imaging plate.
22. A method according to any of claims 19-21 wherein the optical imager has a plurality of  
10 color channels each sensitive to a different color and wherein the colors of the illuminating light  
corresponds to the respective colors of the color channels.
23. A method according to any of claims 18-23 wherein the optical image intensity of the  
15 formed images corresponds to intensity of the time integral of light detected by the optical  
imager.
24. A method according to any of claims 18-23 wherein the scattered acoustic energy is  
acoustic energy reflected by the object.
- 20 25. A method according to claim 24 wherein the characteristic of the electrical energy which  
is modified is the polarization thereof.

1/5

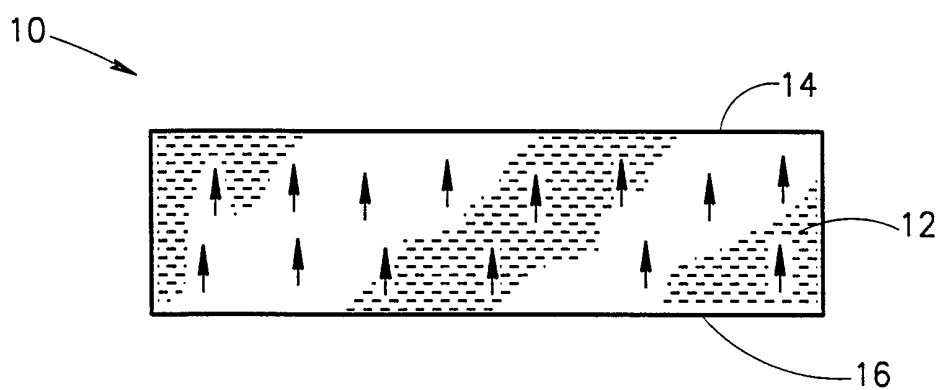

FIG. 1

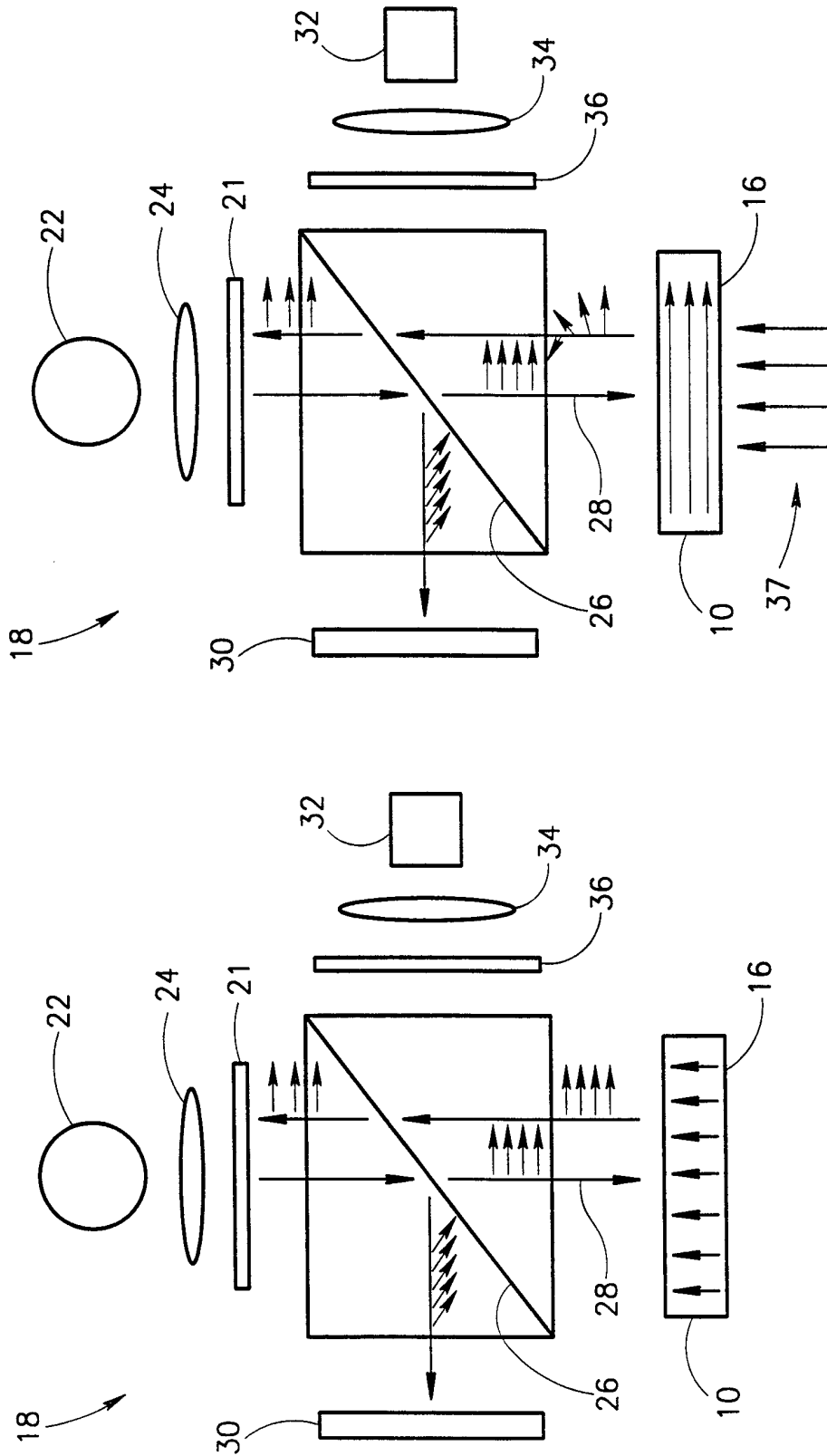

FIG. 2A

FIG. 2B

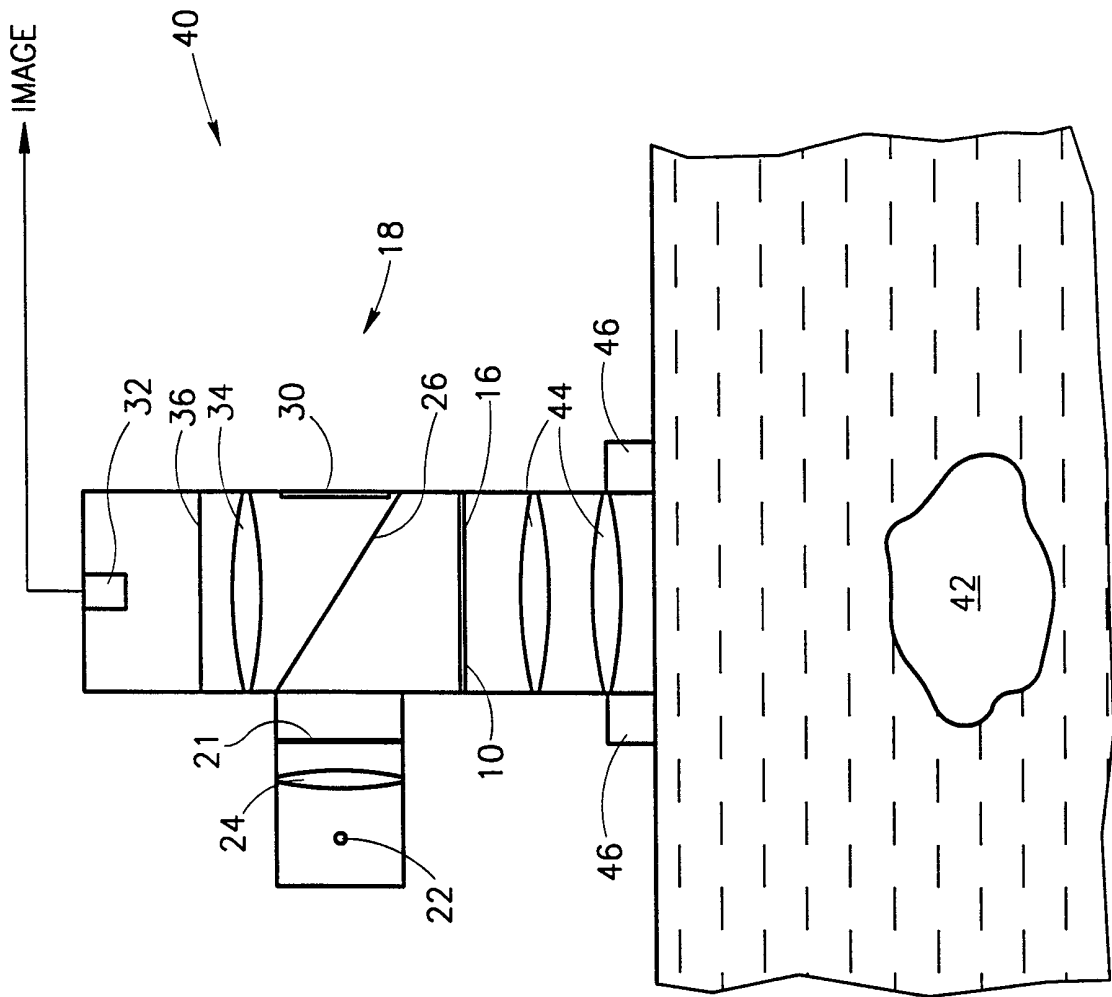

FIG.3

4/5

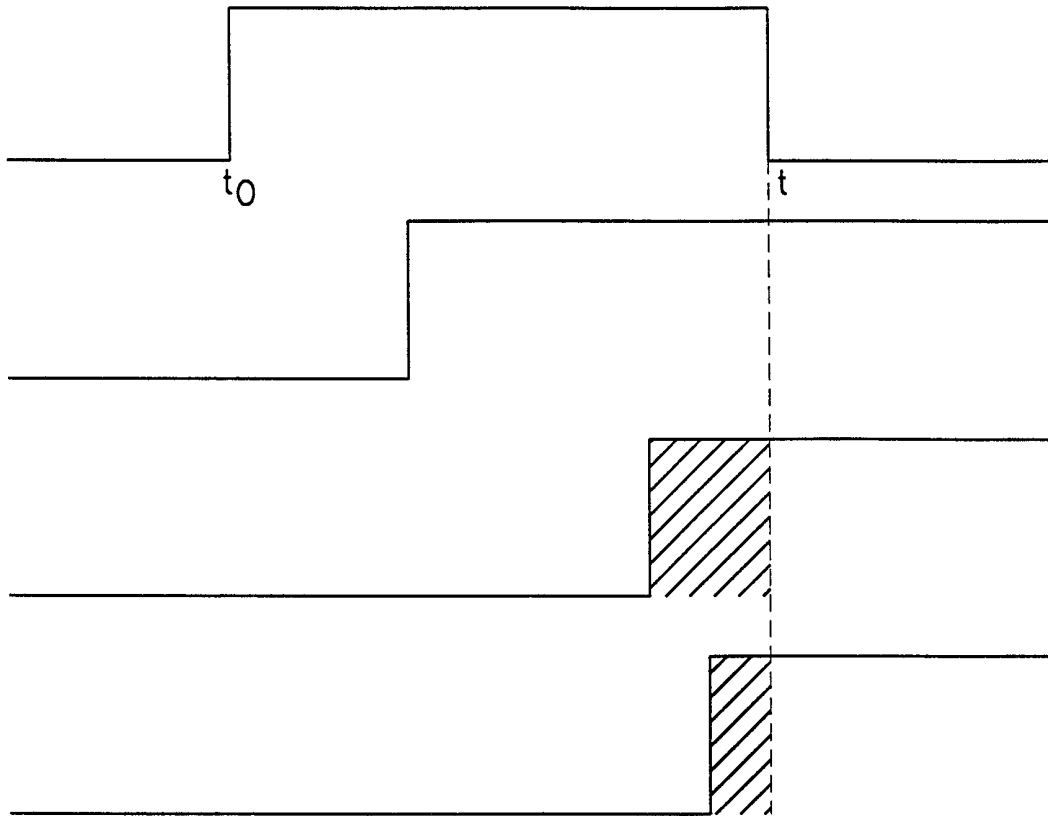

FIG.4

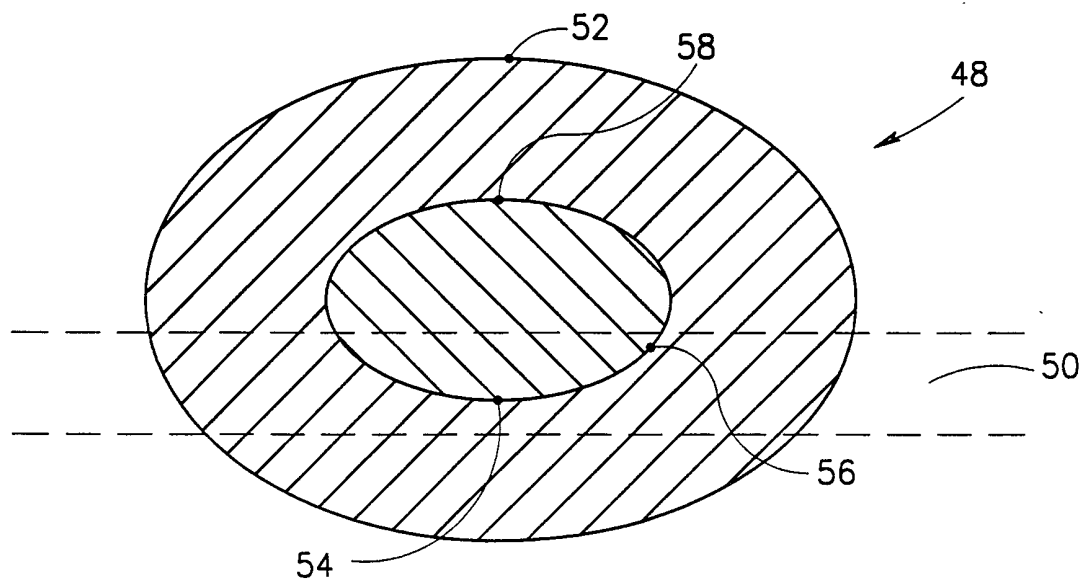

FIG.5



5/5

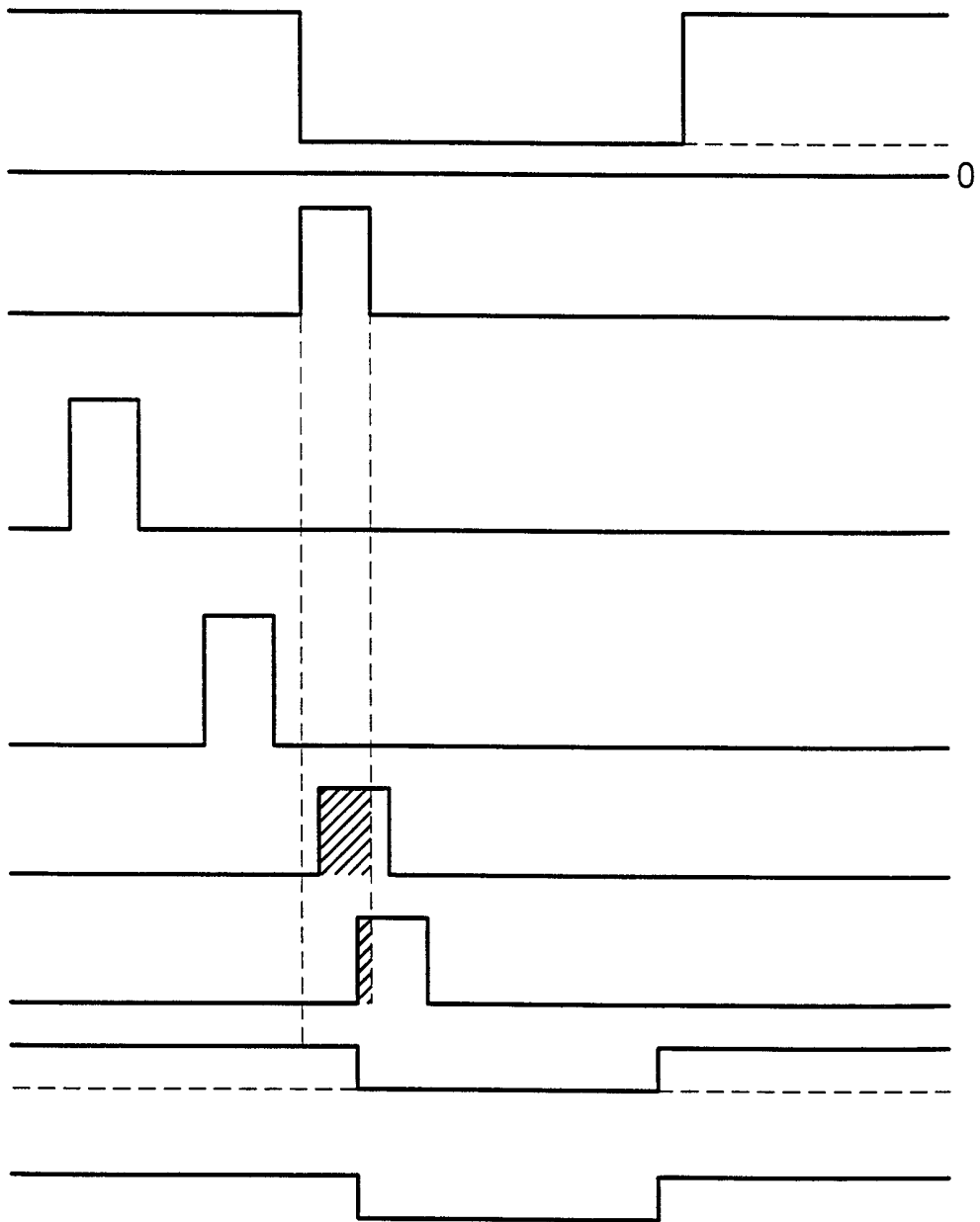

FIG.6

# INTERNATIONAL SEARCH REPORT

International Application No

PCT/IL 97/00313

**A. CLASSIFICATION OF SUBJECT MATTER**  
IPC 6 G01H9/00

According to International Patent Classification (IPC) or to both national classification and IPC

**B. FIELDS SEARCHED**

Minimum documentation searched (classification system followed by classification symbols)  
IPC 6 G01H G01S G01B

Documentation searched other than minimum documentation to the extent that such documents are included in the fields searched

Electronic data base consulted during the international search (name of data base and, where practical, search terms used)

**C. DOCUMENTS CONSIDERED TO BE RELEVANT**

Category <sup>o</sup>	Citation of document, with indication, where appropriate, of the relevant passages	Relevant to claim No.
Y	EP 0 089 841 A (RAJ TECHNOLOGY PARTNERSHIP) 28 September 1983  see abstract  ---	1, 2, 5, 6, 10, 12, 16-18, 24
Y	US 3 831 434 A (GREGUSS P) 27 August 1974  see abstract; claims 1, 17 see column 6, line 36 - line 48  ---	1, 2, 5, 6, 10, 12, 16-18, 24
Y	WO 97 01111 A (3DV SYSTEMS LTD ;YAHAV GIORA (IL); IDAN GAVRIEL I (IL)) 9 January 1997 cited in the application see abstract; claims 1, 10, 11, 14-16, 32, 34 see page 1, line 30 - page 2, line 7  ---	1, 2, 5, 6, 10, 12, 16-18, 24
	-/--	

Further documents are listed in the continuation of box C.

Patent family members are listed in annex.

<sup>o</sup> Special categories of cited documents:

- "A" document defining the general state of the art which is not considered to be of particular relevance
- "E" earlier document but published on or after the international filing date
- "L" document which may throw doubts on priority claim(s) or which is cited to establish the publication date of another citation or other special reason (as specified)
- "O" document referring to an oral disclosure, use, exhibition or other means
- "P" document published prior to the international filing date but later than the priority date claimed

- "T" later document published after the international filing date or priority date and not in conflict with the application but cited to understand the principle or theory underlying the invention
- "X" document of particular relevance; the claimed invention cannot be considered novel or cannot be considered to involve an inventive step when the document is taken alone
- "Y" document of particular relevance; the claimed invention cannot be considered to involve an inventive step when the document is combined with one or more other such documents, such combination being obvious to a person skilled in the art.
- "&" document member of the same patent family

Date of the actual completion of the international search

12 June 1998

Date of mailing of the international search report

19/06/1998

Name and mailing address of the ISA

European Patent Office, P.B. 5818 Patentlaan 2  
NL - 2280 HV Rijswijk  
Tel. (+31-70) 340-2040. Tx. 31 651 epo.nl.  
Fax: (+31-70) 340-3016

Authorized officer

Haasbroek, J

# INTERNATIONAL SEARCH REPORT

International Application No

PCT/IL 97/00313

**C.(Continuation) DOCUMENTS CONSIDERED TO BE RELEVANT**

Category <sup>2</sup>	Citation of document, with indication, where appropriate, of the relevant passages	Relevant to claim No.
A	DE 27 46 222 A (WILHELMS WALTER) 19 April 1979 see page 5, line 18 - line 32; claim 1 -----	1,2,5

# INTERNATIONAL SEARCH REPORT

Information on patent family members

International Application No

PCT/IL 97/00313

Patent document cited in search report	Publication date	Patent family member(s)	Publication date
EP 0089841    A	28-09-1983	US 4492107 A	08-01-1985
		AU 560247 B	02-04-1987
		AU 1264383 A	29-09-1983
		CA 1204496 A	13-05-1986
		JP 58213220 A	12-12-1983
US 3831434    A	27-08-1974	CA 1002172 A	21-12-1976
		DE 2313738 A	27-09-1973
		FR 2177410 A	02-11-1973
		GB 1433623 A	28-04-1976
		JP 49008261 A	24-01-1974
WO 9701111    A	09-01-1997	AU 6135996 A	22-01-1997
		AU 6136096 A	22-01-1997
		AU 6136496 A	22-01-1997
		EP 0835460 A	15-04-1998
		WO 9701112 A	09-01-1997
		WO 9701113 A	09-01-1997
DE 2746222    A	19-04-1979	DE 3026869 A	11-02-1982