



US 20060207127A1

(19) **United States**

(12) **Patent Application Publication**  
**McGrath**

(10) **Pub. No.: US 2006/0207127 A1**

(43) **Pub. Date: Sep. 21, 2006**

(54) **INTERCHANGEABLE FOOTWEAR**

**Publication Classification**

(76) **Inventor: Colleen McGrath**, Long Beach, NY  
(US)

(51) **Int. Cl.**  
*A43B 3/12* (2006.01)  
*A43B 3/24* (2006.01)  
(52) **U.S. Cl.** ..... **36/101; 36/11.5**

Correspondence Address:  
**DAVIDSON, DAVIDSON & KAPPEL, LLC**  
**485 SEVENTH AVENUE, 14TH FLOOR**  
**NEW YORK, NY 10018 (US)**

(57) **ABSTRACT**

The invention described herein relates to the filed of footwear. In particular the present invention provides for interchangeable footwear, wherein the appearance of the footwear is readily interchangeable to suit the style of the intended wearer, the interchangeable components being the toe straps and ankle straps that secure the footwear to an individual's feet.

(21) **Appl. No.: 11/081,291**  
(22) **Filed: Mar. 16, 2005**

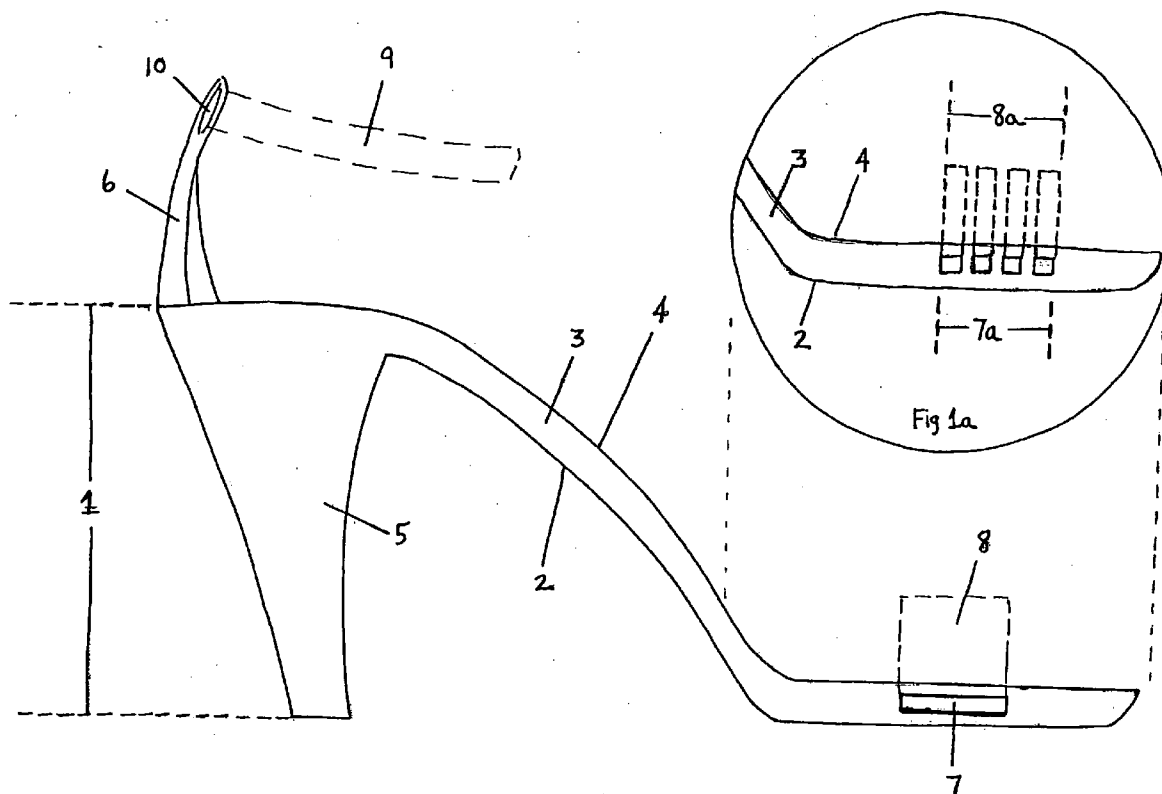

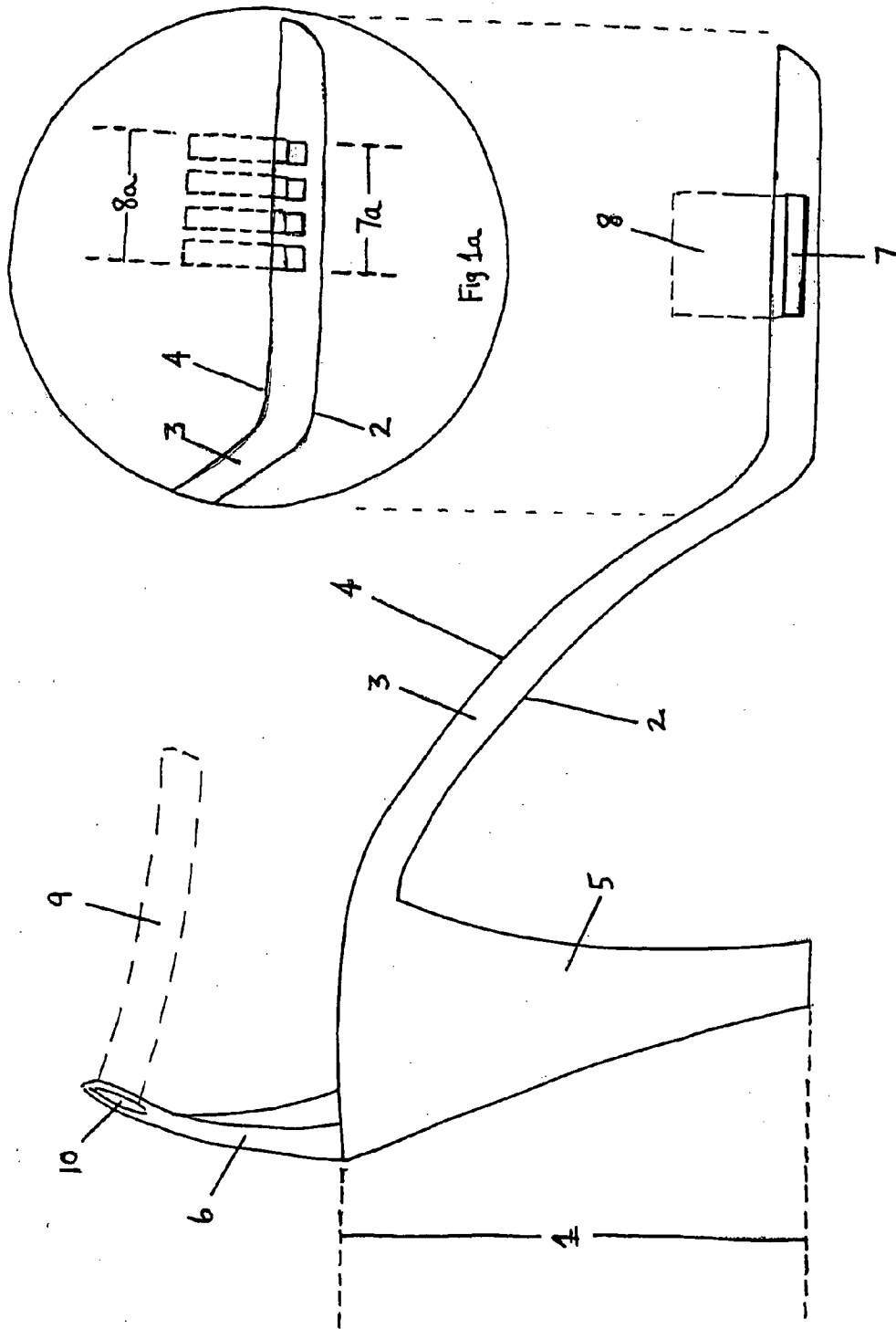

Fig. 1

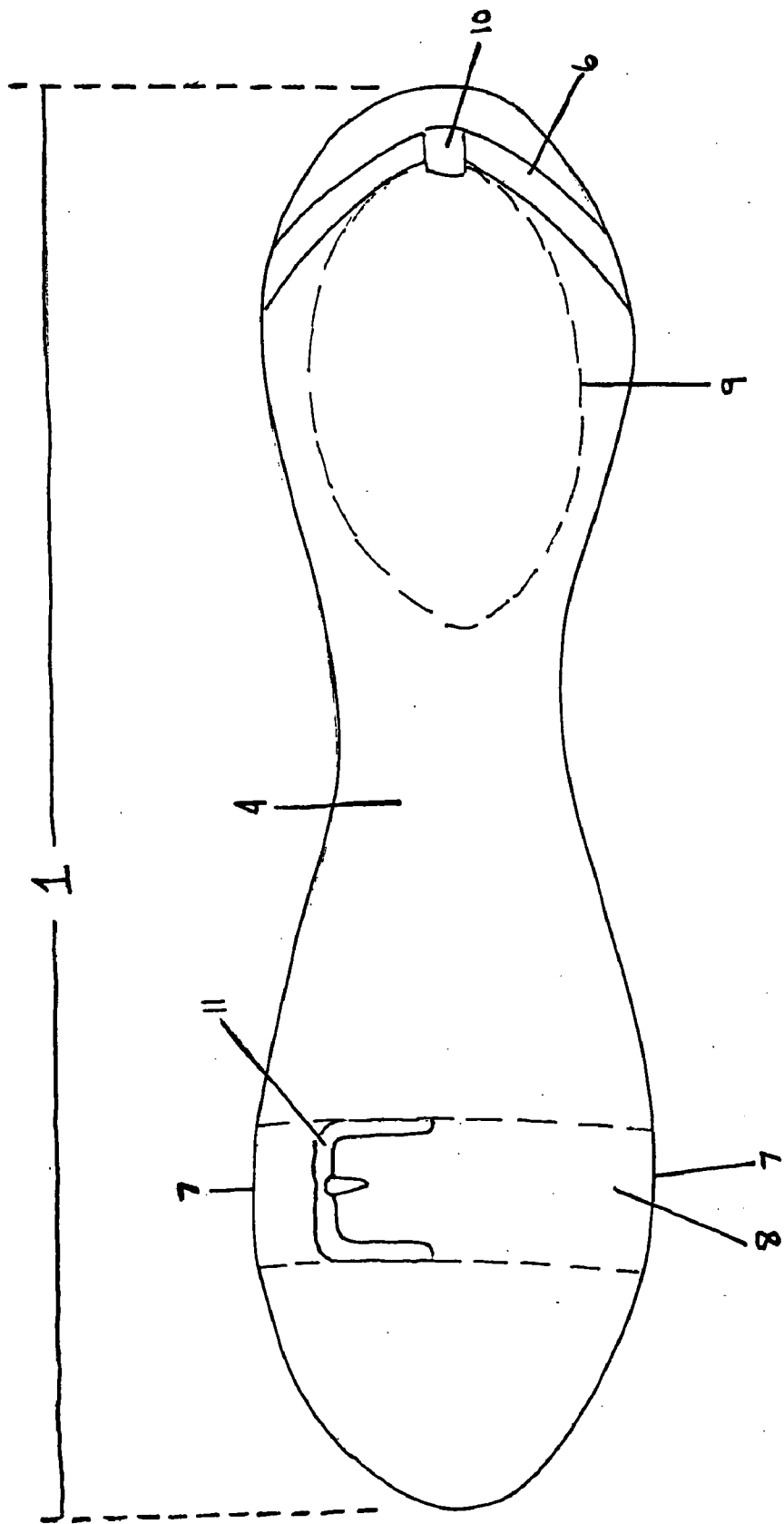

Fig. 2

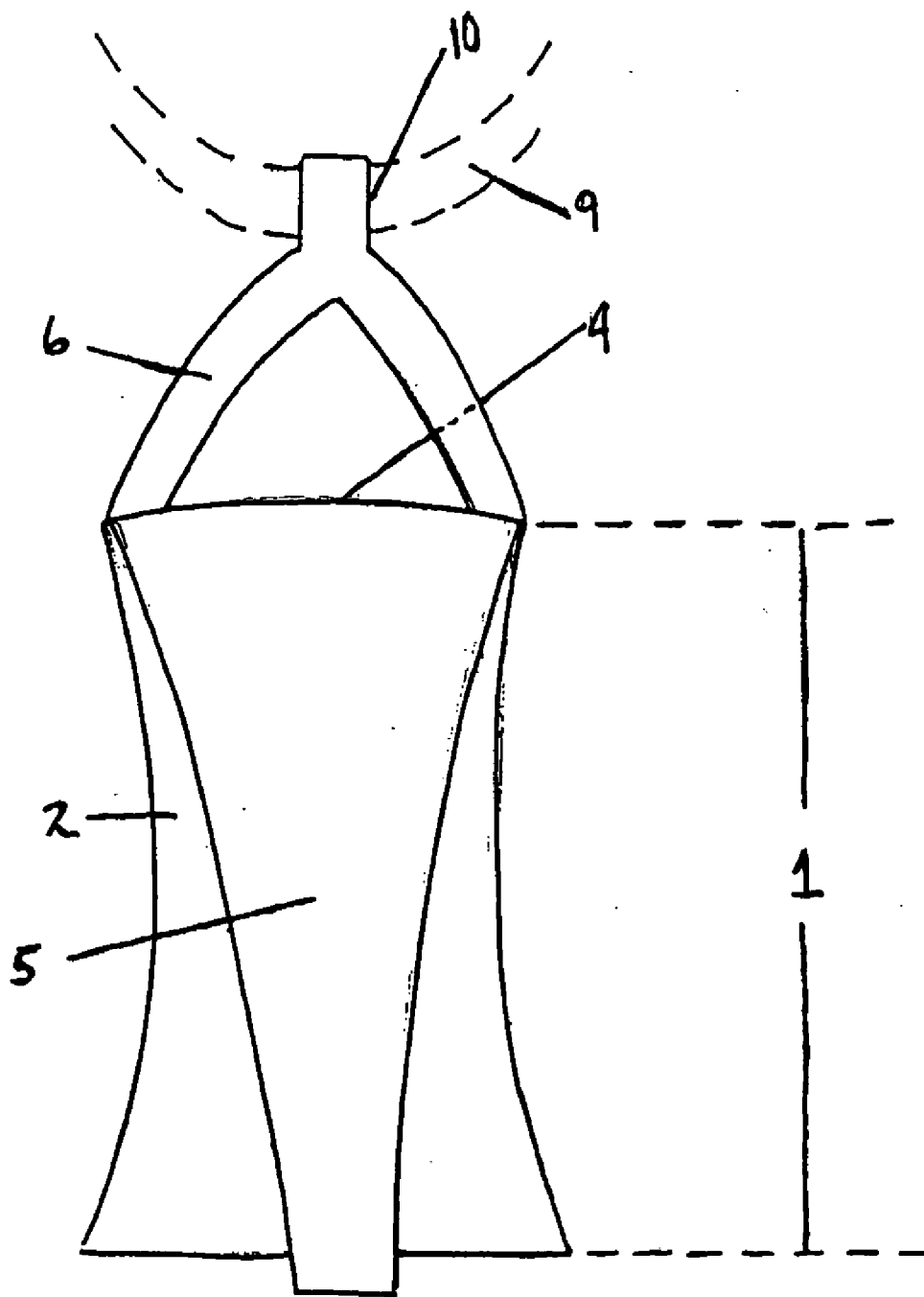

Fig. 3

## INTERCHANGEABLE FOOTWEAR

### BACKGROUND OF THE INVENTION

[0001] The present invention relates to the field of interchangeable footwear, wherein the appearance of the footwear is readily interchangeable to suit the style of the intended wearer. Specifically the invention relates to footwear having an interchangeable ankle strap and an interchangeable toe strap such that various decorative straps can be utilized with a single article of footwear. The interchangeable footwear allows for an individual to dress for the occasion without the need for having an extensive personal inventory of shoes that are both costly and space consuming.

[0002] Several different types of interchangeable footwear have been developed over the years starting back as early as the 1940's. These styles range in form from shoes that provide for adjustment of the shoe upper that suit the individual anatomical differences of an individual's feet to shoes that provide a means for interchanging the entire shoe upper including the insole.

[0003] Specifically, U.S. Pat. No. 2,507,120 (Shapiro) describes a shoe wherein the shoe upper is detachable from the sole via fastener elements to provide a shoe that is convertible into a house shoe, a shoe for street wear or a sandal, the shoe being adjustable to fit variations in a person's anatomical foot structure. U.S. Pat. No. 2,552,943 (Danielius) describes shoes having detachable uppers, whereby the upper is readily detachable from the shoe via co-operating detachable engageable elements, e.g., loop fastening element. U.S. Pat. No. 2,761,224 (Gardiner) describes a shoe with a detachable upper, wherein the upper is attachable to the sole via insertion of a "T" member into a traverse tack or channel positioned around the periphery of the insole, outsole or platform of the shoe. U.S. Pat. No. 2,809,449 (Smith) describes a shoe with a detachable upper, whereby the upper is attached to the sole of a shoe via a slide fastener element that locks into a locking means. U.S. Pat. No. 3,016,630 (Twiggs Jr.) describes a shoe whereby the upper is detachable from the sole via various means such as snaps, sockets and key slots.

[0004] Other patents include: U.S. Pat. No. 2,583,826 (Fischer) which describes shoes with interchangeable panels, whereby the interchangeable panels can be attached to a plurality of spaced apart straps that are permanently affixed to the shoe. U.S. Pat. No. 2,887,795 (Taicher) describes a shoe with an readily removable, ornamental, interchangeable vamp area, whereby the interchangeable vamp is fixedly attached to the shoe via headed studs. U.S. Pat. No. 3,032,896 (Weaver) describes a convertible shoe, whereby a vamp cover can be attached to a vamp to provide various colors and shades to the shoe. U.S. Pat. No. 3,204,346 (Lockard et al.) describes a shoe with an interchangeable upper, whereby the upper is attached to trackways and/or slots of the sole of the shoe via buttons or knobs attached to the upper. U.S. Pat. No. 4,193,214 (Wang) describes a changeable sandal, whereby interchangeable vamps are inserted into the sole of the sandal via L-shaped angles and U.S. Pat. No. 4,439,935 (Kelly) describes convertible footwear, whereby an interchangeable shoe upper composed of a vamp and an insole as a unit-construction can be attached to a shoe base.

[0005] Although many of these patents describe various forms of interchangeable footwear, all of these patents

require relatively complicated means for manufacture and interchanging of the various components. For example, several of these patents require multiple attachment means utilizing numerous parts. It would therefore be advantageous to provide footwear that allows for a more simplistic attachment of the interchangeable components to provide for more economical, yet esthetically appealing footwear.

### SUMMARY OF THE INVENTION

[0006] It is an object of the present invention to provide economical, yet esthetically appealing footwear.

[0007] It is another object of the present invention to provide footwear with interchangeable straps that are readily attached thereto and removable therefrom allowing the wearer to readily change the color, fabric, and design of the footwear as desired.

[0008] The above objects and others are accomplished by providing footwear having a base unit comprising a sole and an opening in the front portion of the base unit that allows for the attachment of interchangeable support straps that provide a means of securing the footwear on an individual's feet.

[0009] In other embodiments of the present invention, the footwear contains an opening on the front portion of the base unit whereby toe straps can be attached therethrough to provide a means of keeping the footwear on an individual's feet. In certain embodiments the opening contains a strap adjustment to allow for forward and backward movement of the strap along the base unit so that an individual may adjust the strap to fit the individual's anatomical foot structure.

[0010] In certain embodiments of the invention, the footwear comprises a base unit having an outsole, midsole, insole and a heel. In other preferred embodiments the base unit also comprises a heel support. The heel support may contain an ankle strap slot, whereby another interchangeable strap can be attached to provide an additional means for securing the footwear on an individual's feet.

### BRIEF DESCRIPTION OF THE DRAWINGS

[0011] The following drawings are illustrative of embodiments of the invention and are not meant to limit the scope of the invention as encompassed by the claims.

[0012] **FIG. 1** is a side view of a base unit of an interchangeable footwear.

[0013] **FIG. 2** is a top view of the interchangeable footwear of **FIG. 1**.

[0014] **FIG. 3** is a back view of the interchangeable footwear of **FIG. 1**.

### DETAILED DESCRIPTION OF THE PREFERRED EMBODIMENTS

[0015] The footwear disclosed herein can be used for various purposes such as, but not limited to indoor use as, e.g., slippers, or for outdoor use, e.g., sandals, pumps, flats, or comfort, casual and formal wear. In one preferred embodiment, the footwear described herein preferably will comprise a base unit **1** having an outsole **2**, a midsole **3** and an insole **4** with an opening **7** in the front portion of the base unit **1** for attachment of a toe strap **8** therethrough, the

midsole 3 being fixedly attached to the top of the outsole 2 and the insole 4 being fixedly attached to the top portion of the midsole 3. In certain embodiments, the outsole 2, midsole 3 and insole 4 can be a single solid unit made up of the same material. In other embodiments, the outsole 2, midsole 3 and insole 4 can be made up of individual components of the same or different material.

[0016] In certain embodiments of the invention, the front portion of the base unit 1 preferably has a single opening 7 for attachment of a single toe strap 8. In other preferred embodiments, the base unit 1 contains a plurality of openings 7a for attachment of a plurality of toe straps 8a. The opening(s) 7 (7a) being made up of various shapes and sizes such as, but not limited to, circular, elliptical, oval, rectangular, square, and triangular shapes. The opening(s) 7 (7a) of the present invention preferably has a length in the range from about 1/16 inch to about 2 inches, and more preferably from about 1/2 inch to about 1 inch. The opening(s) 7 (7a) preferably has a width in the range from about 0.5 mm to about 10 mm, more preferably from about 1 mm to about 5 mm.

[0017] The toe strap(s) 8 (8a) of the present invention is changeably (unfixedly) attached to the base unit 1 via insertion of the toe strap(s) 8 (8a) into one side of the opening(s) 7 (7a) and pulled there through such that one end of the toe strap(s) 8 (8a) is positioned on the left side of the base unit 1 and the opposite end of the toe strap(s) 8 (8a) is positioned on the right side of the base unit. Once in place, the opposite ends of the toe strap(s) 8 (8a) can be fastened together either by use of a fastening device 11 or by directly tying both ends of the toe strap(s) 8 (8a) together, thus providing a means for securing the footwear on the feet of the individual.

[0018] In other preferred embodiments, the footwear may contain a heel 5 fixedly attached to the bottom of the outsole 2. The heel 5 being positioned at the back portion of the base unit 1, and extending downward from the bottom of the outsole 2, the length of the heel 5 preferably ranging from about 1/8 inch to about 6 inches, more preferably from about 1/2 inch to about 4 inches, and most preferably from about 1 inch to about 3 inches.

[0019] In other embodiments of the present invention, the footwear may contain a heel support 6 fixedly attached to the top of the outsole 2, the heel support 6 being positioned at the back portion of the outsole 2, the heel support 6 providing support for an individual's heel. The heel support 6 may be a solid support or a single strap fixedly attached to the top of the insole 4 positioned at the back portion of the insole 4. In other embodiments of the present invention, the footwear may contain a heel support 6 having a plurality of straps that are fixedly attached to the top of the insole 4 in an adjacent manner to one another.

[0020] With any of the above-mentioned embodiments, the heel support 6 may contain a single ankle strap slot 10 attached thereto for changeable attachment of an ankle strap 9. In other embodiments, the heel support 6 may contain a plurality of ankle strap slots 10, the ankle strap slot(s) 10 being fixedly attached to the heel support 6 for changeable attachment of a plurality of ankle straps 9. When the footwear of the present invention contains a heel support 6, the ankle strap slot(s) 10 may be positioned along the inside surface or the outside surface of the heel support 6. In other

embodiments, the ankle strap slot may extend through both the inner and outer surface of the heel support 6.

[0021] When the footwear of the present invention contains a heel support 6 having a single strap, the ankle strap slot(s) 10 may be positioned at the top of the strap. Multiple ankle strap slots 10 can be positioned adjacent to one another along the single strap. The invention also contemplates the use of multiple ankle strap slots 10 when the footwear contains a plurality of straps as well.

[0022] The ankle strap slot(s) 10 of the present invention contain an opening preferably ranging from 1/16 inch to about 1 inch, preferably from about 1/8 inch to about 3/4 of an inch.

[0023] The composition of the heel support 6, the toe strap(s) 8 (8a), the ankle strap(s) 9 as well as any of the other components of the base unit 1 of the present invention may comprise various materials or fabrics suitable for use in footwear. For example, the heel support 6, the toe strap(s) 8 (8a), the ankle strap(s) 9 and any of the other components of the base unit 1 can comprise, but not be limited to, leather, plastic, velcro, rubber, silk, rayon, cotton, denim, polyester, cashmere, twill, corduroy, satin, angora, natural and/or synthetic fur, vinyl, suede, licra, gems, stones, gold, silver, platinum and the like or any combinations thereof.

[0024] It is contemplated that the toe strap(s) 8 (8a) and the ankle strap(s) 9 of the present invention can be various lengths and widths to allow for greater interchangeability and function. The toe strap(s) 8 (8a) and the ankle strap(s) 9 can be from about 1/16 inch in width to about 2 inches in width, preferably from about 1/8 inch to about 1 inch. In certain embodiments, the toe strap(s) 8 (8a) and the ankle straps 9 can be preferably from about 2 inches in length to about 10 inches in length, more preferably from about 4 inches in length to about 8 inches in length.

[0025] The materials, sizes and shapes of the toe strap(s) 8 (8a) and the ankle strap(s) 9 should be amendable for providing numerous designs or fashions, thereby allowing the footwear of the present invention to be multifunctional for many activities and occasions.

[0026] The footwear of the present invention can be secured to an individual's feet by use of a fastener 11 or plurality of fasteners 11. A fastener 11 may be utilized to fasten the end of the toe strap(s) 8 (8a) and/or ankle strap(s) 9 together, thus providing a means for securing the footwear to the feet of an individual. Fastening devices 11 of the present invention may include, but is not limited to, a buckle, velcro, a snap, a button, a headed stud, a pin, a clip, a clamp, a coupling, a hook, a latch, a lock, a bracelet or chain or any combinations of the foregoing. In other embodiments of the invention, the fastening device 11 may be a plurality of the foregoing.

[0027] In certain embodiments of the present invention, the changeably (unfixedly) attached toe strap(s) 8 (8a) and the ankle strap(s) 9 may be fastened by tying the opposite ends of the toe strap(s) 8 (8a) and the opposite ends of the ankle strap(s) 9 together, for example, in a knot or bow. Thus providing a means for keeping the footwear on the feet of the individual wearing the footwear.

[0028] The footwear of the present invention may be packaged in numerous fashions. In certain embodiments, it is contemplated that the base unit 1 is packaged together

with one or a plurality of interchangeable ankle straps 9 and/or toe straps 8a. It is further contemplated that the ankle straps 9 and/or toe strap(s) 8 (8a) can be packaged separately from the base unit 1. It is also contemplated that the base unit 1 will be individually packaged.

[0029] In the preceding specification, the invention has been described with reference to specific exemplary embodiments and examples thereof. It will, however, be evident that various modifications and changes may be made thereto without departing from the broader spirit and scope of the invention as set forth in the claims that follow. The specification and drawings are accordingly to be regarded in an illustrative manner rather than a restrictive sense.

What is claimed is:

- 1. Interchangeable footwear comprising:
  - a base unit having an outsole, a midsole and an insole, wherein a front portion of the base unit has an opening therethrough for attachment of an interchangeable toe strap.
  - 2. The footwear of claim 1, further comprising a toe strap changeably attached to the base unit.
  - 3. The footwear of claim 1, wherein the front portion of the base unit has a plurality of openings for attachment of a plurality of toe straps.
  - 4. The footwear of claim 1, wherein the opening is circular.
  - 5. The footwear of claim 1, wherein the opening is elliptical.
  - 6. The footwear of claim 1, wherein the opening is oval.
  - 7. The footwear of claim 1, wherein the opening is rectangular.
  - 8. The footwear of claim 1, wherein the opening is square.
  - 9. The footwear of claim 1, wherein the opening is triangular.
  - 10. The footwear of claim 1, wherein the opening has a length in the range from about 1/16 inch to about 2 inches and a width in the range from about 0.5 mm to about 10 mm.
  - 11. The footwear of claim 2, further comprising a fastener device for fastening the toe straps to the base unit.
  - 12. The footwear of claim 11, wherein the fastener device is selected from the group consisting of a buckle, velcro, a snap, a button, a headed stud, a pin, a clip, a clamp, a coupling, a hook, a latch, a lock, a bracelet, a chain and combinations of the foregoing.
  - 13. The footwear of claim 2, further comprising a heel fixedly attached to the bottom of the outsole at the back portion of the base unit.
  - 14. The footwear of claim 13, wherein the length of the heel ranges from about 1/8 inch to about 6 inches.
  - 15. The footwear of claim 2, further comprising a heel support fixedly attached to the top of the insole at the back portion of the base unit.
  - 16. The footwear of claim 15, wherein the heel support is a strap.
  - 17. The footwear of claim 15, wherein the heel support is a plurality of heel straps.
  - 18. The footwear of claim 15, wherein the heel support contains an ankle strap slot attached thereto for changeable attachment of an ankle strap.

19. The footwear of claim 15, wherein the heel support contains a plurality of ankle strap slots attached thereto for changeable attachment of a plurality of ankle straps.

20. The footwear of claim 18, further comprising an ankle strap changeably attached to the heel support or heel strap by insertion through the ankle strap slot.

21. The footwear of claim 19, further comprising a plurality of ankle straps changeably attached to the heel support.

22. The footwear of claim 18, wherein the ankle strap slot has an opening ranging from about 1/16 inch to about 2 inches.

23. The footwear of claim 2, wherein the toe strap comprises a material selected from the group consisting of leather, plastic, velcro, rubber, silk, rayon, cotton, denim, polyester, cashmere, twill, corduroy, satin, angora, natural and/or synthetic fur, vinyl, suede, licra, gems, stones, gold, silver, platinum and combinations thereof.

24. The footwear of claim 20, wherein the ankle strap comprises a material selected from the group consisting of leather, plastic, velcro, rubber, silk, rayon, cotton, denim, polyester, cashmere, twill, corduroy, satin, angora, natural and/or synthetic fur, vinyl, suede, licra, gems, stones, gold, silver, platinum and combinations thereof.

25. The footwear of claim 2, wherein the width of the toe strap ranges from about 1/16 inch to about 2 inches and the length from about 2 inches to about 10 inches.

26. The footwear of claim 20, wherein the width of the ankle strap ranges from about 1/16 inch to about 2 inches and the length from about 2 inches to about 10 inches.

27. The footwear of claim 20, further comprising a fastener device for fastening the ankle straps to the heel support.

28. The footwear of claim 27, wherein the fastener device is a buckle, velcro, a snap, a button, a headed stud, a pin, a clip, a clamp, a coupling, a hook, a latch, a lock, a bracelet, a chain and combinations of the foregoing.

- 29. Interchangeable footwear comprising:
  - a base unit having an outsole, a midsole and an insole, wherein a back portion of the base unit has a heel support attached thereto, the heel support having an ankle strap slot that provides for changeable attachment of an ankle strap.

30. The footwear of claim 29, further comprising an opening at the front portion of the base unit that provides for attachment of an interchangeable toe strap.

- 31. Interchangeable footwear comprising:
  - a base unit having an outsole, a midsole and an insole, wherein a front portion of the base unit has an opening therethrough for attachment of an interchangeable toe strap and a back portion of the base unit has a heel support attached thereto, the heel support having an ankle strap slot that provides for changeable attachment of an ankle strap.