



- (51) International Patent Classification:
G02B 21/02 (2006.01)
- (21) International Application Number:
PCT/EP2015/067352
- (22) International Filing Date:
29 July 2015 (29.07.2015)
- (25) Filing Language: English
- (26) Publication Language: English
- (30) Priority Data:
62/056,701 29 September 2014 (29.09.2014) US
- (71) Applicant: ASML NETHERLANDS B.V. [NL/NL]; P.O. Box 324, NL-5500 AH Veldhoven (NL).
- (72) Inventor: RYZHIKOV, Lev; 77 Danbury Road, Wilton, Connecticut 06987 (US).
- (74) Agent: SLENDERS, Peter; P.O. Box 324, NL-5500 AH Veldhoven (NL).
- (81) Designated States (unless otherwise indicated, for every kind of national protection available): AE, AG, AL, AM, AO, AT, AU, AZ, BA, BB, BG, BH, BN, BR, BW, BY, BZ, CA, CH, CL, CN, CO, CR, CU, CZ, DE, DK, DM,

DO, DZ, EC, EE, EG, ES, FI, GB, GD, GE, GH, GM, GT, HN, HR, HU, ID, IL, IN, IR, IS, JP, KE, KG, KN, KP, KR, KZ, LA, LC, LK, LR, LS, LU, LY, MA, MD, ME, MG, MK, MN, MW, MX, MY, MZ, NA, NG, NI, NO, NZ, OM, PA, PE, PG, PH, PL, PT, QA, RO, RS, RU, RW, SA, SC, SD, SE, SG, SK, SL, SM, ST, SV, SY, TH, TJ, TM, TN, TR, TT, TZ, UA, UG, US, UZ, VC, VN, ZA, ZM, ZW.

(84) Designated States (unless otherwise indicated, for every kind of regional protection available): ARIPO (BW, GH, GM, KE, LR, LS, MW, MZ, NA, RW, SD, SL, ST, SZ, TZ, UG, ZM, ZW), Eurasian (AM, AZ, BY, KG, KZ, RU, TJ, TM), European (AL, AT, BE, BG, CH, CY, CZ, DE, DK, EE, ES, FI, FR, GB, GR, HR, HU, IE, IS, IT, LT, LU, LV, MC, MK, MT, NL, NO, PL, PT, RO, RS, SE, SI, SK, SM, TR), OAPI (BF, BJ, CF, CG, CI, CM, GA, GN, GQ, GW, KM, ML, MR, NE, SN, TD, TG).

Published:

- with international search report (Art. 21(3))
- before the expiration of the time limit for amending the claims and to be republished in the event of receipt of amendments (Rule 48.2(h))



WO 2016/050383 A1

(54) Title: HIGH NUMERICAL APERTURE OBJECTIVE LENS SYSTEM

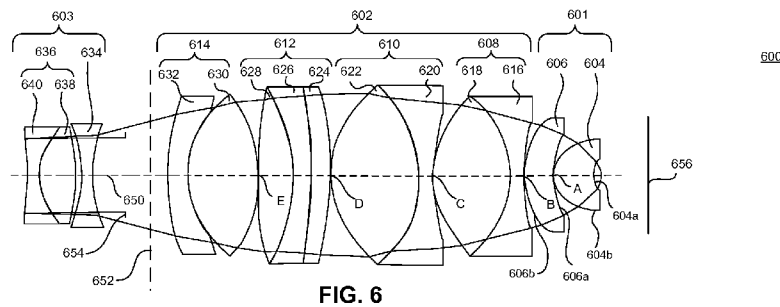

(57) Abstract: An objective lens system having a high numerical aperture, a large working distance, and low optical aberrations over a wide spectral band of wavelengths is disclosed. The objective lens system includes a first lens group, a second lens group, and a third lens group. The first lens group includes first and second positive meniscus lenses that are positioned at a distance from each other along an optical axis of the objective lens system. The distance may be dependent on a focal length of the objective lens system. The second lens group includes first and second meniscus lenses and a bi-convex lens. The third lens group includes a biconvex lens and a doublet lens.

HIGH NUMERICAL APERTURE OBJECTIVE LENS SYSTEM

CROSS-REFERENCE TO RELATED APPLICATIONS

[0001] This application claims the benefit of US application 62/056701, which was
5 filed on September 29, 2014, and which is incorporated herein in its entirety by reference.

FIELD

[0002] The present disclosure relates to various configurations of an objective lens
10 system that may be used in, for example, an inspection system of a lithographic apparatus.

BACKGROUND

[0003] A lithographic apparatus is a machine that applies a desired pattern onto a
target portion of a substrate. Lithographic apparatus can be used, for example, in the
manufacture of integrated circuits (ICs). In that circumstance, a patterning device, which is
15 alternatively referred to as a mask or a reticle, may be used to generate a circuit pattern
corresponding to an individual layer of the IC, and this pattern can be imaged onto a target
portion (*e.g.*, comprising part of, one or several dies) on a substrate (*e.g.*, a silicon wafer) that
has a layer of radiation-sensitive material (resist). In general, a single substrate will contain a
network of adjacent target portions that are successively exposed. Known lithographic
20 apparatus include so-called steppers, in which each target portion is irradiated by exposing an
entire pattern onto the target portion in one go, and so-called scanners, in which each target
portion is irradiated by scanning the pattern through the beam in a given direction (the
“scanning”-direction) while synchronously scanning the substrate parallel or anti parallel to
this direction. It is also possible to transfer the pattern from the patterning device to the
25 substrate by imprinting the pattern onto the substrate.

[0004] In lithographic processes, the patterned substrate and/or the reticle may
be inspected for, *e.g.*, process control and verification. There are various techniques for
performing such inspection, including the use of scanning electron microscopes, and various
specialized inspection systems, which may be used to detect defects on the reticle and/or
30 measure, for example, critical dimension (CD) of the patterns on the substrate, overlay error
between successive layers formed on the substrate. One type of specialized inspection system
is a scatterometer in which a radiation beam is directed onto a target of the pattern on the
surface of the substrate and one or more properties of the scattered or reflected radiation
beam, for example, intensity at a single angle of reflection as a function of wavelength,

intensity at one or more wavelengths as a function of reflected angle, or polarization as a function of reflected angle are measured to obtain a spectrum from which a property of interest of the target may be determined. Determination of the property of interest may be performed by various techniques, such as but not limited to reconstruction of the target structure by iterative approaches (e.g., rigorous coupled wave analysis or finite element methods), library searches, and/or principal component analysis. Two main types of scatterometer are known. Spectroscopic scatterometer that directs a broadband radiation beam onto the substrate and measure the spectrum (intensity as a function of wavelength) of the radiation beam scattered into a particular narrow angular range. Angularly resolved scatterometer that use a monochromatic radiation beam and measure the intensity of the scattered radiation beam as a function of angle.

[0005] Objective lens systems are used in these scatterometers for directing and/or focusing the radiation beam onto the object of inspection (e.g., the reticle, the target of the pattern on the surface of the substrate) and for collecting and/or imaging the scattered or reflected light from the object of inspection. The amount of information obtained from the collected light and/or from the images of the object may depend on the numerical aperture (NA) of the objective lens system and the wavelengths of the radiation beam used in the scatterometers. The higher the NA of the objective lens system and the wider the spectral band of wavelengths used in the scatterometers, the greater is the amount of information that can be obtained from the illuminated object of inspection. However, the highest NA and the maximum spectral bandwidth that can be used in an inspection system are limited by the design and configuration of one or more lenses in the objective lens system.

[0006] There are three types of high NA objective lens systems currently used for scatterometry applications: refractive, reflective, and catadioptric. Certain disadvantages are associated with the use of these current objective lens systems. One of the disadvantages of current high NA refractive objective lens system is that the working distance is relatively small. For example, the working distance is generally less than 0.35 mm for high NA (e.g., 0.9-0.95). Another one of the disadvantages is that the spectral band of wavelengths over which the current high NA refractive objective lens system can operate without compromising optical performance is limited to wavelengths ranging from about 450-700 nm. Use of current refractive objective lens systems outside this spectral band of wavelengths (e.g., below 450 nm wavelength, above 700 nm wavelength, between 410-450 nm wavelengths, between 700-900 nm wavelengths, at deep ultra violet (DUV) wavelengths, at infrared (IR) wavelengths) results in a loss of resolution due to chromatic aberrations (axial

color aberrations). Loss of resolution can lead to reduced accuracy of the scatterometer measurements.

5 [0007] One of the disadvantages of current catadioptric and/or reflective objective lens systems is that they have a large Petzval sum that is far from zero (i.e., they do not have a flat field curvature) and as a result induce field curvature aberration. Pupil aberration is another one of the disadvantages of the current catadioptric and/or reflective objective lens systems due to their large field curvature and pupil size. Further, the current catadioptric and/or reflective objective lens systems suffer from obscuration that reduces the amount of collected light, and hence, the amount of information that can be collected from
10 the object of inspection.

SUMMARY

[0008] Accordingly, there is a need for an improved objective lens system that can be configured to have a high NA without the above mentioned disadvantages.

15 [0009] According to an embodiment, an objective lens system includes a first lens group comprising first and second positive meniscus lenses that may be positioned at a distance from each other along an optical axis of the objective lens system. The distance may be dependent on a focal length of the objective lens system. The objective lens system further includes a second lens group comprising a triplet lens. The triplet lens may comprise a first
20 meniscus lens having a first surface and a second surface, a second meniscus lens having a third surface and a fourth surface, and a bi-convex lens having a fifth surface and a sixth surface. The third surface may be in substantial contact with the second surface and the fifth surface may be in substantial contact with the fourth surface. The objective lens system may further include a third lens group comprising a bi-concave lens and a doublet lens.

25 [0010] In another embodiment, an inspection system may be configured to measure a property of a substrate. The inspection system includes a radiation source that may be configured to produce a radiation beam, an optical system that may be configured to focus the radiation beam on to a surface of the substrate, and a detector that may be configured to detect the radiation beam reflected from the surface of the substrate. The optical system may
30 comprise a first lens group comprising first and second positive meniscus lenses that may be positioned at a distance from each other along an optical axis of the objective lens system. The distance may be dependent on a focal length of the objective lens system. The optical system may further comprise a second lens group comprising a third positive meniscus lens, a negative meniscus lens cemented to the third positive meniscus lens, and a bi-convex lens

cemented to the negative meniscus lens. The optical system may also comprise a third lens group comprising a bi-concave lens and a doublet lens.

[0011] Yet in another embodiment, a lithographic apparatus includes an illumination optical system that may be configured to illuminate a pattern of a patterning device, a projection system that may be configured to project an image of the pattern on to a target portion of a substrate, and an inspection apparatus that may be configured to measure a property of the substrate includes an objective lens system. The objective lens system may comprise a first lens group that may be configured to correct field curvature aberrations and pupil aberrations of the objective lens system. The first lens group may comprise a bi-concave lens and a doublet lens.

[0012] In a further embodiment, an objective lens system includes first and second meniscus lenses positioned at a distance from each other along an optical axis of the objective lens system. The distance may be dependent on a focal length of the objective lens system. The objective lens system may further include third and fourth meniscus lenses in contact with each other, a bi-convex lens in contact with the fourth meniscus lens, a triplet lens, and an aperture stop between the triplet lens and the bi-convex lens.

[0013] Further features and advantages of the invention, as well as the structure and operation of various embodiments of the invention, are described in detail below with reference to the accompanying drawings. It is noted that the invention is not limited to the specific embodiments described herein. Such embodiments are presented herein for illustrative purposes only. Additional embodiments will be apparent to persons skilled in the relevant art(s) based on the teachings contained herein.

BRIEF DESCRIPTION OF THE DRAWINGS/FIGURES

[0014] The accompanying drawings, which are incorporated herein and form part of the specification, illustrate the present invention and, together with the description, further serve to explain the principles of the invention and to enable a person skilled in the relevant art(s) to make and use the invention.

[0015] FIG. 1A is a schematic illustration of a reflective lithographic apparatus according to an embodiment of the invention.

[0016] FIG. 1B is a schematic illustration of a transmissive lithographic apparatus according to an embodiment of the invention.

[0017] FIG. 2 is a more detailed schematic illustration of the reflective lithographic apparatus, according to an embodiment of the invention.

[0018] FIG. 3 is a schematic illustration of a lithographic cell, according to an embodiment of the invention.

[0019] FIGs. 4 and 5 are schematic illustrations of scatterometers, according to various embodiments of the invention.

5 [0020] FIGs. 6 to 9 are schematic illustrations of a cross-sectional view of refractive objective lens systems, according to various embodiments of the invention.

[0021] The features and advantages of the present invention will become more apparent from the detailed description set forth below when taken in conjunction with the drawings, in which like reference characters identify corresponding elements throughout. In
10 the drawings, like reference numbers generally indicate identical, functionally similar, and/or structurally similar elements. The drawing in which an element first appears is indicated by the leftmost digit(s) in the corresponding reference number. Unless otherwise indicated, the drawings provided throughout the disclosure should not be interpreted as to-scale drawings.

15 DETAILED DESCRIPTION

[0022] This specification discloses one or more embodiments that incorporate the features of this invention. The disclosed embodiment(s) merely exemplify the invention. The scope of the invention is not limited to the disclosed embodiment(s). The invention is defined by the claims appended hereto.

20 [0023] The embodiment(s) described, and references in the specification to “one embodiment,” “an embodiment,” “an example embodiment,” *etc.*, indicate that the embodiment(s) described may include a particular feature, structure, or characteristic, but every embodiment may not necessarily include the particular feature, structure, or characteristic. Moreover, such phrases are not necessarily referring to the same embodiment.
25 Further, when a particular feature, structure, or characteristic is described in connection with an embodiment, it is understood that it is within the knowledge of one skilled in the art to effect such feature, structure, or characteristic in connection with other embodiments whether or not explicitly described.

[0024] Before describing such embodiments in more detail, however, it is
30 instructive to present an example environment in which embodiments of the present invention may be implemented.

[0025] *Example Reflective and Transmissive Lithographic Systems*

[0026] FIGs. 1A and 1B are schematic illustrations of a lithographic apparatus 100 and lithographic apparatus 100', respectively, in which embodiments of the present

invention may be implemented. Lithographic apparatus 100 and lithographic apparatus 100' each include the following: an illumination system (illuminator) IL configured to condition a radiation beam B (for example, deep ultra violet or extreme ultra violet radiation); a support structure (for example, a mask table) MT configured to support a patterning device (for example, a mask, a reticle, or a dynamic patterning device) MA and connected to a first positioner PM configured to accurately position the patterning device MA; and, a substrate table (for example, a wafer table) WT configured to hold a substrate (for example, a resist coated wafer) W and connected to a second positioner PW configured to accurately position the substrate W. Lithographic apparatus 100 and 100' also have a projection system PS configured to project a pattern imparted to the radiation beam B by patterning device MA onto a target portion (for example, comprising one or more dies) C of the substrate W. In lithographic apparatus 100, the patterning device MA and the projection system PS are reflective. In lithographic apparatus 100', the patterning device MA and the projection system PS are transmissive.

15 **[0027]** The illumination system IL may include various types of optical components, such as refractive, reflective, catadioptric, magnetic, electromagnetic, electrostatic, or other types of optical components, or any combination thereof, for directing, shaping, or controlling the radiation beam B.

[0028] The support structure MT holds the patterning device MA in a manner that depends on the orientation of the patterning device MA with respect to a reference frame, the design of at least one of the lithographic apparatus 100 and 100', and other conditions, such as whether or not the patterning device MA is held in a vacuum environment. The support structure MT may use mechanical, vacuum, electrostatic, or other clamping techniques to hold the patterning device MA. The support structure MT can be a frame or a table, for example, which can be fixed or movable, as required. By using sensors, the support structure MT can ensure that the patterning device MA is at a desired position, for example, with respect to the projection system PS.

[0029] The term "patterning device" MA should be broadly interpreted as referring to any device that can be used to impart a radiation beam B with a pattern in its cross-section, such as to create a pattern in the target portion C of the substrate W. The pattern imparted to the radiation beam B can correspond to a particular functional layer in a device being created in the target portion C to form an integrated circuit.

[0030] The patterning device MA may be transmissive (as in lithographic apparatus 100' of FIG. 1B) or reflective (as in lithographic apparatus 100 of FIG. 1A).

Examples of patterning devices MA include reticles, masks, programmable mirror arrays, and programmable LCD panels. Masks are well known in lithography, and include mask types such as binary, alternating phase shift, and attenuated phase shift, as well as various hybrid mask types. An example of a programmable mirror array employs a matrix arrangement of small mirrors, each of which can be individually tilted so as to reflect an incoming radiation beam in different directions. The tilted mirrors impart a pattern in the radiation beam B which is reflected by a matrix of small mirrors.

[0031] The term “projection system” PS can encompass any type of projection system, including refractive, reflective, catadioptric, magnetic, electromagnetic and electrostatic optical systems, or any combination thereof, as appropriate for the exposure radiation being used, or for other factors, such as the use of an immersion liquid on the substrate W or the use of a vacuum. A vacuum environment can be used for EUV or electron beam radiation since other gases can absorb too much radiation or electrons. A vacuum environment can therefore be provided to the whole beam path with the aid of a vacuum wall and vacuum pumps.

[0032] Lithographic apparatus 100 and/or lithographic apparatus 100' can be of a type having two (dual stage) or more substrate tables WT (and/or two or more mask tables). In such “multiple stage” machines, the additional substrate tables WT can be used in parallel, or preparatory steps can be carried out on one or more tables while one or more other substrate tables WT are being used for exposure. In some situations, the additional table may not be a substrate table WT.

[0033] Referring to FIGs. 1A and 1B, the illuminator IL receives a radiation beam from a radiation source SO. The source SO and the lithographic apparatus 100, 100' can be separate physical entities, for example, when the source SO is an excimer laser. In such cases, the source SO is not considered to form part of the lithographic apparatus 100 or 100', and the radiation beam B passes from the source SO to the illuminator IL with the aid of a beam delivery system BD (in FIG. 1B) including, for example, suitable directing mirrors and/or a beam expander. In other cases, the source SO can be an integral part of the lithographic apparatus 100, 100'—for example when the source SO is a mercury lamp. The source SO and the illuminator IL, together with the beam delivery system BD, if required, can be referred to as a radiation system.

[0034] The illuminator IL can include an adjuster AD (in FIG. 1B) for adjusting the angular intensity distribution of the radiation beam. Generally, at least the outer

and/or inner radial extent (commonly referred to as “ σ -outer” and “ σ -inner,” respectively) of the intensity distribution in a pupil plane of the illuminator can be adjusted. In addition, the illuminator IL can comprise various other components (in FIG. 1B), such as an integrator IN and a condenser CO. The illuminator IL can be used to condition the radiation beam B to have a desired uniformity and intensity distribution in its cross section.

[0035] Referring to FIG. 1A, the radiation beam B is incident on the patterning device (for example, mask) MA, which is held on the support structure (for example, mask table) MT, and is patterned by the patterning device MA. In lithographic apparatus 100, the radiation beam B is reflected from the patterning device (for example, mask) MA. After being reflected from the patterning device (for example, mask) MA, the radiation beam B passes through the projection system PS, which focuses the radiation beam B onto a target portion C of the substrate W. With the aid of the second positioner PW and position sensor IF2 (for example, an interferometric device, linear encoder, or capacitive sensor), the substrate table WT can be moved accurately (for example, so as to position different target portions C in the path of the radiation beam B). Similarly, the first positioner PM and another position sensor IF1 can be used to accurately position the patterning device (for example, mask) MA with respect to the path of the radiation beam B. Patterning device (for example, mask) MA and substrate W can be aligned using mask alignment marks M1, M2 and substrate alignment marks P1, P2.

[0036] Referring to FIG. 1B, the radiation beam B is incident on the patterning device (for example, mask MA), which is held on the support structure (for example, mask table MT), and is patterned by the patterning device. Having traversed the mask MA, the radiation beam B passes through the projection system PS, which focuses the beam onto a target portion C of the substrate W. The projection system has a pupil PPU conjugate to an illumination system pupil IPU. Portions of radiation emanate from the intensity distribution at the illumination system pupil IPU and traverse a mask pattern without being affected by diffraction at a mask pattern and create an image of the intensity distribution at the illumination system pupil IPU.

[0037] With the aid of the second positioner PW and position sensor IF (for example, an interferometric device, linear encoder, or capacitive sensor), the substrate table WT can be moved accurately (for example, so as to position different target portions C in the path of the radiation beam B). Similarly, the first positioner PM and another position sensor (not shown in FIG. 1B) can be used to accurately position the mask MA with respect to the

path of the radiation beam B (for example, after mechanical retrieval from a mask library or during a scan).

[0038] In general, movement of the mask table MT can be realized with the aid of a long-stroke module (coarse positioning) and a short-stroke module (fine positioning), which form part of the first positioner PM. Similarly, movement of the substrate table WT can be realized using a long-stroke module and a short-stroke module, which form part of the second positioner PW. In the case of a stepper (as opposed to a scanner), the mask table MT can be connected to a short-stroke actuator only or can be fixed. Mask MA and substrate W can be aligned using mask alignment marks M1, M2, and substrate alignment marks P1, P2. Although the substrate alignment marks (as illustrated) occupy dedicated target portions, they can be located in spaces between target portions (known as scribe-lane alignment marks). Similarly, in situations in which more than one die is provided on the mask MA, the mask alignment marks can be located between the dies.

[0039] Mask table MT and patterning device MA can be in a vacuum chamber, where an in-vacuum robot IVR can be used to move patterning devices such as a mask in and out of vacuum chamber. Alternatively, when mask table MT and patterning device MA are outside of the vacuum chamber, an out-of-vacuum robot can be used for various transportation operations, similar to the in-vacuum robot IVR. Both the in-vacuum and out-of-vacuum robots need to be calibrated for a smooth transfer of any payload (e.g., mask) to a fixed kinematic mount of a transfer station.

[0040] The lithographic apparatus 100 and 100' can be used in at least one of the following modes:

[0041] 1. In step mode, the support structure (for example, mask table) MT and the substrate table WT are kept essentially stationary, while an entire pattern imparted to the radiation beam B is projected onto a target portion C at one time (i.e., a single static exposure). The substrate table WT is then shifted in the X and/or Y direction so that a different target portion C can be exposed.

[0042] 2. In scan mode, the support structure (for example, mask table) MT and the substrate table WT are scanned synchronously while a pattern imparted to the radiation beam B is projected onto a target portion C (i.e., a single dynamic exposure). The velocity and direction of the substrate table WT relative to the support structure (for example, mask table) MT can be determined by the (de-)magnification and image reversal characteristics of the projection system PS.

[0043] 3. In another mode, the support structure (for example, mask table) MT is kept substantially stationary holding a programmable patterning device, and the substrate table WT is moved or scanned while a pattern imparted to the radiation beam B is projected onto a target portion C. A pulsed radiation source SO can be employed and the programmable patterning device is updated as required after each movement of the substrate table WT or in between successive radiation pulses during a scan. This mode of operation can be readily applied to maskless lithography that utilizes a programmable patterning device, such as a programmable mirror array.

[0044] Combinations and/or variations on the described modes of use or entirely different modes of use can also be employed.

[0045] In a further embodiment, lithographic apparatus 100 includes an extreme ultraviolet (EUV) source, which is configured to generate a beam of EUV radiation for EUV lithography. In general, the EUV source is configured in a radiation system, and a corresponding illumination system is configured to condition the EUV radiation beam of the EUV source.

[0046] FIG. 2 shows the lithographic apparatus 100 in more detail, including the source collector apparatus SO, the illumination system IL, and the projection system PS. The source collector apparatus SO is constructed and arranged such that a vacuum environment can be maintained in an enclosing structure 220 of the source collector apparatus SO. An EUV radiation emitting plasma 210 may be formed by a discharge produced plasma source. EUV radiation may be produced by a gas or vapor, for example Xe gas, Li vapor or Sn vapor in which the very hot plasma 210 is created to emit radiation in the EUV range of the electromagnetic spectrum. The very hot plasma 210 is created by, for example, an electrical discharge causing an at least partially ionized plasma. Partial pressures of, for example, 10 Pa of Xe, Li, Sn vapor or any other suitable gas or vapor may be required for efficient generation of the radiation. In an embodiment, a plasma of excited tin (Sn) is provided to produce EUV radiation.

[0047] The radiation emitted by the hot plasma 210 is passed from a source chamber 211 into a collector chamber 212 via an optional gas barrier or contaminant trap 230 (in some cases also referred to as contaminant barrier or foil trap) which is positioned in or behind an opening in source chamber 211. The contaminant trap 230 may include a channel structure. Contamination trap 230 may also include a gas barrier or a combination of a gas barrier and a channel structure. The contaminant trap or contaminant barrier 230 further indicated herein at least includes a channel structure, as known in the art.

[0048] The collector chamber 212 may include a radiation collector CO which may be a so-called grazing incidence collector. Radiation collector CO has an upstream radiation collector side 251 and a downstream radiation collector side 252. Radiation that traverses collector CO can be reflected off a grating spectral filter 240 to be focused in a virtual source point IF. The virtual source point IF is commonly referred to as the intermediate focus, and the source collector apparatus is arranged such that the intermediate focus IF is located at or near an opening 219 in the enclosing structure 220. The virtual source point IF is an image of the radiation emitting plasma 210. Grating spectral filter 240 is used in particular for suppressing infra-red (IR) radiation.

5 [0049] Subsequently the radiation traverses the illumination system IL, which may include a faceted field mirror device 222 and a faceted pupil mirror device 224 arranged to provide a desired angular distribution of the radiation beam 221, at the patterning device MA, as well as a desired uniformity of radiation intensity at the patterning device MA. Upon reflection of the beam of radiation 221 at the patterning device MA, held by the support structure MT, a patterned beam 226 is formed and the patterned beam 226 is imaged by the projection system PS via reflective elements 228, 230 onto a substrate W held by the wafer stage or substrate table WT.

10 [0050] More elements than shown may generally be present in illumination optics unit IL and projection system PS. The grating spectral filter 240 may optionally be present, depending upon the type of lithographic apparatus. Further, there may be more mirrors present than those shown in the FIGs., for example there may be 1- 6 additional reflective elements present in the projection system PS than shown in FIG. 2.

15 [0051] Collector optic CO, as illustrated in FIG. 2, is depicted as a nested collector with grazing incidence reflectors 253, 254 and 255, just as an example of a collector (or collector mirror). The grazing incidence reflectors 253, 254 and 255 are disposed axially symmetric around an optical axis O and a collector optic CO of this type is preferably used in combination with a discharge produced plasma source, often called a DPP source.

[0052] *Example Lithographic Cell*

[0053] FIG. 3 shows a lithographic cell 300, also sometimes referred to a lithocell or cluster. Lithographic apparatus 100 or 100' may form part of lithographic cell 300. Lithographic cell 300 may also include apparatus to perform pre- and post-exposure processes on a substrate. Conventionally these include spin coaters SC to deposit resist layers, developers DE to develop exposed resist, chill plates CH and bake plates BK. A substrate handler, or robot, RO picks up substrates from input/output ports I/O1, I/O2, moves

them between the different process apparatus and delivers then to the loading bay LB of the lithographic apparatus. These devices, which are often collectively referred to as the track, are under the control of a track control unit TCU which is itself controlled by the supervisory control system SCS, which also controls the lithographic apparatus via lithography control unit LACU. Thus, the different apparatus can be operated to maximize throughput and processing efficiency.

[0054] *Example Scatterometers*

[0055] In order to ensure that the substrates that are exposed by a lithographic apparatus, such as lithographic apparatus 100 and/or 100' are exposed correctly and consistently, it is desirable to inspect exposed substrates to measure properties such as overlay errors between subsequent layers, line thicknesses, critical dimensions (CD), etc. If errors are detected, adjustments may be made to exposures of subsequent substrates, especially if the inspection can be done soon and fast enough that other substrates of the same batch are still to be exposed. Also, already exposed substrates may be stripped and reworked – to improve yield – or discarded, thereby avoiding performing exposures on substrates that are known to be faulty. In a case where only some target portions of a substrate are faulty, further exposures can be performed only on those target portions which are good.

[0056] An inspection apparatus may be used to determine the properties of the substrates, and in particular, how the properties of different substrates or different layers of the same substrate vary from layer to layer. The inspection apparatus may be integrated into a lithographic apparatus, such as lithographic apparatus 100 and/or 100' or lithocell 300 or may be a stand-alone device. To enable most rapid measurements, it is desirable that the inspection apparatus measure properties in the exposed resist layer immediately after the exposure. However, the latent image in the resist has a very low contrast – there is only a very small difference in refractive index between the parts of the resist which have been exposed to radiation and those which have not – and not all inspection apparatus have sufficient sensitivity to make useful measurements of the latent image. Therefore measurements may be taken after the post-exposure bake step (PEB) which is customarily the first step carried out on exposed substrates and increases the contrast between exposed and unexposed parts of the resist. At this stage, the image in the resist may be referred to as semi-latent. It is also possible to make measurements of the developed resist image – at which point either the exposed or unexposed parts of the resist have been removed – or after a pattern transfer step such as etching. The latter possibility limits the possibilities for rework of faulty substrates but may still provide useful information.

[0057] FIG. 4 depicts a scatterometer SM1 which may be used in the present invention. Scatterometer SM1 may be integrated into a lithographic apparatus, such as lithographic apparatus 100 and/or 100' or lithocell 300 or may be a stand-alone device. It comprises a broadband (white light) radiation projector 2 which projects radiation onto a substrate W. The reflected radiation is passed to a spectrometer detector 4, which measures a spectrum 10 (intensity as a function of wavelength) of the specular reflected radiation. From this data, the structure or profile giving rise to the detected spectrum may be reconstructed by processing unit PU, e.g., by Rigorous Coupled Wave Analysis and non-linear regression or by comparison with a library of simulated spectra as shown at the bottom of FIG. 4. In general, for the reconstruction the general form of the structure is known and some parameters are assumed from knowledge of the process by which the structure was made, leaving only a few parameters of the structure to be determined from the scatterometry data. Such a scatterometer may be configured as a normal-incidence scatterometer or an oblique-incidence scatterometer.

[0058] Another scatterometer SM2 that may be used with the present invention is shown in FIG. 5. Scatterometer SM2 may be integrated into a lithographic apparatus, such as lithographic apparatus 100 and/or 100' or lithocell 300 or may be a stand-alone device. Scatterometer SM2 may include an optical system 1 having a radiation source 2, a lens system 12, a filter 13 (e.g., interference filter), a reflecting device 14 (e.g., reference mirror), a lens system 15 (e.g., a microscopic objective lens system, also referred herein as objective lens system), a partially reflected surface 16 (e.g., a beam splitter), and a polarizer 17. Scatterometer SM2 may further include a detector 18 and a processing unit PU.

[0059] Objective lens system 15 may have a high numerical aperture (NA), e.g., at least 0.9 or at least 0.95. Immersion scatterometers may even have objective lenses with numerical apertures over 1.

[0060] In one exemplary operation, the radiation emitted by radiation source 2 is collimated using lens system 12 and transmitted through interference filter 13 and polarizer 17, is reflected by partially reflected surface 16 and is focused onto substrate W via microscope objective lens system 15. The reflected radiation then transmits through partially reflecting surface 16 into a detector 18 in order to have the scatter spectrum detected. The detector may be located in the back-projected pupil plane 11, which is at the focal length of the objective lens system 15, however the pupil plane may instead be re-imaged with auxiliary optics (not shown) onto the detector. The pupil plane is the plane in which the radial position of radiation defines the angle of incidence and the angular position defines azimuth

angle of the radiation. In one example, the detector is a two-dimensional detector so that a two-dimensional angular scatter spectrum of a substrate target 30 can be measured. The detector 18 may be, for example, an array of CCD or CMOS sensors, and may use an integration time of, for example, 40 milliseconds per frame.

5 **[0061]** A reference beam may be used, for example, to measure the intensity of the incident radiation. To do this, when the radiation beam is incident on beam splitter 16 part of it is transmitted through the beam splitter as a reference beam towards reference mirror 14. The reference beam is then projected onto a different part of the same detector 18 or alternatively on to a different detector (not shown).

10 **[0062]** Interference filter 13 may include a set of interference filters, which may be available to select a wavelength of interest in the range of, say, 405 - 790 nm or even lower, such as 200 - 300 nm. The interference filter may be tunable rather than comprising a set of different filters. A grating could be used instead of interference filters.

[0063] Detector 18 may measure the intensity of scattered light at a single
15 wavelength (or narrow wavelength range), the intensity separately at multiple wavelengths or integrated over a wavelength range. Furthermore, detector 18 may separately measure the intensity of transverse magnetic- and transverse electric-polarized light and/or the phase difference between the transverse magnetic- and transverse electric-polarized light.

[0064] Using a broadband light source (i.e., one with a wide range of light
20 frequencies or wavelengths – and therefore of colors) for a radiation source 2 may give a large etendue, allowing the mixing of multiple wavelengths. The plurality of wavelengths in the broadband preferably each may have a bandwidth of $\Delta\lambda$ and a spacing of at least $2 \Delta\lambda$ (i.e., twice the bandwidth). Several “sources” of radiation can be different portions of an extended radiation source which have been split using fiber bundles. In this way, angle
25 resolved scatter spectra can be measured at multiple wavelengths in parallel. A 3-D spectrum (wavelength and two different angles) can be measured, which contains more information than a 2-D spectrum. This allows more information to be measured which increases metrology process robustness. This is described in more detail in EP1,628,164A, which is incorporated by reference herein in its entirety.

30 **[0065]** The target 30 on substrate W may be a 1-D grating, which is printed such that after development, the bars are formed of solid resist lines. The target 30 may be a 2-D grating, which is printed such that after development, the grating is formed of solid resist pillars or vias in the resist. The bars, pillars or vias may alternatively be etched into the substrate. This pattern is sensitive to chromatic aberrations in the lithographic projection

apparatus, particularly the projection system PL, and illumination symmetry and the presence of such aberrations will manifest themselves in a variation in the printed grating. Accordingly, the scatterometry data of the printed gratings is used to reconstruct the gratings. The parameters of the 1-D grating, such as line widths and shapes, or parameters of the 2-D grating, such as pillar or via widths or lengths or shapes, may be input to the reconstruction process, performed by processing unit PU, from knowledge of the printing step and/or other scatterometry processes.

[0066] As described above, the target can be on the surface of the substrate. This target will often take the shape of a series of lines in a grating or substantially rectangular structures in a 2-D array. The purpose of rigorous optical diffraction theories in metrology is effectively the calculation of a diffraction spectrum that is reflected from the target. In other words, target shape information is obtained for CD (critical dimension) uniformity and overlay metrology. Overlay metrology is a measuring system in which the overlay of two targets is measured in order to determine whether two layers on a substrate are aligned or not. CD uniformity is simply a measurement of the uniformity of the grating on the spectrum to determine how the exposure system of the lithographic apparatus is functioning. Specifically, CD, or critical dimension, is the width of the object that is “written” on the substrate and is the limit at which a lithographic apparatus is physically able to write on a substrate.

[0067] *Objective Lens System according to a First Embodiment*

[0068] FIG. 6 illustrates a schematic of a cross-sectional view of a refractive objective lens system 600 that can be implemented as a part of scatterometers SM1 and/or SM2 (shown in Figs. 4 and 5), according to an embodiment. In an example of this embodiment, objective lens system 600 may be used for directing and/or focusing a radiation beam emitted from an illumination system (not shown) onto an object of inspection (e.g., patterning device MA, target 30 on substrate W, target portion C), and for collecting and/or imaging the scattered or reflected light from the object of inspection.

[0069] Objective lens system 600 may be configured to have a high NA (e.g., NA equal to about 0.95, NA greater than about 0.95, NA equal to about 1) without central obscuration, a large working distance (e.g., greater than about 0.35, greater than about 0.5) and low optical aberrations (e.g., low chromatic aberrations, low field curvature aberrations, low pupil aberrations, low apochromatic aberrations) compared to current objective lens system. Additionally, objective lens system 600 may be configured to have a focal length ranging from about 3.5 mm to about 3.6 mm. Further, objective lens system 600 may be

configured to operate over a wider spectral band of wavelengths (e.g., between 450-700 nm wavelengths, below 450 nm wavelength, above 700 nm wavelength, between 410-450 nm wavelengths, between 700-900 nm wavelengths, at deep ultra violet (DUV) wavelengths, at infrared (IR) wavelengths) compared to current objective lens systems without compromising optical performance.

[0070] According to an example of this embodiment, objective lens system 600 may comprise a front lens group 601, a middle lens group 602, and a back lens group 603. Front lens group 601, middle lens group 602, and back lens group 603 may be optically coupled to each other and may be arranged along optical axis 650 of objective lens system 600.

[0071] Front lens group 601 may be configured to decrease NA from an object space 656 to the entrance of middle lens group 602, according to an example of this embodiment. For example, front lens group 601 may decrease NA from about 0.95 in the object space to about 0.25-0.4 at the entrance of middle lens group 602. According to another example, front lens group 601 may be configured to simultaneously correct or reduce coma aberrations and chromatic aberrations (axial color aberrations) of objective lens system 600. Such configurations of front lens group 601 may be dependent on composition and arrangement of one or more lenses in front lens group 601.

[0072] In an example of this embodiment, front lens group 601 may comprise a first positive meniscus lens 604 and a second positive meniscus lens 606 that are optically coupled to each other (shown in FIG. 6). First positive meniscus lens 604 may have a spherical concave surface 604a and a spherical convex surface 604b, and second positive meniscus lens 606 may have a spherical concave surface 606a and a spherical convex surface 606b. Convex surface 604b may have a radius of curvature that is smaller than a radius of curvature of convex surface 606b. Convex surface 604b may be in substantial contact with concave surface 606a at least at a point A along optical axis 650, according to an example. In another example, an air gap ranging from about 2% to about 8% of the focal length of objective lens system 600 may be present between convex surface 604b and concave surface 606a along optical axis 650.

[0073] First positive meniscus lens 604 may comprise, e.g., a heavy crown glass, a heavy flint glass, a lanthanum flint glass, a lanthanum dense flint glass, or a combination thereof having a refractive index greater than about 1.75, according to various examples of this embodiment. In other examples of this embodiment, first positive meniscus

lens 604 may comprise an optical material having an Abbe number that ranges from about 45 to about 50, that is greater than 50, or that is greater than 70.

[0074] One lens parameter is its Abbe number, which is a measure of the material's dispersion (variation of refractive index with wavelength) in relation to the refractive index. High Abbe numbers indicate low dispersion (low chromatic aberration), and vice versa. Second positive meniscus lens 606 may comprise a heavy flint glass having an Abbe number and a refractive index smaller than the Abbe number and refractive index of first positive meniscus lens 604. For example, second positive meniscus lens 606 may have an Abbe number less than about 30 and a refractive index that ranges from about 1.5 to about 1.6. The large difference (e.g., greater than about 15) in the Abbe numbers of first positive meniscus lens 604 and second positive meniscus lens 606 may allow the correction or reduction of coma and chromatic aberrations by front lens group 601. For example, if first positive meniscus lens 604 comprises an optical material having an Abbe number of about 45 and second positive meniscus lens 606 comprises an optical material having an Abbe number of about 29, the difference in Abbe numbers is equal to about 16.

[0075] In an embodiment, middle lens group 602 may be configured to correct or reduce apochromatic aberrations of objective lens system 600. Such configuration of middle lens group 602 may be dependent on composition and arrangement of one or more lenses in middle lens group 602. Middle lens group 602 may comprise a first doublet lens 608, a second doublet lens 610, a triplet lens 612, and a third doublet 614, as shown in FIG. 6, according to an example of this embodiment.

[0076] First doublet lens 608 may comprise a bi-concave lens 616 and a bi-convex lens 618 and may be positioned in a manner that first bi-concave lens 616 is in substantial contact with second positive meniscus lens 606 at least at a point B along optical axis 650, as illustrated in FIG. 6. Also, as illustrated in FIG. 6, bi-concave lens 616 may have a thickness along optical axis 650 that is smaller than a thickness of bi-convex lens 618 along optical axis 650. Bi-concave lens 616 and bi-convex lens 618 may be coupled together and may have spherical surfaces. The coupling of bi-concave lens 616 and bi-convex lens 618 may be achieved by cementing these lenses to each other, according to an example. The lenses may be cemented by an adhesive (e.g., optically transparent epoxy) with mechanical strength to hold these lenses together. In another example, bi-concave lens 616 and bi-convex lens 618 may be coupled by holding these lenses pressed against each other with external mounting fixtures because the optical design may require an infinitesimal air gap between these lenses or because the difference in thermal expansion coefficients of these lenses does

not allow cementing. The external mounting fixtures may hold these lenses together in a manner such that a partial or an entire surface of bi-concave lens 616 is in substantial contact with a partial or an entire surface of bi-convex lens 618. Bi-concave lens 616 and bi-convex lens 618 may comprise materials such as, but not limited to, crown glass or flint glass. Both
5 bi-concave lens 616 and bi-convex lens 618 may comprise the same material or different material with respect to each other.

[0077] Second doublet lens 610 may comprise a bi-concave lens 620 and a bi-convex lens 622 and may be positioned in a manner that bi-concave lens 620 is in substantial contact with bi-convex surface 618 at least at a point C along optical axis 650, as illustrated
10 in FIG. 6. Also, as illustrated in FIG. 6, bi-concave lens 620 may have a thickness along optical axis 650 that is smaller than a thickness of bi-convex lens 622 along optical axis 650. Bi-concave lens 620 and bi-convex lens 622 may have spherical surfaces and may be coupled together by cementing or by holding together, as described above with reference to bi-concave lens 616 and bi-convex lens 618. Bi-concave lens 620 and bi-convex lens 622 may
15 comprise materials such as, but not limited to, crown glass material or flint glass material. Both bi-concave lens 620 and bi-convex lens 622 may comprise the same material or different material with respect to each other.

[0078] Triplet lens 612 may comprise a positive meniscus lens 624, a negative meniscus lens 626, and a bi-convex lens 628 and may be positioned in a manner that positive
20 meniscus lens 624 is in substantial contact with bi-convex surface 622 at least at a point D along optical axis 650, as illustrated in FIG. 6. Positive meniscus lens 624, negative meniscus lens 626, and bi-convex lens 628 may have spherical surfaces and may be coupled together by cementing or by holding together, as described above with reference to bi-concave lens 616 and bi-convex lens 618.

[0079] In one example, bi-convex lens 628 may have a thickness along optical axis
25 650 that is greater than each thickness of positive meniscus lens 624 and negative meniscus lens 626 along optical axis 650. In another example, bi-convex lens 628 may have a thickness along optical axis 650 that is greater than combined thickness of positive meniscus lens 624 and negative meniscus lens 626 along optical axis 650. In a further example, thickness of
30 positive meniscus lens 624 and thickness of negative meniscus lens 626 along optical axis 650 is equal or different with respect to each other.

[0080] According to an example, positive meniscus lens 624 may comprise calcium fluoride (CaF_2), negative meniscus lens 626 may comprise a heavy crown glass, a heavy flint glass, a lanthanum flint glass, or a lanthanum dense flint glass, and bi-convex lens

628 may comprise a heavy flint glass having a refractive index that is greater than about 1.75. These combinations of glass materials in triplet lens 612 may allow middle lens group 602 to correct or reduce apochromatic aberrations of objective lens system 600.

[0081] As further illustrated in FIG. 6, third doublet lens 614 may comprise a
5 bi-convex lens 630 and a positive meniscus lens 632 and may be positioned in a manner that bi-convex lens 630 is in substantial contact with bi-convex lens 628 at least at a point E along optical axis 650. Also, as illustrated in FIG. 6, bi-convex lens 630 may have a thickness along optical axis 650 that is greater than a thickness of positive meniscus lens 632 along optical axis 650. Bi-convex lens 630 and positive meniscus lens 632 may have spherical surfaces and
10 may be coupled together by cementing or by holding together, as described above with reference to bi-concave lens 616 and bi-convex lens 618.

[0082] According to an embodiment, back lens group 603 may be configured to correct or reduce field curvature (also sometimes referred as Petzval curvature in the art) aberrations and pupil aberrations of objective lens system 600. Such configuration of back
15 lens group 603 may be dependent on composition and arrangement of one or more lenses in back lens group 603. Back lens group 603 may comprise a bi-convex lens 634 and a doublet lens 636 that are placed adjacent to each other, but are not in contact with each other, as shown in FIG. 6, according to an example of this embodiment. Doublet lens 636 may comprise a bi-convex lens 638 and a bi-concave lens 640. Bi-convex lens 638 may have a
20 thickness along optical axis 650 that is greater than each thickness of bi-concave lenses 634 and 640 along optical axis 650. Bi-convex lens 638 and bi-concave lens 640 may have spherical surfaces and may be coupled together by cementing or by holding together, as described above with reference to bi-concave lens 616 and bi-convex lens 618.

[0083] Further, as illustrated in FIG. 6, objective lens system 600 may
25 comprise an aperture stop 652 and an entrance pupil 654 that may be located along optical axis 650 and between middle lens group 602 and back group lens 603, according to an example of this embodiment. Location of entrance pupil 626 between middle lens group 602 and back lens group 618 may allow a diameter of aperture stop 624 to be adjusted.

[0084] ***Objective Lens System according to a Second Embodiment***

30 [0085] FIG. 7 illustrates a schematic of a cross-sectional view of a refractive objective lens system 700 that can be implemented as a part of scatterometers SM1 and/or SM2 (shown in Figs. 4 and 5), according to an embodiment. Objective lens system 700 shares many similar features and configurations with objective lens system 600. Therefore, only differences between objective lens systems 600 and 700 are to be discussed below.

[0086] According to an example of this embodiment, objective lens system 700 may comprise a front lens group 601, a middle lens group 602, and a back lens group 703. Front lens group 601, middle lens group 602, and back lens group 703 may be optically coupled to each other and may be arranged along optical axis 750 of objective lens system 700.

[0087] Back lens group 703 may comprise a bi-convex lens 707 interposed between two bi-concave lenses 709 and 711, according to an example of this embodiment. Bi-convex lens 638 and bi-concave lenses 709 and 711 may have spherical surfaces and may be coupled together to form a triplet lens by cementing or by holding together, as described above with reference to bi-concave lens 616 and bi-convex lens 618 (shown in FIG. 6). Bi-convex lens 707 may have a thickness along optical axis 750 that is greater than each thickness of bi-concave lenses 709 and 711 along optical axis 750. Such combination of lenses may allow back group lens 703 to correct or reduce field curvature aberrations and pupil aberrations of objective lens system 700.

[0088] ***Objective Lens System according to a Third Embodiment***

[0089] FIG. 8 illustrates a schematic of a cross-sectional view of a refractive objective lens system 800 that can be implemented as a part of scatterometers SM1 and/or SM2 (shown in Figs. 4 and 5), according to an embodiment. Objective lens system 800 shares many similar features and configurations with objective lens systems 600 and 700. Therefore, only differences between objective lens systems 600, 700, and 800 are to be discussed below.

[0090] According to an example of this embodiment, objective lens system 800 may comprise a front lens group 801, a middle lens group 602, and a back lens group 703. Front lens group 801, middle lens group 602, and back lens group 703 may be optically coupled to each other and may be arranged along optical axis 850 of objective lens system 700.

[0091] Front lens group 801 is similar to front lens group 601 (shown in FIGs. 6-7), except that front lens group 801 includes an aspherical meniscus lens 805 instead of the positive spherical meniscus lens 606 of front lens group 601. Aspherical meniscus lens 805 may have an aspherical concave surface 805a and a spherical convex surface 805b. Aspherical concave surface 805a may be in substantial contact with spherical convex surface 803a at least at a point F along optical axis 850, according to an example. In another example, an air gap ranging from about 2% to about 8% of the focal length of objective lens system 800 may be present between aspherical concave surface 805a and spherical convex surface 803a along optical axis 850. Presence of aspherical concave surface 805a in front lens group

801 may offer optimal aberration correction and as a result higher resolution compared to front lens group 601 as aspherical surfaces inherently produce less optical aberrations (e.g., spherical aberrations) than spherical surfaces. In an example of this embodiment, aspherical meniscus lens 805 may comprise a heavy flint glass having an Abbe number and a refractive index similar to the Abbe number and refractive index of second positive meniscus lens 606 of front lens group 601.

[0092] *Objective Lens System according to a Fourth Embodiment*

[0093] FIG. 9 illustrates a schematic of a cross-sectional view of a refractive objective lens system 900 that can be implemented as a part of scatterometers SM1 and/or SM2 (shown in Figs. 4 and 5), according to an embodiment. Objective lens system 900 shares many similar features and configurations with objective lens systems 600, 700, and 800. Therefore, only differences between objective lens systems 600, 700, and 800 are to be discussed below.

[0094] According to an example of this embodiment, objective lens system 900 may comprise a front lens group 601, a middle lens group 902, and a back lens group 703. Front lens group 601, middle lens group 902, and back lens group 703 may be optically coupled to each other and may be arranged along optical axis 950 of objective lens system 900.

[0095] Middle lens group 902 is similar to middle lens group 602 (shown in FIGs. 6-8), except for the differences described herein. In an example, middle lens group 902 includes a concave lens 905 and a bi-convex lens 907 forming a doublet lens 909 instead of the positive meniscus lens 632 and the bi-convex lens 630 forming the doublet lens 614 of middle lens group 602. In another example, middle group lens 902 includes a triplet lens 911 having meniscus lenses 913 and 915 and a bi-convex lens 917. Radii of curvature of spherical surfaces of meniscus lenses 913 and 915 are smaller than radii of curvature of the spherical surfaces of meniscus lenses 624 and 626 of middle lens group 602. These differences in middle lens group 902 from middle lens group 602 may allow objective lens system 900 to have a focal length smaller than the focal length of objective lens system 600, 700, and/or 800 for the same high NA as the objective lens systems 600, 700, and 800. For example, objective lens system 900 may have a focal length of 2 mm for a NA of 0.95.

[0096] It should be noted that even though objective lens system 900 is shown to include a front lens group similar to front lens group 601 of objective lens 600 and a back lens group similar to back lens group 703 of objective lens 700, objective lens system 900 may include front lens group that is similar to front lens group 801 of objective lens system

800 and/or a back lens group that is similar to back lens group 603 of objective lens system 600, according to various examples of this embodiment.

5 [0097] Although specific reference may be made in this text to the use an objective lens system in inspection system, it should be understood that the objective lens system described herein may have other applications that require a combination of high NA, large field of view (FOV), and/or wide spectral band.

10 [0098] Although specific reference may be made in this text to the use of lithographic apparatus in the manufacture of ICs, it should be understood that the lithographic apparatus described herein may have other applications, such as the manufacture of integrated optical systems, guidance and detection patterns for magnetic domain memories, flat-panel displays, liquid-crystal displays (LCDs), thin-film magnetic heads, *etc.* The skilled artisan will appreciate that, in the context of such alternative applications, any use of the terms “wafer” or “die” herein may be considered as synonymous with the more general terms “substrate” or “target portion”, respectively. The substrate referred to herein may be processed, before or after exposure, in for example a track (a tool that typically applies a layer of resist to a substrate and develops the exposed resist), a metrology tool and/or an inspection tool. Where applicable, the disclosure herein may be applied to such and other substrate processing tools. Further, the substrate may be processed more than once, for example in order to create a multi-layer IC, so that the term substrate used herein may also refer to a substrate that already contains multiple processed layers.

25 [0099] Although specific reference may have been made above to the use of embodiments of the invention in the context of optical lithography, it will be appreciated that the invention may be used in other applications, for example imprint lithography, and where the context allows, is not limited to optical lithography. In imprint lithography a topography in a patterning device defines the pattern created on a substrate. The topography of the patterning device may be pressed into a layer of resist supplied to the substrate whereupon the resist is cured by applying electromagnetic radiation, heat, pressure or a combination thereof. The patterning device is moved out of the resist leaving a pattern in it after the resist is cured.

30 [00100] It is to be understood that the phraseology or terminology herein is for the purpose of description and not of limitation, such that the terminology or phraseology of the present specification is to be interpreted by those skilled in relevant art(s) in light of the teachings herein.

[00101] In the embodiments described herein, the terms “lens” and “lens element,” where the context allows, can refer to any one or combination of various types of optical components, including refractive, reflective, magnetic, electromagnetic, and electrostatic optical components.

5 [00102] Further, the terms “radiation” and “beam” used herein encompass all types of electromagnetic radiation, including ultraviolet (UV) radiation (for example, having a wavelength λ of 365, 248, 193, 157 or 126 nm), extreme ultraviolet (EUV or soft X-ray) radiation (for example, having a wavelength in the range of 5-20 nm such as, for example, 13.5 nm), or hard X-ray working at less than 5 nm, as well as particle beams, such as ion
10 beams or electron beams. Generally, radiation having wavelengths between about 780-3000 nm (or larger) is considered IR radiation. UV refers to radiation with wavelengths of approximately 100-400 nm. Within lithography, the term “UV” also applies to the wavelengths that can be produced by a mercury discharge lamp: G-line 436 nm; H-line 405 nm; and/or, I-line 365 nm. Vacuum UV, or VUV (i.e., UV absorbed by gas), refers to
15 radiation having a wavelength of approximately 100-200 nm. Deep UV (DUV) generally refers to radiation having wavelengths ranging from 126 nm to 428 nm, and in an embodiment, an excimer laser can generate DUV radiation used within a lithographic apparatus. It should be appreciated that radiation having a wavelength in the range of, for example, 5-20 nm relates to radiation with a certain wavelength band, of which at least part is
20 in the range of 5-20 nm.

[0102] The term “substrate” as used herein describes a material onto which subsequent material layers are added. In embodiments, the substrate itself may be patterned and materials added on top of it may also be patterned, or may remain without patterning.

25 [00103] The term “in substantial contact” as used herein generally describes elements or structures that are in physical contact with each other with only a slight separation from each other which typically results from misalignment tolerances. It should be understood that relative spatial descriptions between one or more particular features, structures, or characteristics (*e.g.*, “vertically aligned,” “substantial contact,” *etc.*) used herein
30 are for purposes of illustration only, and that practical implementations of the structures described herein may include misalignment tolerances without departing from the spirit and scope of the present disclosure.

[00104] The term “optically coupled” as used herein generally refers to one coupled element being configured to impart light to another coupled element directly or indirectly.

[00105] The term “optical material” as used herein generally refers to a material that allows light or optical energy to propagate therein or therethrough.

[00106] While specific embodiments of the invention have been described above, it will be appreciated that the invention may be practiced otherwise than as described. The description is not intended to limit the invention.

[00107] It is to be appreciated that the Detailed Description section, and not the Summary and Abstract sections, is intended to be used to interpret the claims. The Summary and Abstract sections may set forth one or more but not all exemplary embodiments of the present invention as contemplated by the inventor(s), and thus, are not intended to limit the present invention and the appended claims in any way.

[00108] The present invention has been described above with the aid of functional building blocks illustrating the implementation of specified functions and relationships thereof. The boundaries of these functional building blocks have been arbitrarily defined herein for the convenience of the description. Alternate boundaries can be defined so long as the specified functions and relationships thereof are appropriately performed.

[00109] The foregoing description of the specific embodiments will so fully reveal the general nature of the invention that others can, by applying knowledge within the skill of the art, readily modify and/or adapt for various applications such specific embodiments, without undue experimentation, without departing from the general concept of the present invention. Therefore, such adaptations and modifications are intended to be within the meaning and range of equivalents of the disclosed embodiments, based on the teaching and guidance presented herein.

[00110] The breadth and scope of the present invention should not be limited by any of the above-described exemplary embodiments, but should be defined only in accordance with the following claims and their equivalents.

WHAT IS CLAIMED IS:

1. An objective lens system comprising:
a first lens group comprising:
a first positive meniscus lens, and
5 a second positive meniscus lens positioned at a distance from the first positive meniscus lens along an optical axis of the objective lens system, the distance being dependent on a focal length of the objective lens system;
a second lens group comprising a triplet lens, wherein the triplet lens comprises:
a first meniscus lens comprising a first surface and a second surface,
10 a second meniscus lens comprising a third surface and a fourth surface, the third surface being in substantial contact with the second surface, and
a first bi-convex lens comprising a fifth surface and a sixth surface, the fifth surface being in substantial contact with the fourth surface; and
a third lens group comprising:
15 a first bi-concave lens; and
a doublet lens.
2. The refractive objective lens system of claim 1, wherein the first lens group is configured to simultaneously correct coma aberrations and chromatic aberrations of the
20 objective lens system.
3. The refractive objective lens system of claim 1, wherein the second lens group is configured to correct apochromatic aberrations of the objective lens system.
- 25 4. The refractive objective lens system of claim 1, wherein the third lens group is configured to correct field curvature aberrations and pupil aberrations of the objective lens system.
5. The refractive objective lens system of claim 1, wherein the first positive meniscus
30 lens and the second positive meniscus lens comprise spherical surfaces.
6. The refractive objective lens system of claim 1, wherein the second positive meniscus lens comprises an aspherical concave surface.

7. The refractive objective lens system of claim 1, wherein the first bi-concave lens and the doublet are adjacent to and separated from each other.
8. The refractive objective lens system of claim 1, wherein the first bi-concave lens and
5 the doublet are cemented to each other.
9. The refractive objective lens system of claim 1, wherein the doublet comprises a second bi-convex lens and a second bi-concave lens cemented to each other.
- 10 10. The refractive objective lens system of claim 1, further comprising an entrance pupil and an aperture stop between the second lens group and the third lens group.
11. An inspection system configured to measure a property of a substrate, the inspection system comprising:
15 a radiation source configured to produce a radiation beam;
an optical system configured to focus the radiation beam on to a surface of the substrate, the optical system comprising:
a first lens group comprising:
a first positive meniscus lens, and
20 a second positive meniscus lens positioned at a distance from the first positive meniscus lens along an optical axis of the optical system, the distance being dependent on a focal length of the optical system,
a second lens group comprising:
a third positive meniscus lens,
25 a negative meniscus lens cemented to the third positive meniscus lens,
and
a bi-convex lens cemented to the negative meniscus lens, and
a third lens group comprising:
a bi-concave lens, and
30 a doublet lens; and
a detector configured to detect the radiation beam reflected from the surface of the substrate.

12. The inspection system of claim 11, wherein the second positive meniscus lens comprises an aspherical concave surface.
13. The inspection system of claim 11, wherein:
5 the third positive meniscus lens comprises calcium fluoride;
the negative meniscus lens comprises a heavy crown glass, a heavy flint glass, a lanthanum flint glass, or a lanthanum dense flint glass; and
the bi-convex lens comprises a heavy flint glass having a refractive index that is greater than about 1.75.
10
14. The inspection system of claim 11, wherein the bi-concave lens and the doublet are adjacent to and separated from each other.
15. The inspection system of claim 11, wherein the bi-concave lens and the doublet are
15 cemented to each other.
16. The inspection system of claim 11, wherein the third lens group is configured to correct field curvature aberrations and pupil aberrations of the optical system.
- 20 17. A lithographic apparatus comprising:
an illumination optical system configured to illuminate a pattern of a patterning device;
a projection system configured to project an image of the pattern on to a target portion of a substrate; and
25 an inspection apparatus configured to measure a property of the substrate comprising an objective lens system, the objective lens system comprising:
a first lens group configured to correct field curvature aberrations and pupil aberrations of the objective lens system, the first lens group comprising:
a bi-concave lens; and
30 a doublet lens.
18. The lithographic apparatus of claim 17, wherein the objective lens system further comprises:
a second lens group comprising:

a first meniscus lens,
a second meniscus lens cemented to the first meniscus lens, and
a bi-convex lens cemented to the second meniscus lens; and

5 a third lens group comprising positive meniscus lenses positioned at a distance from each other along an optical axis of the objective lens system, the distance being dependent on a focal length of the objective lens system.

19. The lithographic apparatus of claim 18, wherein one of the positive meniscus lenses comprises an aspherical concave surface.

10

20. The lithographic apparatus of claim 17, wherein the bi-concave lens and the doublet are cemented to each other.

21. An objective lens system comprising:

15

first and second meniscus lenses positioned at a distance from each other along an optical axis of the objective lens system, the distance being dependent on a focal length of the objective lens system;

third and fourth meniscus lenses in contact with each other;

a bi-convex lens in contact with the fourth meniscus lens;

20

a triplet lens; and

an aperture stop between the triplet lens and the bi-convex lens.

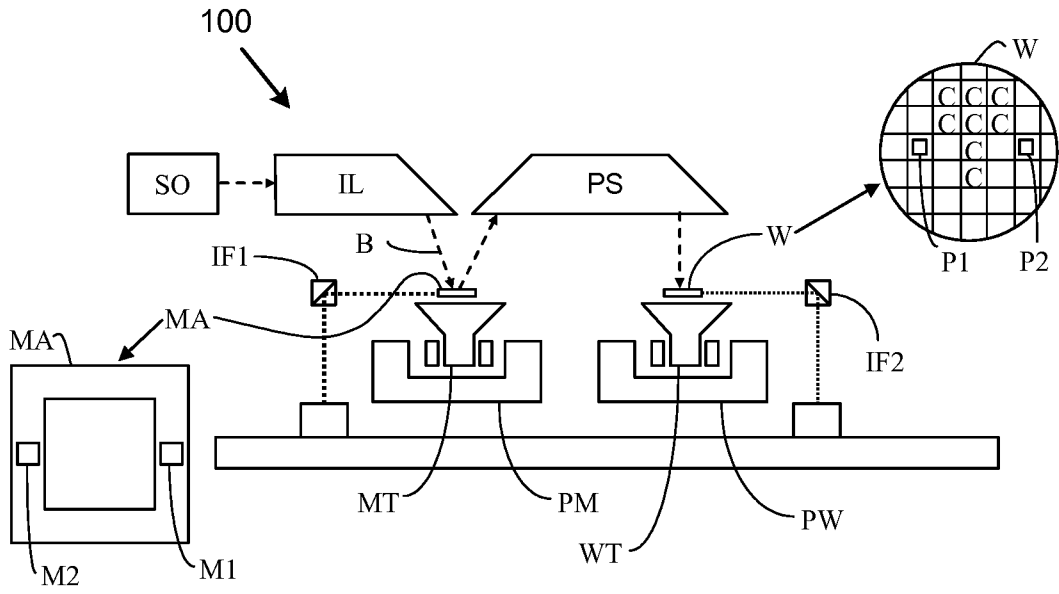

FIG. 1A

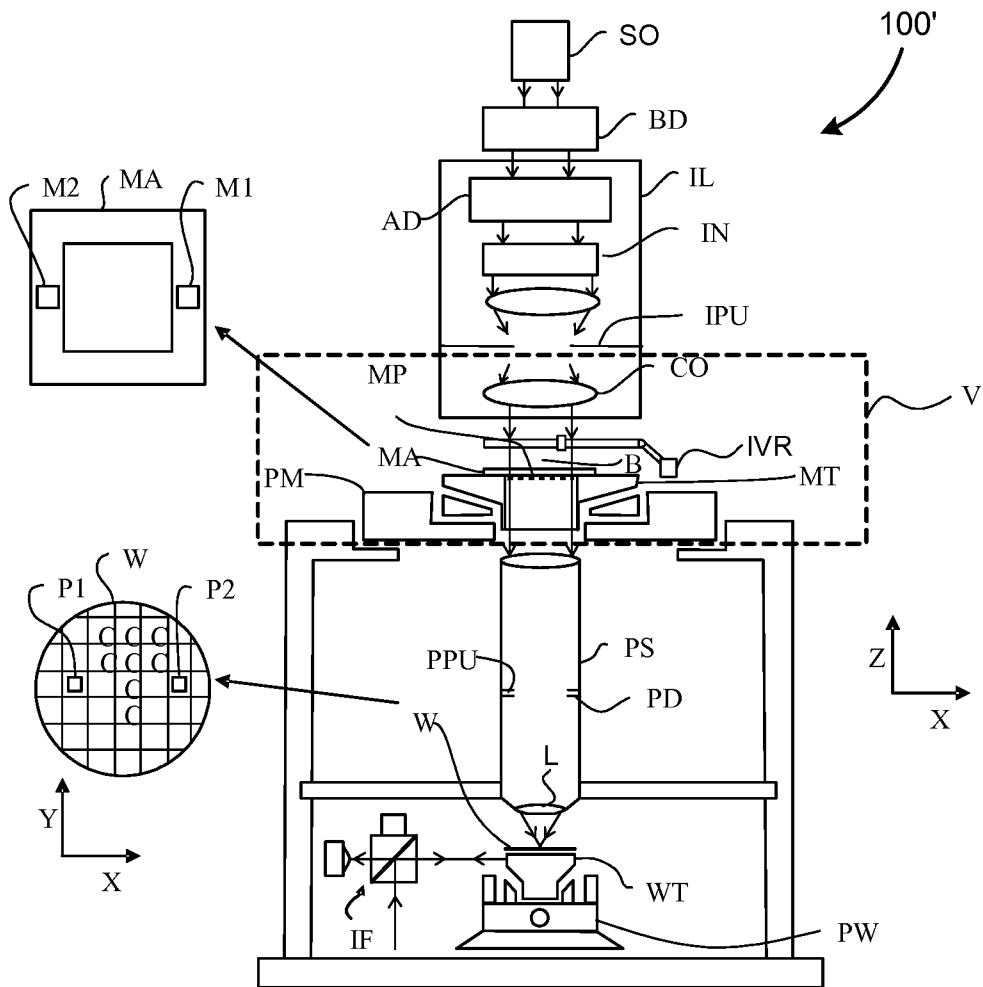

FIG. 1B

2/5

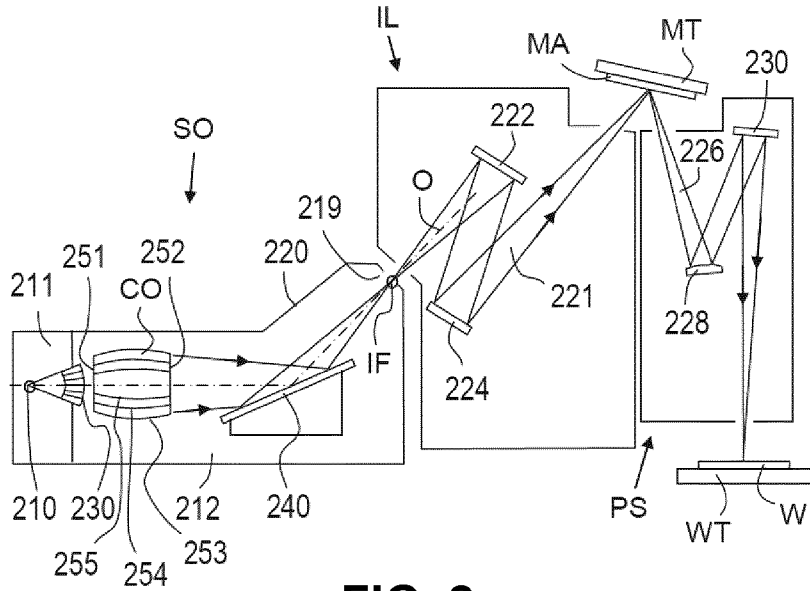

FIG. 2

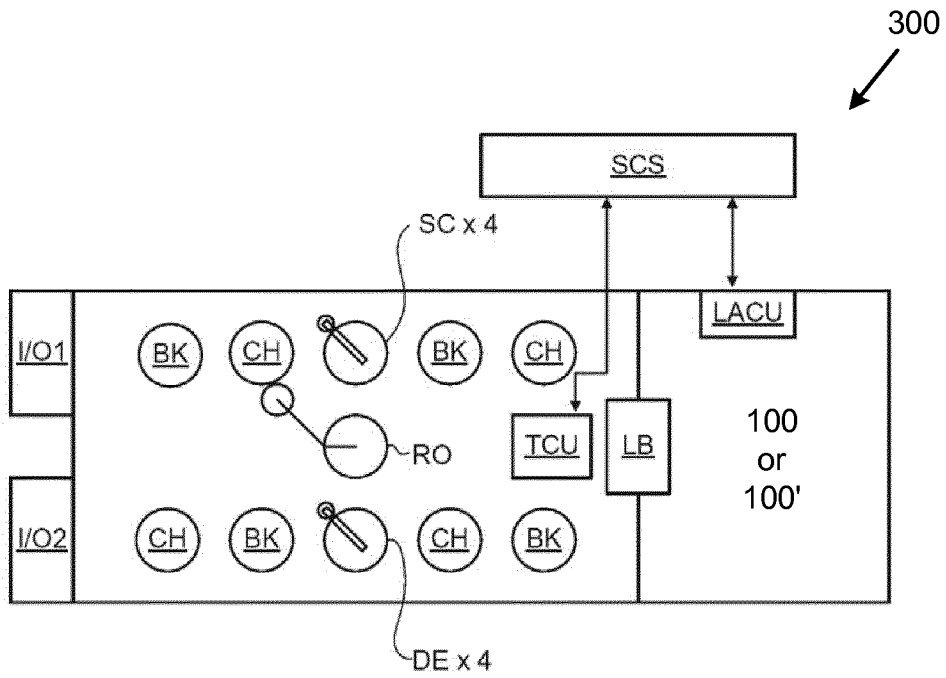

FIG. 3

SM1

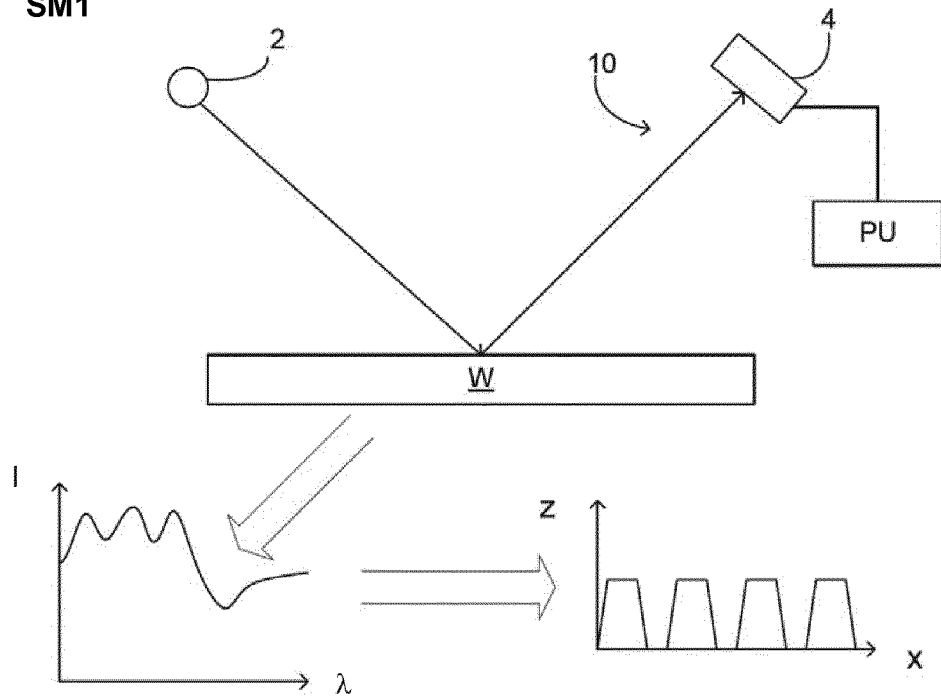

FIG. 4

SM2

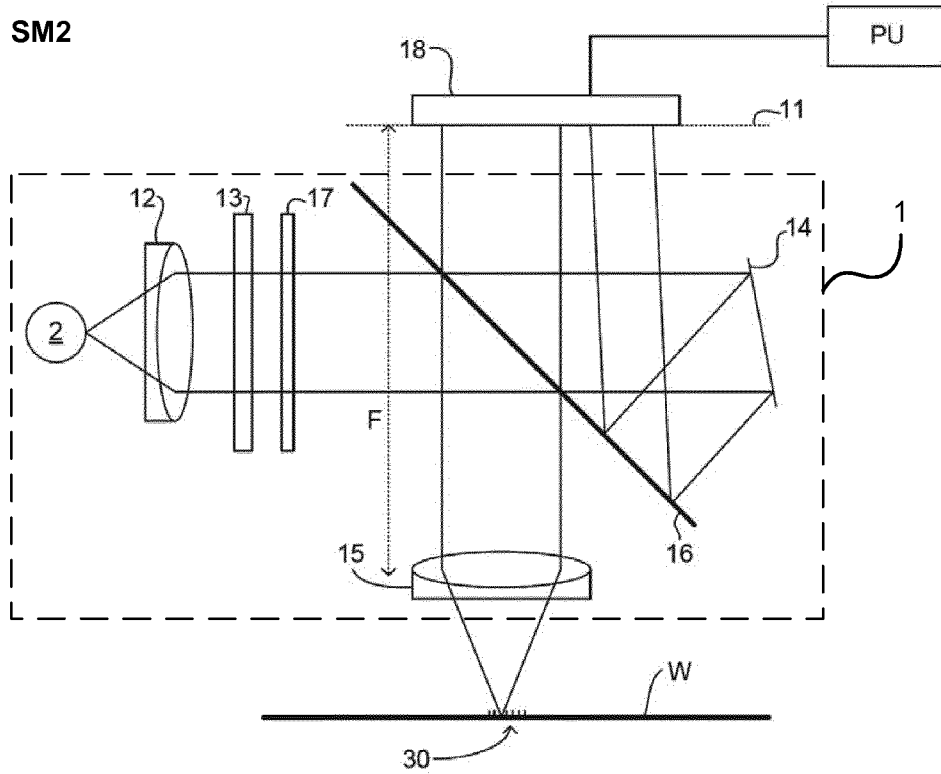

FIG. 5

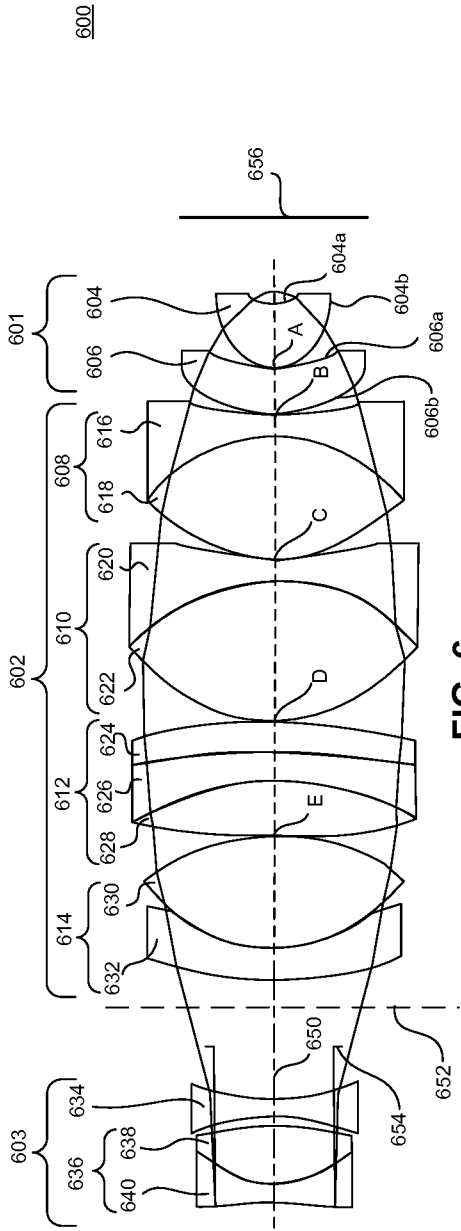

FIG. 6

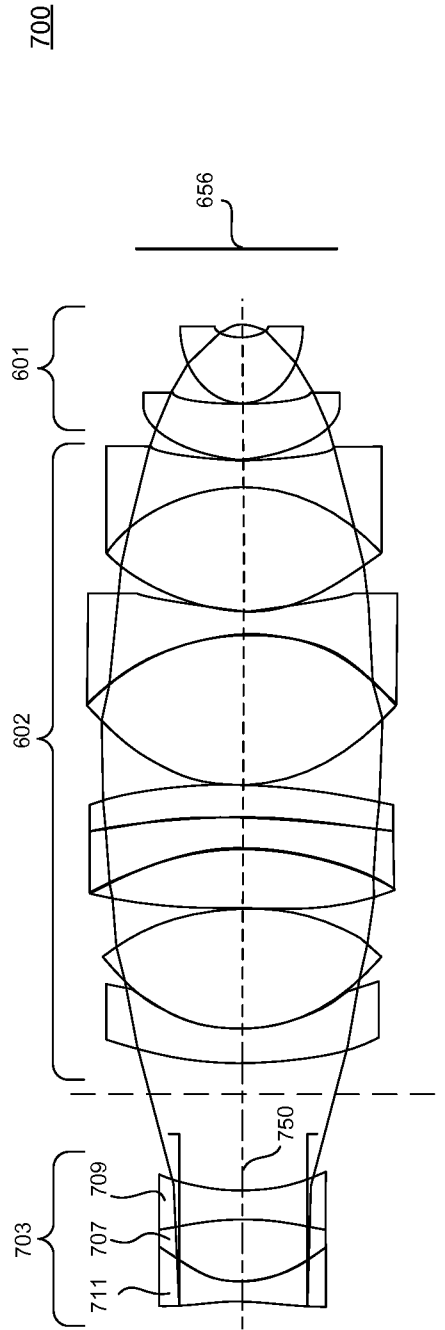

FIG. 7

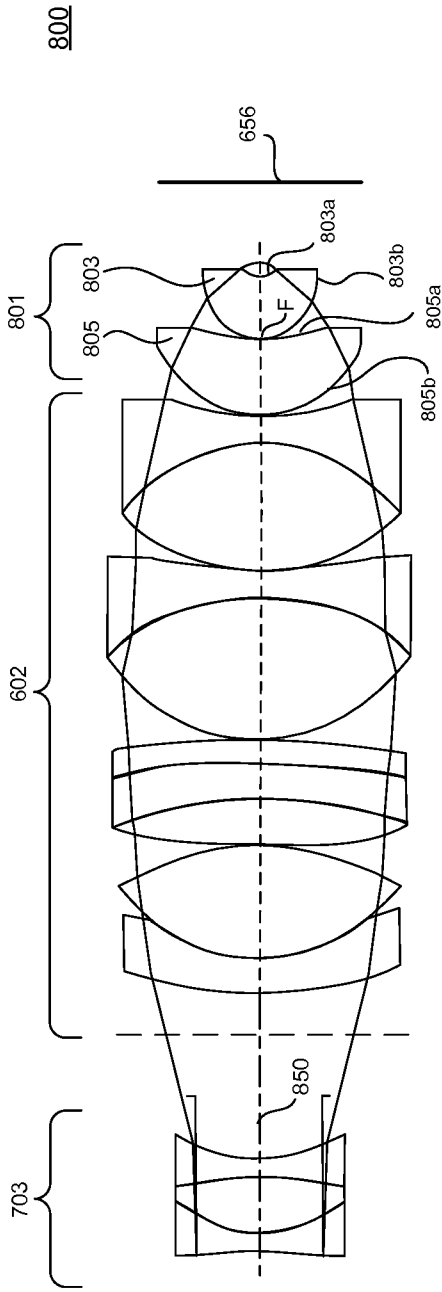

FIG. 8

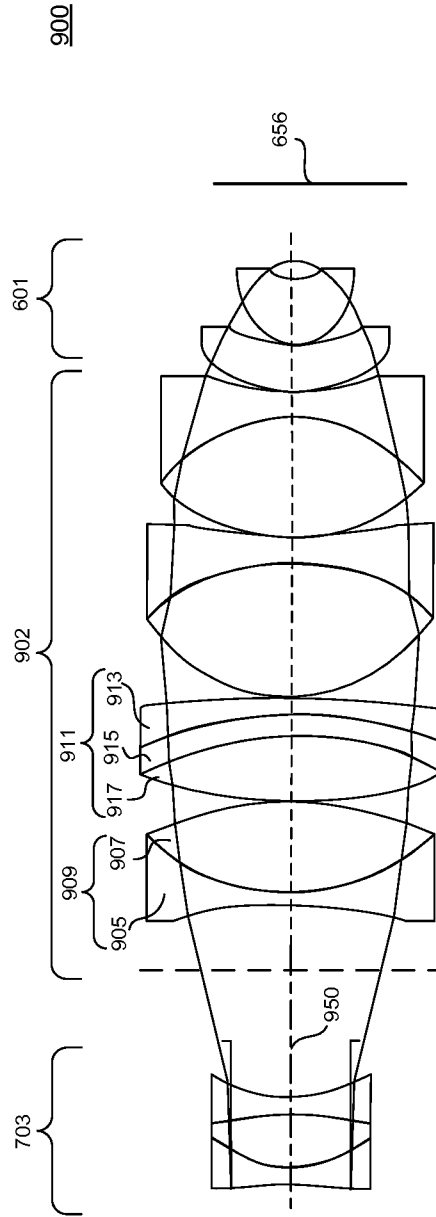

FIG. 9

INTERNATIONAL SEARCH REPORT

International application No.
PCT/EP2015/067352

Box No. II Observations where certain claims were found unsearchable (Continuation of item 2 of first sheet)

This international search report has not been established in respect of certain claims under Article 17(2)(a) for the following reasons:

1. Claims Nos.:
because they relate to subject matter not required to be searched by this Authority, namely:

2. Claims Nos.:
because they relate to parts of the international application that do not comply with the prescribed requirements to such an extent that no meaningful international search can be carried out, specifically:

3. Claims Nos.:
because they are dependent claims and are not drafted in accordance with the second and third sentences of Rule 6.4(a).

Box No. III Observations where unity of invention is lacking (Continuation of item 3 of first sheet)

This International Searching Authority found multiple inventions in this international application, as follows:

see additional sheet

1. As all required additional search fees were timely paid by the applicant, this international search report covers all searchable claims.

2. As all searchable claims could be searched without effort justifying an additional fees, this Authority did not invite payment of additional fees.

3. As only some of the required additional search fees were timely paid by the applicant, this international search report covers only those claims for which fees were paid, specifically claims Nos.:

4. No required additional search fees were timely paid by the applicant. Consequently, this international search report is restricted to the invention first mentioned in the claims; it is covered by claims Nos.:

Remark on Protest

- The additional search fees were accompanied by the applicant's protest and, where applicable, the payment of a protest fee.
- The additional search fees were accompanied by the applicant's protest but the applicable protest fee was not paid within the time limit specified in the invitation.
- No protest accompanied the payment of additional search fees.

INTERNATIONAL SEARCH REPORT

International application No
PCT/EP2015/067352

A. CLASSIFICATION OF SUBJECT MATTER
INV. G02B21/02
ADD.
According to International Patent Classification (IPC) or to both national classification and IPC

B. FIELDS SEARCHED
Minimum documentation searched (classification system followed by classification symbols)
G02B

Documentation searched other than minimum documentation to the extent that such documents are included in the fields searched

Electronic data base consulted during the international search (name of data base and, where practicable, search terms used)
EPO-Internal

C. DOCUMENTS CONSIDERED TO BE RELEVANT

Category*	Citation of document, with indication, where appropriate, of the relevant passages	Relevant to claim No.
X	US 2003/053218 A1 (FUJIMOTO YASUSHI [JP] ET AL) 20 March 2003 (2003-03-20)	1-7,9
Y	figure 1	8
A	JP 2013 140393 A (OLYMPUS CORP) 18 July 2013 (2013-07-18)	1-10
Y	figure 4	
Y	US 6 069 744 A (KUSAKA KENICHI [JP] ET AL) 30 May 2000 (2000-05-30)	8
Y	figure 2	
A	US 2003/165021 A1 (KAWASAKI KENJI [JP]) 4 September 2003 (2003-09-04)	1-10
A	the whole document	
	----- -/--	

Further documents are listed in the continuation of Box C.

See patent family annex.

* Special categories of cited documents :

"A" document defining the general state of the art which is not considered to be of particular relevance

"E" earlier application or patent but published on or after the international filing date

"L" document which may throw doubts on priority claim(s) or which is cited to establish the publication date of another citation or other special reason (as specified)

"O" document referring to an oral disclosure, use, exhibition or other means

"P" document published prior to the international filing date but later than the priority date claimed

"T" later document published after the international filing date or priority date and not in conflict with the application but cited to understand the principle or theory underlying the invention

"X" document of particular relevance; the claimed invention cannot be considered novel or cannot be considered to involve an inventive step when the document is taken alone

"Y" document of particular relevance; the claimed invention cannot be considered to involve an inventive step when the document is combined with one or more other such documents, such combination being obvious to a person skilled in the art

"&" document member of the same patent family

Date of the actual completion of the international search 18 January 2016	Date of mailing of the international search report 25/01/2016
--	--

Name and mailing address of the ISA/ European Patent Office, P.B. 5818 Patentlaan 2 NL - 2280 HV Rijswijk Tel. (+31-70) 340-2040, Fax: (+31-70) 340-3016	Authorized officer Daffner, Michael
--	--

INTERNATIONAL SEARCH REPORT

International application No
PCT/EP2015/067352

C(Continuation). DOCUMENTS CONSIDERED TO BE RELEVANT		
Category*	Citation of document, with indication, where appropriate, of the relevant passages	Relevant to claim No.
X	US 2013/003187 A1 (WARTMANN ROLF [DE]) 3 January 2013 (2013-01-03) figures 1,2 -----	11-16
Y	EP 2 579 100 A2 (ASML HOLDING NV [NL]) 10 April 2013 (2013-04-10) figure 15 -----	18
X	US 6 016 226 A (ARISAWA KATSUYOSHI [JP]) 18 January 2000 (2000-01-18) figures 1-5 -----	17,19,20
Y		18
X	US 5 940 220 A (SUENAGA YUTAKA [JP] ET AL) 17 August 1999 (1999-08-17) figures 2,9 -----	21

INTERNATIONAL SEARCH REPORT

Information on patent family members

International application No PCT/EP2015/067352

Patent document cited in search report	Publication date	Patent family member(s)	Publication date
US 2003053218	A1	20-03-2003	JP 3985937 B2 03-10-2007
			JP 2003021786 A 24-01-2003
			US 2003053218 A1 20-03-2003

JP 2013140393	A	18-07-2013	JP 5596810 B2 24-09-2014
			JP 2013140393 A 18-07-2013
			JP 2013152484 A 08-08-2013

US 6069744	A	30-05-2000	JP H10288740 A 27-10-1998
			US 6069744 A 30-05-2000

US 2003165021	A1	04-09-2003	JP 3990126 B2 10-10-2007
			JP 2003066333 A 05-03-2003
			US 2003165021 A1 04-09-2003

US 2013003187	A1	03-01-2013	DE 102010014502 A1 13-10-2011
			US 2013003187 A1 03-01-2013
			WO 2011124300 A1 13-10-2011

EP 2579100	A2	10-04-2013	CN 103034069 A 10-04-2013
			EP 2579100 A2 10-04-2013
			JP 2013080921 A 02-05-2013
			KR 20130036156 A 11-04-2013
			SG 188737 A1 30-04-2013
			TW 201317717 A 01-05-2013
			US 2013083306 A1 04-04-2013

US 6016226	A	18-01-2000	JP 2975905 B2 10-11-1999
			JP H10253891 A 25-09-1998
			US 6016226 A 18-01-2000

US 5940220	A	17-08-1999	JP H10142510 A 29-05-1998
			US 5940220 A 17-08-1999

FURTHER INFORMATION CONTINUED FROM PCT/ISA/ 210

This International Searching Authority found multiple (groups of) inventions in this international application, as follows:

1. claims: 1-10

A lens triplet in an objective lens, wherein the surfaces are in substantial contact.

2. claims: 11-16

An inspection system with a group of three cemented lenses

3. claims: 17-20

A lithographic apparatus and a corresponding inspection apparatus

4. claim: 21

An objective lens with a post aperture triplet.
