

(12) **UK Patent Application** (19) **GB** (11) **2 279 372** (13) **A**

(43) Date of A Publication **04.01.1995**

(21) Application No **9412687.7**

(22) Date of Filing **23.06.1994**

(30) Priority Data

(31) **082684** (32) **24.06.1993** (33) **US**

(71) Applicant(s)

Kimberly-Clark Corporation

(Incorporated in USA - Delaware)

**401 North Lake Street, Neenah,
Wisconsin 54957-0349, United States of America**

(72) Inventor(s)

**Theodore Edwin Farrington Jr
Julia Smith Bahlman
Mark Alan Burazin
Fung-jou Chen
Kristin Ann Goerg
Michael Alan Hermans
Robert John Makolin
Michael John Rekoske**

(51) INT CL⁶

**D21F 11/14 , D21H 27/00 // D21F 5/18 11/04 , D21H
15/04**

(52) UK CL (Edition N)

**D1R RBF RGZ R151 R318 R461 R513 R514 R556 R614
R615 R634 R638
D2A ABA A200 A210 A308
D2W WE W102 W103 W309 W324 W326 W412
U1S S1122**

(56) Documents Cited

**GB 2006296 A GB 1533045 A EP 0568404 A1
US 4488932 A**

(58) Field of Search

**UK CL (Edition M) D1R RBF RFZ RGZ
INT CL⁵ A47K , D21F , D21H
Online databases:WPI**

(74) Agent and/or Address for Service

**Frank B Dehn & Co
Imperial House, 15-19 Kingsway, LONDON,
WC2B 6UZ, United Kingdom**

(54) **Soft tissue paper**

(57) Soft throughdried tissues are made without the use of a Yankee dryer. An aqueous suspension of papermaking fibres (11) are deposited on a forming fabric (13) to form a wet web. The web is transferred to a slower transfer fabric (17) and then to a throughdrying fabric (19), on which it is final dried by a throughdryer (21), before being transferred by carrier fabrics (25 and 26) to a reel (24). The typical Yankee functions of building machine direction and cross-machine direction stretch are replaced by a wet end rush transfer and the throughdrying fabric design, respectively. It is particularly advantageous to form the tissue with chemimechanically treated fibres in at least one layer e.g. by the use of a shaft disperger and by adding a softening agent. The resulting tissues have high bulk (about 6 cubic centimeters per gram or greater) and low stiffness.

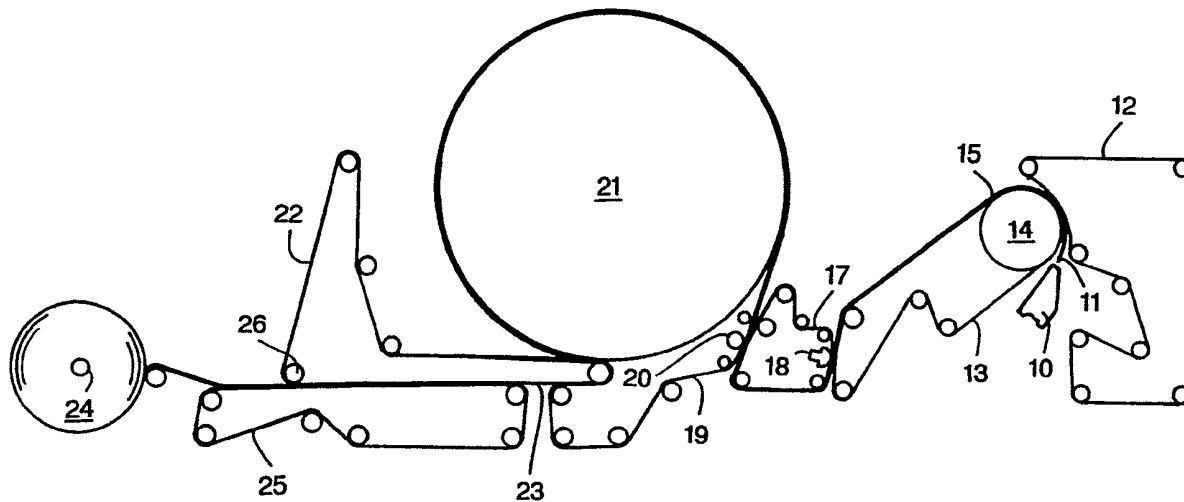

FIG. 1

GB 2 279 372 A

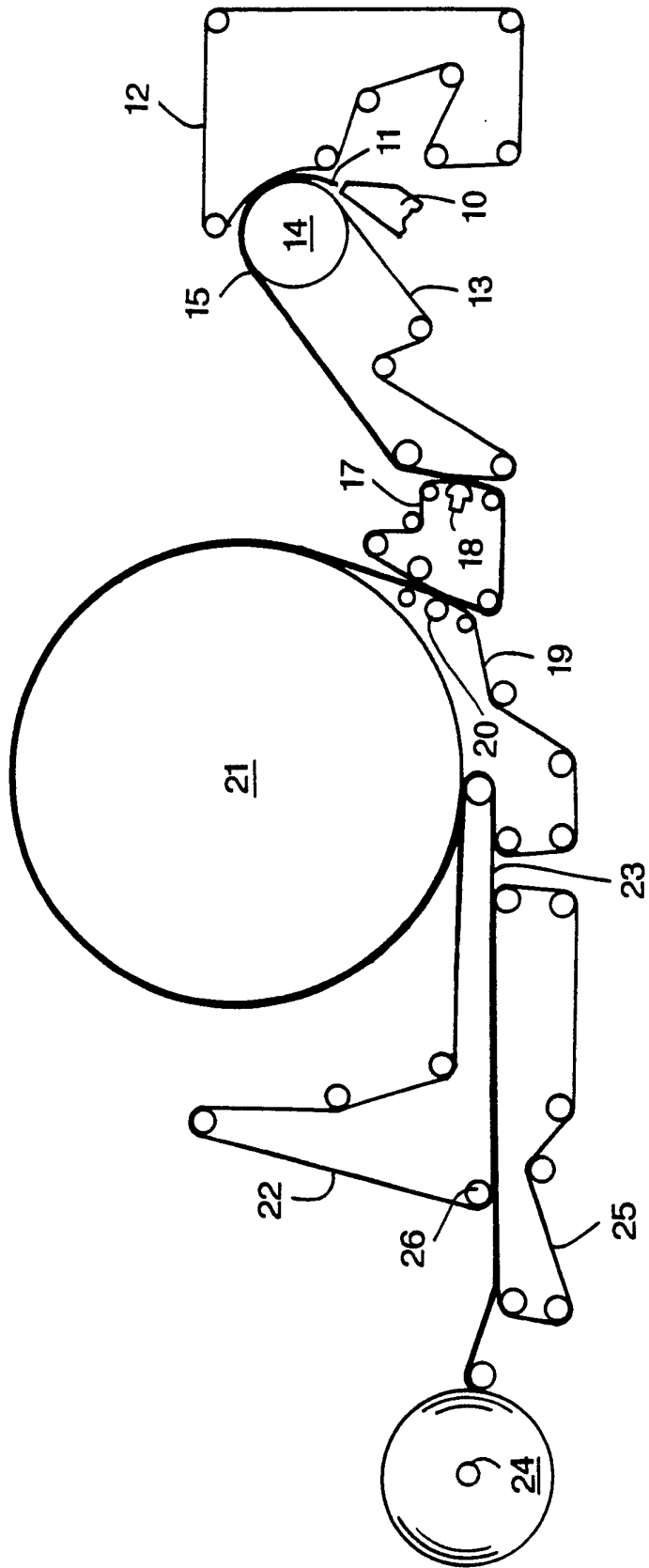

FIG. 1



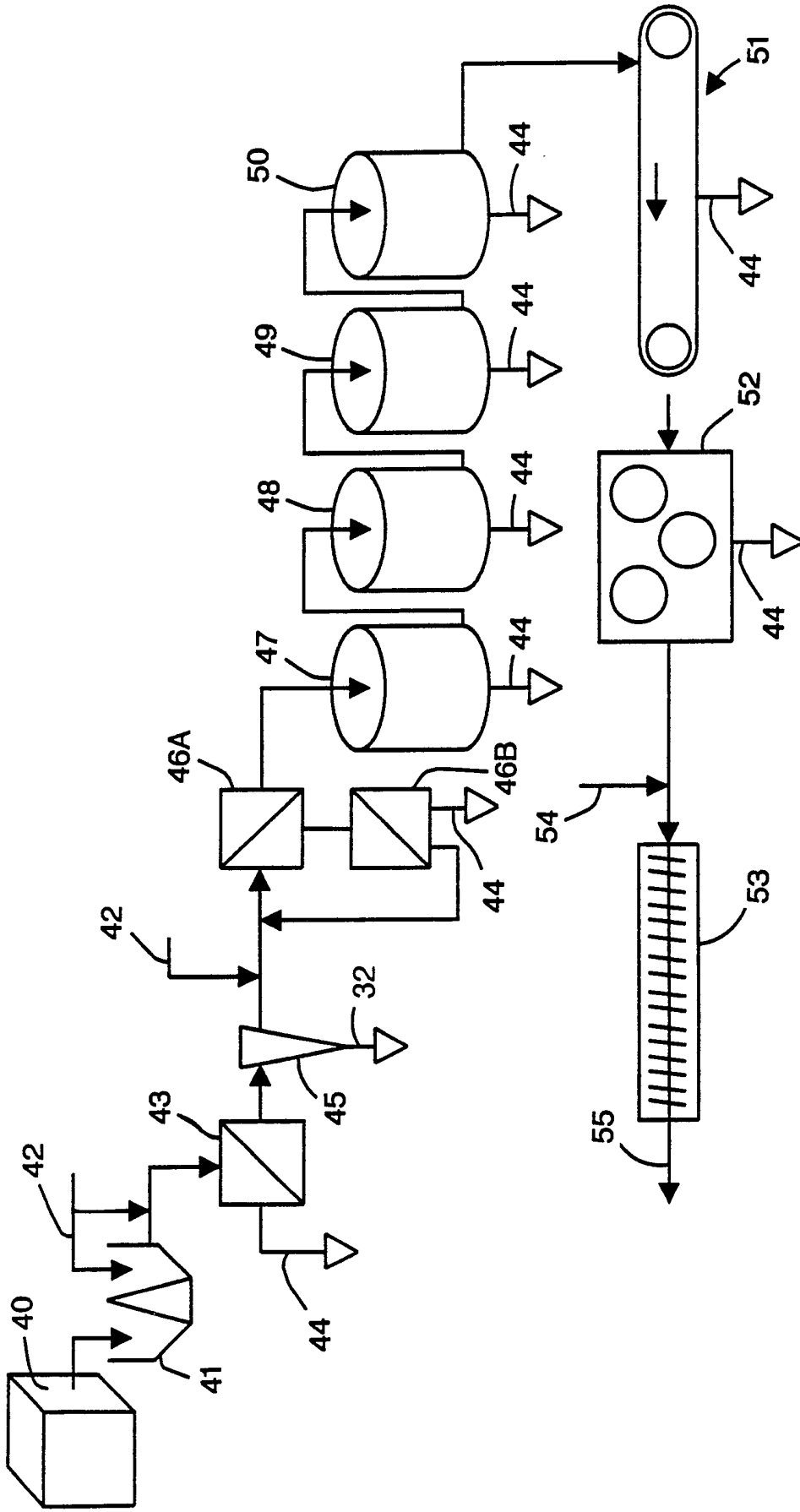

FIG. 2



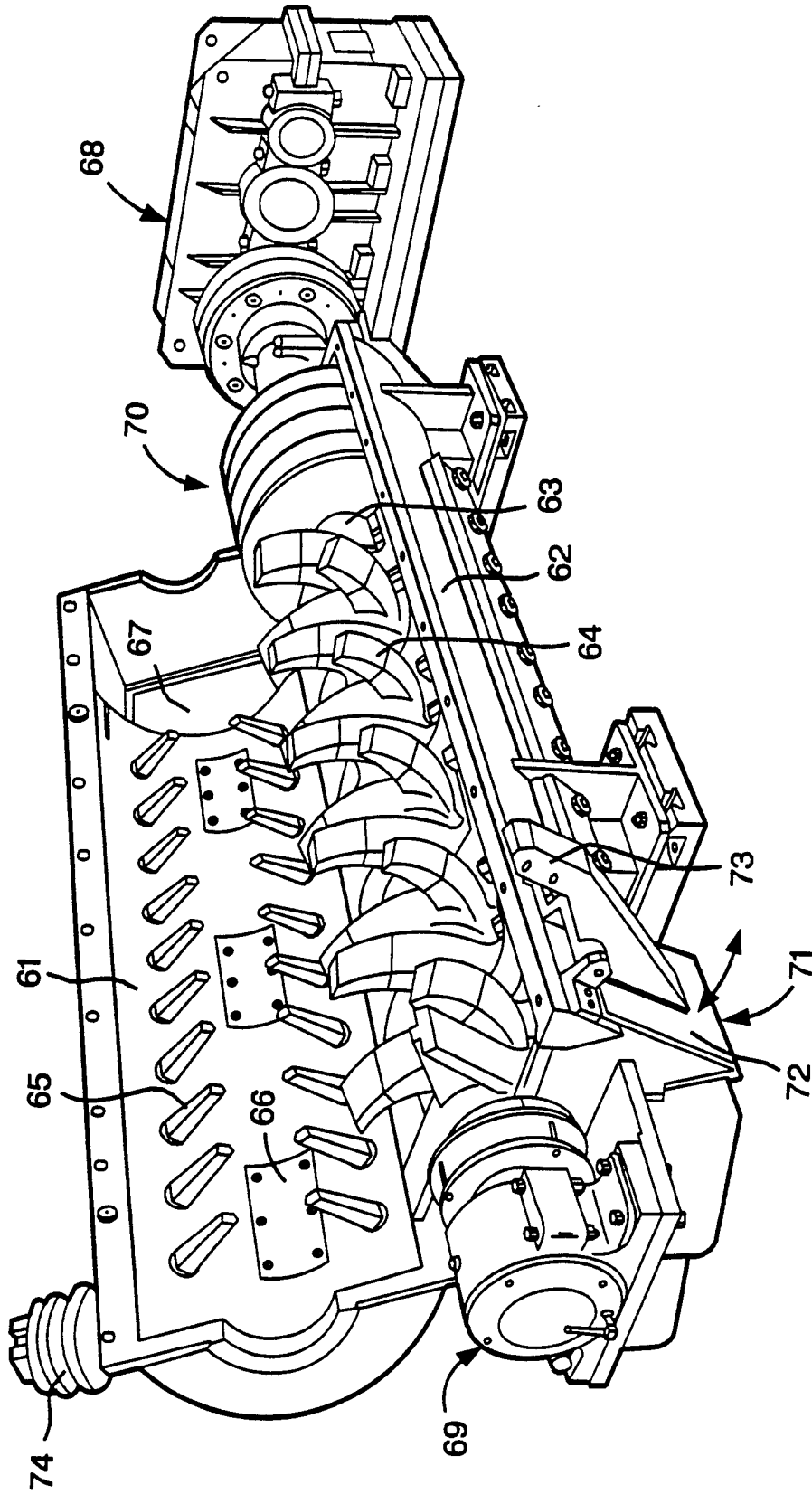

FIG. 3



4/10

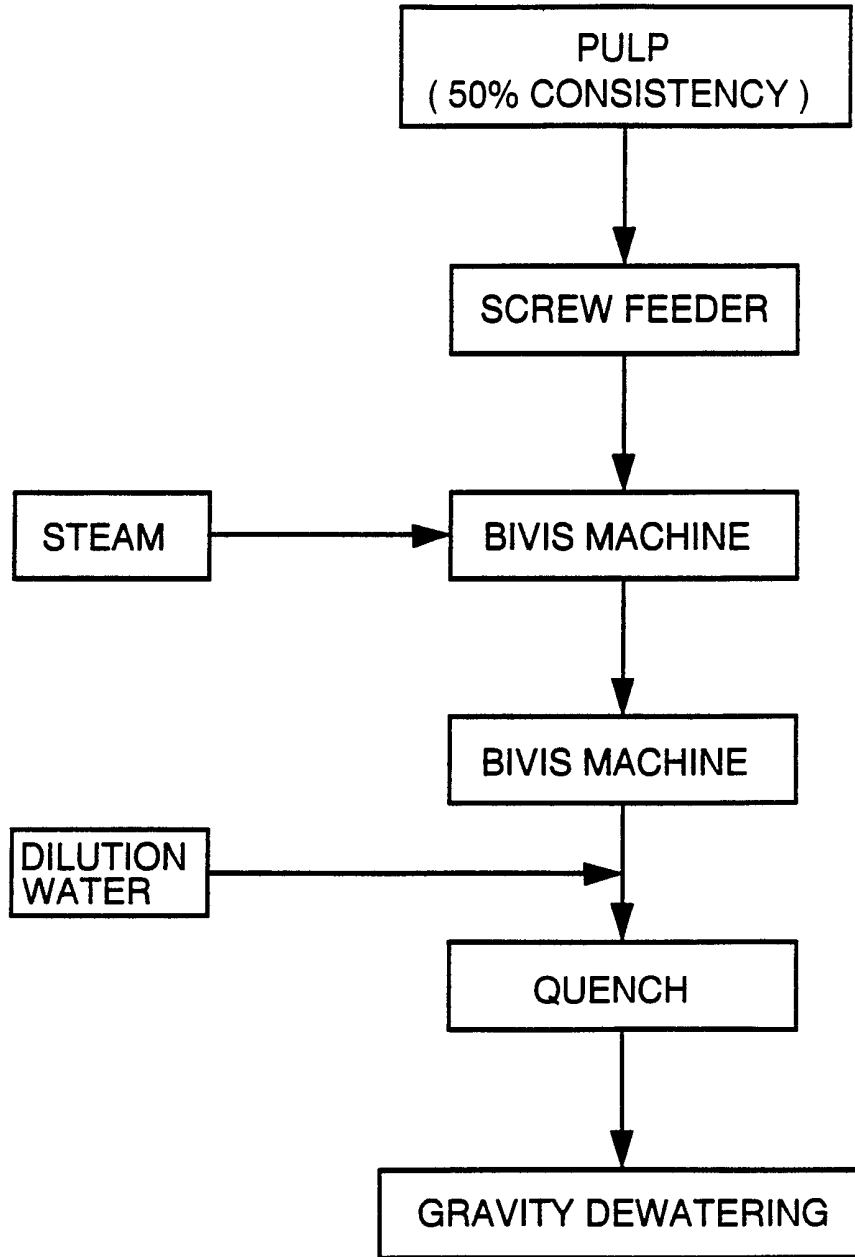

FIG. 4

5/10

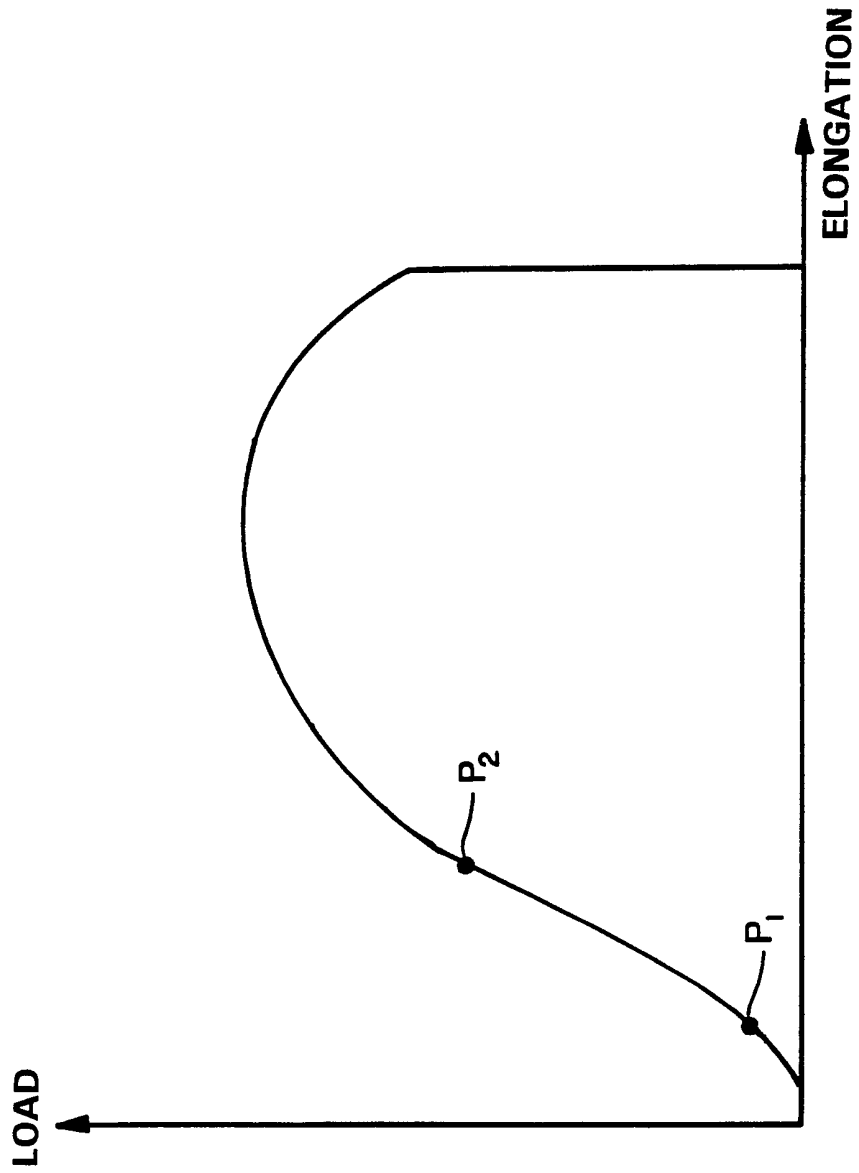

FIG. 5

6/10

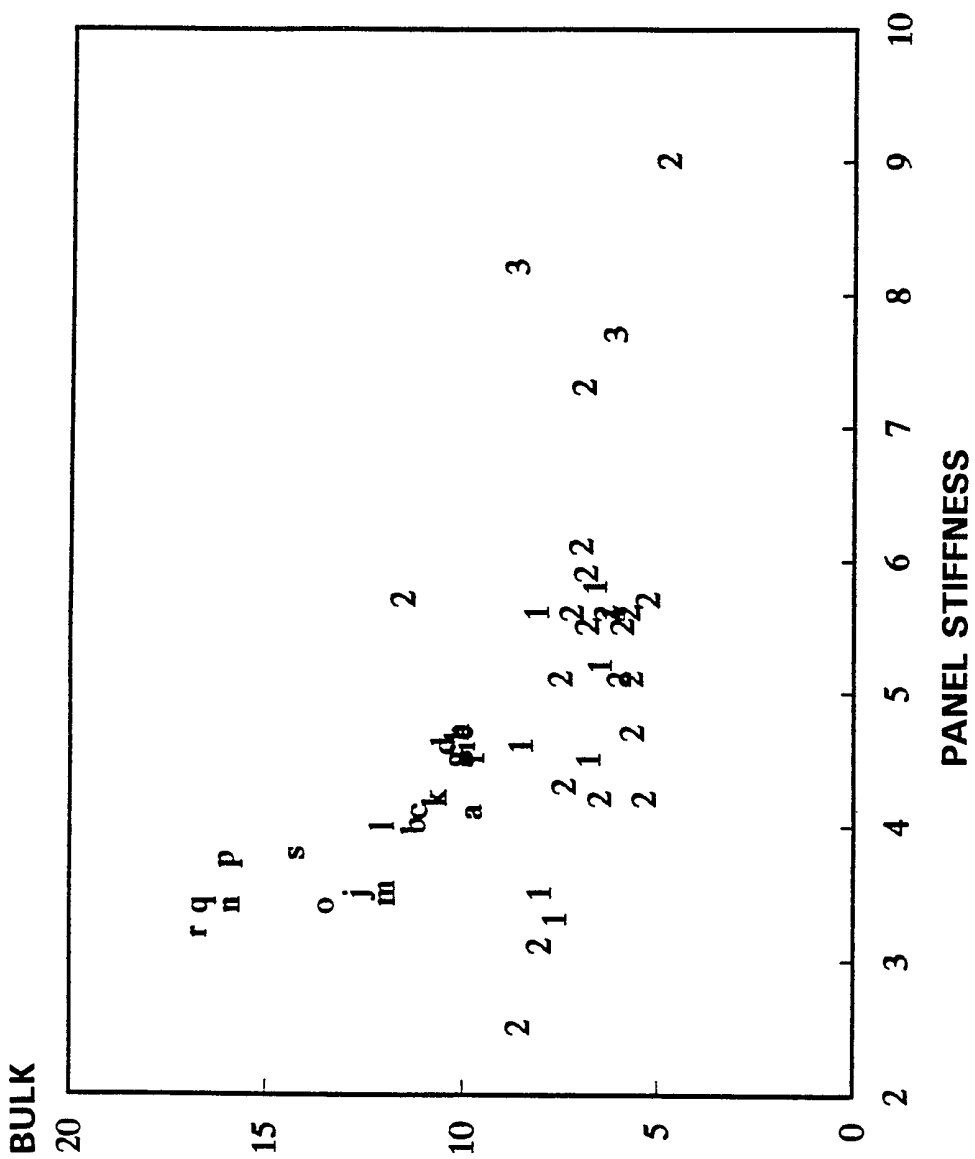

FIG. 6

8/10

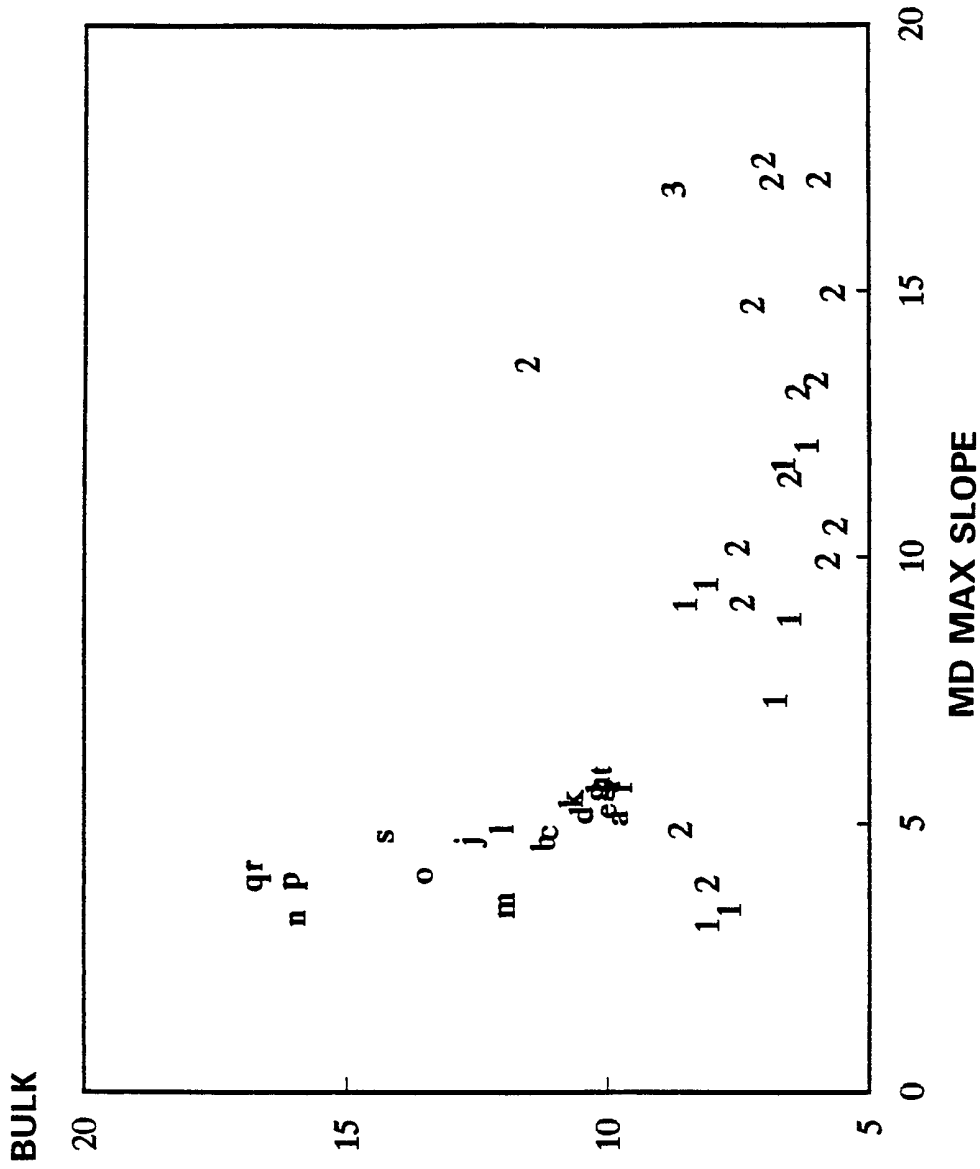

FIG. 8

10/10

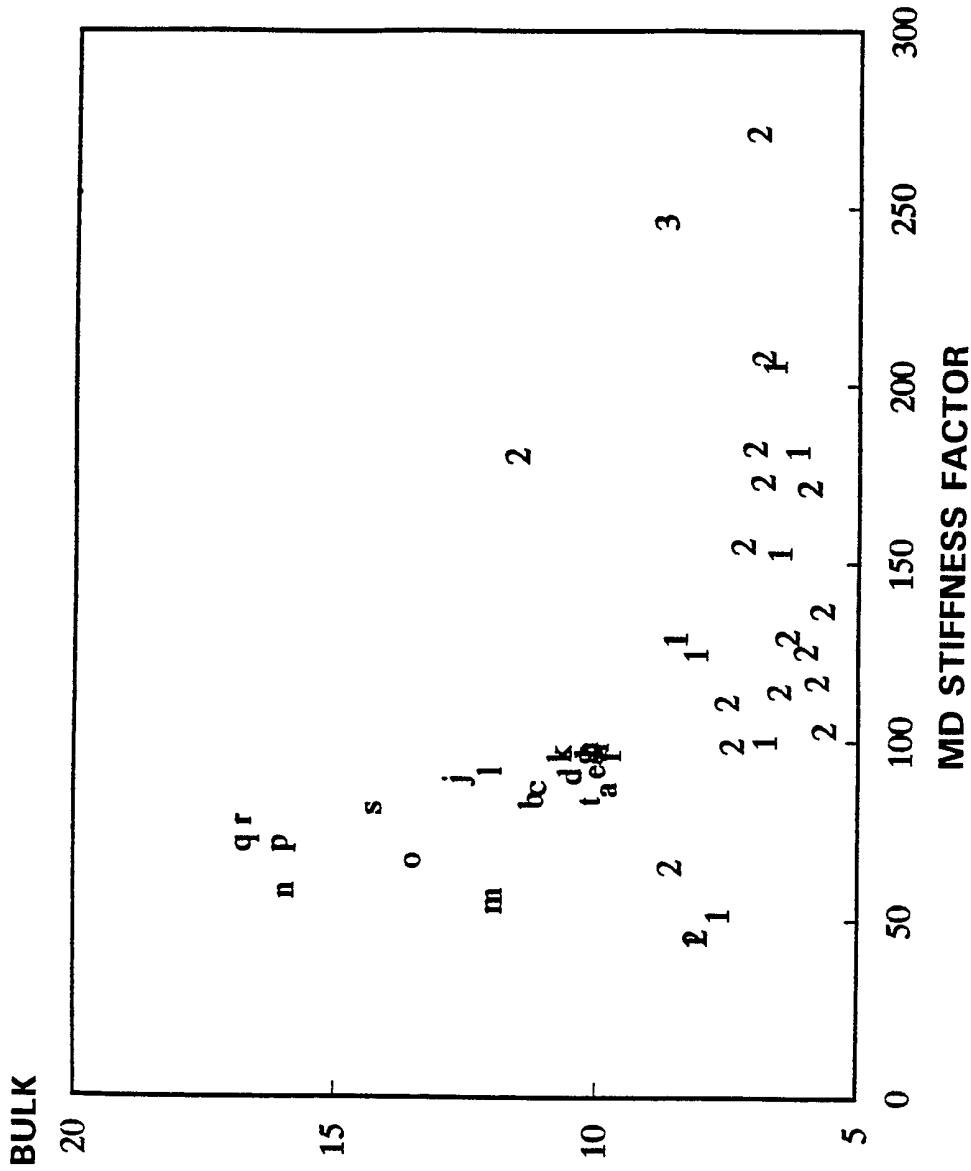

FIG. 10

SOFT TISSUE

5 In the manufacture of tissue products such as bath tissue, a wide variety of product characteristics must be given attention in order to provide a final product with the appropriate blend of attributes suitable for the product's intended purposes. Among these various attributes, improving softness has always been a major objective for premium products. Major components of softness include 10 stiffness and bulk (density), with lower stiffness and higher bulk (lower density) generally improving perceived softness.

15 Traditionally, tissue products have been made using a wet-pressing process in which a significant amount of water is removed from a wet laid web by pressing or squeezing water from the web prior to final drying. In particular, while supported by an absorbent papermaking felt, the web is squeezed between the felt and the surface of a rotating heated cylinder (Yankee dryer) using a pressure roll as the web is transferred to the surface of the Yankee dryer for final drying. The dried web is thereafter dislodged from the Yankee 20 dryer with a doctor blade (creping), which serves to partially debond the dried web by breaking many of the bonds previously formed during the wet-pressing stages of the process. Creping generally improves the softness of the web, albeit at the expense of a significant loss in strength.

25 More recently, throughdrying has become a more prevalent means of drying tissue webs. Throughdrying provides a relatively noncompressive method of removing water from the web by passing hot air through the web until it is dry. More specifically, a wet-laid web is transferred from the forming fabric to a coarse, highly 30 permeable throughdrying fabric and retained on the throughdrying fabric until it is dry. The resulting dried web is softer and bulkier than a wet-pressed uncreped dried sheet because fewer papermaking bonds are formed and because the web is less dense. Squeezing water from the wet web is eliminated, although subsequent

transfer of the web to a Yankee dryer for creping is still used to final dry and/or soften the resulting tissue.

5 While there is a processing incentive to eliminate the Yankee dryer and make an uncreped throughdried tissue, attempts to make throughdried tissue sheets without using a Yankee dryer (uncreped) have heretofore lacked adequate softness when compared to their creped counterparts. This is partially due to the inherently high stiffness and strength of an uncreped sheet, since without creping there is no mechanical debonding in the process. Because stiffness is a major component of softness, the use of uncreped throughdried sheets has been limited to applications and markets where high strength is paramount, such as for industrial wipers and towels, rather than for applications where softness is required, such as for bath tissue, premium household towels, and facial tissue in the consumer market.

20 It has now been discovered that tissues having properties particularly suitable for use as a bath tissue can be made using certain pretreated papermaking fibers in an appropriate process. A throughdrying tissue making process in which the tissue web is not adhered to a Yankee dryer and hence is uncreped is preferred. The resulting tissues of this invention are characterized by a unique combination of high bulk and low stiffness as compared to available creped bath tissue products and especially so as compared to prior uncreped throughdried products.

30 The stiffness of the products of this invention can be objectively represented by either the maximum slope of the machine direction (MD) load/elongation curve for the tissue (hereinafter referred to as the "MD Max Slope") or by the machine direction Stiffness Factor (hereinafter defined), which further takes into account the caliper of the tissue and the number of plies of the product. In accordance with this invention, by overcoming the inherently high stiffness of uncreped throughdried sheets, an acceptably soft tissue with high bulk and low stiffness can be produced. In addition, the products of this invention can have a high degree of stretch of about 10 percent or greater, which provides

in-use durability. Such soft, strong and stretchable tissue products with high bulk have heretofore never been made. While this invention is particularly applicable to bath tissue, it is also useful for other paper products where softness is a significant attribute, such as for facial tissue and household paper towels.

Hence in one aspect, the invention resides in a soft tissue having a Bulk (hereinafter defined) of about 9 cubic centimeters per gram or greater and an MD Max Slope of about 10 or less.

In another aspect, the invention resides in an a soft tissue comprising one or more uncreped throughdried plies and having a MD Max Slope of about 10 or less, preferably also having a Bulk of about 6 cubic centimeters per gram or greater.

In another aspect, the invention resides in a soft tissue having a Bulk of about 9 cubic centimeters per gram or greater and a MD Stiffness Factor of about 150 or less.

In another aspect, the invention resides in a soft tissue comprising one or more uncreped throughdried plies and having a MD Stiffness Factor of about 150 or less, preferably also having a Bulk of about 6 cubic centimeters per gram or greater.

In a further aspect, the invention resides in a method of making a soft tissue sheet comprising: (a) forming an aqueous suspension of papermaking fibers having a consistency of about 20 percent or greater; (b) mechanically working the aqueous suspension at a temperature of 140° F. or greater provided by an external heat source, such as steam, with a power input of about 1 horsepower-day per ton of dry fiber or greater to curl the fibers; (c) diluting the aqueous suspension of curled fibers to a consistency of about 0.5 percent or less and feeding the diluted suspension to a tissue-making headbox; (d) depositing the diluted aqueous suspension onto a forming fabric to form a wet web; (e) dewatering the wet web to a consistency of from about 20 to about 30 percent; (f) transferring the dewatered web from the forming fabric to a transfer fabric traveling at a speed of from about 10 to about 80 percent slower than the forming fabric; (g) transferring the web to a throughdrying fabric whereby the web is macroscopically rearranged to conform to the surface of the throughdrying fabric; and (h) throughdrying the web to final dryness.

The Bulk of the products of this invention is calculated as the quotient of the Caliper (hereinafter defined), expressed in microns, divided by the basis weight, expressed in grams per square meter. The resulting Bulk is expressed as cubic centimeters per gram. For the products of this invention, Bulks can be about 6 cubic centimeters per gram or greater, preferably about 9 cubic centimeters per gram or greater, suitably from about 9 to about 20 cubic centimeters per gram, and more specifically from about 10 to about 15 cubic centimeters per gram. The products of this invention derive the Bulks referred to above from the basesheet, which is the sheet produced by the tissue machine without post treatments such as embossing. Nevertheless, the basesheets of this invention can be embossed to produce even greater bulk or aesthetics, if desired, or they can remain unembossed. In addition, the basesheets of this invention can be calendered to improve smoothness or decrease the Bulk if desired or necessary to meet existing product specifications.

The MD Max Slope of the products of this invention can be about 10 or less, preferably about 5 or less, and suitably from about 3 to about 6. Determining the MD Max Slope will be hereinafter described in connection with Figure 6. The MD Max Slope is the maximum slope of the machine direction load/elongation curve for the tissue. The units for the MD Max Slope are kilograms per 3 inches (7.62 centimeters), but for convenience the MD Max Slope values are hereinafter referred to without the units.

The MD Stiffness Factor of the products of this invention can be about 150 or less, preferably about 100 or less, and suitably from about 50 to about 100. The MD Stiffness Factor is calculated by multiplying the MD Max Slope by the square root of the quotient of the Caliper divided by the number of plies. The units of the MD Stiffness Factor are (kilograms per 3 inches)-microns^{0.5}, but for simplicity the values of the MD Stiffness Factor are hereinafter referred to without the units.

The Caliper as used herein is the thickness of a single sheet, but measured as the thickness of a stack of ten sheets and dividing the ten sheet thickness by ten, where each sheet within the stack is placed with the same side up. Caliper is expressed in microns. It is measured in accordance with TAPPI test methods T402 "Standard

Conditioning and Testing Atmosphere For Paper, Board, Pulp Handsheets and Related Products" and T411 om-89 "Thickness (caliper) of Paper, Paperboard, and Combined Board" with Note 3 for stacked sheets. The micrometer used for carrying out T411 om-89 is a Bulk Micrometer (TMI
5 Model 49-72-00, Amityville, New York) having an anvil diameter of 4 1/16 inches (103.2 millimeters) and an anvil pressure of 220 grams/square inch (3.39 kiloPascals). After the Caliper is measured, the same ten sheets in the stack are used to determine the average basis weight of the sheets.

10 The products of this invention can be single-ply products or multi-ply products, such as two-ply, three-ply, four-ply or greater. One-ply products are advantageous because of their lower cost of manufacture, while multi-ply products are preferred by many
15 consumers. For multi-ply products it is not necessary that all plies of the product be the same, provided at least one ply is in accordance with this invention.

The basis weight of the products of this invention can be from about 5 to about 70 grams per square meter (gsm), preferably from about 10 to about 40 gsm, and more preferably from about 20 to about
20 30 gsm. For a single-ply bath tissue, a basis weight of about 25 gsm is preferred. For a two-ply tissue, a basis weight of about 20 gsm per ply is preferred. For a three-ply tissue, a basis weight of about 15 gsm per ply is preferred.

The tissues of this invention can also be characterized by a
25 relatively high degree of machine direction stretch. The amount of machine direction stretch can be about 10 percent or greater, suitably from about 15 to about 25 or 30 percent. Cross-machine direction (CD) stretch can be about 3 percent or greater, suitably from about 7 to about 10 percent. Machine direction stretch can be
30 imparted to the sheet upon transfer of the web from the forming fabric to the transfer fabric, and/or by transfer from a transfer fabric to another transfer fabric, and/or by transfer of the web from a transfer fabric to the throughdrying fabric. Cross-machine direction stretch is dominated by the throughdrying fabric design.

35 In order to be suitable for use as a bath tissue, the machine direction tensile strength is preferably about 600 grams per 3 inches (7.62 centimeters) of width or greater, more suitably from about 700

to about 1500 grams. Cross-machine direction tensile strengths are preferably about 300 grams per 3 inches (7.62 centimeters) of width or greater, more suitably from about 400 to about 600 grams.

5 The MD Tensile Strength, MD Tensile Stretch, CD Tensile Strength and CD Tensile Stretch are obtained according to TAPPI Test Method 494 OM-88 "Tensile Breaking Properties of Paper and Paperboard" using the following parameters: Crosshead speed is 10.0 in/min. (254 mm/min), full scale load is 10 lb (4,540 g), jaw span (the distance between the jaws, sometimes referred to as the gauge length) is 2.0 inches (50.8 mm), specimen width is 3 inches 10 (76.2 mm). The tensile testing machine is a Sintech, Model CITS-2000 (Systems Integration Technology Inc., Stoughton, MA; a division of MTS Systems Corporation, Research Triangle Park, NC).

Papermaking fibers useful for purposes of this invention include 15 any cellulosic fibers which are known to be useful for making paper, particularly those fibers useful for making relatively low density papers such as facial tissue, bath tissue, paper towels, dinner napkins and the like. Suitable fibers include virgin softwood and hardwood fibers, as well as secondary or recycled cellulosic fibers, 20 and mixtures thereof. Especially suitable hardwood fibers include eucalyptus and maple fibers. As used herein, "secondary fiber" means any cellulosic fiber which has previously been isolated from its original matrix via physical, chemical or mechanical means and, further, has been formed into a fiber web, dried to a moisture content of about 10 weight percent or less and subsequently 25 reisolated from its web matrix by some physical, chemical or mechanical means.

A key component in tissue softness is sheet stiffness or resistance to folding. Previous processes decrease stiffness via 30 creping, layering, patterned attachment to the Yankee dryer or some combination of these. Neither the first nor last process is possible in an uncreped throughdried process. Therefore, layering is expected to play a key role in reducing sheet stiffness at the required overall tensile strength. Ideally, the desired overall strength 35 would be carried in a very thin layer (for low stiffness) which has been treated to give very high strength or modulus (perhaps by refining or chemical action). The remaining layer(s) would comprise

fibers which have been treated to significantly reduce their strength (modulus). The key to achieving low stiffness at required overall strength then becomes treating or modifying the fibers in such a way as to maximize the difference in strength (modulus) of the layers.

5 An ideal modification for the weaker layer would simultaneously reduce tensile strength and increase bulk, as this would decrease modulus the greatest.

The modification methods to produce soft fibers for the relatively weak layers include mechanical modification, chemical
10 modification and combinations of mechanical modification and chemical modification. Mechanical modifications are achieved by methods which permanently deform the fibers through mechanical action. These methods introduce curl, kinks, and microcompressions into the fiber which decrease fiber-to-fiber bonding, decrease sheet tensile
15 strength, and increase sheet bulk, stretch, porosity and softness. Examples of suitable mechanical modification methods include flash drying, dry fiberizing and wet high-consistency curling. While any process or mechanical device which imparts fiber curl may increase sheet softness, those which produce more curl or a stiffer curl or a
20 more permanent curl upon exposure to water will increase sheet softness to a greater extent and are hence preferred. In addition, softness-enhancing chemicals can be added to mechanically-modified fibers either before or after mechanical modification to produce further increases in softness over the mechanical treatment or wet
25 end chemical addition alone. A preferred means for modifying the fibers for purposes of this invention is to pass the fibers through a shaft disperger, which is a wet high-consistency curling device which works the fibers (imparts high shear forces and a high degree of inter-fiber friction) at elevated temperature. Fibers which have
30 been passed through a shaft disperger (sometimes referred to herein as "disperging") are referred to as "disperged fibers". These fibers possess certain properties which make them particularly advantageous for making uncreped throughdried tissues because of their bulk building ability and their softness.

35 The consistency of the aqueous fiber suspension which is subjected to the disperging treatment must be high enough to provide significant fiber-to-fiber contact or working which will alter the

surface properties of the treated fibers. Specifically, the consistency can be at least about 20, more preferably from about 20 to about 60, and most preferably from about 30 to about 50 dry weight percent. The consistency will be primarily dictated by the kind of machine used to treat the fibers. For some rotating shaft dispergers, for example, there is a risk of plugging the machine at consistencies above about 40 dry weight percent. For other types of dispergers, such as the Bivis machine (commercially available from Clextral Company, Firminy Cedex, France), consistencies greater than 50 can be utilized without plugging. This device can be generally described as a pressurized twin screw shaft disperger, each shaft having several screw flights oriented in the direction of material flow followed by several flights oriented in the opposite direction to create back pressure. The screw flights are notched to permit the material to pass through the notches from one series of flights to another. It is desirable to utilize a consistency which is as high as possible for the particular machine used in order to maximize fiber-to-fiber contact.

The temperature of the fibrous suspension during disperging can be about 140°F. or greater, preferably about 150°F. or greater, more preferably about 210°F. or greater, and most preferably about 220°F. or greater. The upper limit on the temperature is dictated by whether or not the apparatus is pressurized, since the aqueous fibrous suspensions within an apparatus operating at atmospheric pressure cannot be heated beyond the boiling point of water. Interestingly, it is believed that the degree and permanency of the curl is greatly impacted by the amount of lignin in the fibers being subjected to the disperging process, with greater effects being attainable for fibers having higher lignin content. Hence high yield pulps having a high lignin content are particularly advantageous in that fibers previously considered not suitably soft can be transformed into suitably soft fibers. Such high yield pulps, listed in decreasing order of lignin content, are groundwood, thermomechanical pulp (TMP), chemimechanical pulp (CMP), and bleached chemithermomechanical pulp (BCTMP). These pulps have lignin contents of about 15 percent or greater, whereas chemical pulps (kraft and

sulfite) are low yield pulps having a lignin content of about 5 percent or less.

The amount of power applied to the fibrous suspension during dispersing also impacts the fiber properties. In general, increasing
5 the power input will increase the fiber curl. However, it has also been found that the fiber curl reaches a maximum upon reaching a power input of about 2 horsepower-days per ton (HPD/T) (1.6 kilowatt-days per tonne) of dry fiber in suspension. A preferred range of
10 power input is from about 1 to about 3 HPD/T (0.8 to about 2.5 kilowatt-days per tonne), more preferably about 2 HPD/T (1.6 kilowatt-days per tonne) or greater.

In working the fibers during dispersing, it is necessary that the fibers experience substantial fiber-to-fiber rubbing or shearing as well as rubbing or shearing contact with the surfaces of the
15 mechanical devices used to treat the fibers. Some compression, which means pressing the fibers into themselves, is also desirable to enhance or magnify the effect of the rubbing or shearing of the fibers. The measure of the appropriate amount of shearing and compression to be used lies in the end result, which is the
20 achievement of high bulk and low stiffness in the resulting tissue. A number of shaft dispersers or equivalent mechanical devices known in the papermaking industry can be used to achieve varying degrees of the desired results. Suitable shaft dispersers include, without
25 limitation, nonpressurized shaft dispersers and pressurized shaft dispersers such as the Bivis machines described above. Shaft dispersers can be characterized by their relatively high volume:internal surface area ratio and rely primarily on fiber-to-fiber contact to cause fiber modification. This is in contrast with
30 disc refiners or disc dispersers, which rely primarily on metal surface-to-fiber contact rather than fiber-to-fiber contact. While dispersing is a preferred method of modulus reduction for soft layer fibers, it is not intended that this invention be limited by the use of fibers treated in this manner. Mechanical or chemical means can be used to decrease the strength and modulus of these fibers and
35 employed along with a strength layer to directionally reduce sheet stiffness.

Softening agents, sometimes referred to as debonders, can be used to enhance the softness of the tissue product and such softening agents can be incorporated with the fibers before, during or after dispersing. Such agents can also be sprayed or printed onto the web after formation, while wet, or added to the wet end of the tissue machine prior to formation. Suitable agents include, without limitation, fatty acids, waxes, quaternary ammonium salts, dimethyl dihydrogenated tallow ammonium chloride, quaternary ammonium methyl sulfate, carboxylated polyethylene, cocamide diethanol amine, coco betaine, sodium lauryl sarcosinate, partly ethoxylated quaternary ammonium salt, distearyl dimethyl ammonium chloride, polysiloxanes and the like. Examples of suitable commercially available chemical softening agents include, without limitation, Berocell^(R.T.M.) 596 and 584 (quaternary ammonium compounds) manufactured by Eka Nobel Inc., Adogen^(R.T.M.) 442 (dimethyl dihydrogenated tallow ammonium chloride) manufactured by Sherex Chemical Company, Quasoft 203 (quaternary ammonium salt) manufactured by Quaker Chemical Company, and Arquad^(R.T.M.) 2HT-75 (di(hydrogenated tallow) dimethyl ammonium chloride) manufactured by Akzo Chemical Company. Suitable amounts of softening agents will vary greatly with the species selected and the desired results. Such amounts can be, without limitation, from about 0.05 to about 1 weight percent based on the weight of fiber, more specifically from about 0.25 to about 0.75 weight percent, and still more specifically about 0.5 weight percent.

Referring now to the tissue making process of this invention, the forming process and tackle can be conventional as is well known in the papermaking industry. Such formation processes include Fourdrinier, roof formers (such as suction breast roll), and gap formers (such as twin wire formers, crescent formers), etc. A twin wire former is preferred for higher speed operation. Forming wires or fabrics can also be conventional, the finer weaves with greater fiber support being preferred to produce a smoother sheet and the coarser weaves providing greater bulk. Headboxes used to deposit the fibers onto the forming fabric can be layered or nonlayered, although layered headboxes are advantageous because the properties of the tissue can be finely tuned by altering the composition of the various layers.

More specifically, for a single-ply product it is preferred to provide a three-layered tissue having dispersed fibers on both the "air side" of the tissue and on the "fabric side" of the tissue. (The "air side" refers to the side of the tissue not in contact with the fabric during drying, while the "fabric side" refers to the opposite side of the tissue which is in contact with the throughdryer fabric during drying.) The center of the tissue preferably comprises ordinary softwood fibers or secondary fibers, which have not been dispersed, to impart sufficient strength to the tissue. However, it is within the scope of this invention to include dispersed fibers in all layers. For a two-ply product, it is preferred to provide dispersed fibers on the fabric side of the tissue sheet and ply the two tissue sheets together such that the dispersed fiber layers become the outwardly facing surfaces of the product. Nevertheless, the dispersed fibers (virgin fibers or secondary fibers) can be present in any or all layers depending upon the sheet properties desired. In all cases the presence of dispersed fibers can increase Bulk and lower stiffness. The amount of dispersed fibers in any layer can be any amount from 1 to 100 weight percent, more specifically about 20 weight percent or greater, about 50 weight percent or greater, or about 80 weight percent or greater. It is preferred that the dispersed fibers be treated with a debonder as herein described to further enhance Bulk and lower stiffness.

In manufacturing the tissues of this invention, it is preferable to include a transfer fabric to improve the smoothness of the sheet and/or impart sufficient stretch. As used herein, "transfer fabric" is a fabric which is positioned between the forming section and the drying section of the web manufacturing process. The fabric can have a relatively smooth surface contour to impart smoothness to the web, yet must have enough texture to grab the web and maintain contact during a rush transfer. It is preferred that the transfer of the web from the forming fabric to the transfer fabric be carried out with a "fixed-gap" transfer or a "kiss" transfer in which the web is not substantially compressed between the two fabrics in order to preserve the caliper or bulk of the tissue and/or minimize fabric wear.

Transfer fabrics include single-layer, multi-layer or composite permeable structures. Preferred fabrics have at least one of the

following characteristics: (1) On the side of the transfer fabric that is in contact with the wet web (the top side), the number of machine direction (MD) strands per inch (mesh) is from 10 to 200 (4 to 80 per centimeter) and the number of cross-machine direction (CD) strands per inch (count) is also from 10 to 200. The strand diameter is typically smaller than 0.050 inch (1.3 millimeter); and (2) on the top side, the distance between the highest point of the MD knuckle and the highest point of the CD knuckle is from about 0.001 to about 0.02 or 0.03 inch (0.025 to about 0.5 or 0.75 millimeter). In between these two levels, there can be knuckles formed either by MD or CD strands that give the topography a 3-dimensional characteristic. Specific suitable transfer fabrics include, by way of example, those made by Asten Forming Fabrics, Inc., Appleton, Wisconsin, and designated as numbers 934, 937, 939 and 959 and Albany 94M manufactured by Albany International, Appleton Wire Division, Appleton, Wisconsin.

In order to provide stretch to the tissue, a speed differential is provided between fabrics at one or more points of transfer of the wet web. The speed difference between the forming fabric and the transfer fabric can be from about 5 to about 75 percent or greater, preferably from about 10 to about 35 percent, and more preferably from about 15 to about 25 percent, based on the speed of the slower transfer fabric. The optimum speed differential will depend on a variety of factors, including the particular type of product being made. As previously mentioned, the increase in stretch imparted to the web is proportional to the speed differential. For a single-ply uncreped throughdried bath tissue having a basis weight of about 25 grams per square meter, for example, a speed differential of from about 20 to about 25 percent between the forming fabric and a sole transfer fabric produces a stretch in the final product of from about 15 to about 25 percent. The stretch can be imparted to the web using a single differential speed transfer or two or more differential speed transfers of the wet web prior to drying. Hence there can be one or more transfer fabrics. The amount of stretch imparted to the web can hence be divided among one, two, three or more differential speed transfers. The web is transferred to the last fabric (the throughdrying fabric) for final drying preferably with the assistance

of vacuum to ensure macroscopic rearrangement of the web to give the desired Bulk and appearance. The use of separate transfer and throughdrying fabrics offers a significant improvement over the prior art since it allows the two fabrics to be designed specifically to address key product requirements independently. For example, the transfer fabrics are generally optimized to allow efficient conversion of high rush transfer levels to high MD stretch and to improve sheet smoothness while throughdrying fabrics are designed to deliver bulk and CD stretch. It is therefore useful to have quite fine and relatively planar transfer fabrics and throughdrying fabrics which are quite coarse and three dimensional in the optimized configuration. The result is that a relatively smooth sheet leaves the transfer section and then is macroscopically rearranged (with vacuum assist) to give the high bulk, high CD stretch surface topology of the throughdrying fabric. No visible (at least not macroscopically visible) trace of the transfer fabric remains in the finished product. Sheet topology is completely changed from transfer to throughdrying fabric and fibers are macroscopically rearranged, including significant fiber-fiber movement.

The drying process can be any noncompressive drying method which tends to preserve the bulk or thickness of the wet web including, without limitation, throughdrying, infra-red radiation, microwave drying, etc. Because of its commercial availability and practicality, throughdrying is well-known and is a preferred means for noncompressively drying the web for purposes of this invention. Suitable throughdrying fabrics include, without limitation, Asten 920A and 937A and Velostar P800 and 103A. The web is preferably dried to final dryness on the throughdrying fabric, without being pressed against the surface of a Yankee dryer, and without subsequent creping. This provides a product of relatively uniform density as compared to products made by a process in which the web was pressed against a Yankee while still wet and supported by the throughdrying fabric or by another fabric, or as compared to spot-bonded airlaid products. Although the final product appearance and bulk are dominated by the throughdrying fabric design, the machine direction stretch in the web is primarily provided by the transfer fabric, thus giving the method of this invention greater process flexibility.

Embodiments of the present invention will now be described, by way of example only, with reference to the accompanying drawings, in which:

Figure 1 is a schematic process flow diagram illustrating a method of making uncreped throughdried sheets in accordance with this invention.

Figure 2 is a schematic process flow diagram of a method of treating fibers in accordance with this invention using a shaft disperger to work the fibers.

Figure 3 is a cut-away perspective view of the shaft disperger of Figure 2.

Figure 4 is a schematic process flow diagram of an alternative method in accordance with this invention using a pair of Bivis shaft dispergers in series.

Figure 5 is a generalized plot of a load/elongation curve for tissue, illustrating the determination of the MD Max Slope.

Figure 6 is a plot of Bulk versus Panel Stiffness (stiffness as determined by a trained sensory panel) for the bath tissues made in accordance with this invention and commercially available creped bath tissues, illustrating the high level of bulk and low stiffness exhibited by the products of this invention.

Figure 7 is a plot of Panel Stiffness versus MD Max Slope for the bath tissues made in accordance with this invention and commercially available bath tissues, illustrating the correlation of Panel Stiffness with the MD Max Slope.

Figure 8 is a plot of Bulk versus MD Max Slope for the bath tissues made in accordance with this invention and commercially available bath tissues, further illustrating the high Bulk and low stiffness exhibited by the products of this invention.

Figure 9 is a plot similar to that of Figure 8, but for Panel Stiffness versus MD Stiffness Factor, illustrating the correlation of Panel Stiffness and the MD Stiffness Factor.

Figure 10 is a plot similar to that of Figure 9, but for Bulk versus the MD Stiffness Factor, further illustrating the high Bulk and low stiffness of the products of this invention.

Figure 1 illustrates a means for carrying out the method of this invention. (For simplicity, the various tensioning rolls schematically used to define the several fabric runs are shown but not numbered. It will be appreciated that variations from the apparatus and method illustrated in Figure 1 can be made without departing from the scope of the invention.) Shown is a twin wire former having a layered papermaking headbox 10 which injects or deposits a stream 11 of an aqueous suspension of papermaking fibers onto the forming fabric 13 which serves to support and carry the newly-formed wet web downstream in the process as the web is partially dewatered to a consistency of about 10 dry weight percent. Additional dewatering of the wet web can be carried out, such as by vacuum suction, while the wet web is supported by the forming fabric.

The wet web is then transferred from the forming fabric to a transfer fabric 17 traveling at a slower speed than the forming fabric in order to impart increased stretch into the web. Transfer is preferably carried out with the assistance of a vacuum shoe 18 and a fixed gap or space between the forming fabric and the transfer fabric or a kiss transfer to avoid compression of the wet web.

The web is then transferred from the transfer fabric to the throughdrying fabric 19 with the aid of a vacuum transfer roll 20 or a vacuum transfer shoe, optionally again using a fixed gap transfer as previously described. The throughdrying fabric can be traveling at about the same speed or a different speed relative to the transfer fabric. If desired, the throughdrying fabric can be run at a slower speed to further enhance stretch. Transfer is preferably carried out with vacuum assistance to ensure deformation of the sheet to conform to the throughdrying fabric, thus yielding desired Bulk and appearance.

The level of vacuum used for the web transfers can be from about 3 to about 15 inches of mercury (75 to about 380 millimeters of mercury), preferably about 5 inches (125 millimeters) of mercury. The vacuum shoe (negative pressure) can be supplemented or replaced by the use of positive pressure from the opposite side of the web to

blow the web onto the next fabric in addition to or as a replacement for sucking it onto the next fabric with vacuum. Also, a vacuum roll or rolls can be used to replace the vacuum shoe(s).

5 While supported by the throughdrying fabric, the web is final dried to a consistency of about 94 percent or greater by the throughdryer 21 and thereafter transferred to a carrier fabric 22. The dried basesheet 23 is transported to the reel 24 using carrier fabric 22 and an optional carrier fabric 25. An optional pressurized turning roll 26 can be used to facilitate transfer of the web from
10 carrier fabric 22 to fabric 25. Suitable carrier fabrics for this purpose are Albany International 84M or 94M and Asten 959 or 937, all of which are relatively smooth fabrics having a fine pattern. Although not shown, reel calendering or subsequent off-line calendering can be used to improve the smoothness and softness of the
15 basesheet.

Figure 2 is a block flow diagram illustrating overall process steps for treating secondary papermaking fibers in preparation for disperging. (For virgin fibers, the fibers can be slurried with water to the desired consistency and introduced directly into the
20 disperger). Shown is the paper furnish 40 to be treated being fed to a high consistency pulper 41 (Model ST6C-W, Bird Escher Wyss, Mansfield, MA) with the addition of dilution water 42 to reach a consistency of about 15 percent. Prior to being pumped out of the pulper, the stock is diluted to a consistency of about 6 percent.
25 The pulped fibers are fed to a scalping screen 43 (Fiberizer Model FT-E, Bird Escher Wyss) with additional dilution water in order to remove large contaminants. The input consistency to the scalping screen is about 4 percent. The rejects from the scalping screen are directed to waste disposal 44. The accepts from the scalping screen
30 are fed to a high density cleaner 45 (Cyclone Model 7 inch size, Bird Escher Wyss) in order to remove heavy contaminants which have escaped the scalping screen. The rejects from the high density cleaner are directed to waste disposal. The accepts from the high density cleaner are fed to a fine screen 46A (Centrisorter Model 200, Bird
35 Escher Wyss) to further remove smaller contaminants. Dilution water is added to the fine screen feed stream to achieve a feed consistency of about 2 percent. Rejects from the fine screen are directed to a

second fine screen 46B (Axiguard, Model 1, Bird Escher Wyss) to remove additional contaminants. The accepts are recycled to the feed stream to the fine screen 46A and the rejects are directed to waste disposal. The accepts from the fine screen, with the addition of dilution water to reach a consistency of about 1 percent, are then passed to a series of four flotation cells 47, 48, 49 and 50 (Aerator Model CF1, Bird Escher Wyss) to remove ink particles and stickies. Rejects from each of the flotation cells are directed to waste disposal. The accepts from the last flotation cell are fed to a washer 51 (Double Nip Thickener Model 100, Black Clawson Co., Middletown, OH) to remove very small ink particles and increase the consistency to about 10 percent. Rejects from the washer are directed to waste disposal. The accepts from the washer are fed to a belt press 52 (Arus-Andritz Belt Filter Press Model CPF 20 inches, Andritz-Ruthner Inc., Arlington, TX) to reduce the water content to about 30 percent. Rejects from the belt press are directed to waste disposal. The resulting partially dewatered fibrous material is then fed to a shaft disperger 53 (GR 11, Ing. S. Maule & C. S.p.A., Torino, Italy), described in detail in Figure 3, in order to work the fibers to improve their properties in accordance with this invention. Steam 54 is added to the disperger feed stream to elevate the temperature of the feed material. The resulting treated fibers 55 can be directly used as feedstock for papermaking or otherwise further treated as desired.

Figure 3 is a cut-away perspective view of a preferred apparatus for treating fibers in accordance with this invention as illustrated in Figure 2. The particular apparatus is a shaft disperger, Type GR II, manufactured by Ing. S. Maule & C. S.p.A., Torino, Italy. Shown are an upper cylindrical housing 61 and a lower cylindrical housing 62 which, when closed, enclose a rotating shaft 63 having a multiplicity of arms 64. The upper housing contains two rows of knurled fingers 65 and three inspection ports 66. At one end of the upper housing is an inlet port 67. At the inlet end of the rotating shaft is driver motor 68 for turning the shaft. At the outlet end of the rotating shaft is a bearing housing 69 which supports the rotating shaft. The inlet end of the rotating shaft contains a screw feed section 70 which is positioned directly below the inlet and

5 serves to urge the feed material through the disperger. The outlet 71 of the disperger comprises a hinged flap 72 having a lever 73 which, when the disperger is closed up, is engaged by hydraulic air bags 74 mounted on the upper housing. The air bags provide controllable resistance to the rotation of the hinged flap and hence provide a means of controlling the back pressure within the disperger. Increasing the back pressure increases the degree to which the fibers are worked. During operation, the knurled fingers interdigitate with the arms of the rotating shaft to work the feed material therebetween.

10 Figure 4 is a block flow diagram of an alternative process of this invention utilizing a pair of twin shaft dispergers (Bivis machines). As illustrated, papermaking pulp, at a consistency of about 50 percent, is fed to a screw feeder. The screw feeder meters the feedstock to the first of two Bivis machines in series. Each Bivis machine has three compression/expansion zones. Steam is injected into the first Bivis machine to raise the temperature of the fibers to about 212°F. (100°C.). The worked pulp is transferred to the second Bivis machine operating at the same conditions as the first Bivis machine. The worked pulp from the second machine can be quenched by dropping it into a cold water bath and thereafter dewatering to a suitable consistency.

20 Figures 5-10 will be discussed below in connection with the Examples.

25

Examples

Examples 1-20. To illustrate the invention, a number of uncreped throughdried tissues were produced using the method substantially as illustrated in Figure 1. More specifically, Examples 1-19 were all three-layered, single-ply bath tissues in which the outer layers comprised disperged, debonded eucalyptus fibers and the center layer comprised refined northern softwood kraft fibers. Example 20 was a two-ply bath tissue, each ply being layered as described for the previous examples. Cenebra eucalyptus fibers were pulped for 15 minutes at 10% consistency and dewatered to 30% consistency. The pulp was then fed to a Maule shaft disperger as illustrated in Figure 3. The disperger was operated at 160°F.

35

(70°C.) with a power input of 2.2 HPD/T (1.8 kilowatt-days per tonne). Subsequent to dispersing, a softening agent (Berozell 584) was added to the pulp in the amount of 10 lb. Berozell per ton dry fiber (0.5 wight percent).

5 Prior to formation, the softwood fibers were pulped for 30 minutes at 2.5 percent consistency, while the dispersed, debonded eucalyptus fibers were diluted to 2 percent consistency. The overall layered sheet weight was split 37.5%/25%/37.5% among the dispersed eucalyptus/refined softwood/dispersed eucalyptus layers. The center
10 layer was refined to levels required to achieve target strength values, while the outer layers provided softness and bulk.

These examples employed a four-layer Beloit Concept III headbox. The refined northern softwood kraft stock was used in the two center layers of the headbox to produce a single center layer for the three-
15 layered product described. Turbulence generating inserts recessed about three inches (75 millimeters) from the slice and layer dividers extending about six inches (150 millimeters) beyond the slice were employed. Flexible lip extensions extending about six inches (150 millimeters) beyond the slice were also used, as taught in U.S.
20 Patent No. 5,129,988 issued July 14, 1992 to Farrington, Jr. entitled "Extended Flexible Headbox Slice With Parallel Flexible Lip Extensions and Extended Internal Dividers", which is herein incorporated by reference. The net slice opening was about 0.9 inch (23 millimeters) and water flows in all four headbox layers were
25 comparable. The consistency of the stock fed to the headbox was about 0.09 weight percent.

The resulting three-layered sheet was formed on a twin-wire, suction form roll, former with forming fabrics (12 and 13 in Figure 1) being Asten 866 and Asten 856A fabrics respectively of about 64.5%
30 and 61% void volume respectively. Speed of the forming fabric was 12.1 meters per second. The newly-formed web was then dewatered to a consistency of about 20-27% using vacuum suction from below the forming fabric before being transferred to the transfer fabric which was traveling at 9.7 meters per second (25% rush transfer). Transfer
35 fabrics employed included an Asten 934 and an Albany 94M. A vacuum shoe pulling about 6-15 inches (150-380 millimeters) of mercury vacuum was used to transfer the web to the transfer fabric.

The web was then transferred to a throughdrying fabric traveling at a speed of about 9.7 meters per second. Velostar 800 and Asten 934 throughdrying fabrics were used. The web was carried over a Honeycomb throughdryer operating at a temperature of about 350°F. (175°C.) and dried to a final dryness of about 94-98% consistency.

Table 1 gives more detailed descriptions of the process condition as well as resulting tissue properties for examples 1-20, illustrating this invention. As used in Tables 1 and 2 below, the column headings have the following meanings: "TAD Fabric" means throughdrying fabric (the designation "W" or "S" for the throughdrying fabric refers to which side of the fabric is presented to the web. "W" denotes the side dominated by warp knuckles and "S" denotes the side dominated by shute knuckles.); "#1 Trans Vac" is the vacuum used to transfer the web from the forming fabric to the transfer fabric, expressed in millimeters of mercury; "#2 Trans Vac" is the vacuum used to transfer the web from the transfer fabric to the throughdrying fabric, expressed in millimeters of mercury; "Cons @#1 Trans" is the consistency of the web at the point of transfer from the forming fabric to the transfer fabric, expressed as percent solids; "Cons @#2 Trans" is the consistency of the web at the point of transfer from the transfer fabric to the throughdrying fabric, expressed as percent solids; "MD Tensile Strength" is the machine direction tensile strength, expressed in grams per 3 inches (7.62 centimeters) of sample width; "MD Tensile Stretch" is the machine direction stretch, expressed as percent elongation at sample failure; "MD Max Slope" is as defined above, expressed as kilograms per 3 inches (7.62 centimeters) of sample width; "CD Tensile Strength" is the cross-machine tensile strength, expressed as grams per 3 inches (7.62 centimeters) of sample width; "CD Tensile Stretch" is the cross-machine direction stretch, expressed as percent elongation at sample failure; "GMT" is the geometric mean tensile strength, expressed as grams per 3 inches (7.62 centimeters) of sample width; "Basis Wt" is the finished basis weight, expressed as grams per square meter; "Caliper" is the 10 sheet caliper, divided by ten, as previously described, expressed in microns; "Bulk" is the Bulk as defined above, expressed in cubic centimeters per gram; "Panel Stiff" is the stiffness of the sheet as determined by a trained sensory

panel feeling for the relative sharpness of the folds when a sheet is taken up into the hand, expressed as a number on a scale of from 1 to 14, with higher numbers meaning greater stiffness (commercial bath tissues typically range from about 3 to about 8); and "MD Stiff Factor" is the Machine Direction Stiffness Factor as defined above, expressed as (kilograms per 3 inches)-microns^{0.5}.

TABLE 1

EXAMPLE	TRANSFER FABRIC	TAD FABRIC	#1 TRANS VAC	#2 TRANS VAC	CONS @#1 TRANS	CONS @#2 TRANS	MD TENSILE STRENGTH	MD TENSILE STRETCH	MD MAX SLOPE
1	ALBANY 94M W	VELOSTAR	380	200	20-22	22-24	775	19.2	5.087
2	ASTEN 934 W	ASTEN 934	380	100	20-22	27-29	721	19.3	4.636
3	ASTEN 934 W	ASTEN 934	150	100	20-22	22-24	712	18.9	4.815
4	ALBANY 94M S	VELOSTAR	150	200	20-22	27-29	799	19.2	5.149
5	ALBANY 94M S	VELOSTAR	380	100	20-22	27-29	834	22.0	5.223
6	ALBANY 94M S	ASTEN 934	380	100	20-22	27-29	897	20.2	5.621
7	ALBANY 94M S	VELOSTAR	150	100	20-22	22-24	815	19.1	5.543
8	ALBANY 94M W	VELOSTAR	150	100	25-27	27-29	843	21.7	5.698
9	ALBANY 94M W	VELOSTAR	380	100	20-22	27-29	867	20.0	5.696
10	ASTEN 934 W	ASTEN 934	380	200	20-22	22-24	721	20.6	4.709
11	ALBANY 94M S	VELOSTAR	380	200	25-27	27-29	819	20.2	5.441
12	ASTEN 934 W	ASTEN 934	150	200	20-22	27-29	709	20.2	4.913
13	ALBANY 94M W	VELOSTAR	380	200	25-27	27-29	531	20.1	3.496
14	ASTEN 934 W	ASTEN 934	380	200	25-27	27-29	472	19.5	3.244
15	ALBANY 94M S	VELOSTAR	380	200	25-27	27-29	631	21.4	4.036
16	ASTEN 937 S	ASTEN 934	380	200	25-27	27-29	535	20.9	3.933
17	VELOSTAR 800W	ASTEN 934	380	200	25-27	27-29	427	16.3	3.901
18	ASTEN 934 S	ASTEN 934	380	200	25-27	27-29	530	21.3	4.206
19	ALBANY 94M S	VELOSTAR	380	200	25-27	27-29	600	20.8	4.754
20	ALBANY 94M S	VELOSTAR	380	200	25-27	27-29	708	18.7	5.970

TABLE 1 (CONTINUED)

	CD TENSILE STRENGTH	CD TENSILE STRETCH	GMT	BASIS WT	CALIPER	BULK	PANEL STIFF	MD STIFF FACTOR
5								
10	557	8.5	657	29.2	287	9.8	4.1	86
	529	5.4	618	28.7	323	11.2	4.0	83
	563	5.0	633	28.8	323	11.2	4.1	86
	534	8.2	654	28.9	305	10.5	4.6	90
15	629	6.9	725	30.2	305	10.1	4.7	91
	632	3.9	753	29.3	287	9.8	4.5	95
	571	6.9	682	28.9	297	10.3	4.5	96
	623	6.4	724	28.7	292	10.2	4.7	97
	638	7.2	744	29.7	297	10.0	4.6	98
20	511	5.3	607	28.3	361	12.7	3.5	89
	577	7.9	687	29.1	312	10.7	4.2	96
	503	5.2	598	28.9	348	12.0	4.0	92
	428	8.3	477	20.7	249	12.0	3.5	55
	324	6.0	391	19.6	315	16.0	3.4	58
25	356	11.2	474	19.8	269	13.5	3.4	66
	383	5.8	453	20.1	325	16.1	3.8	71
	306	14.8	362	19.6	330	16.8	3.4	71
	299	9.4	398	19.9	335	16.8	3.2	77
	415	4.5	499	20.0	287	14.3	3.8	81
30	494	8.6	591	38.0	388	10.1	3.2	83

Referring now to Figures 5-10, various aspects of the invention will be described in further detail.

Figure 5 is a generalized load/elongation curve for a tissue sheet, illustrating the determination of the MD Max Slope. As shown, two points P1 and P2, the distance between which is exaggerated for purposes of illustration, are selected that lie along the load/elongation curve. The tensile tester is programmed (GAP [General Applications Program], version 2.5, Systems Integration Technology Inc., Stoughton, MA; a division of MTS Systems Corporation, Research Triangle Park, NC) such that it calculates a linear regression for the points that are sampled from P1 to P2. This calculation is done repeatedly over the curve by adjusting the points P1 and P2 in a regular fashion along the curve (hereinafter described). The highest value of these calculations is the Max Slope and, when performed on the machine direction of the specimen, is called the MD Max Slope.

The tensile tester program should be set up such that five hundred points such as P1 and P2 are taken over a two and one-half inch (63.5 mm) span of elongation. This provides a sufficient number of points to exceed essentially any practical elongation of the

specimen. With a ten inch per minute (254 mm/min) crosshead speed, this translates into a point every 0.030 seconds. The program calculates slopes among these points by setting the 10th point as the initial point (for example P1), counting thirty points to the 40th point (for example, P2) and performing a linear regression on those thirty points: It stores the slope from this regression in an array. The program then counts up ten points to the 20th point (which becomes P1) and repeats the procedure again (counting thirty points to what would be the 50th point (which becomes P2), calculating that slope and also storing it in the array). This process continues for the entire elongation of the sheet. The Max Slope is then chosen as the highest value from this array. The units of Max Slope are kg per three-inch specimen width. (Strain is, of course, dimensionless since the length of elongation is divided by the length of the jaw span. This calculation is taken into account by the testing machine program.)

Figure 6 is a plot of Bulk versus Panel Stiffness for bath tissues made in accordance with this invention (Examples 1-20 plotted as points a-t, respectively) and for a number of commercially available creped bath tissues plotted as either a "1" representing a single-ply product, a "2" representing a two-ply product and a "3" representing a three-ply product. This plot illustrates the unique combination of high Bulk and low stiffness possessed by the products of this invention.

Figure 7 is a plot of Panel Stiffness versus MD Max Slope for the same products, illustrating the correlation of MD Max Slope with stiffness as measured by a trained sensory panel. This plot shows that MD Max Slope is an objective measure of panel stiffness.

Figure 8 is a plot of Bulk versus MD Max Slope for the same products, illustrating the combination of high Bulk and low stiffness (as measured by the MD Max Slope) exhibited by the products of this invention.

Figure 9 is a plot similar to the plot of Figure 7, but Panel Stiffness is plotted against the MD Stiffness Factor instead of MD Max Slope, illustrating that the MD Stiffness Factor is also a valid measure of stiffness.

Figure 10 is a plot similar to the plot of Figure 8 with Bulk plotted versus the MD Stiffness Factor, illustrating the combination of high Bulk and low stiffness (as measured by the MD Stiffness Factor) exhibited by the products of this invention.

5 It will be appreciated that the foregoing examples, given for purposes of illustration, are not to be construed as limiting the scope of this invention, which is defined by the following claims and all equivalents thereto.

CLAIMS

1. A soft tissue product comprising one or more tissue plies and having a Bulk of about 9 cubic centimeters per gram or greater and a MD Max Slope of about 10 or less.
2. The product of Claim 1 having a Bulk of from about 9 to about 20 cubic centimeters per gram.
3. The product of Claim 1 having a Bulk of from about 10 to about 15 cubic centimeters per gram.
4. The product of Claim 1, 2 or 3, having a MD Max Slope of about 5 or less.
5. The product of Claim 1, 2 or 3, having a MD Max Slope of from about 3 to about 6.
6. A soft tissue product comprising one or more uncreped throughdried tissue plies and having a MD Max Slope of about 10 or less.
7. The product of Claim 6 having a Bulk of about 6 cubic centimeters per gram or greater.
8. The product of any preceding Claim, having a machine direction stretch of about 10 percent or greater.
9. The product of any of Claims 1 to 7, having a machine direction stretch of from about 15 to about 25 percent.
10. The product of any preceding Claim, having one uncreped throughdried ply.
11. The product of any of Claims 1 to 9, having two uncreped throughdried plies.
12. The product of any of Claims 1 to 9, having three uncreped throughdried plies.
13. The product of any of Claims 1 to 9, having four uncreped throughdried plies.

14. The product of any preceding Claim, wherein said plies have two or more layers, at least one layer being an outwardly facing layer and comprising about 20 percent or more curled fibers.
15. The product of any of Claims 1 to 13, wherein said plies have two or more layers, at least one layer being an outwardly facing layer and comprising about 80 percent or more curled fibers.
16. A soft tissue product comprising one or more tissue plies and having a Bulk of about 9 cubic centimeters per gram or greater and a MD Stiffness Factor of about 150 or less.
17. The product of Claim 16 having a Bulk of from about 9 to about 20 cubic centimeters per gram.
18. The product of Claim 16 having a Bulk of from about 10 to about 15 cubic centimeters per gram.
19. The product of Claim 16, 17 or 18, having a MD Stiffness Factor of about 100 or less.
20. The product of Claim 16, 17 or 18, having a MD Stiffness Factor of from about 50 to about 100.
21. A soft tissue product comprising one or more uncreped throughdried tissue plies and having a MD Stiffness Factor of about 150 or less.
22. The product of Claim 21 having a Bulk of about 6 cubic centimeters per gram or greater.
23. The product of any of Claims 16 to 22 having a machine direction stretch of about 10 percent or greater.
24. The product of any of Claims 16 to 22, having a machine direction stretch of from about 15 to about 25 percent.

25. The product of any of claims 16 to 24, having one uncreped throughdried ply.
26. The product of any of claims 16 to 24, having two uncreped throughdried plies.
27. The product of any of claims 16 to 24, having three uncreped throughdried plies.
28. The product of any of claims 16 to 24, having four uncreped throughdried plies.
29. The product of any of Claims 16 to 28, wherein said plies have two or more layers, at least one layer being an outwardly facing layer and comprising about 20 percent or more curled fibers.
30. The product of any of Claims 16 to 28, wherein said plies have two or more layers, at least one layer being an outwardly facing layer and comprising about 80 percent or more curled fibers.
31. A soft single-ply bath tissue comprising a layered, uncreped throughdried tissue sheet having an air side layer comprising about 80 weight percent or greater curled eucalyptus fibers and a fabric side layer comprising about 80 weight percent or greater curled eucalyptus fibers, said tissue having a Bulk of from about 9 to about 20 cubic centimeters per gram, a MD Stiffness Factor of from about 50 to about 100, and a machine direction stretch of from about 10 to about 25 percent.
32. A method of making a soft uncreped throughdried tissue sheet comprising:
 - (a) forming an aqueous suspension of papermaking fibers having a consistency of about 20 percent or greater;
 - (b) mechanically working the aqueous suspension at a temperature of about 140°F. or greater with a power input of about 1 horsepower-day per ton of dry fiber or greater to curl the fibers;
 - (c) diluting the aqueous suspension of curled fibers to a consistency of about 0.5 percent or less and feeding the diluted suspension to a tissue-making headbox;

- (d) depositing the diluted aqueous suspension of papermaking fibers onto a forming fabric to form a wet web;
 - (e) dewatering the wet web to a consistency of from about 20 to about, 30 percent;
 - (f) transferring the dewatered web from the forming fabric to a transfer fabric traveling at a speed of from about 10 to about 80 percent slower than the forming fabric;
 - (g) transferring the web to a throughdrying fabric whereby the web is macroscopically rearranged to conform to the surface of the throughdrying fabric; and
 - (h) throughdrying the web to final dryness.
33. The method of Claim 32 wherein the fibers are curled by mechanical working while passing through a disperger.
34. The method of Claim 32 or 33, wherein the fibers are surface treated with a chemical softening agent.
35. The method of Claim 32, 33 or 34, wherein the curled fibers are eucalyptus fibers.
36. The method of Claim 32, 33, 34 or 35, wherein the curled fibers are deposited onto the forming fabric as one or two layers of a multiple layer web.
37. The method of Claim 36 wherein the web comprises an inner layer and two outer layers, at least one outer layer comprising the curled fibers.
38. The method of Claim 37 wherein both outer layers comprise the curled fibers.
39. The method of any of Claims 32 to 38 wherein all of the fibers in the web have been mechanically worked as set forth in step (b).

40. The method of any of Claims 32 to 39, wherein the curled fibers are deposited onto the forming fabric as the air side layer and the fabric side layer of the web.

41. A method of making a tissue sheet in which a wet web is transferred from a forming fabric to a drying fabric via a separate transfer fabric, wherein the transfer fabric is designed to provide machine direction stretch, and the drying fabric is designed to provide cross machine direction stretch.

42. A method of making a tissue sheet in which a wet web is transferred from a forming fabric to a drying fabric via a separate transfer fabric, wherein the transfer fabric is designed for rush transfer, and the drying fabric is designed to deliver bulk.

43. A tissue sheet made in accordance with the method of any of claims 32 to 42.

44. A tissue product substantially as hereinbefore described with reference to the accompanying drawings.

45. A method of making a tissue sheet substantially as hereinbefore described with reference to the accompanying drawings.

Relevant Technical Fields

Search Examiner
 ALEX LITTLEJOHN

(i) UK Cl (Ed.M) D1R (RBF, RFZ, RGZ)

Date of completion of Search
 28 JULY 1994

(ii) Int Cl (Ed.5) A47K; D21F; D21H

Documents considered relevant following a search in respect of Claims :-
 1-5, 8-20, 23-30, 32-40, 43

Databases (see below)

(i) UK Patent Office collections of GB, EP, WO and US patent specifications.

(ii) ONLINE DATABASES: WPI

Categories of documents

- | | |
|---|---|
| X: Document indicating lack of novelty or of inventive step. | P: Document published on or after the declared priority date but before the filing date of the present application. |
| Y: Document indicating lack of inventive step if combined with one or more other documents of the same category. | E: Patent document published on or after, but with priority date earlier than, the filing date of the present application. |
| A: Document indicating technological background and/or state of the art. | &: Member of the same patent family; corresponding document. |

Category	Identity of document and relevant passages	Relevant to claim(s)
A	GB 2006296 A (KIMBERLY-CLARK) see whole document	
A	GB 1533045 (PROCTER & GAMBLE) see whole document	
A, P	EP 0568404 A1 (KIMBERLY-CLARK) see whole document	
A	US 4488932 (EBER) see whole document	

Databases:The UK Patent Office database comprises classified collections of GB, EP, WO and US patent specifications as outlined periodically in the Official Journal (Patents). The on-line databases considered for search are also listed periodically in the Official Journal (Patents).