



US 20070193180A1

(19) **United States**

(12) **Patent Application Publication**
Plante

(10) **Pub. No.: US 2007/0193180 A1**

(43) **Pub. Date: Aug. 23, 2007**

(54) **FLOORING SYSTEM AND METHOD OF
INSTALLING SAME**

Related U.S. Application Data

(60) Provisional application No. 60/560,184, filed on Apr. 6, 2004.

(76) Inventor: **Rejean Plante**, Drummondville (CA)

Publication Classification

Correspondence Address:
GOUDREAU GAGE DUBUC
2000 MCGILL COLLEGE
SUITE 2200
MONTREAL, QC H3A 3H3 (CA)

(51) **Int. Cl.**
E04B 2/00 (2006.01)
(52) **U.S. Cl.** **52/592.1**

(21) Appl. No.: **10/599,684**
(22) PCT Filed: **Apr. 6, 2005**
(86) PCT No.: **PCT/CA05/00519**
§ 371(c)(1),
(2), (4) Date: **Oct. 5, 2006**

(57) **ABSTRACT**
A flooring system is provided with a combination of features which work with the expansion/contraction naturally occurring when wood is subjected to moisture variations. Part of the process is taken within the plank (52), which is the internal or intra-plank compensation system (82) and another part is taken by interacting between the planks (52) which is the inter-plank compensation system (50, 60).

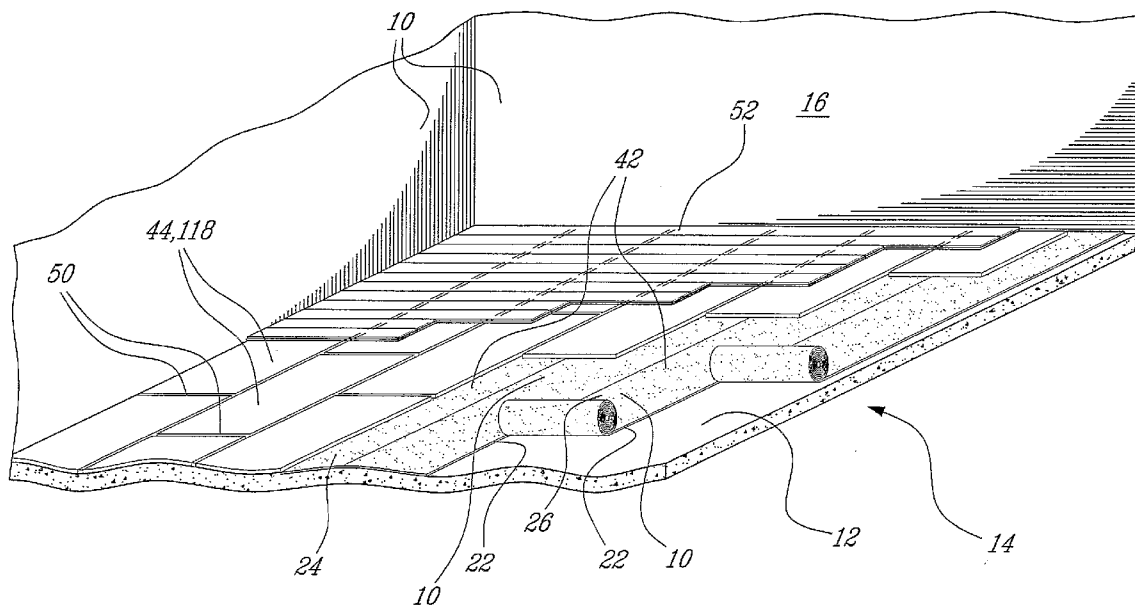

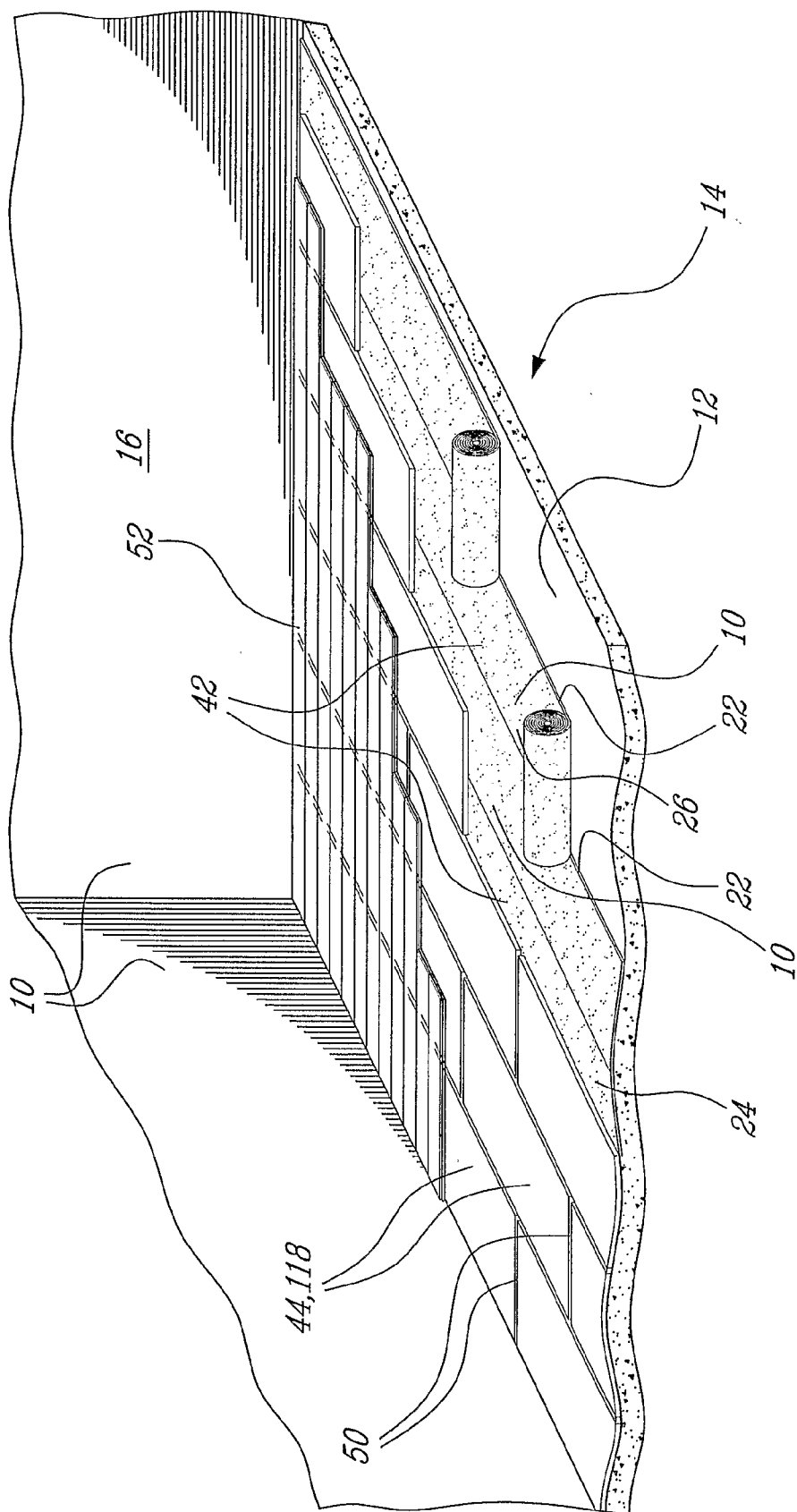

FIG-1

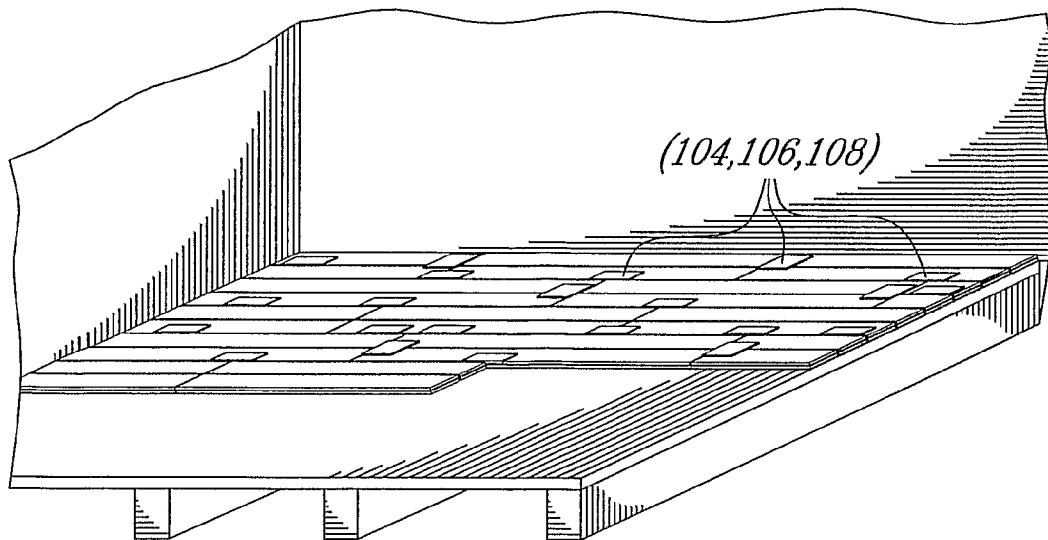

FIG. 2A

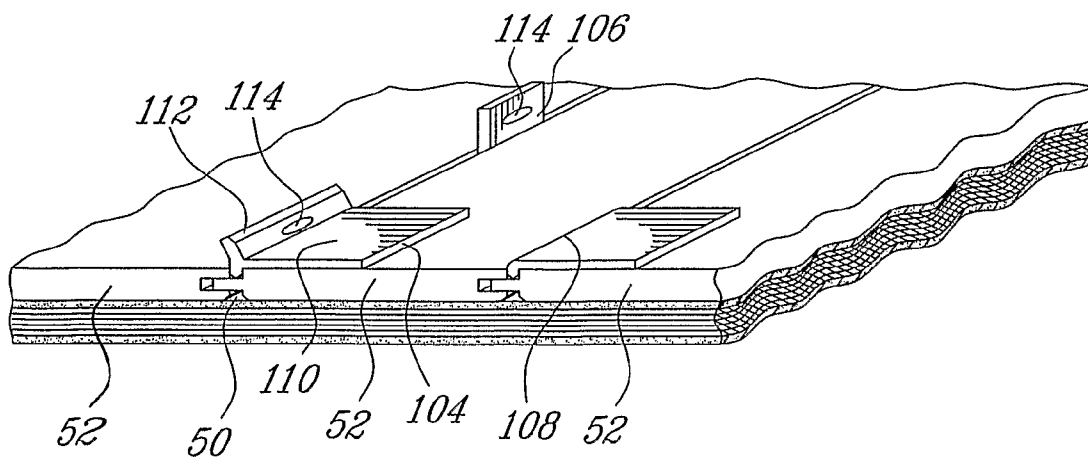

FIG. 2B

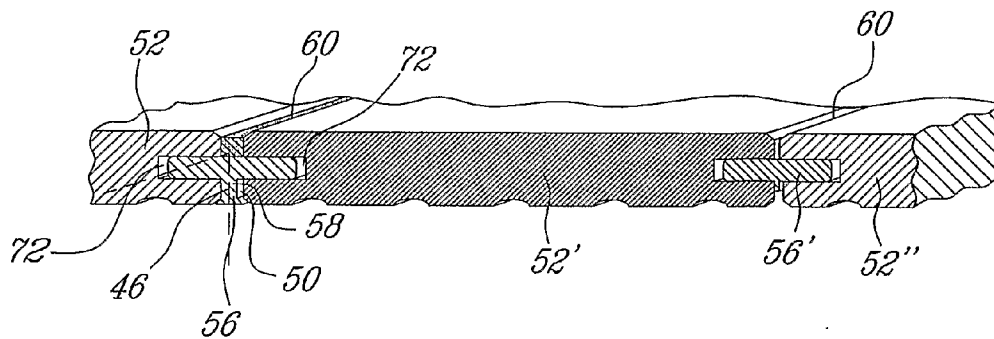

FIG-3A

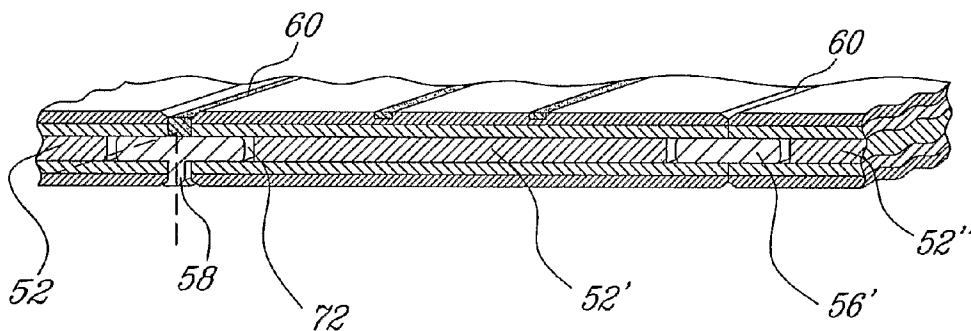

FIG-3B

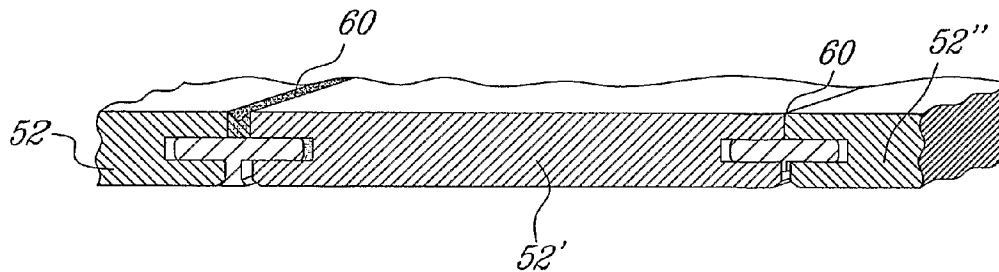

FIG-3C

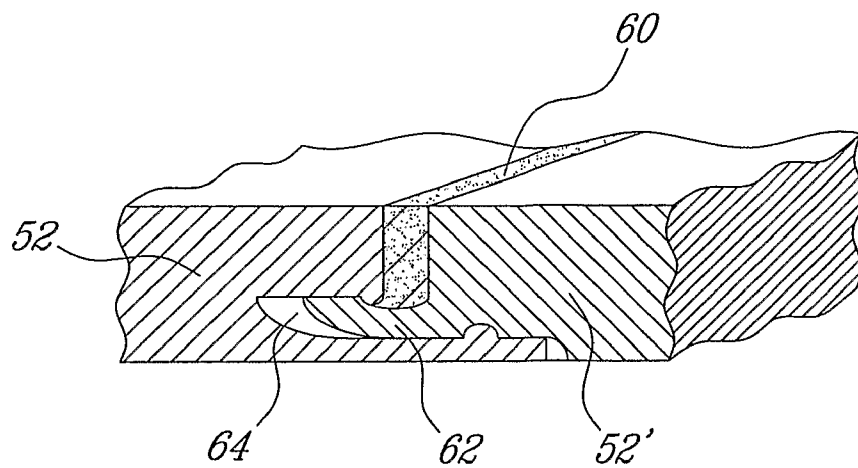

Fig-3D

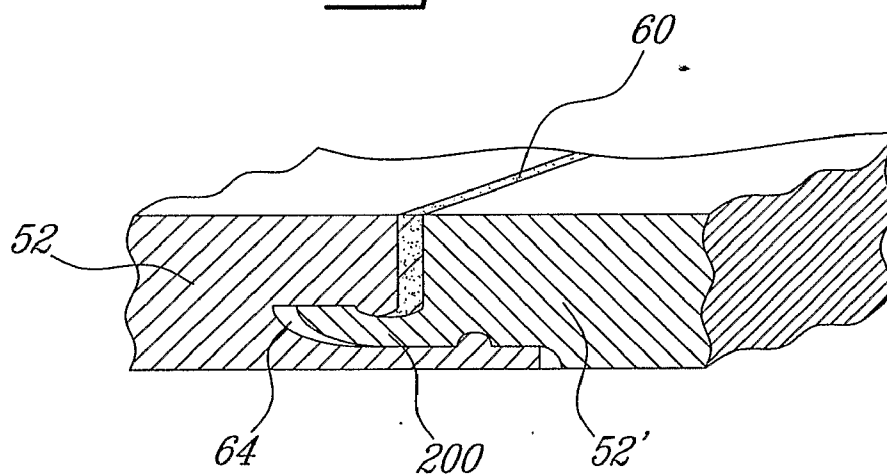

Fig-3E

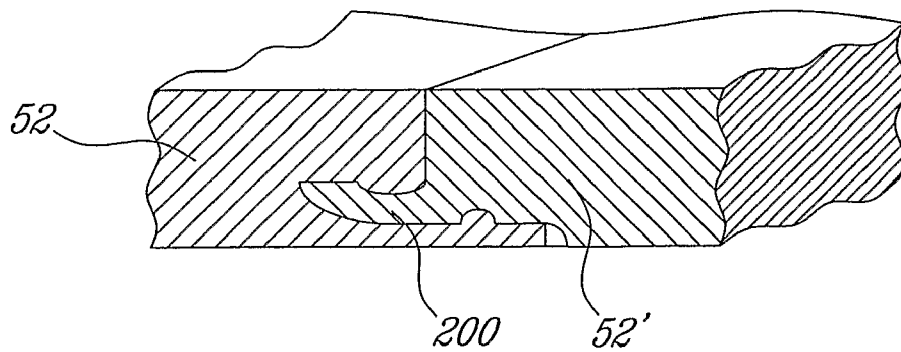

Fig-3F Prior Art

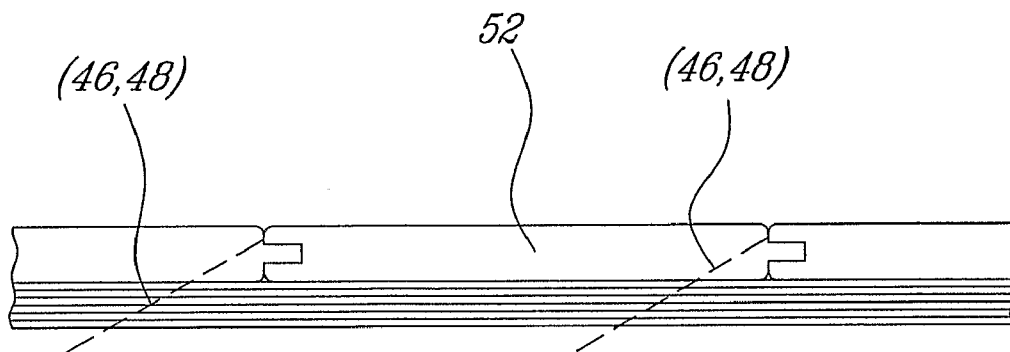

Fig-4A

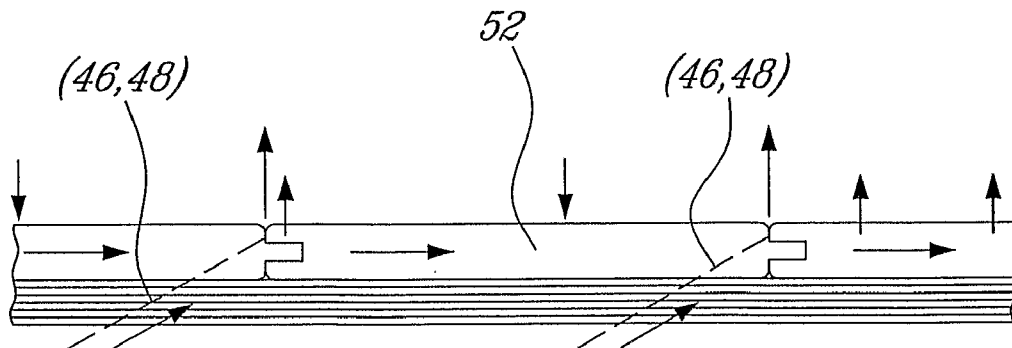

Fig-4B Prior Art

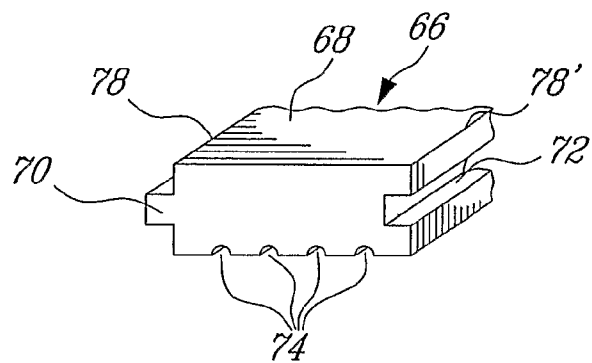

Fig- 5A Prior Art

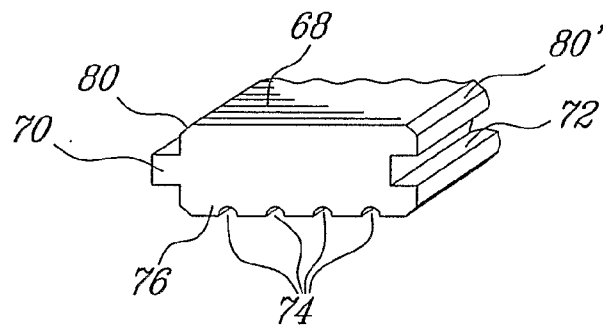

Fig- 5B

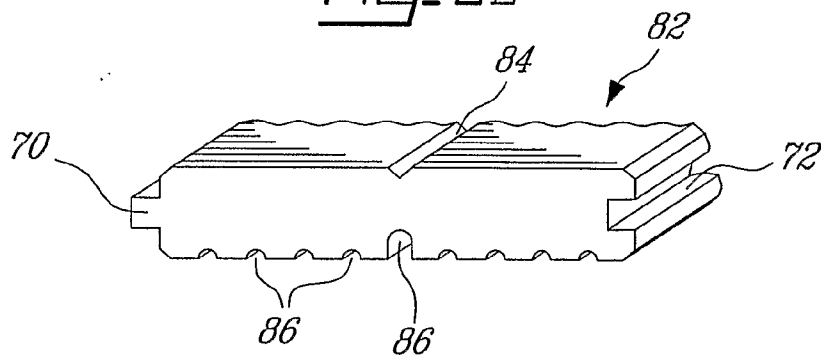

Fig- 6A

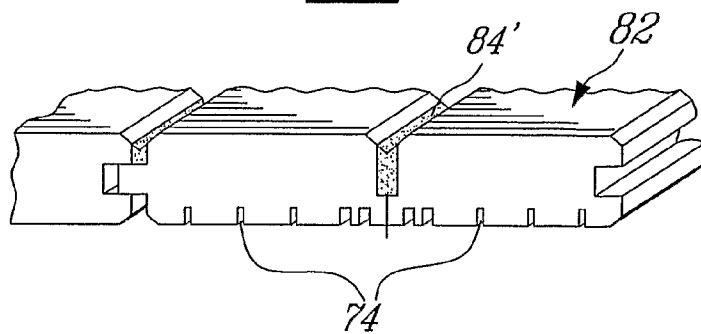

Fig- 6B

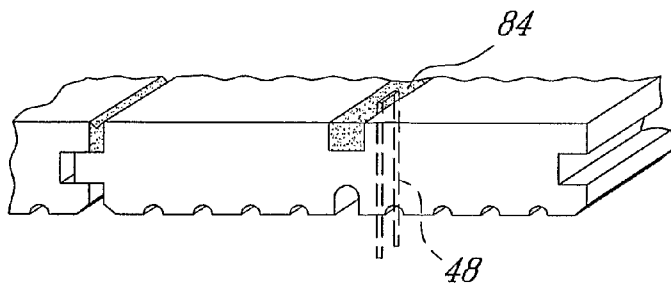

FIG-7

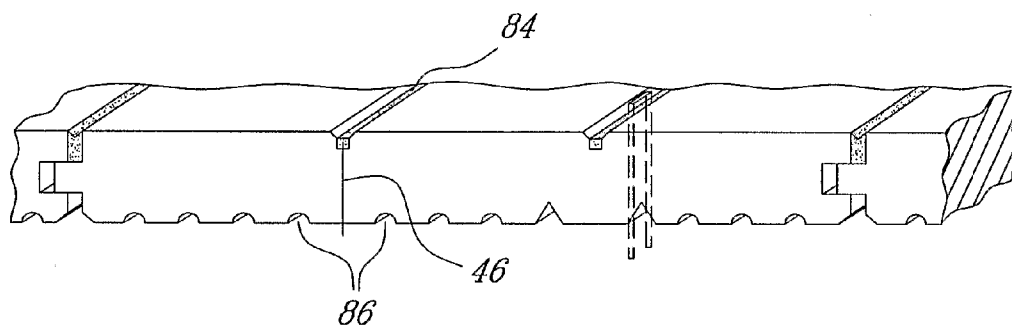

FIG-8A

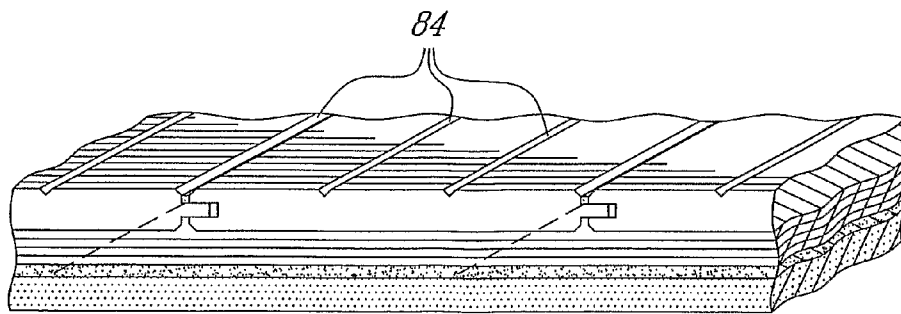

FIG-8B

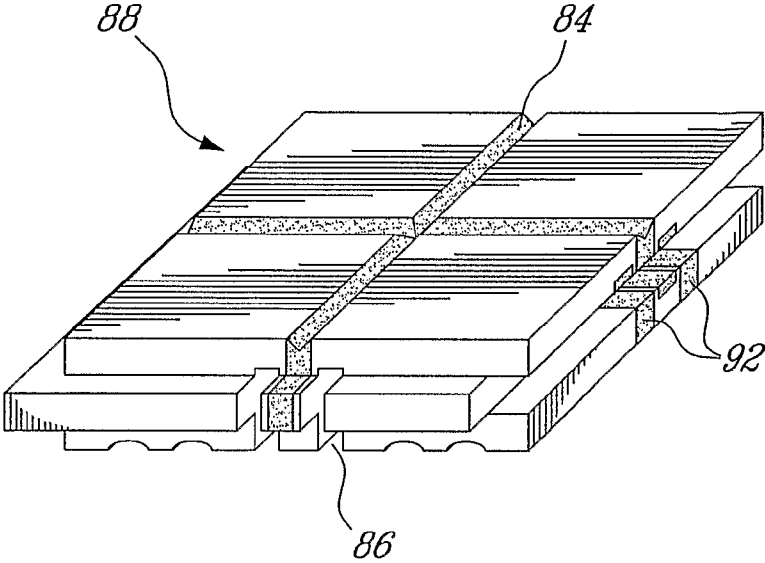

Fig-9

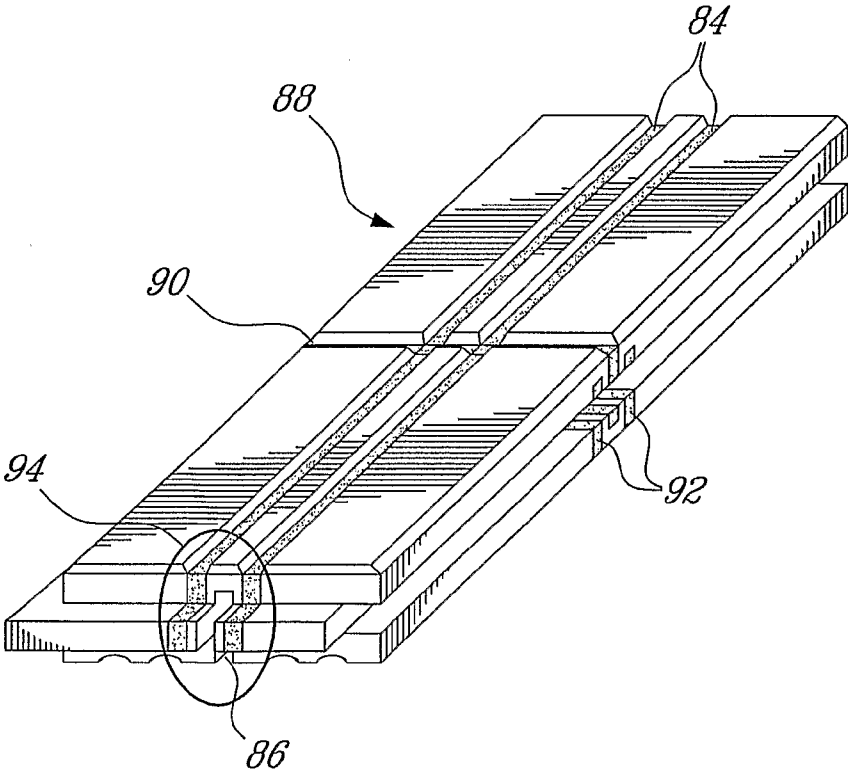

Fig-10

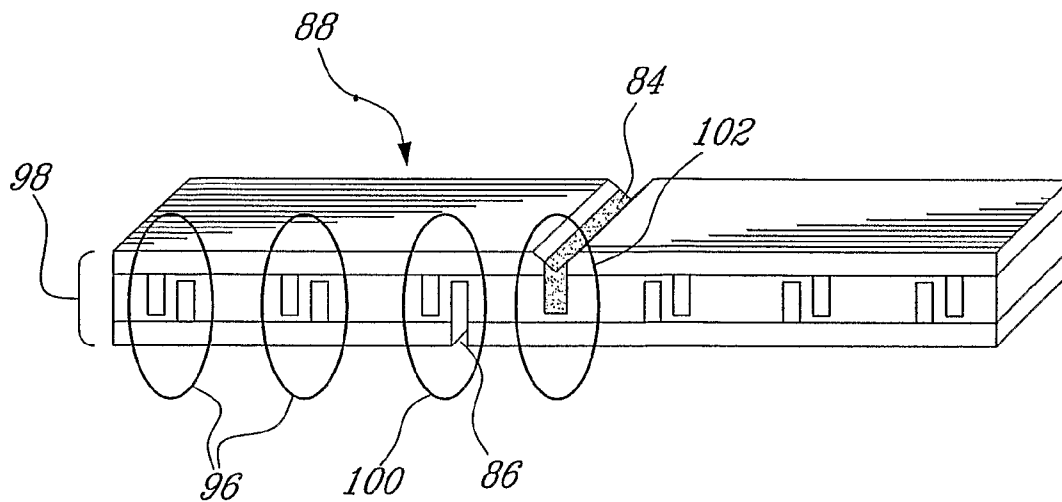

Fig-11

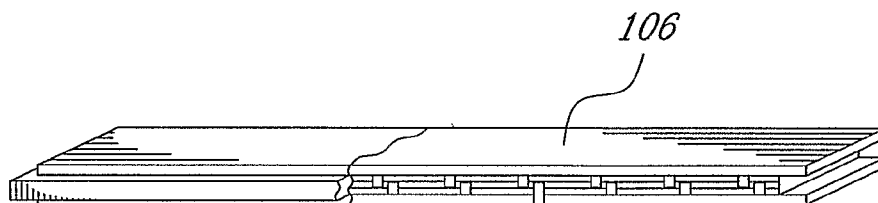

Fig-12

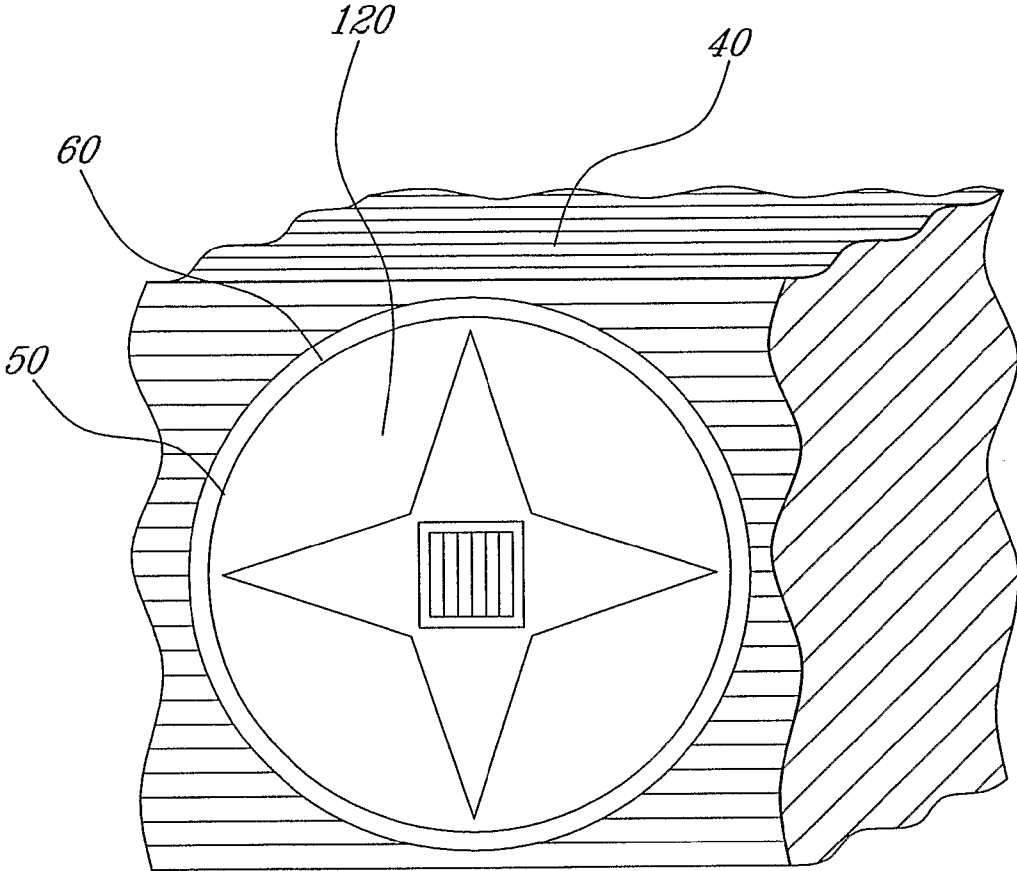

FIG-13

FLOORING SYSTEM AND METHOD OF INSTALLING SAME

BACKGROUND OF THE INVENTION

[0001] 1. Field of the Invention

[0002] This invention relates generally to flooring but more particularly to a floor having means for compensating for wood expansion and contraction.

[0003] 2. Description of the Prior Art

[0004] The prior art reveals many developments in wood floors or at least to floors that look like wood. Indeed, recent developments have proposed floor structures in which natural wood makes but a very small percentage of the content or none at all. A lot of substrates are made of wood based products mixed with various resins and polymers covered with a thin veneer of either natural wood or of melamine with a hard varnish finish. Because of problems related to the use of carpeting, mainly due to reported cases of allergies, wood floors or any such floor coverings made to look like wood have taken a greater share of the marketplace. Also, wood or wood looking finishes can be used on walls and even ceilings.

[0005] Besides the combination of materials used, means for securing floor planks or strips (strips referring generally to pieces of flooring 4.5 inches or less while planks refer to wider pieces of flooring) on top of a subfloor have been developed as well as means for securing the floor's individual planks or strips together as a whole. For example: Although most floor strips or planks are profiled in "tongue and groove" fashion, some are "groove and groove" and use a spline to replace the tongue in order to bridge two adjacent planks or strips together so that they are evened up. Alternatively a system of clips fastened to the sub floor engages the grooves in order to secure the planks or strips onto the subfloor.

[0006] Due to wood's hygroscopic nature, variations in relative humidity make it expand or shrink. This means that when wood is exposed to air, it will either dry out or pick up moisture and moisture absorption causes wood to expand until the fibers are saturated, which occurs when the moisture content (MC) of wood reaches 25-30%, beyond that, wood no longer expands.

[0007] So, as the wood expands, the floor strips or planks grow wider and longer and, inversely, when the MC drops, the floor strips or planks will shrink in width and also in length.

[0008] It should be noted that most of the wood expansion and shrinkage occurs perpendicularly to the direction of the wood fibers (the grain) and since virtually all traditional wood floors have the wood fibers aligned along the length of the strip or plank, most of the expansion will occur along the width. For any given length a piece of wood will expand or shrink by 0.1% of its length.

[0009] If the floor was installed when its MC was higher than the NOFMA recommended industry rating, each plank will start to reduce its moisture content in order to acclimate itself to the relative humidity of the building. Shrinkage will cause gaps between the floor strips or planks. Over time, these gaps can become filled with dirt and grime which can host germs or even microorganisms which can attack wood

fibers since the sides of floor strips or planks are not varnished or sealed in any way like the top finished face is. Introducing moisture into the side of the strips or planks will cause a localized swelling of the sides of the strips or planks. If moisture remains for too long a period, eventually the whole plank or strip will expand. If there is too much dirt or grime it can even impede any possibility of expansion which will force the strips or planks to either cup, crown or sustain severe deformation which could result in either major resurfacing or even replacement of the entire floor, which is costly and should preferably be avoided.

[0010] In order to reduce the formation of such gaps in today's floor installations, various means attempting to control expansions and contractions have been developed. One such means comprises a top layer, a bottom layer and a core layer sandwiched in between and which is made up of a series of transverse lattes. Since the wood grain of those lattes is set transverse to the wood grain of the other layer(s) it will help reduce the expansion and contraction along the width.

[0011] The wider a plank of solid wood is, the higher the risk that it will warp along its width. Either in a convex manner or in a concave manner. This is why planks of solid wood are rarely wider than 5 in. To overcome that limitation, multi-ply floors made of crossed grain glued layers were developed because they are less prone to warping and can therefore come in much wider width which are finished with a veneer made to look like hardwood strips or planks. Another way is to glue a veneer on top of a core made of a composite material. The latter has more variations in both its length and width since the wood fibers do not have any particular direction and that is why it is preferably installed "floating" so that the entire floor surface can expand and contract at will. This has the inconvenience of requiring an expansion joint which needs to be covered. This expansion joint cover is generally very apparent and not very esthetically pleasing. Moreover, since it is installed with an overlap covering the top of the floor it cannot be level with the floor and creates an undesirable "threshold" appearance.

[0012] To prevent curling lengthwise, this curling often referred to as "ski warp" or "barrel curl" or even "banana curl", cross grain lattes spaced apart at the bottom of a strip or plank of wood are used. This can also allow a strip or plank to follow small unevenness in the subfloor.

[0013] Because of the complexity of wood, there is no wood or simulated wood flooring system today which can solve all the problems and there is therefore a need for an improved flooring system.

SUMMARY OF THE INVENTION

[0014] It is an object of this invention to provide a flooring system which can compensate for the expansion and contraction of wood used for flooring purposes.

[0015] It is another object of this invention to provide a flooring system that does not require a traditional expansion joint cover.

[0016] It is another object of this invention to provide a flooring system that reduces consumption of wood by having a groove and groove profile.

[0017] For the sake of simplicity, in the following discussion, the term wood plank will describe both strips and planks.

[0018] Therefore, in accordance with a general aspect of the present invention, there is provided a flooring system using a combination of features which work with the expansion/contraction naturally occurring when wood is subjected to moisture variations. Part of the process is taken within the plank, which is the internal or intra-plank compensation and another part is taken by interacting between the planks which is the inter-plank compensation.

[0019] The present invention is applicable to either solid wood planks or to multiply, engineered, MDF or HDF planks. The planks may be cut so that they have either the tongue and groove profile of typical wood floors or an innovative "groove on all sides" profile and a special surface groove as well as a system of grooves placed in the core, inner core or anywhere within the plank to give it a spring-like expansion and contraction.

[0020] By being able to work with for the expansion/contraction, it is possible to create planks that are much wider than usually done in the industry which makes it possible for an installer to install a floor much faster since fewer pieces are needed to cover a given surface.

[0021] The foregoing and other objects, features, and advantages of this invention will become more readily apparent from the following detailed description of a preferred embodiment with reference to the accompanying drawings, wherein the preferred embodiment of the invention is shown and described, by way of examples. As will be realized, the invention is capable of other and different embodiments, and its several details are capable of modifications in various obvious respects, all without departing from the invention. Accordingly, the drawings and description are to be regarded as illustrative in nature, and not as restrictive.

[0022] In accordance with a further general aspect of the present invention, there is provided a flooring system comprising a number of flooring members installed next to each other in a coplanar relationship so as to define an open top inter-member gap between each adjacent pairs of flooring members, and a compressible/extensible sealing filler in said open top inter-member gap, said sealing filler being visible and accessible from above.

[0023] In accordance with a further general aspect of the present invention, there is provided a flooring system comprising first and second flooring members adapted to be laid down side-by-side in a coplanar relationship, and a floating interlocking joint between said first and second flooring members, said floating interlocking joint comprising a compressible/stretchable filler provided in a gap between opposed facing sides of said first and second flooring members, said filler being adhesively engaged with said opposed facing sides, and a locking key provided on a first one of said opposed facing sides and engageable with a complementary locking groove provided in a second one of said opposed facing sides, said locking key having a limited freedom of movement within said locking groove in a direction perpendicular to said opposed facing sides to accommodate expansion and contraction movements of said first and second flooring members.

[0024] In accordance with a further general aspect of the present invention, there is provided a floor plank adapted to be laid in a coplanar side-by-side relationship with similar

floor planks to form a floor surface, said floor plank comprising an internal expansion/contraction accommodation means to provide for local absorption of floor expansion and contraction movements and prevent chain transmission of stresses from one plank to another, said internal expansion/contraction accommodation means comprising at least one top groove defined in an exposed top surface of said floor plank.

[0025] In accordance with a still farther general aspect of the present invention, there is provided a flooring member adapted to be laid in a side-by-side coplanar relationship with similar floor planks to form a substantially level surface, said floor plank having a bottom surface, a series of grooves defined in said bottom surface, and wherein at least one of said grooves is filled with a filling material having adhesive properties.

[0026] In accordance with a still further general aspect of the present invention, there is provided a flooring system comprising first and second flooring members adapted to be laid down side-by-side in a coplanar relationship, and an interlocking joint between said first and second flooring members, said interlocking joint comprising a compressible/stretchable filler provided in a gap between opposed facing sides of said first and second flooring members, said filler being adhesively engaged with said opposed facing sides and retaining said first and second flooring members together in an assembled relationship, and a locking key provided on a first one of said opposed facing sides and engageable with a complementary locking groove provided in a second one of said opposed facing sides.

BRIEF DESCRIPTION OF THE PREFERRED EMBODIMENT

[0027] FIG. 1 is a perspective view of a floor assembly;

[0028] FIGS. 2*ab* are perspective views showing the laying of a floor using inter-plank spacing with spacers;

[0029] FIG. 3*a* is a perspective view of groove and groove profile, hardwood, with two types of splines;

[0030] FIG. 3*b* is a perspective view of groove and groove profile, multi-ply, with two types of splines;

[0031] FIG. 3*c* is a perspective view of groove and groove profile, MDF/HDF with two types of splines;

[0032] FIG. 3*d* is a perspective view of a floating key lock joint and filler;

[0033] FIG. 3*e* is a perspective view of a floating key lock joint and filler when compressed as a result of plank expansion;

[0034] FIG. 3*f* is a perspective view of a key lock joint of the prior art;

[0035] FIGS. 4*ab* are perspective view of prior art regarding pushing out of nailing;

[0036] FIGS. 5*ab* are perspective view of prior art hardwood floor;

[0037] FIGS. 6*ab* are perspective view of a multi-groove system;

[0038] FIGS. 7, 8*ab* illustrate variations of the multi-groove system with inter-plank;

[0039] FIGS. 9, 10 are perspective view of a multi-ply floor with spring system and cross grain groove applicable lengthwise and crosswise;

[0040] FIG. 11 is a perspective view of close grouping.

[0041] FIG. 12 is a perspective view of cross grain planks; and

[0042] FIG. 13 is a plan view of an insert.

DETAILED DESCRIPTION OF THE PREFERRED EMBODIMENT

[0043] Now referring to the drawings and more particularly to FIG. 1, there is shown a floor assembly generally comprising strips of moisture barrier membranes (10) laid down next to each other in a coplanar relationship on a subfloor (12), and an intermediate layer of substantially rigid panels (44) installed next to each other in a coplanar relationship on top of the moisture barrier membranes (10) for receiving a floor covering including a plurality of floor covering planks (52) installed transversally to the intermediate panels. The moisture barrier membrane (10) is as described in applicant US provisional application No. 60/560,332 filed on Apr. 6, 2004, the contents of which is herein incorporated by reference.

[0044] As shown in FIGS. 2*ab*, an open top inter-plank spacing (50) is provided between each plank (52) so that each plank (52) is allowed to expand. The spacing depends on a variety of factors such as the nature of the plank (essence of the wood), whether it is of a single piece hardwood, multi-ply, engineered, MDF, HDF or otherwise. Once a spacing is determined from the manufacturer's specs which are based on the specification of the type of floor installed, moisture content, as well as the typical humidity content of the geographical location the floor is to be installed, installation can proceed. When installing, a proper spacer tool (104, 106, and 108) will set the recommended spacing and insure that each plank (52) is set parallel to the next. In order to maintain parallelism, it is preferable, when nailing, stapling or gluing, that all spacer tools (104, 106, and 108) are in line one behind the other for several rows of planks as per FIG. 2*b*. Spacing between planks (52) is generally at least over twice the expansion of a plank (52) so that a contractible/extensible sealing filler (60) (FIG. 3) can accommodate the plank expansion. The filler (60) is adhesively engaged with the opposed facing sides of adjacent planks (52) so as to retain the planks together in an assembled fashion. Back to the spacer tool (104), since it is not a true square angle, squeezing it between planks (52) lifts the long flat piece (110) when the appropriate spacing is obtained. To insure parallelism, a minimum of two spacers (104, 106, 108) are preferably used. Both spacers (104) and (106) have grab holes (114) to remove them after use except that spacer (104) has an extension (112) in which the grab hole (114) is defined.

[0045] Referring generally to FIGS. 3, in the case of a groove and groove profile, a spline is used to bridge each individual plank (52). A T-shaped spline (56) is preferably used in that it advantageously allows for nails (46) (FIG. 4) or staples (48) to be inserted vertically right through the vertical stem or leg (58) of the spline as well as the usual diagonal insertion. The T-shaped spline (56) can be made of any type of material or combination of materials judged

appropriate for the use and can be used for all groove and groove materials such as hardwood, multi-ply, engineered, MDF, HDF or any other such types. As will be seen hereinafter, the stem portion (58) is advantageously used as a stopper to prevent excessive compression of the inter-plank filler (60) as a result of a plank expansion.

[0046] When a first plank (52) is laid, the T-shaped spline (56) follows by being inserted into a groove (72) until the leg (58) of the "T" spline (56) abuts against the side of the first plank (52), and then a second grooved plank (52') is engaged with the T-shaped spline (56), the side of the second plank being spaced from the leg (58) by a predetermined distance. The spacing set between planks (52, 52') creates a spacing or gap around the T-shaped spline (56) so that it will not interfere with the expansion of the plank (52'). Also, the T-shaped spline (56), being asymmetric, has a longer side to allow for a greater inter-plank spacing. Other possible types of splines are the finger spline (56') and the plain spline (56'').

[0047] Once all the planks (52) are in place, the filler (60) is applied into each open top inter-plank spacing (50) to seal it. Once applied, the filler (60) remains visible and directly accessible. The filler (60) can be provided in the form of a variety of sealers already available on the market for uses not necessarily related to flooring but which are preferably compressible up to about 50% of their sizes and preferably 100% stretch. The filler (60) can vary its specs by varying its chemistry so that higher or lower percentages of stretch can be achieved and does preferably not contaminate varnishes. The filler must also have waterproof or hydrophobic properties and be able to stick permanently to wood during expansion/compression cycles. It can be transparent or have a matching color to the wood or can have a contrasting color or even be matched to the color of the walls and can open new possibilities for interior decorators. It is directly accessible and, thus, it is easy to remove the product if one would like to change the color or else, after sanding and re-varnishing the floor, in which case the filler (60) would be inserted only after the varnishing is completed. The filler (60) could for instance be of a malleable polyolefin adhesive. The filler (60) properties makes inter-plank joints totally impervious to moisture or water infiltration at the edges of the plank (52), a source of swelling for wood, and also impedes the accumulation of dirt and grime, thus making the inter-plank spacing (50) totally sanitary. Moreover, the plank (52) is in not restricted in its expansion or contraction by the presence of the filler (60) and no moisture or water is allowed to enter the side of the plank (52) where no varnish is present.

[0048] The width of the stem (58) of the T-shaped spline (56) is selected to ensure that the inter-plank gap (50) always remains open at the top to prevent excessive compression of the filler (60). It basically acts as a safety feature to prevent the filler (60) from being compressed beyond its compression capabilities. Other types of stoppers could be provided between the planks (52) to protect the filler (60).

[0049] As a further alternative, a floating interlocking joint (see FIG. 3*d*) including a floating lock key (62) can be used as long as its complementary locking groove (64) is deep enough to allow for expansion/contraction displacements. This type of floor can be stapled, nailed or left floating. As shown in FIG. 3*d*, the floating lock key (62) has a depthwise

freedom of movement in the locking groove (64) between the end wall of the groove (64) and the locking projection depending downwardly from the entry portion of the groove (64). The shape or specific configuration of the interlocking joint is not relevant as long as it provides a play in the interlocking direction. The floating interlocking joint defines an inter-plank gap which is filled with the filler, as per the way described herein-above with respect to FIGS. 3a, b and c. The play between the locking key (62) and the end wall of the locking groove (64) is selected to ensure that the inter-plank gap (50) remains open at the top in order to prevent excessive compression of the filler (60).

[0050] Also, the filler (60) can be used with conventionally designed lock joints as shown at (200) in FIG. 3e to seal in between planks (52, 52') in order to stop moisture infiltration—a cause of swelling. For all floors on which it is to be used, the filler (60) can be applied: during the manufacturing process, during the floor installation in the shape of a roll which is applied as long strips or by direct application into the spacing (50) once the floor has been installed.

[0051] In all cases, it is preferable that the sealer or filler (60) be applied so as to have a concave shape (e.g. V-shaped) so that it is never higher than the surface of the floor and dust and sand can be pushed in so that it will minimize potential scratching of the floor surface.

[0052] From FIGS. 4ab, it can be appreciated that if a plank (52) has no room for expansion, the wood will expand by way of least resistance. In these before and after views of a prior art floor, if during expansion wood encounters resistance from a nail (46) or staple (48) to the left, it will expand to the right where the nail (46) or staple (48), generally inserted at an angle, will be lifted. Once lifted, a nail (46) or staple (48) will not come back to its original position and the floor becomes an unintentional “floating floor” which is subject to cupping, warping and squeaking.

[0053] FIGS. 5ab show prior art hardwood planks (66) having a top finished face (68), a tongue (70) and a groove (72) and a series of underside grooves (74) on the bottom face (76). The side edges (78, 78') can be square as shown in FIG. 5a or half-beveled (80, 80') in any shape or size as shown in FIG. 5b.

[0054] FIG. 6a shows a multi-groove flooring plank system (82) providing an improved compensation of the expansion/contraction behavior of the planks. The flooring plank system (82) is made to look like two side-by-side strips by having a top groove (84) set in its middle which is preferably, but not necessarily, shaped to look like two half-beveled side edges (80,80') put together. In other words the top groove is mimicking the top adjoining edges of two side by side planks. In vertical alignment with the top groove (84) is a bottom groove (86). The top and bottom grooves (84) and (86) cooperate to provide some transversal springiness to the flooring plank. The grooves (84) and (86) could be offset and deepened to overlap in a thickness direction of the plank to provide a bellows formation or buffering zone in which expansion could be locally absorbed. The central bottom groove (86) is made deeper than the other bottom grooves and is preferably filled with a filling material having adhesive properties. Filler (60) can be used to fill the central groove (86). Excess material is allowed to flow from the central bottom groove (86) to the other bottom grooves. The

filler in the bottom grooves can be used to adhesively retain the plank on the underlying surface and also to provide resiliency to absorb expansion and contraction movement as well as impact from falling objects onto the planks. A curable glue could be used as an alternative to fill at least one of the bottom grooves.

[0055] Each multi-groove plank or floor covering member is designed to handle its part of the expansion/contraction variations as opposed to the prior art hardwood planks (66), most notably “free floating” floor systems where the entire floor surface expands or contracts and gaps of the order of 1/2inch or more have to be made around the perimeter of the room to take in the expansion and an expansion joint trim has to be put at every twenty feet or so, depending upon the specification of the floor, to accommodate the expansion, both lengthwise and widthwise. According to the present multi-groove plank system, the expansion and contraction can be accommodated locally without any impact on the neighboring planks. Accordingly, the peripheral floor covering planks could be fixed in place against the wall of the room without any risk of rupture due to floor expansion and contraction. One problem with having the entire floor surface taking in the expansion or contraction is that if an object, such as a heavy piece of furniture, blocks a section of floor from sliding with the expansion or contraction, there is an uneven deformation in the floor since expansion on either side of that blockage is impeded.

[0056] But, if each multi-groove plank system (82) is responsible for its share of the expansion or contraction, whatever impediment would be strictly isolated. In laying down each multi-groove plank system (82) part of the expansion is taken within the plank (52) which is the “intra-plank” expansion and when care is taken to have a proper spacing between each multi-groove plank system (82), as described in FIGS. 3, this takes care of the “inter-plank” expansion and contraction.

[0057] Other factors can also affect prior art hardwood planks (66), such as when a plywood subfloor becomes unduly wet in spots for any reason (rain, snow, etc) prior to installation of the floor which will cause the prior art hardwood planks (66) to absorb that excess moisture when it is first laid. Since there is no spacing and no compensation means, each prior art hardwood plank (66), expands, which creates cupping on the floor surface but more importantly, when the plywood of the subfloor loses its moisture, it shrinks and displaces prior art hardwood planks (66), in an uneven fashion since moisture level may not be spread evenly across the subfloor. When, however, each multi-groove plank system (82) compensates by combining the features of intra-plank and inter-plank compensations, the effect is localized and is not felt throughout the floor.

[0058] FIG. 6b shows one possible variation of the multi-groove system (82) wherein the top groove (84') is made deeper and there is no equivalent bottom groove (86) but rather a series of deep cut underside grooves (74'). A blend of various groove depths, widths and shapes aligned or not can be mixed depending upon the result desired. Whatever the variations, whether as in FIG. 7 or FIG. 8, where the look of three planks can be simulated, if nails or staples are desired, they can be hidden in the bottom of the top groove (84, 84') after the same as been filled with filler (60). This prevents the multi-groove system (82) from crowning since

any expansion of the wood by moisture absorption at or near the bottom of the multi-groove system (82) will be taken in by the voids of the bottom grooves (86). In other words, the multi-groove system (82), because it has its top groove (84, 84') has a weak point which does not give it enough strength to cup, at least not enough strength to go against nails or staples. It does not have a tendency to crown either because the top groove (84, 84') gives the wood room to expand.

[0059] FIGS. 9, 10 show multi-ply floors (88) having a longitudinal top groove (84), a cross top groove (90) and cross bottom grooves (92) which handles expansion lengthwise. Deep bottom grooves (86) in FIG. 9 and one deep bottom groove (86) in FIG. 10 handle cupping and crowning. Cross bottom grooves (92) and the top grooves (90) provides protection against longitudinal warping. Another advantage of these multi-ply floors (88) is that the close groupings (94) of these bottom grooves (86) with the top groove (84) creates a spring like flexibility to the multiply floor (88). Spacing between bottom grooves (86) and the top groove (84) is important and is determined by the type of wood—or in the case of engineered floor, any other material—used in order to obtain the right amount of flex. These principles can be applied to any type of flooring, engineered, multi-ply, hardwood, MDF, HDF, etc. . . . Also, the filler (60) can be applied to the long sides of the planks (52) only or across the width as well. When there are three closely spaced grooves in a grouping (94) there is twice the amount of spring as when there are only two closely spaced grooves in a grouping (96).

[0060] As can be seen in FIG. 11, there can be several close groupings (96) across the width of a multi-ply floor (88) and most are confined within the inner core (98) except for grouping (100) which has a bottom groove (86) and grouping (102) which has a top groove (84) in combination, a grouping can have the entire thickness of the plank. The depth of the various grooves can also vary between groupings and within groupings so does the width and shape and alignment. Similar cuts can also be done on hardwood 14 with no ply but when using this type of multi-ply floor (88), it can farther reduce its natural expansion tendency by having cross grain plies (116) as per FIG. 12 which restrict expansion across the width since expansion of wood along the length of the grain is only 0.1% or width expansion. By having the cross grain ply on the top finished surface, a very different look to each plank can be obtained.

[0061] In any situation where there is expansion of wood, the filler (60) can be used. For example, when laying down an insert (120) in a floor (40) as shown in FIG. 13, expansion could cause a deformation, even damage to the insert (120) but by having a spacing (50) around the perimeter of the insert (120) and filling it with the special substance (60), the problem is solved.

[0062] Because of the versatility of the system described herein, whenever a reference to prior art hardwood planks (66) was made, it covered wood floors in general even if their content in real wood is very low or non existent; it is just a generic term to simplify description.

[0063] It is also understood that the intra-plank and inter-plank structures described hereinabove with respect to the floor covering can also be applied to the intermediate panels (44).

1. A flooring system comprising a number of flooring members installed next to each other in a coplanar relationship so as to define an open top inter-member gap between each adjacent pairs of flooring members, and a compressible/extensible sealing filler in said open top inter-member gap, said sealing filler being visible and accessible from above.

2. A flooring system as defined in claim 1, wherein a stopper is provided in said open-top inter-member gap below said sealing filler to prevent excessive compression thereof as a result of an expansion of said flooring members.

3. A flooring system as defined in claim 1, wherein said flooring members have respective top surfaces defining a floor surface, and wherein said sealing filler and said open top inter-member gap cooperate together to define a concavity so that dust and sand on said floor surface can be pushed in said concavity to prevent scratching of said floor surface.

4. A flooring system as defined in claim 2, wherein longitudinal grooves are defined in the opposed facing sides of said pairs of adjacent flooring members, and wherein a T-shaped spline is engaged with said longitudinal grooves to bridge each pair of adjacent flooring members, said T-shaped spline having a stem extending vertically in said open top inter-member gap, said stem acting as said stopper to limit the expansion of said flooring members into said open top inter-member gap.

5. A flooring system as defined in claim 1, wherein said filler stretch or compress to at least 50% of its size.

6. A flooring system as defined in claim 1, wherein a stopper prevents closing of the open top end of the inter-member groove as a result of an expansion of said flooring members.

7. A flooring system as defined in claim 1, wherein at least some of said flooring members are provided with internal expansion/contraction accommodation means to provide for local absorption of floor expansion and contraction movements and prevent chain transmission of stresses from one plank to another, said internal expansion/contraction accommodation means comprising at least one top groove defined in a top surface of said flooring members.

8. A flooring system as defined in claim 7, wherein said top groove extends all along the length of the platform and mimics an inter-plank joint between two side-by-side planks.

9. A flooring system as defined in claim 7, wherein said top groove is also filled with said sealing filler.

10. A flooring system as defined in claim 7, wherein said internal expansion/contraction accommodation means further include at least one bottom groove defined in a bottom surface of said at least some of said flooring members.

11. A flooring system as defined in claim 10, wherein said at least one bottom groove is laterally offset from said top groove of a same flooring member, and wherein said top and bottom grooves vertically overlaps each others.

12. A flooring system as defined in claim 1, wherein a floating interlocking joint is provided between adjacent flooring members, said floating interlocking joint comprising a locking key extending from one side of a first flooring member and engageable with a complementary locking groove provided in an opposed facing side of a second flooring member, said locking key having a limited freedom of movement within said locking groove in a direction

perpendicular to said opposed facing sides to accommodate expansion and contraction movements of said first and second flooring members.

13. A flooring system as defined in claim 12, wherein said locking groove has a locking tab projection for locking engagement with said locking key, and wherein when said locking key is engaged behind said locking groove and abutted thereagainst, a play is defined between the locking key and an end wall of the locking groove.

14. A flooring system comprising first and second flooring members adapted to be laid down side-by-side in a coplanar relationship, and a floating interlocking joint between said first and second flooring members, said floating interlocking joint comprising a compressible/stretchable filler provided in a gap between opposed facing sides of said first and second flooring members said filler being adhesively engaged with said opposed facing sides, and a locking key provided on a first one of said opposed facing sides and engageable with a complementary locking groove provided in a second one of said opposed facing sides, said locking key having a limited freedom of movement within said locking groove in a direction perpendicular to said opposed facing sides to accommodate expansion and contraction movements of said first and second flooring members.

15. A flooring system as defined in claim 14, wherein said locking groove has a locking tab projection for locking engagement with said locking key, and wherein when said locking key is engaged behind said locking groove and abutted thereagainst, a play is defined between the locking key and an end wall of the locking groove.

16. A floor plank adapted to be laid in a side-by-side coplanar relationship with similar floor planks to form a floor surface, said floor plank comprising an internal expansion/contraction accommodation means to provide for local absorption of floor expansion and contraction movements and prevent chain transmission of stresses from one plank to another, said internal expansion/contraction accommodation means comprising at least one top groove defined in an exposed top surface of said floor plank.

17. A floor plank as defined in claim 16, wherein said top groove extends all along the length of the platform and mimics an inter-plank joint between two side-by-side planks.

18. A floor plank as defined in claim 16, wherein compressible/extensible filler is provided in said top groove.

19. A floor plank as defined in claim 16, wherein said internal expansion/contraction accommodation means fur-

ther include a bottom groove defined in a bottom surface of said floor plank, said bottom groove being in substantially vertical alignment with said top groove.

20. A floor plank(as defined in claim 16, wherein said internal expansion/contraction accommodation means further include a bottom groove defined in a bottom surface of said floor plank, said bottom groove being laterally offset from said top groove, and wherein said top and bottom grooves vertically overlaps each others.

21. A floor plank as defined in claim 16, wherein said top groove extends generally longitudinally of said floor plank, and wherein said internal expansion/contraction accommodation means further include a transversally extending groove.

22. A floor plank as defined in claim 16, wherein said internal expansion/contraction accommodation means further include a plurality of spaced-apart grooves having at least one of a different depth, width, shaped and orientation.

23. A flooring member adapted to be laid in a side-by-side coplanar relationship with similar floor planks to form a substantially level surface, said flooring member having a bottom surface, a series of grooves defined in said bottom surface, and wherein at least one of said grooves is filled with a filling material having adhesive properties.

24. A flooring member as defined in claim 23, wherein said grooves are arranged side-by-side, and wherein a central one of said groove is deeper than the other grooves.

25. A flooring member as defined in claim 23, wherein said at least one groove in which the filling material is provided is deeper than the other grooves.

26. A flooring member as defined in claim 23, wherein excess filling material is allowed to flow from said at least one groove to other adjacent grooves.

27. A flooring system comprising first and second flooring members adapted to be laid down side-by-side in a coplanar relationship, and an interlocking joint between said first and second flooring members, said interlocking joint comprising a compressible/stretchable filler provided in a gap between opposed facing sides of said first and second flooring members, said filler being adhesively engaged with said opposed facing sides and retaining said first and second flooring members together in an assembled relationship, and a locking key provided on a first one of said opposed facing sides and engageable with a complementary locking groove provided in a second one of said opposed facing sides.

* * * * *