



US00D916535S

(12) **United States Design Patent**  
**Mortensen et al.**

(10) **Patent No.:** **US D916,535 S**

(45) **Date of Patent:** **\*\* Apr. 20, 2021**

- (54) **WAND STAND**
- (71) Applicant: **Bold Plastics Incorporated**, West Jordan, UT (US)
- (72) Inventors: **Kenneth Lee Mortensen**, Sandy, UT (US); **Ernest Jensen**, West Jordan, UT (US); **Andrew Thomas Despain**, Riverton, UT (US)
- (73) Assignee: **Bold Plastics Incorporated**, West Jordan, UT (US)

D719,142 S *	12/2014	Lee .....	D14/239
D755,796 S *	5/2016	Gibson .....	D14/447
D759,659 S *	6/2016	Lee .....	D14/451
D840,996 S *	2/2019	Lambert .....	D14/253
D872,300 S *	1/2020	Demsia .....	D24/227
D878,120 S *	3/2020	Smith .....	D6/682.1

\* cited by examiner

*Primary Examiner* — Mark Booker

(74) *Attorney, Agent, or Firm* — Workman Nydegger

(\*\*) Term: **15 Years**

(57) **CLAIM**

(21) Appl. No.: **29/688,648**

The ornamental design for a wand stand, as shown and described.

(22) Filed: **Apr. 23, 2019**

(51) **LOC (13) Cl.** ..... **06-04**

(52) **U.S. Cl.**  
USPC ..... **D6/672**

**DESCRIPTION**

(58) **Field of Classification Search**  
 USPC ..... D6/513, 525, 514, 553, 567, 527, 672, D6/682.1; D19/86, 87, 88, 89, 90, 91, D19/92; D24/107, 121, 133, 216, 222, D24/227-230; 206/6.1, 37, 557, 561, 206/564, 566; 211/88, 113, 126, 134; D13/107; D14/239, 253, 447, 451  
 CPC ..... B01L 9/00; B01L 9/54; Y10T 403/346  
 See application file for complete search history.

FIG. 1 is a front perspective view of a wand stand showing the new design;  
 FIG. 2 is a front elevation view thereof;  
 FIG. 3 is a back elevation view thereof;  
 FIG. 4 is a top plan view thereof;  
 FIG. 5 is a bottom plan view thereof;  
 FIG. 6 is a right elevation view thereof; and,  
 FIG. 7 is a left elevation view thereof.

The broken lines illustrate portions of the wand stand and form no part of the claimed design.

(56) **References Cited**

**U.S. PATENT DOCUMENTS**

D363,180 S *	10/1995	Carter .....	D6/513
D693,607 S *	11/2013	Johnson .....	D6/672
D716,870 S *	11/2014	Jungst .....	D19/91

**1 Claim, 3 Drawing Sheets**

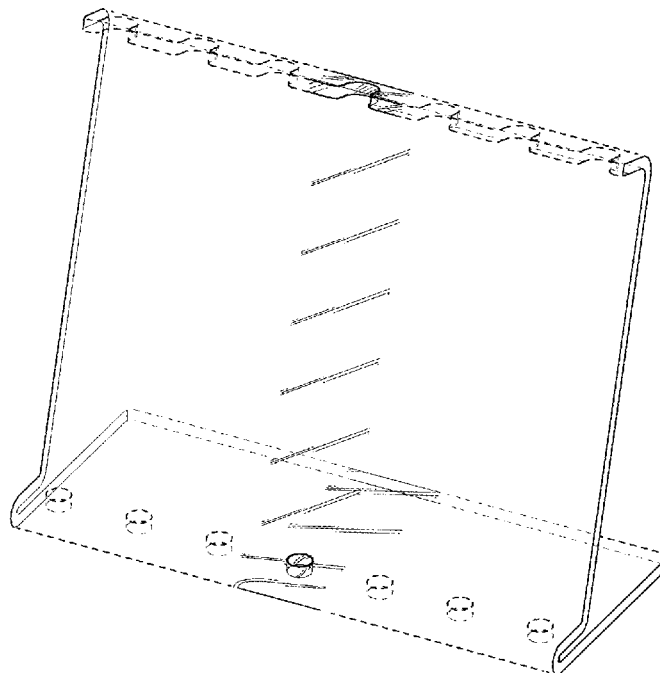

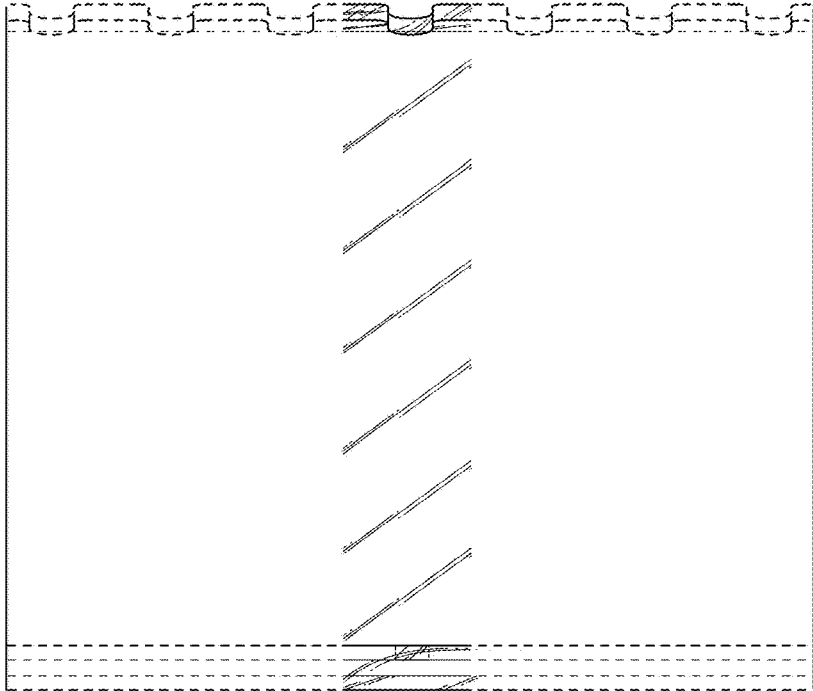
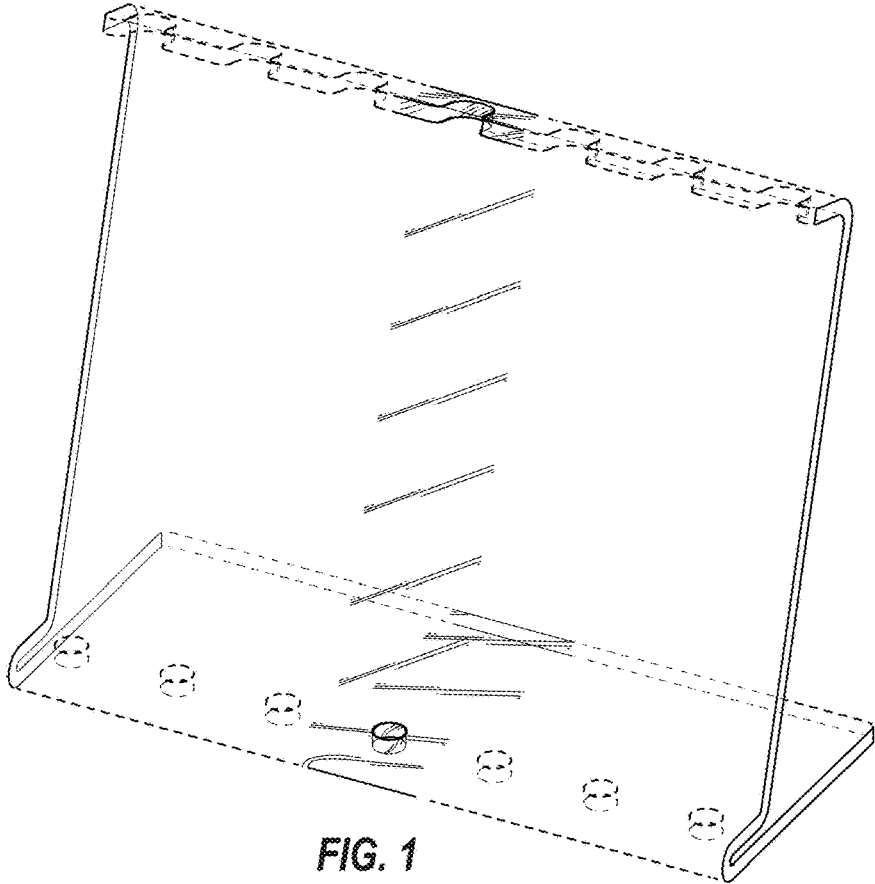

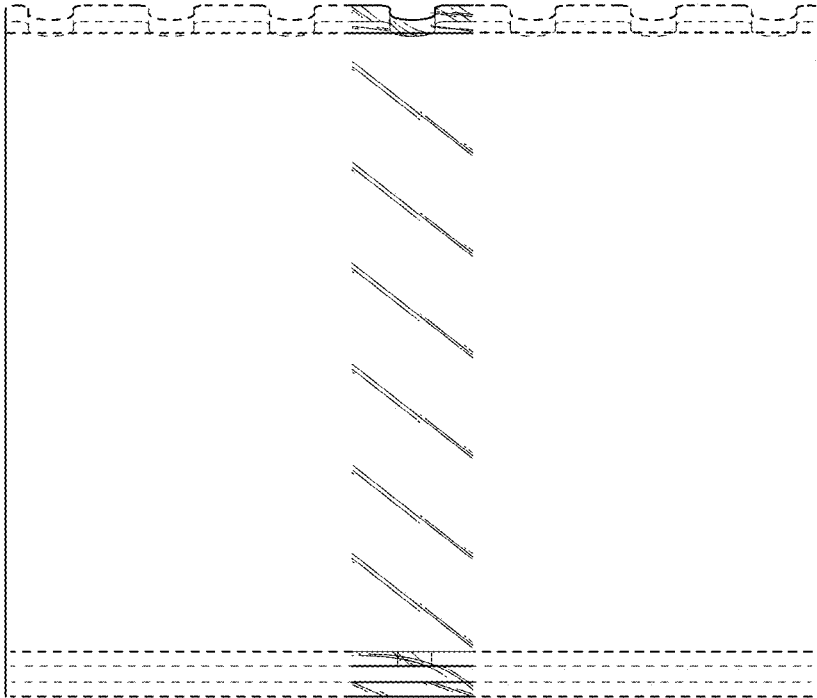

FIG. 3

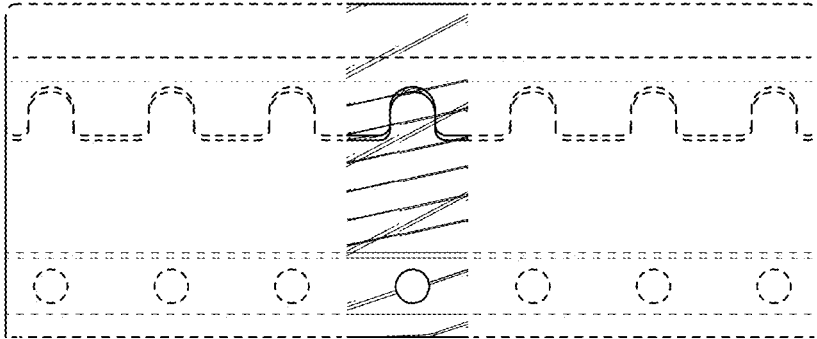

FIG. 4

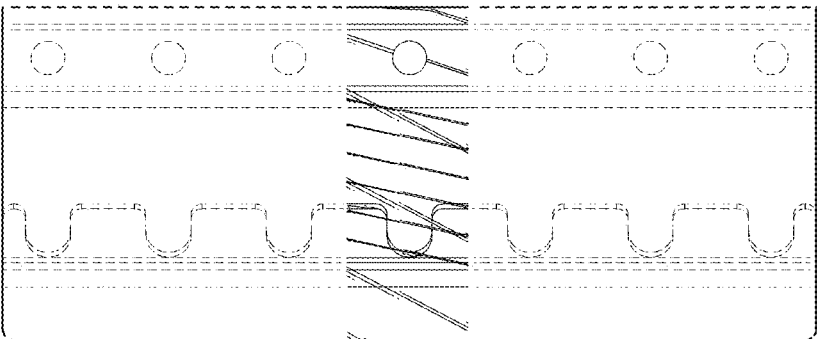

FIG. 5

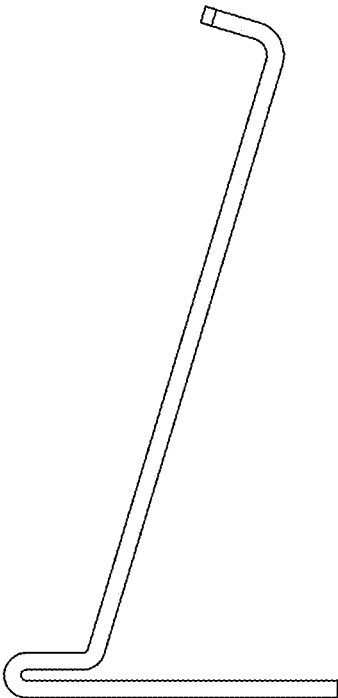

FIG. 6

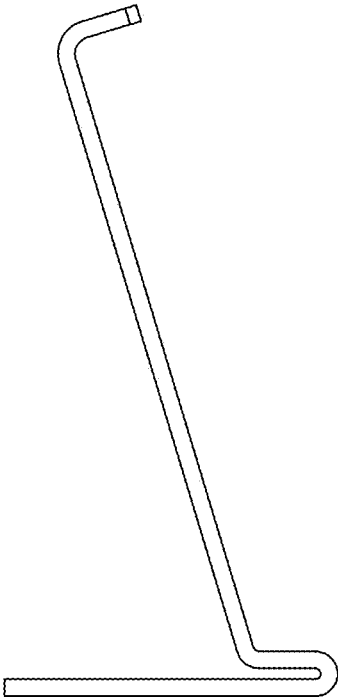

FIG. 7