



US00D899468S

(12) **United States Design Patent**
Behn et al.

(10) **Patent No.:** **US D899,468 S**

(45) **Date of Patent:** **** Oct. 20, 2020**

- (54) **VIBRATORY ROLLER**
- (71) Applicant: **CATERPILLAR PAVING PRODUCTS INC.**, Brooklyn Park, MN (US)
- (72) Inventors: **Mark D. Behn**, St. Michael, MN (US); **Brian Nagel**, Ramsey, MN (US); **Terril Johnson**, Washington, IL (US); **Robert Iverson**, Maple Grove, MN (US); **Andrew R. Torkelson**, New Hope, MN (US)
- (73) Assignee: **Caterpillar Paving Products Inc.**, Brooklyn Park, MN (US)

D668,269	S	*	10/2012	Tezuka	D15/20
D668,694	S	*	10/2012	Tezuka	D15/31
D676,463	S	*	2/2013	Ewringmann	D15/20
D694,278	S	*	11/2013	Ewringmann	D15/20
D694,279	S	*	11/2013	Ewringmann	D15/20
D699,764	S	*	2/2014	Loew	D15/20
D720,779	S	*	1/2015	Loew	D15/20
D744,543	S	*	12/2015	Loew	D15/20
D745,063	S	*	12/2015	Loew	D15/20
D765,735	S	*	9/2016	Roemer	D15/20
D796,557	S	*	9/2017	Loew	D15/20
D800,792	S	*	10/2017	Loew	D15/20
D800,793	S	*	10/2017	Loew	D15/20
D819,704	S	*	6/2018	Loew	D15/20
D853,450	S	*	7/2019	Loew	D15/20
2004/0028472	A1	*	2/2004	Richter	E01C 19/286
						404/117
2012/0114416	A1	*	5/2012	Marsolek	E01C 19/286
						404/75

(**) Term: **15 Years**

(Continued)

(21) Appl. No.: **29/691,256**

Primary Examiner — Mark A Goodwin

(22) Filed: **May 15, 2019**

(57) **CLAIM**

(51) **LOC (12) Cl.** **15-03**
(52) **U.S. Cl.**

The ornamental design for a vibratory roller, as shown and described.

USPC **D15/20**

(58) **Field of Classification Search**
 USPC D15/10, 20, 22-26, 28, 30, 33; 180/20, 180/89.12; 280/104, 124.11; 404/122, 404/132, 125, 90
 CPC E02D 3/026; E02D 3/00; E02D 3/074; B30B 15/00; E01C 19/27; E01C 19/41; E01C 19/22; E01C 19/38; E01C 19/286; E01C 19/4853; E01C 19/238
 See application file for complete search history.

DESCRIPTION

FIG. 1 is a front, top, left perspective view of a vibratory roller showing the new design;
 FIG. 2 is a rear, top, right perspective view thereof;
 FIG. 3 is a rear, bottom, left perspective view thereof;
 FIG. 4 is a front elevation view thereof;
 FIG. 5 is a rear elevation view thereof;
 FIG. 6 is a left side view thereof;
 FIG. 7 is a right side view thereof;
 FIG. 8 is a top plan view thereof; and,
 FIG. 9 is a bottom plan view thereof.
 The broken lines of even length shown in the drawings illustrate portions of the vibratory roller that form no part of the claimed design.

(56) **References Cited**
 U.S. PATENT DOCUMENTS

D396,431	S	*	7/1998	Lindgren	D12/14
D516,094	S	*	2/2006	Dotsch	D15/20
D611,505	S	*	3/2010	Loew	D15/20
D611,506	S	*	3/2010	Loew	D15/20

1 Claim, 9 Drawing Sheets

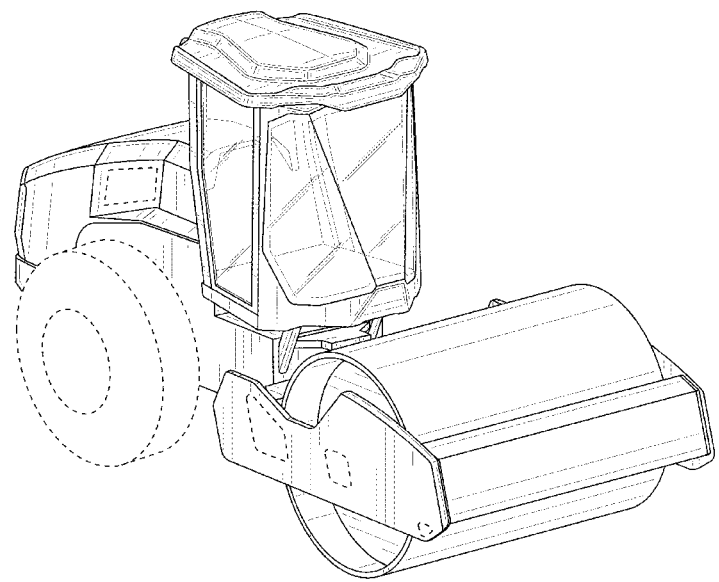

(56)

References Cited

U.S. PATENT DOCUMENTS

2012/0301221	A1*	11/2012	Ackermann	E01C 19/282 404/75
2014/0161529	A1*	6/2014	Darscheid	E01C 19/38 404/84.05
2015/0204031	A1*	7/2015	Kreutz	E01C 19/12 404/103

* cited by examiner

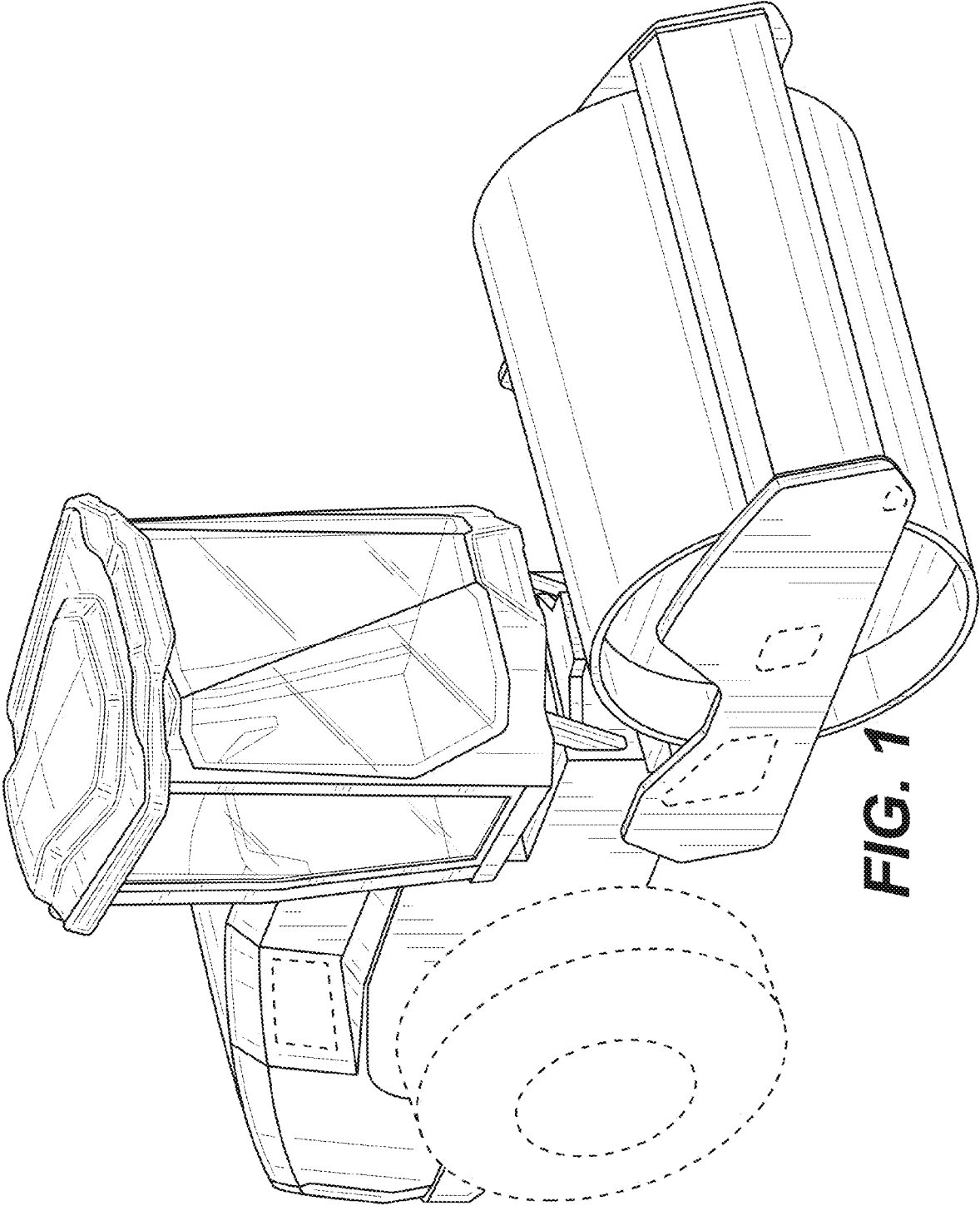

FIG. 1

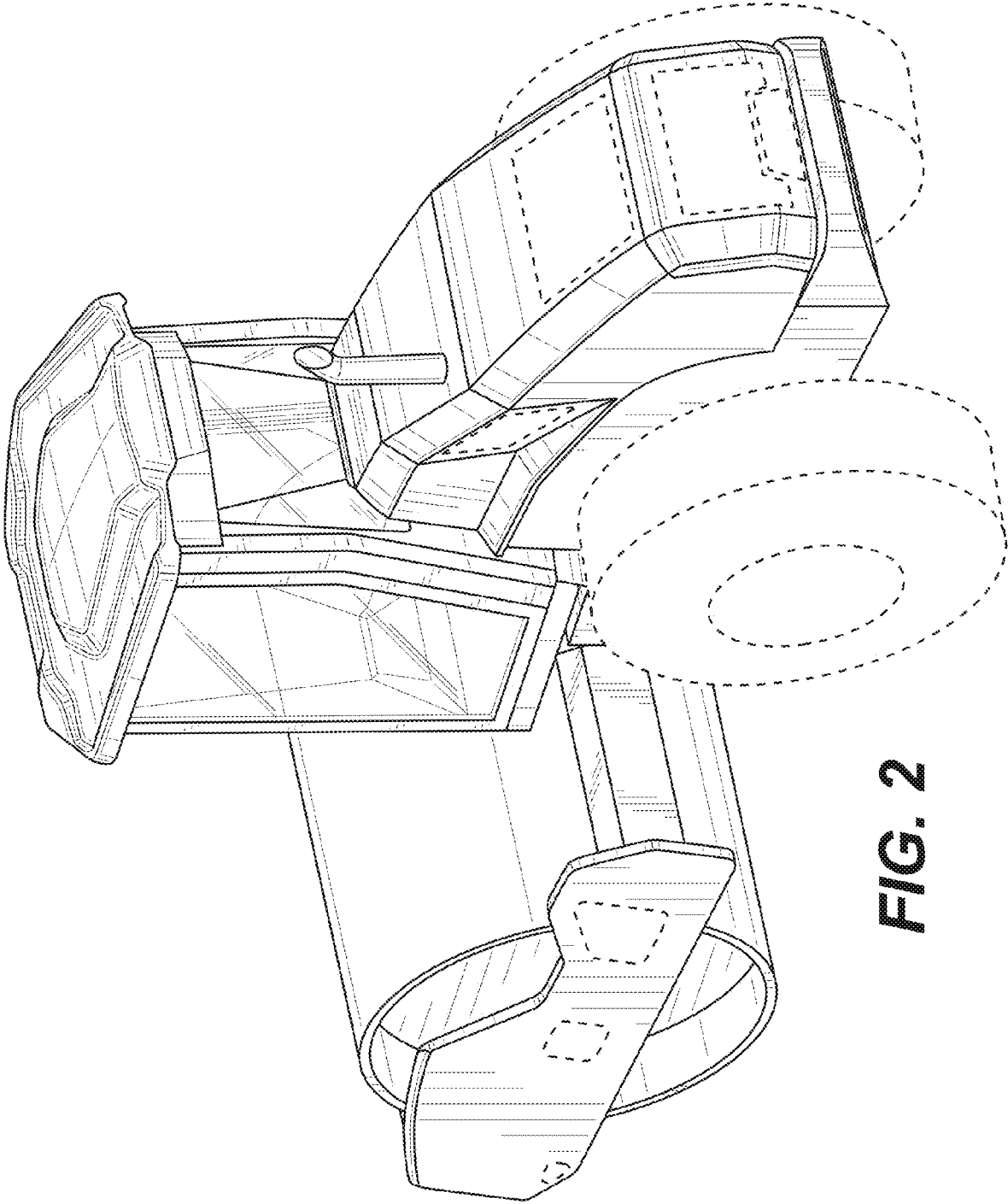

FIG. 2

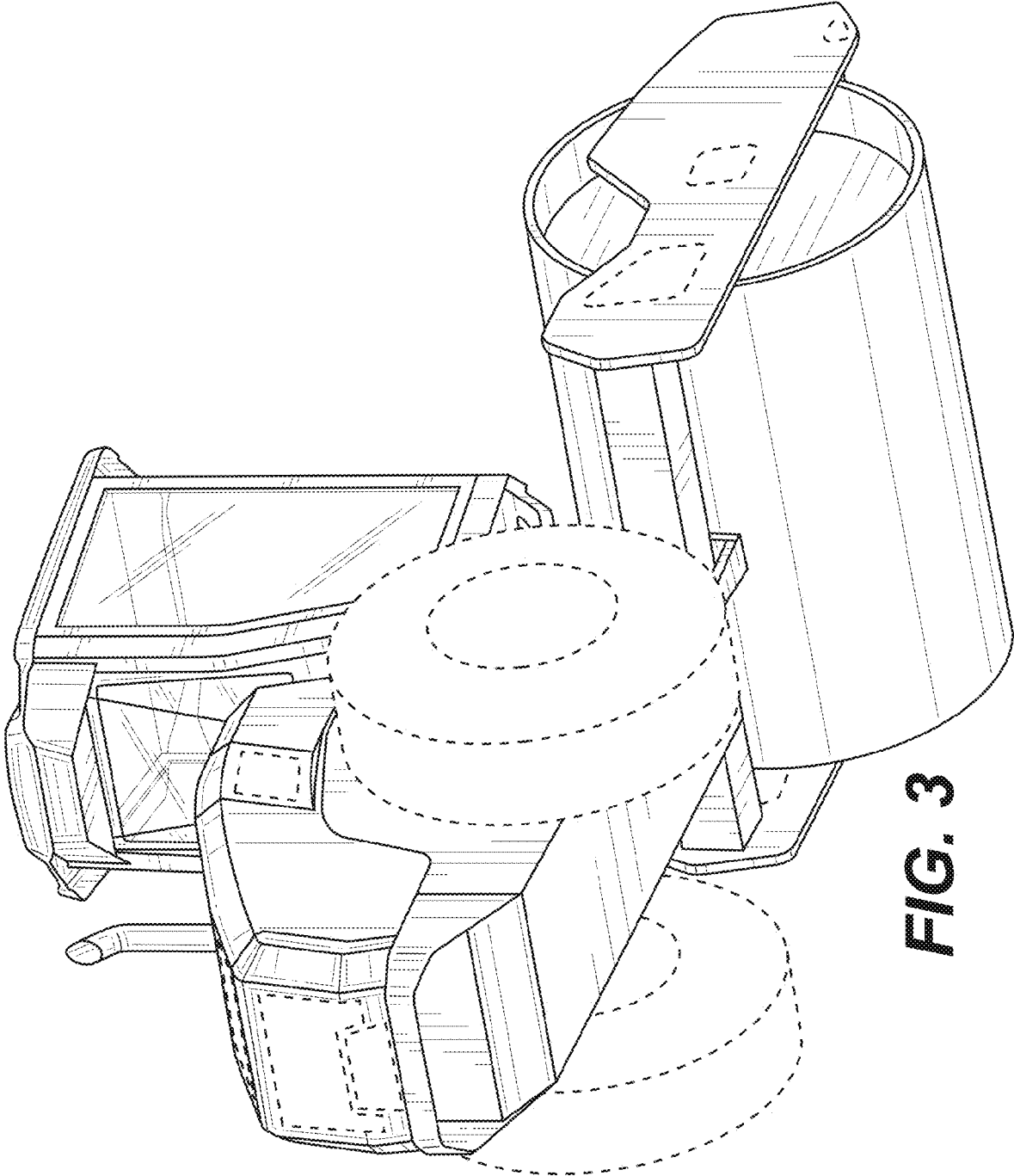

FIG. 3

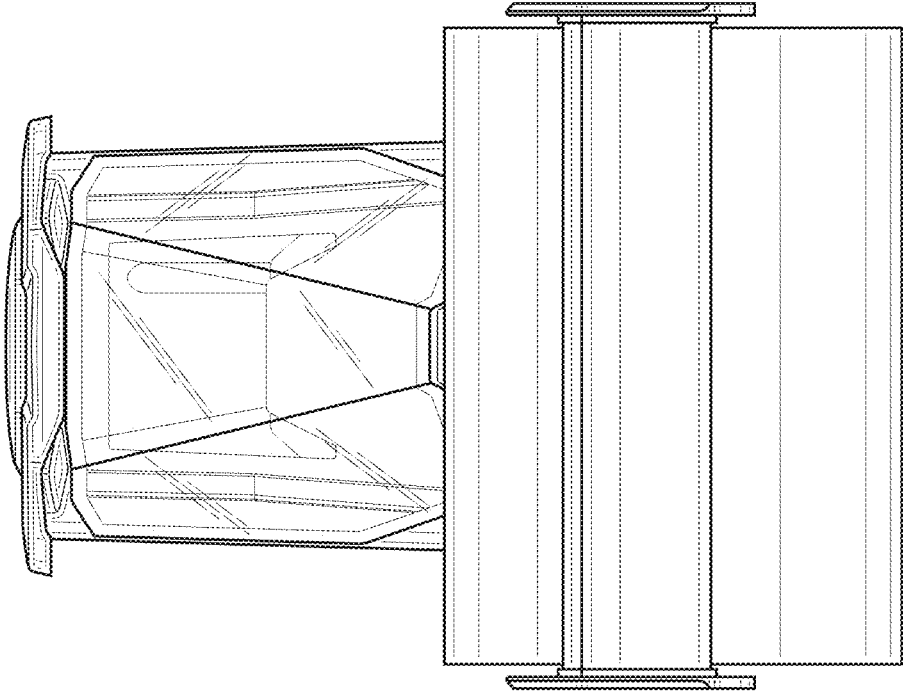

FIG. 4

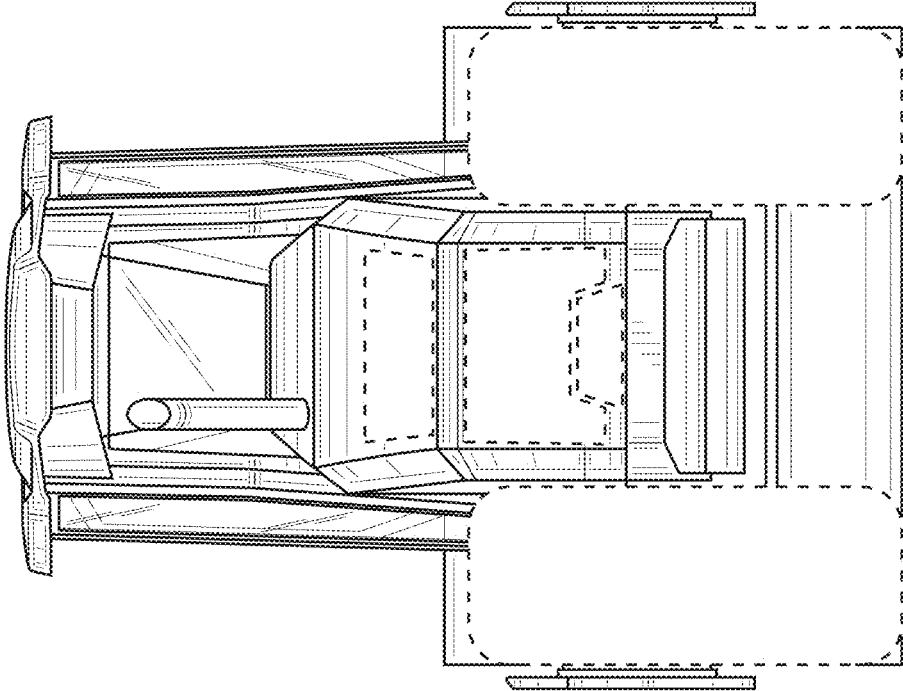

FIG. 5

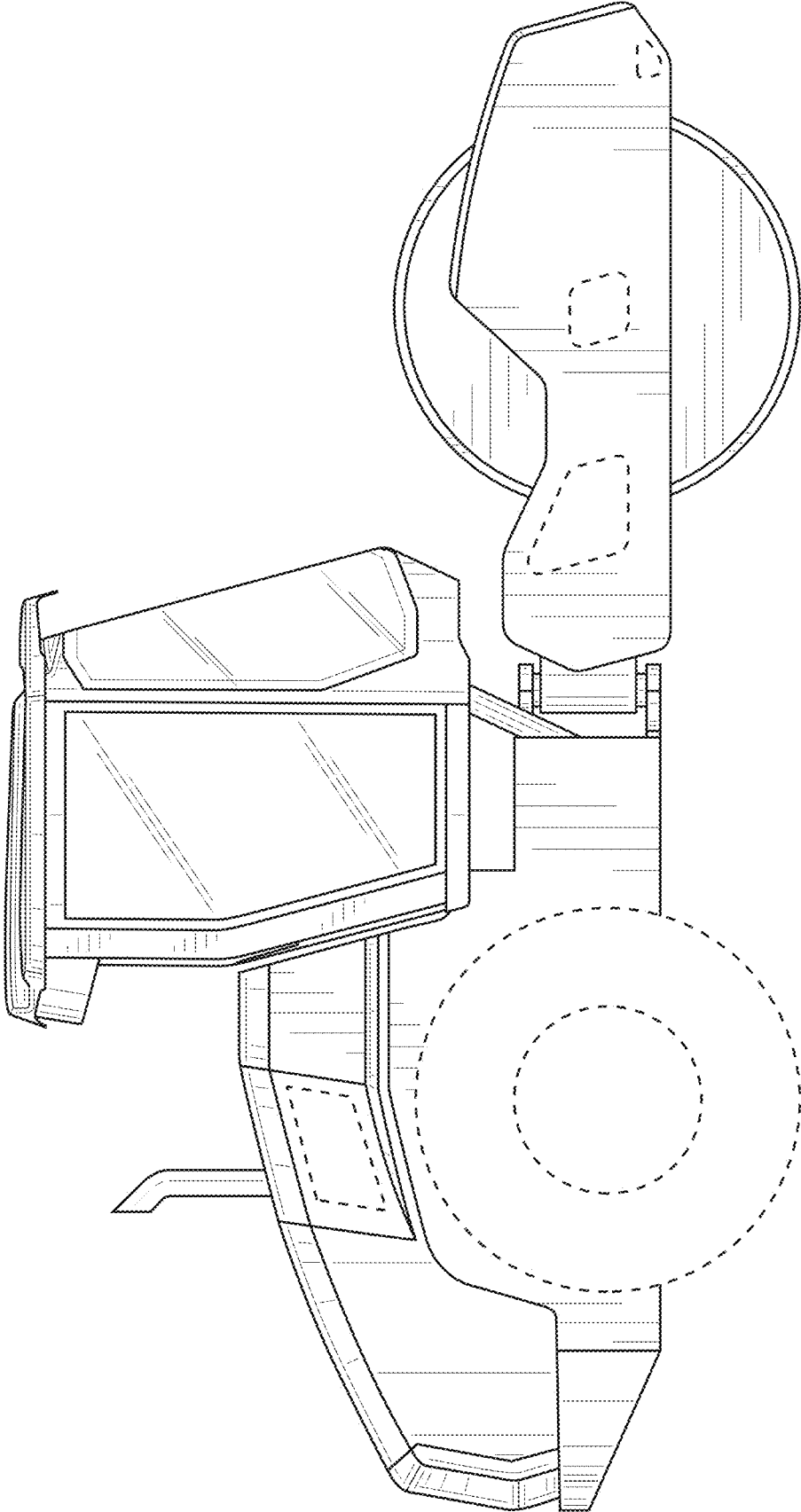

FIG. 6

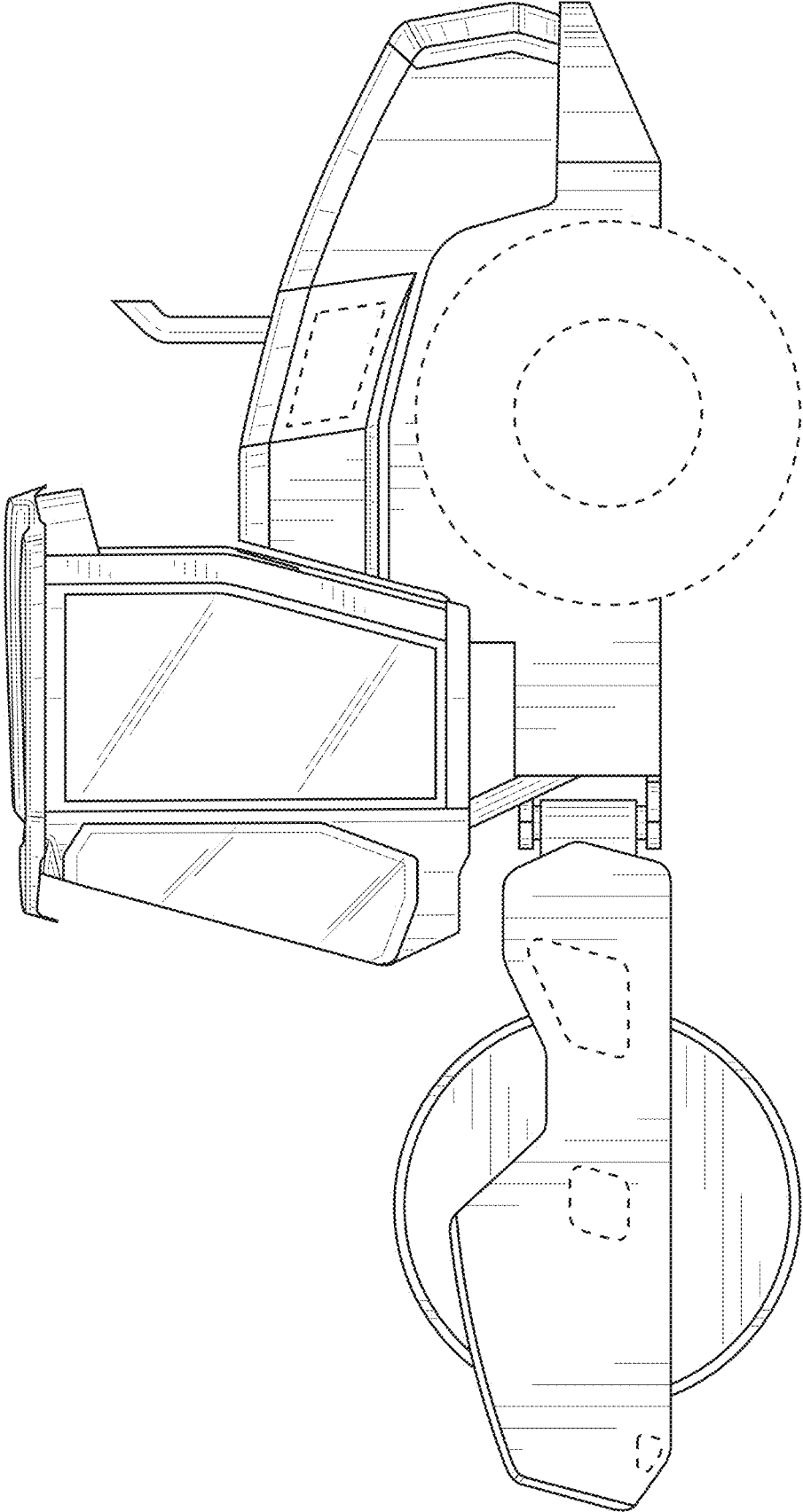

FIG. 7

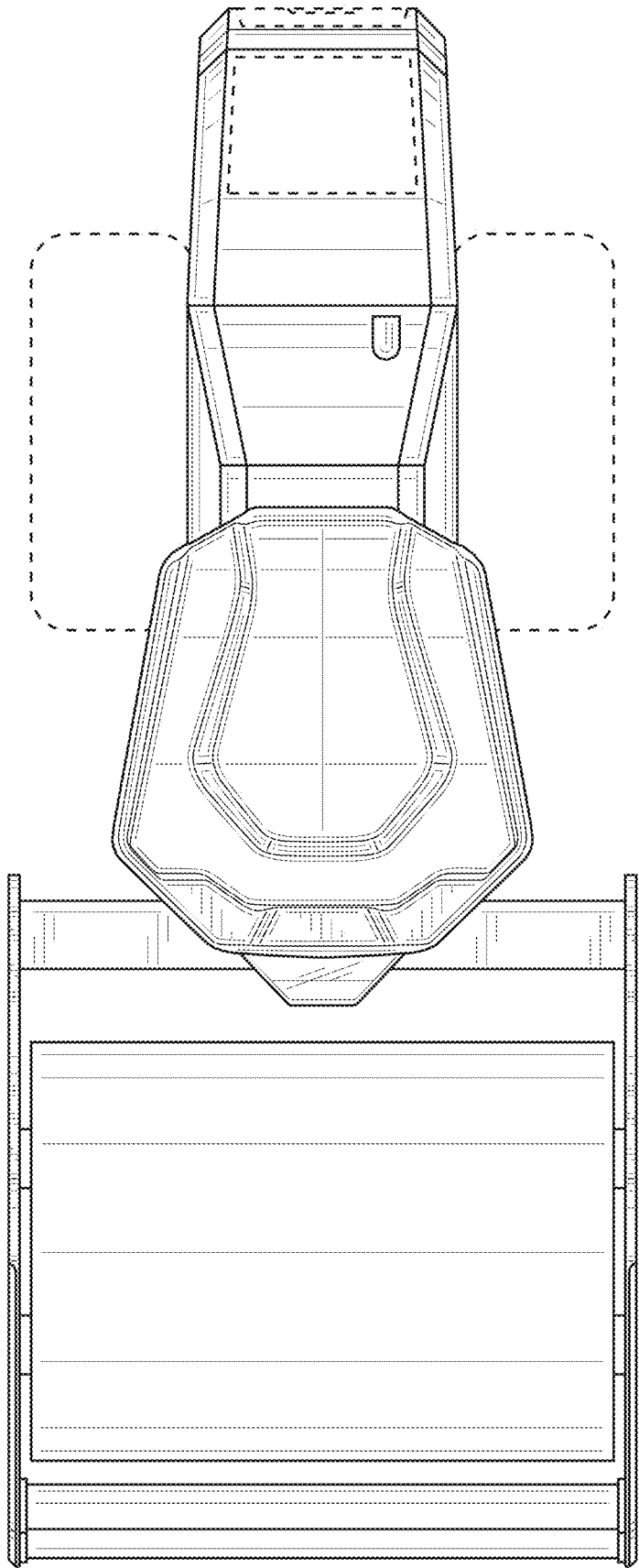

FIG. 8

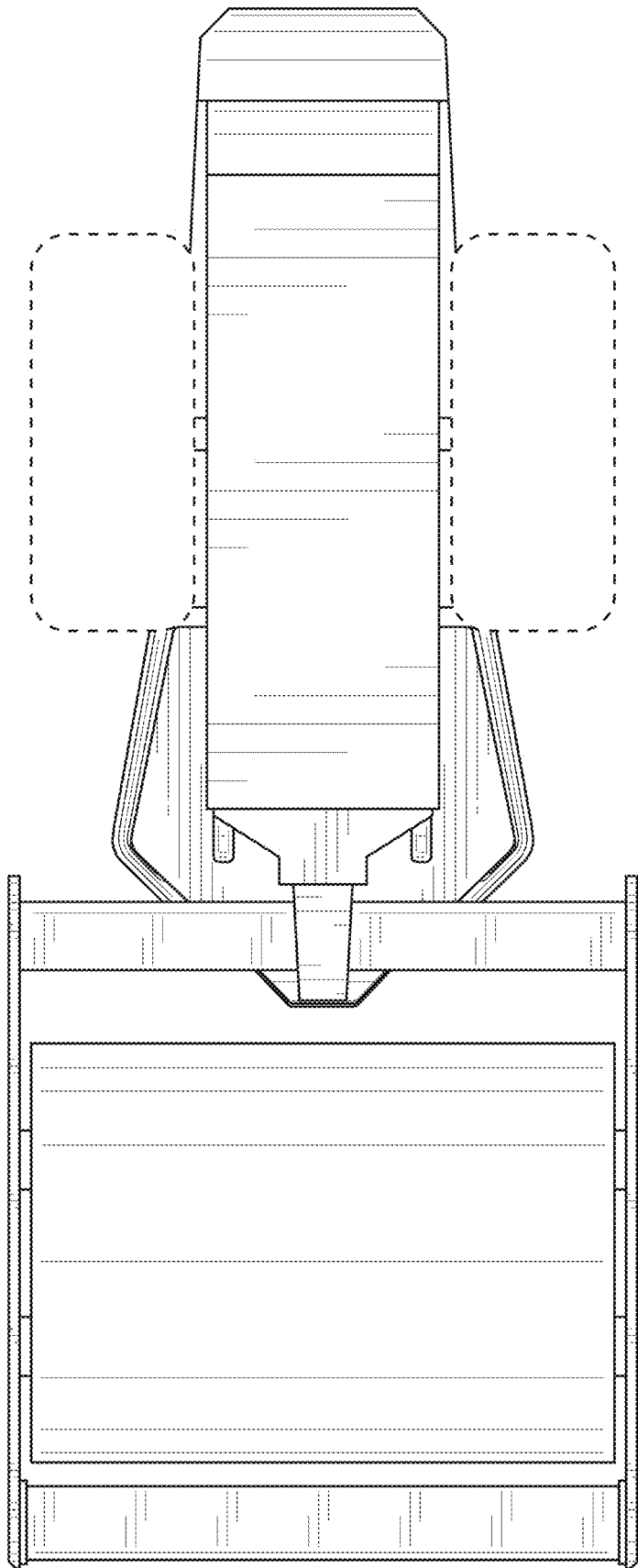

FIG. 9