

[54] **GARMENT MAKER'S MANNEQUIN**
 [76] Inventor: **George Cavrich**, 1285 Madison Ave., New York, N.Y. 10028
 [22] Filed: **Sept. 17, 1973**
 [21] Appl. No.: **397,801**

2,657,843 11/1953 Weisner 223/68
 2,779,520 1/1957 Sykes 223/68
 2,874,883 2/1959 Stoddard 223/68
 2,880,917 4/1959 Pancari 223/68
 3,010,225 11/1961 Hale 223/66 X
 3,472,435 10/1969 Mazz 223/68

Related U.S. Application Data

[62] Division of Ser. No. 245,131, April 18, 1972, abandoned.

Primary Examiner—Geo. V. Larkin
Attorney, Agent, or Firm—Richard L. Cannaday

[52] **U.S. Cl.** **223/68**
 [51] **Int. Cl.** **A41h 5/00**
 [58] **Field of Search** 223/66, 68, 70, 72, 73, 223/67; 2/73, 74, 216, 217; 33/15, 17 R

[57] **ABSTRACT**

A flexible garment pattern is formed from a self-supporting plastic shell initially placed on a mannequin. The shell is cut while draped on the mannequin to the desired style and shape and then separated into several pieces of three-dimensional shape. These pieces are used as pattern pieces to cut out fabric pieces for a garment.

The mannequin is provided with an adjustable fit plate in the bustline and kicker plates in the leg portion to impart a desired silhouette to the shaped shell.

[56] **References Cited**

UNITED STATES PATENTS

2,273,743 2/1942 Weinstein 223/68
 2,284,965 6/1942 Palmer et al. 223/68
 2,533,906 12/1950 Akers 223/68
 2,551,613 5/1951 Litchfield 223/68
 2,620,099 12/1952 Laikauf 223/68

3 Claims, 7 Drawing Figures

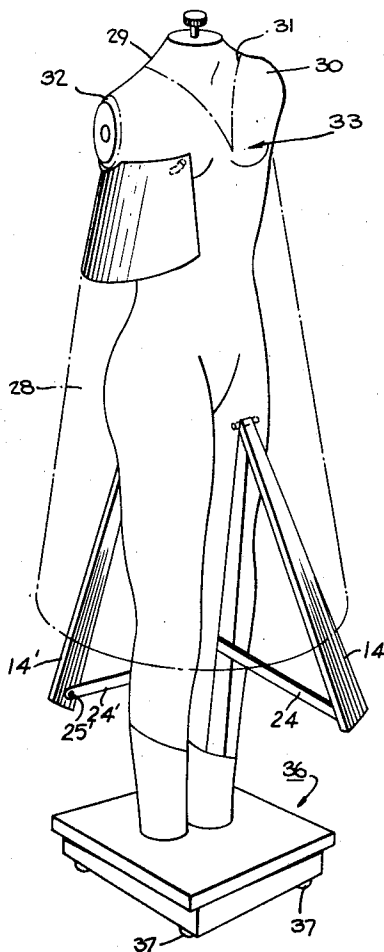

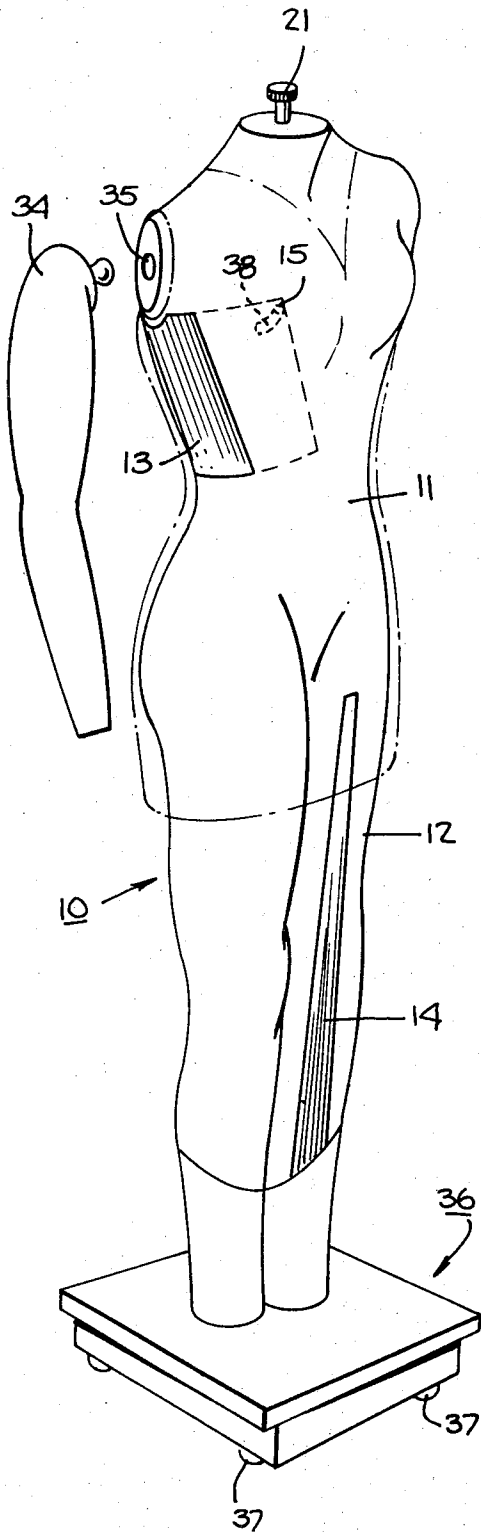

Fig. 1.

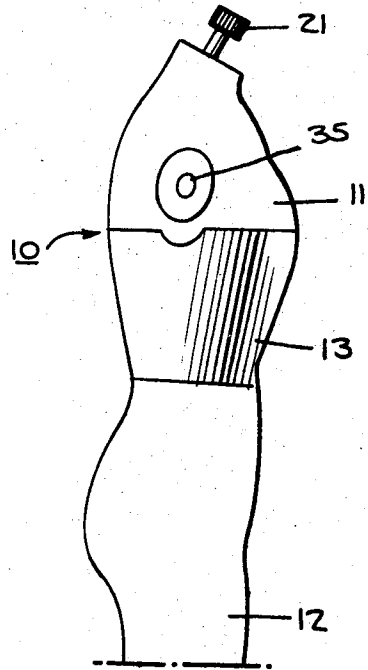
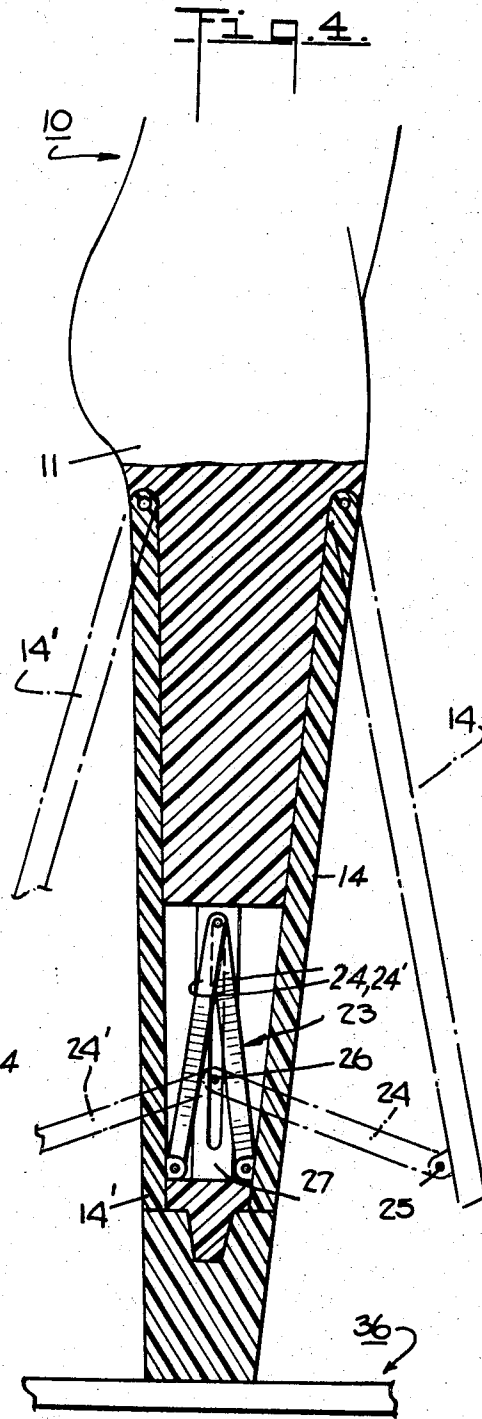
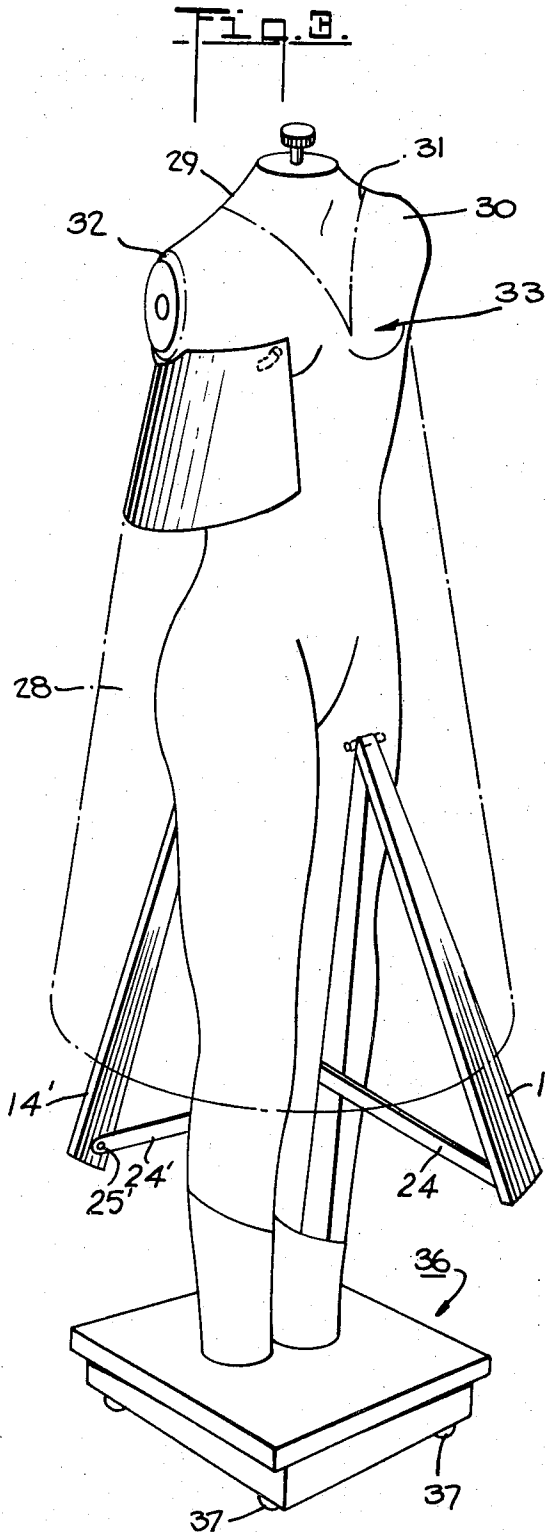
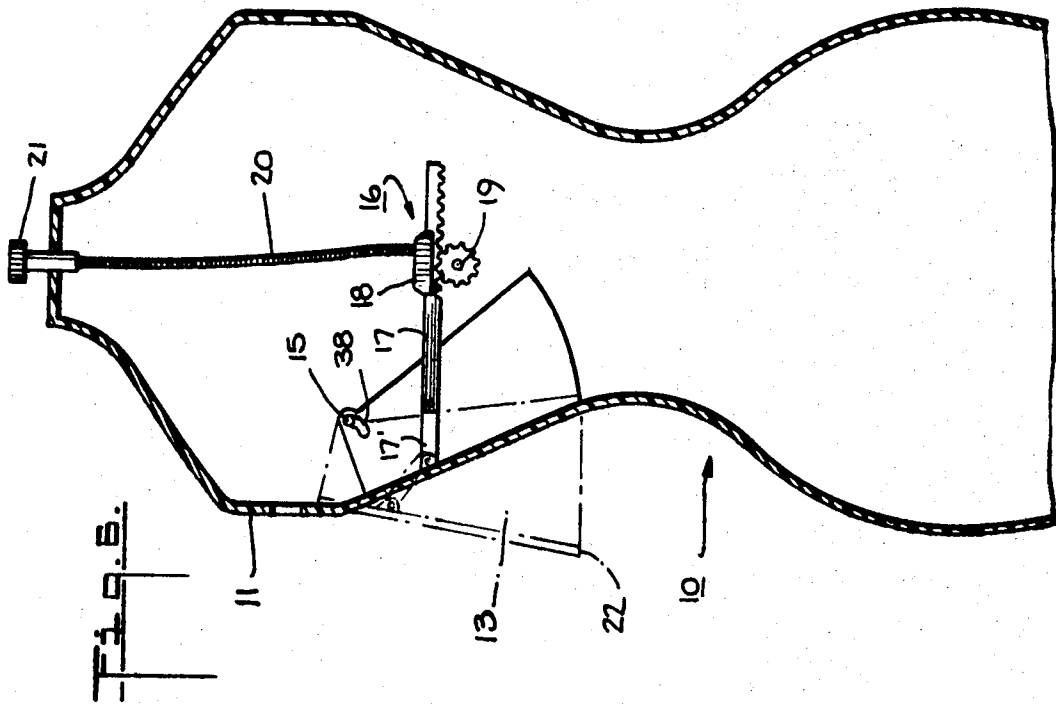
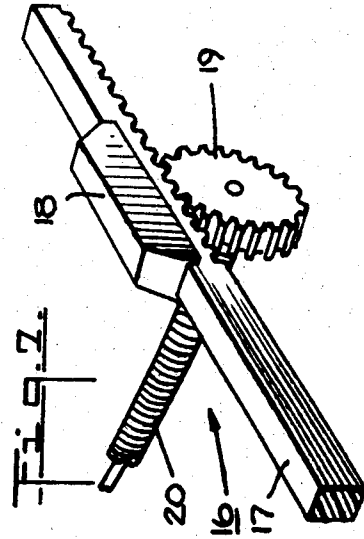
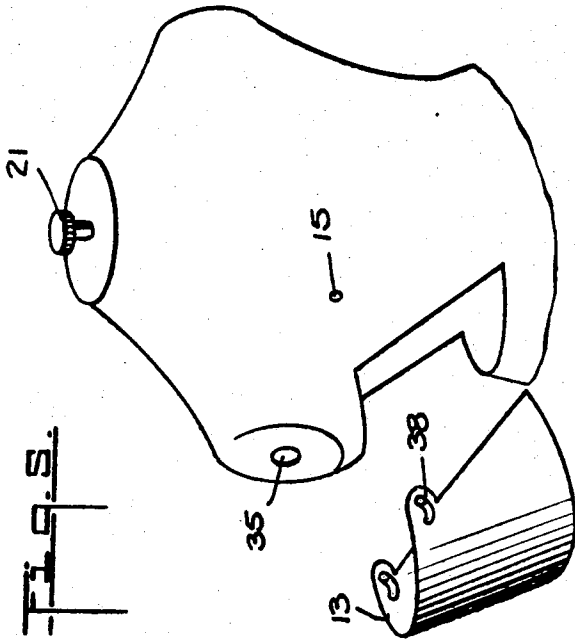

Fig. 2.





GARMENT MAKER'S MANNEQUIN**CROSS-REFERENCE TO RELATED APPLICATION**

This application is a division of my co-pending U.S. Pat. application Ser. No. 245,131, filed in the U.S. Pat. Office on Apr. 18, 1972 and now abandoned.

BACKGROUND OF THE INVENTION

This invention relates to a method, and apparatus for developing a garment pattern. Still more particularly, this invention relates to a flexible garment pattern of three-dimensional shape.

Heretofore it has been known in the making of a garment, such as a dress, to form the garment from a predetermined pattern. In this regard the pattern has been used as a guide for the cutting of pieces of fabric of various sizes and shapes from a bolt of fabric. The cut pieces are thereafter sewn together in a suitable sequence to form the garment desired.

Generally the patterns which have been used have been developed from a mannequin or directly from a model. For example, in order to prepare a pattern for a particular garment such as a dress, it has been known to drape large pieces of material over a mannequin and to pin the pieces in various places so as to take on a particular style for the contour of the mannequin. Thereafter the material is cut at appropriate places where seams are desired and suitable places for tucks or darts are indicated. The various pieces of material are then sewn together into a fitting of said material and placed on the mannequin for further adjustments. Once the garment has been properly fitted, the various pieces of the garment are then separated and a pattern is made from these pieces.

It has also been known to have a pattern maker sketch the pattern pieces required for a garment without specific reference to a mannequin or model. The sketches are then used to obtain pieces of material which are thereafter pinned together on a model to determine the final fitting.

In both of these above instances considerable time and effort is required since the master pattern is not made directly from the mannequin in one step. Instead, it has been necessary to fit the master pattern onto the mannequin at least once more to obtain final adjustments.

Further, once the master pattern has been completed, it has been necessary to separate the pattern into pieces for cutting subsequent pieces of cloth for the garment to be joined. As the pieces are of cloth, such requires care to ensure that each pattern piece lays flat without wrinkling during a cutting operation of one or more dozen layers of cloth from the pattern piece.

Also, in some instances, in order for a garment maker to make patterns from different styles a number of mannequins have been used each of which corresponds to a particular style. This, however, requires additional expense due not only to the purchase price of the mannequin but also to the space required for storage.

SUMMARY OF THE INVENTION

Briefly, the invention relates to a method of making a flexible, pliable garment maker's pattern. The method employs a mannequin and a self-supporting

plastic shell which fits loosely over the mannequin and is supported at the bust, shoulder, shoulder blade and high point of the back of the mannequin. In order to make the pattern the plastic shell is initially placed over the mannequin, and is thereafter cut by a pattern maker by means of a suitable instrument such as a heated knife and shaped to the particular style garment desired while excess material is removed. After the cutting operation has been completed the shell is separated into a number of pieces that form a three-dimensional shape. These pieces form the developed flexible contour pattern pieces of the invention.

In order to duplicate the pattern, each pattern piece, where necessary, is slit at various edges so as to be flattened. The slits which are made in the pattern pieces open into V-shaped notches when the piece is flattened and correspond to the darts or tucks which are to be made for a garment. The pieces are then placed over a plurality of layers of fabric, e.g. a gross of layers, and flattened. A suitable cutting tool such as an electric saw is then guided around the flattened pattern to cut the stacked fabric. In this respect the fabric is cut with a sufficient margin to provide for seams. After the respective stacks of fabric are cut the fabric pieces are sewn into garments.

In order to provide one mannequin for any desired style, an adjustable fit plate is mounted in an upper portion about the bustline so as to be moved inwardly or outwardly of the mannequin to effect different contours dependent on the style of garment desired. This fit plate can be adjusted manually by suitable adjusting means in the mannequin. The adjusting means for adjusting the position of the fit plate is mounted within the upper half of the mannequin and is connected to the adjustable fit plate so as to pivot the plate relative to the remainder of the mannequin. The adjustment is controlled by a suitable mechanism situated atop of the uppermost portion of a mannequin. In addition, the mannequin has a pair of kicker plates adjustably mounted in respective leg portions of the mannequin corresponding to the legs of a garment wearer. These kicker plates are used to establish the stride of the wearer. These kicker plates can be adjusted independently of each other or can be adjusted in unison with each other. The kicker plates can be manually actuated since they would generally be accessible when the shell is in place.

It is noted that the fit plate in the bustline of the mannequin provides for a change in the silhouette of the garment to be designed. For example, by fully extending the fit plate outwardly of the mannequin a silhouette for a straight drape garment is provided. In the full retracted position a silhouette for a form-fitting garment is provided. Of course any particular silhouette can be obtained with any other, intermediate position of the fit plate.

The plastic shell of the invention is of hollow construction and is provided with neck and arm holes. The shell is contoured to any suitable shape such as conical or a substantially cylindrical shape. In addition, the shell is contoured in the bustline, shoulder and back areas to more accurately fit to the mannequin. Also, the shell is provided with horizontal and vertical graduations which serve to align the various pieces cut from the shell. In use, the shell is positioned over the mannequin in a fully draped fashion and rests on the shoulder,

bust and back portion of the mannequin. This is to ensure that the final garment will drape properly.

OBJECTS OF THE INVENTION

Accordingly, it is an object of the invention to provide a method of forming a garment maker's pattern directly from a mannequin.

It is another object of the invention to provide a plastic shell which can be used to form a multiplicity of garment sizes and styles.

It is another object of the invention to provide a technique for more easily, efficiently and quickly preparing a pattern for a garment.

It is another object of the invention to provide a garment maker's mannequin which is adjustable to different styles.

BRIEF DESCRIPTION OF THE DRAWINGS

These and other objects and advantages of the invention will become more apparent from the following detailed description and appended claims taken in conjunction with the accompanying drawings in which:

FIG. 1 illustrates a perspective view of a mannequin according to the invention;

FIG. 2 illustrates a side view of the mannequin of FIG. 1 with the fit plate in retracted position;

FIG. 3 illustrates a perspective view of a shell according to the invention draped over the mannequin of FIG. 1 with the fit plate in extended position;

FIG. 4 illustrates a fragmentary cross-sectional view of the kicker plates according to the invention;

FIG. 5 illustrates a fragmentary view of the upper portion of the mannequin of FIG. 1;

FIG. 6 illustrates a cross-sectional view of the upper portion of the mannequin of FIG. 1, and

FIG. 7 illustrates an adjusting means for movement of the fit plate according to the invention.

DESCRIPTION OF THE PREFERRED EMBODIMENTS

Referring to FIG. 1, the mannequin 10 is formed of conventional contour shape and is provided with a body portion 11 and a leg portion 12 extending from the body portion 11. In addition, a fit plate 13 is mounted in one side of the upper portion of the body 11 in the region of the bustline. Also, a pair of kicker plates 14, 14' are mounted in the leg portion 12 on opposite sides of the mannequin 10. These kicker plates are disposed out of alignment with each other so as to correspond to the legs of a garment wearer. That is, kicker plate 14 is located in the front in the position of the left leg of the mannequin 10 and the other kicker plate 14' is located in the back in the position of the right leg of the mannequin 10.

Referring to FIGS. 1, 5 and 6, the fit plate 13 is of generally U-shape and is mounted in the mannequin 10 so as to be moved between a retracted position within the body portion 11 in which the exposed surface of the fit plate 13 conforms with the remainder of the body portion 11 (FIG. 1) and a fully extended position outwardly of the remainder of the body portion 11 (FIG. 6) in which the surface of the fit plate 13 is discontinuous with the remainder of the body portion 11. To this end, the fit plate 13 is pivotally mounted at the front at a point 15 corresponding to the nipple of the right bust of the mannequin 10 and at the back at a point (not shown) horizontally aligned with point 15.

The fit plate 13 is also connected intermediately thereof to an adjusting means 16 which serves to pivot the fit plate 13 about the pivot points. For example, the adjusting means 16 is formed by a ratchet bar 17 which is slidably mounted in a suitable bracket 18 secured within the body portion 11 of the mannequin 10 and a ratchet wheel 19 which is in meshing engagement with the ratchet bar 17. In addition, in order to rotate the ratchet wheel 19, a control mechanism is provided in the form of a flexible control cable 20 of suitable construction connected to the ratchet wheel 19 for rotating the wheel 19 about a fixed axis and a control knob 21 positioned at the uppermost point of the body portion 11 and connected to the cable 20. The control knob 21 is rotatable so as to cause rotation of the control cable 20 which in turn causes rotation of the ratchet wheel 19. The wheel 19 thus effects lateral movement of the ratchet bar 17. Alternatively, an electrical control mechanism can be provided in which a push button is mounted in place of the knob 21 and is used to actuate the adjusting means 16 for moving the fit plate 13 in or out, respectively. The ratchet bar 17 is further pivotally connected to the fit plate 13 at one end via an articulated extension 17' so that upon movement of the ratchet bar 17 the fit plate 13 pivots about the pivot point 15 as well as about the ratchet bar 17.

Alternatively, the fit plate 13 can be mounted so that the lower edge of the outermost portion 22 is maintained in the same horizontal plane regardless of how far in or how far out the fit plate 13 is moved. To this end a shifting or sliding pivot arrangement is used to mount the fit plate 13 within the mannequin 10. In this case the fit plate 13 is provided with curved slots 38 (shown in dotted lines in FIG. 1) in front and back about the pivot point 15 while the ratchet bar 17 is fixed directly to the fit plate to move in a horizontal plane.

The purpose of the inward and outward movement of the fit plate 13 is to provide the proper silhouette in the bustline region for the garment style to be made. For example, for a full length garment with a straight drape the fit plate 13 is swung to an outermost position so as to provide for a fullness in the bustline (FIG. 3). On the other hand, for a form-fitting garment the fit plate 13 is retracted into the innermost position (FIG. 1).

Referring to FIG. 4, each kicker plate 14, 14' is pivotally mounted at one end to the leg portion 12 of the mannequin 10 while the lower end is articulated to a pivoting mechanism 23 within the leg portion 12. For example, the lower end of each kicker plate 14, 14' is pivotally mounted on a link 24, 24' respectively at one end thereof as by a suitable pin connection 25, 25' (see FIG. 3) while the opposite end of each line 24, 24' carries a suitable guide pin 26 which is slidably mounted in a guideway 27 fixedly mounted within the leg portion 12. The guide pins 26 allow the links 24, 24' to slide up and down within the guideway 27 as the links 24, 24' cause the kicker plates 14, 14' to pivot inwardly and outwardly of the leg portion 12. The two kicker plates 14, 14' can be adjusted independently of each other or can be adjusted simultaneously by a suitable arrangement of the pivoting mechanism 23. For example, each link 24, 24' can be mounted in separate guideways (not shown) or both links can be mounted on a common pin or bar which is slidable in a single guideway between the links.

Referring to FIG. 3, the flexible shell 28, for example of plastic material, is of a pliable self-supporting nature and of generally hollow construction. The material from which the shell 28 is made is of a suitable stiffness so that the various pieces cut therefrom retain a three-dimensional shape while also of a suitable pliability so that the pieces can be flattened for cutting of the cloth. The shell 28 is sized so as to be mounted on the mannequin 10 in a shroud-like fashion. To this end, the shell 28 has an enlarged opening at the lower end so as to fit over the mannequin 10 while the upper end of the shell 28 is contoured to conform to the shoulder portion 29 of the mannequin 10, i.e., with a rounded cross-sectional shape in the shoulder region 30. In addition, the shell 28 is provided with a neck opening 31 through which the control knob 21 of the adjusting means 16 for the fit plate 13 extends as well as a pair of arm holes 32 at the end of the shoulder region 30. The shell 28, in this instance, is of a conical shape. However, any other suitable shape can be used such as a generally cylindrical shape. Also, the shell 28 is contoured in the bustline 33 to generally conform to the bustline of the mannequin 10. The shell 28 can be fixed to the mannequin 10 by the use of push pins, or the like, located at three points, namely at the shoulder, the shoulder blade and the bust in order to facilitate the subsequent cutting and manipulation thereof.

In order to form a garment maker's pattern for a particular style of garment, the fit plate 13 of the mannequin 10 is first adjusted to the condition needed to effect this style. In addition, the kicker plates 14, 14' are extended to establish the spread corresponding to the desired stride for the wearer. Next, the shell 28 is placed over the mannequin. Generally, the shell 28 would be sized so as to approximate the extended contour defined by the fit plate 13. In any event the pattern maker begins to cut the shell 28, for example with an electric knife, on one side half of the mannequin 10, i.e., the right hand half or left hand half, at various places at which a seam would be made in a garment so as to shape the shell to the style desired for the garment. It is noted that, after various cuts have been made to remove excess material, the edges of two adjacent pieces of the shell can be butted together or secured together in any suitable manner. For example, the shell can be initially provided with an outer covering of a releaseable self-adhesive sheet material throughout which, after a cut is made in the shell, can be peeled back from the cut made in the shell and, after the excess material of the shell is removed, applied over the butted pieces of the shell to hold the pieces together. The shell can also be provided with a layer of adhesive and an overlying sheet of material which is releasably bonded to the adhesive. This sheet can be manipulated in similar fashion as above. After the shell 28 has been cut and shaped into the desired contour for the one side, the shell 28 is severed into several pieces and the pieces are removed from the mannequin. The pieces which are removed are generally of three-dimensional contour and, as such, define the garment maker's pattern. Also, these pieces are symmetrical to the two halves of the mannequin 10.

In order to make a garment from the pattern pieces the various pieces which require such are slit at the edge so as to permit flattening of each. It is noted that the various slits which are made define V-shaped and other shaped grooves when the piece is flattened and

as such define places where darts or tucks are needed in the garment. The flattened pattern pieces are then disposed over a plurality of layers of fabric and a suitable machine such as an electric saw is used to trace around the shape of the pattern piece to cut the layers of fabric. It is noted that since the plastic pieces are cut to the exact size that suitable margins are made on the fabric pieces during the cutting operation so that the fabric pieces can be subsequently sewn together. Duplicate fabric pieces can then be sewn together to form the two sides of a garment.

It is noted that the shell can be provided with a plurality of horizontal lines, graduations or grooves. These horizontal lines serve as a guide to align the various pieces of the shell during cutting and trimming operations.

It is further noted that the shell and mannequin of the invention can be used for making different sizes of a particular style garment. For example, the pattern pieces can be graded on a two-dimensional basis to other sizes of garments by offsets. Also, the mannequin and shell can be of the male form as well as the female form for the purpose of styling men's clothing. The shell, in such a case, would be utilized in a similar manner as above.

Referring to FIG. 1, a separate arm piece 34 is provided for fitting into a suitable socket 35 in the mannequin 10 while a separate plastic shell (not shown) is provided in order to develop a pattern for a sleeve required to complement the style of the garment to be made. To this end, the shell for the sleeve is of substantially cylindrical cross-section and of a slightly bent length corresponding to the natural shape of an arm in a position of rest alongside a body. Also, the fit plate 13 is contoured so as to avoid interference with the arm holes 32 of the shell 28 adjacent thereto. For example, the upper edge of the fit plate is recessed in the area below the arm socket 35 of the mannequin 10 so as to provide a slight clearance when the fit plate 13 is fully extended. The shell for the sleeve is cut and shaped in similar fashion to the above described shell and need not be further described. The pieces formed from such a sleeve shell are used as a rigid pattern to obtain fabric pieces for making the sleeves of a garment.

This invention thus provides a flexible pattern that can be used for repeated uses in the manufacture of a large number of garments. Furthermore, since the pattern is a three-dimensional pattern such will provide pieces of fabric which will more accurately fit together into a garment.

The invention further provides a technique of accurately forming a master pattern in a single-phase operation directly from a mannequin. The technique does not require the preparation of a garment from the pattern to determine whether or not the garment requires any further alterations.

It is noted that the mannequin can be mounted on a suitable support frame 36 which is mounted on casters 37 so as to be moved from place to place. For example, the support frame 36 can have a circular shape.

It is further noted that where required the mannequin can be formed with adjustable fit plates on opposite sides as well as in any other area for adjustment inwardly and outwardly of the mannequin. For example, such an additional fit plate can be mounted in the lower leg region of the mannequin for bell-bottom pants and

can be actuated in a similar manner to the bustline fit plate.

The lateral excursion of the fit plate 13 from the mannequin 10 at the lowermost portion 22, assuming a conventional size ten female mannequin having a bustline of 35 inches and a waist of 24 inches, is a maximum of, for example, 5 inches. Furthermore, for a male mannequin, for example a size 42, the lateral excursion would be a maximum of 4 inches.

It is noted that the fit plate can also be made of a flexible material which is suitably guided in passing out of the mannequin so as to be bowed into a shape which increases the cross-section of the mannequin below the bustline. In such a case the portion of the fit plate extending along the back of the mannequin would be substantially straight while the portions at the front and sides of the mannequin would be progressively bowed to a greater extent as the fit plate is extended.

Further, traced patterns can also be prepared from each flattened piece of the shell so that each traced pattern is useful as a template of a garment pattern for preparing individual pieces of cloth to be pieced together into a complete garment. Also, each template can be provided with a margin to provide for seaming of subsequently cut pieces of cloth.

CONCLUSION

Protection by Letters Patent of the present invention

in all its aspects as the same are set forth in the appended claims is sought to the broadest extent that the prior art allows.

I claim as my invention:

1. In a garment maker's mannequin having a body portion and a leg portion extending from said body portion, the improvement comprising (1) at least one fit plate disposed on one side of an upper portion of said body portion and mounted adjustably thereto at a point thereon in a manner permitting movement of said fit plate inwardly and outwardly of said upper portion, and (2) a pair of kicker plates adjustably mounted in said leg portion, said kicker plates being mounted on opposite sides of said leg portion and being disposed out of alignment with each other.

2. A garment maker's mannequin as set forth in claim 1 wherein said kicker plates are pivotally mounted in said leg portion.

3. A garment maker's mannequin as set forth in claim 1 in which said improvement still further comprises means for positioning said kicker plates relative to said leg portion.

* * * * *

30

35

40

45

50

55

60

65