

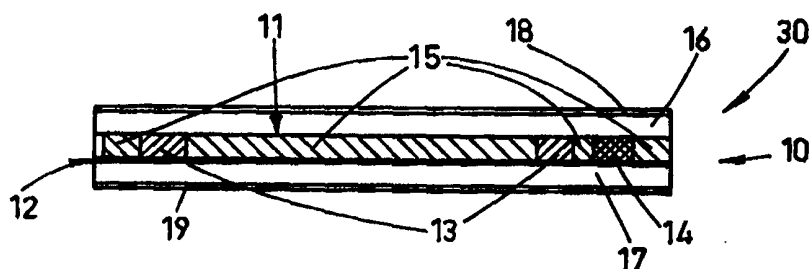

## INTERNATIONAL APPLICATION PUBLISHED UNDER THE PATENT COOPERATION TREATY (PCT)

(51) International Patent Classification <sup>6</sup> : <b>G06K 19/077</b>	<b>A1</b>	(11) International Publication Number: <b>WO 99/24934</b> (43) International Publication Date: 20 May 1999 (20.05.99)					
<p>(21) International Application Number: PCT/IL98/00549</p> <p>(22) International Filing Date: 11 November 1998 (11.11.98)</p> <p>(30) Priority Data:</p> <table border="0"> <tr> <td>122185</td> <td>12 November 1997 (12.11.97)</td> <td>IL</td> </tr> <tr> <td>126964</td> <td>9 November 1998 (09.11.98)</td> <td>IL</td> </tr> </table> <p>(71) Applicant (for all designated States except US): SUPERCOM LTD. [IL/IL]; Hataas Street 25, New Industrial Area, 44425 Kfar Saba (IL).</p> <p>(72) Inventors; and (75) Inventors/Applicants (for US only): HASSAN, Jakob [IL/IL]; Shnat Hayovel Street 21, 45304 Magdical Hod Hasharon (IL). ROZEN, Eli [IL/IL]; Heleny Hamalka Street 38, 46768 Herzlya Bet (IL). LANDMAN, Avi [IL/IL]; Hagdud Haivri Street 99, 26306 Kiriat Haim (IL).</p> <p>(74) Agents: LUZZATTO, Kfir et al.; Luzzatto &amp; Luzzatto, P.O. Box 5352, 84152 Beer-Sheva (IL).</p>	122185	12 November 1997 (12.11.97)	IL	126964	9 November 1998 (09.11.98)	IL	<p>(81) Designated States: AL, AM, AT, AU, AZ, BA, BB, BG, BR, BY, CA, CH, CN, CU, CZ, DE, DK, EE, ES, FI, GB, GD, GE, GH, GM, HR, HU, ID, IL, IS, JP, KE, KG, KP, KR, KZ, LC, LK, LR, LS, LT, LU, LV, MD, MG, MK, MN, MW, MX, NO, NZ, PL, PT, RO, RU, SD, SE, SG, SI, SK, SL, TJ, TM, TR, TT, UA, UG, US, UZ, VN, YU, ZW, ARIPO patent (GH, GM, KE, LS, MW, SD, SZ, UG, ZW), Eurasian patent (AM, AZ, BY, KG, KZ, MD, RU, TJ, TM), European patent (AT, BE, CH, CY, DE, DK, ES, FI, FR, GB, GR, IE, IT, LU, MC, NL, PT, SE), OAPI patent (BF, BJ, CF, CG, CI, CM, GA, GN, GW, ML, MR, NE, SN, TD, TG).</p> <p><b>Published</b> <i>With international search report. Before the expiration of the time limit for amending the claims and to be republished in the event of the receipt of amendments.</i></p>
122185	12 November 1997 (12.11.97)	IL					
126964	9 November 1998 (09.11.98)	IL					

(54) Title: METHOD AND APPARATUS FOR THE AUTOMATIC PRODUCTION OF PERSONALIZED CARDS AND POUCHES



## (57) Abstract

A method is provided for continuously and automatically producing contactless or regular smart cards, such as identity cards, passes and the like, bearing personalizing, and optionally non-personalizing, graphic matter, including text and, generally, identifying photographs. A base layer (11) comprising the electronic components (13, 14) is provided, is laminated to two intermediate layers (16, 17) to form a core, and the core is laminated to two cover sheets (18, 19). The card can be made directly in a continuous process, in which case the intermediate layers (16, 17) carry the previously printed, personalizing graphic matter; or a pouch can be made, in which core and cover sheets (18, 19) are connected along a side only, and be transformed into a card by transfer printing personalizing matter on the cover sheets (18, 19) and fully laminating them to the core. An apparatus for continuously and automatically carrying out the method is also provided. Smart cards having a longer life are thus obtained in a more productive and economical way.

**FOR THE PURPOSES OF INFORMATION ONLY**

Codes used to identify States party to the PCT on the front pages of pamphlets publishing international applications under the PCT.

<b>AL</b>	Albania	<b>ES</b>	Spain	<b>LS</b>	Lesotho	<b>SI</b>	Slovenia
<b>AM</b>	Armenia	<b>FI</b>	Finland	<b>LT</b>	Lithuania	<b>SK</b>	Slovakia
<b>AT</b>	Austria	<b>FR</b>	France	<b>LU</b>	Luxembourg	<b>SN</b>	Senegal
<b>AU</b>	Australia	<b>GA</b>	Gabon	<b>LV</b>	Latvia	<b>SZ</b>	Swaziland
<b>AZ</b>	Azerbaijan	<b>GB</b>	United Kingdom	<b>MC</b>	Monaco	<b>TD</b>	Chad
<b>BA</b>	Bosnia and Herzegovina	<b>GE</b>	Georgia	<b>MD</b>	Republic of Moldova	<b>TG</b>	Togo
<b>BB</b>	Barbados	<b>GH</b>	Ghana	<b>MG</b>	Madagascar	<b>TJ</b>	Tajikistan
<b>BE</b>	Belgium	<b>GN</b>	Guinea	<b>MK</b>	The former Yugoslav Republic of Macedonia	<b>TM</b>	Turkmenistan
<b>BF</b>	Burkina Faso	<b>GR</b>	Greece	<b>ML</b>	Mali	<b>TR</b>	Turkey
<b>BG</b>	Bulgaria	<b>HU</b>	Hungary	<b>MN</b>	Mongolia	<b>TT</b>	Trinidad and Tobago
<b>BJ</b>	Benin	<b>IE</b>	Ireland	<b>MR</b>	Mauritania	<b>UA</b>	Ukraine
<b>BR</b>	Brazil	<b>IL</b>	Israel	<b>MW</b>	Malawi	<b>UG</b>	Uganda
<b>BY</b>	Belarus	<b>IS</b>	Iceland	<b>MX</b>	Mexico	<b>US</b>	United States of America
<b>CA</b>	Canada	<b>IT</b>	Italy	<b>NE</b>	Niger	<b>UZ</b>	Uzbekistan
<b>CF</b>	Central African Republic	<b>JP</b>	Japan	<b>NL</b>	Netherlands	<b>VN</b>	Viet Nam
<b>CG</b>	Congo	<b>KE</b>	Kenya	<b>NO</b>	Norway	<b>YU</b>	Yugoslavia
<b>CH</b>	Switzerland	<b>KG</b>	Kyrgyzstan	<b>NZ</b>	New Zealand	<b>ZW</b>	Zimbabwe
<b>CI</b>	Côte d'Ivoire	<b>KP</b>	Democratic People's Republic of Korea	<b>PL</b>	Poland		
<b>CM</b>	Cameroon	<b>KR</b>	Republic of Korea	<b>PT</b>	Portugal		
<b>CN</b>	China	<b>KZ</b>	Kazakistan	<b>RO</b>	Romania		
<b>CU</b>	Cuba	<b>LC</b>	Saint Lucia	<b>RU</b>	Russian Federation		
<b>CZ</b>	Czech Republic	<b>LI</b>	Liechtenstein	<b>SD</b>	Sudan		
<b>DE</b>	Germany	<b>LK</b>	Sri Lanka	<b>SE</b>	Sweden		
<b>DK</b>	Denmark	<b>LR</b>	Liberia	<b>SG</b>	Singapore		
<b>EE</b>	Estonia						

**METHOD AND APPARATUS FOR THE AUTOMATIC  
PRODUCTION OF PERSONALIZED CARDS AND POUCHES**

**Field of the Invention**

This invention relates to a method for continuously and automatically producing personalized, contactless or regular, smart cards, such as identity cards, passes and the like, bearing printed graphic and textual matter, generally including identifying photographs. It further relates to the smart cards, to a new article of manufacture, known as a "pouch", and to intermediate products produced by said method.

**Background of the Invention**

Contactless smart cards presently consist of a body of PVC, generally comprising three superimposed layers, a microchip and an antenna, which constitute the electronic part of the smart card, being imbedded in the intermediate layer. Such a smart card can be made by starting from a base layer of PVC, inserting into it, by applying pressure and heat, the electronic circuit, comprising microchip and the antenna, and then connecting to said base layer two layers of PVC. The smart card is "personalized" - viz. its owner is identified by means of any relevant information - after the card is completed, usually by embossing in it "personalizing" or identifying matter, viz. the matter that identifies the owner, and other matter that refers to one owner or to a limited number of owners, such as the period of validity of the card.

Such smart cards, however, have the essential defect of a relatively short life - three, to at most, five years. A substantially longer life, e.g., more than ten

years, would be highly desirable, but could not be obtained with the types of materials presently employed for making contactless smart cards. The choice of said materials, however, is imposed by the process for making them, that is known in the art.

Further, no process is known in the art for making personalized smart cards in a continuous, automatic way, with the corresponding increase in productivity and reduction in costs; nor does the prior art disclose apparatus and machines for carrying a process into practice

It is therefore a purpose of this invention to provide a process by which personalized smart cards, contactless or regular, can be produced continuously and automatically.

It is another purpose to provide a process by which can be produced a new article of manufacture - a "pouch" - from which smart cards can be made. Preferably, said pouch should carry all or part of the information that is required in the finished card, except that which personalizes the card, viz. which carries the identification of the owner and, optionally, other information pertaining to him and other indications which may vary from card to card, e.g., the date on which it elapses.

It is a further purpose to provide a smart card which has a substantially longer life than the existing ones, ten years or more.

It is a still further purpose to provide such a smart card wherein the personalizing matter and any preprinted matter is protected against damage or interference of any kind.

It is a still further purpose to provide a contactless or regular smart card which satisfies all the requirements and meets all the standards of the market.

It is a still further purpose to provide certain intermediate products, hereinafter described, which can be separately made and used as input in the process of the invention.

It is a still further purpose to provide apparatus for carrying out the method of this invention.

It is a still further purpose to provide an integrated machine for carrying out the method of this invention

Other purposes and advantages of the invention will appear as the description proceeds.

### **Summary of the Invention**

In this application, the term "substrate" or "print substrate" means any backing on the which printing can be effected, regardless of its form and composition. The terms "picture" or "graphic matter" synonymously indicate any kind of printable or printed subject matter, and therefore comprise, among other things, pictures representing persons or objects, portraits,

photographs, letters, words, signs and any figures or images that may be carried by a substrate.

The method for the production of personalized smart cards, according to this invention, comprises the following steps:

- 1 - providing a foundation layer;
- 2 - applying to it the electronic components that are desired in the smart card;
- 3 - applying a filling to the foundation layer carrying said electronic components, whereby to create a composite base layer, which preferably has a thickness corresponding to the dimensions of the electronic components;
- 4 - providing two intermediate layers or sheets of plastic matter;
- 5 - providing two cover sheets or layers of plastic matter, one of which at least is transparent;
6. applying to at least a print substrate, chosen from among said intermediate layers and said cover layers, the desired personalizing graphic matter;
7. juxtaposing said intermediate layers to said base layer and connecting them to it by lamination over their entire surfaces, to form a core;
- 6 - juxtaposing said cover sheets to said core;
- 7 - laminating said cover sheets to said core to produce a composite sheet; and
- 8 - detaching individual segments from said composite sheet e.g. by cutting or punching.

Graphic matter can be applied to a print substrate - layer or sheet - by direct printing or by transfer, and the term "applying" is to be construed as

including both possibilities, and generally speaking, any method by which a substrate may be caused to carry graphic matter. If any layer or sheet carrying print is laminated to another layer or sheet, it is preferably juxtaposed to this latter in such a way that the face of the substrate carrying the print is adjacent to said layer or sheet, whereby, after lamination the print is enclosed between the two layers or sheets.

The steps of the method need not all be performed in the order in which they have been listed above. In particular, the method chosen for applying graphic matter to a substrate may determine the moment in which it is applied, as will become apparent as the description proceeds. Further, it is not necessary that all the steps of the process be carried out in the same apparatus and/or in the same manufacturing plant. For instance, personalizing graphic matter can be applied to plastic sheets or reels by a printer, particularly a laser printer, and then the printed sheets or reels can be used as intermediate layers and/or cover sheets and fed to an apparatus for making the smart cards or pouches. Still, the application of personalizing graphic matter is a part of the process of this invention, and it does not matter that said process is carried out partly in an apparatus and/or plant and partly in another, and that the product of certain process steps becomes the input to further process steps.

If the method is applied to make smart cards directly, the cover sheets are laminated to the core over their entire surfaces, and the said individual segments are the finished smart cards.

If the method is applied to make the pouches, hereinafter described, from which the smart cards can be made, the cover sheets are laminated to the core only along one edge thereof, and the said individual segments are the pouches.

The words "layers", "sheets" or "leaves" are used herein as synonyms, and though the terms "intermediate layers" and "cover sheets" or "leaves" will mostly be used, for the sake of a clearer description, this does not imply a difference between the meanings to be attributed herein to those words.

Personalizing matter, and graphic matter in general, can be printed on, or transferred to, at least one of the intermediate layers or on at least one of the cover sheets, or on both. By "personalizing matter" is obviously understood graphic matter that identifies a smart card owner or a specific group of smart card owners. The corresponding printings or transfers are also steps of the process of the invention.

Preferably said foundation layer, said composite base layer sheet, said intermediate layers, said core, said cover sheets and said composite sheet are continuous or continuously fed, or, in other words, the entire process is a continuous succession of operations, and the components that are fed into it (feed components) and the intermediate structures generated by it are continuous structures. The feed components, when continuous, are preferably, though not necessarily, provided in the form of reels, mounted on rotatable supports, from which they can be unwound. They may be printed, before being wound onto the supports and the print will be carried by the inside surface of the reels. The feed components, however, can be provided



and fed as individual sheets, having a size corresponding to a number, even a small number, of cards. Means for feeding sheets are known to persons skilled in the art and need not be described.

In a variation of said process, the base layer may be provided as such in a previous manufacturing stage, said provision taking the place of steps 1 to 3 hereinbefore listed, and form a reel that becomes a feed component or input to the process. However, as has been said, the overall process will remain the same as herein defined, although it is separated into two, or even more than two, stages, which may even be carried in different manufacturing plants. Therefore the base layer may be produced and marketed as an article of manufacture and is, in itself, a part of this invention; and the same is true of the core. When graphic matter is printed on the intermediate layers, once these have been laminated to the base layer the core carries the graphic matter.

The plastic material, of which the intermediate layers are made, is preferably, but not necessarily, a thermo-mechanically sensitive material or print substrate, such as Teslin. Teslin® is a product of PPG industries, Inc., Pittsburgh Pa. Teslin® is described as a single layer, highly filled, microporous plastic film, based on polyolefin material and containing about 60% by weight of silica, available in gauges ranging from 7 Mil up to 18 Mil. Its properties have been described by the manufacturer and are known to persons skilled in the art. Other suitable materials are the polyesters and polyethylene.

The thermo-mechanically sensitive materials herein particularly referred to are synthetic printing substrates, which, when printed upon and set in conventional laser printers, become severely or significantly damaged, often to such an extent that they cannot be used at all. If an attempt is made to render the setting conditions of laser printers less severe, in order not to damage the plastic card backing, then the setting is insufficient, the print is not stable, and once again the card is not satisfactorily usable.

The foundation layer is made of plastic matter preferably chosen from among polyester, Teslin and polyethylene, polyester, e.g., Mylar™ produced by DuPont, being preferred. The filling applied to the foundation layer is preferably of the same material as said layer.

The plastic material of which the intermediate sheets are made is preferably Teslin, but optionally may be the same as that of the foundation layer, or at least be chosen from the group of materials suitable for this latter.

Preferably, the foundation layer has a thickness of 0.1 to 0.7  $\mu\text{m}$ , the base layer has a thickness comprised between 150 and 900  $\mu\text{m}$ , and the intermediate layers have a thickness of 150 to 500  $\mu\text{m}$ ; the cover leaves have a thickness of 50 to 250  $\mu\text{m}$  and the overall thickness of the core and said leaves, when laminated together, is about from 0.760 to 1.5 mm.

The article of manufacture - the pouch - according to an aspect of the invention, comprises five layers:

a center layer, which comprises the electronic circuits (the essential components of which are a microchip, an antenna and the necessary electrical connection, as known in the art) - the "base layer";

two intermediate layers juxtaposed to the base layer, each to one face thereof, and laminated thereto over their entire surface areas, to constitute a three-layer assembly - the "core"; and

two cover leaves, one of which at least is transparent, juxtaposed each to a face of one of the core;

said cover leaves and said core being laminated together along a narrow band at one side, but unattached along the other sides.

The dimensions of the component layers of the smart card, set forth hereinbefore, apply to the pouch as well, as it is evident that the layers that make up the pouch, make up the card as well, and *vice versa*. The changes in thickness that may occur in the laminating steps, are not taken into account in defining said dimensions.

The pouch, as well as the card that can be made from it, is usually rectangular, and in that case the word "side", as used hereinbefore, means a side - one of the longer or one of the shorter sides - of the rectangular shape. However, this must not be construed as a limitation, since the pouch and the card could have a geometric shape different from that of a rectangle, and in that case the word "side" is to be construed as meaning a straight or curved segment of the pouch periphery. The only limitation is, that such a segment should not be so extensive as to prevent the degree of access to the rear faces (as hereinafter defined) of the cover leaves, or of the faces of the core, that is

necessary to carry out the transformation of the pouch to a card in the way described hereinafter.

The invention further provides a finished contactless or regular smart card, which comprises all of the components of the pouch, in the same positioned relationship as in the pouch, but wherein the cover leaves are attached to the core over their entire surface areas. Preferably, in the finished card all the components have the same shape and dimensions.

The finished card is "personalized" and provided with all other required information, if any. The face of the card from which the personalizing information is visible, will be called the "top face" and the other the "bottom face". Correspondingly, the core will be said to have a top and a bottom face, respectively underlying the top or bottom face of the card. Additionally, non-personalizing information may be preprinted on any face of the core, and in general on component layer or sheet of the card, by conventional means, and will not be considered in defining and describing this invention. The invention also includes and relates to cards wherein the personalizing matter is visible by looking at either face of the card, or part of it is visible by looking at one face and part by looking at the other face. In this case, it is obviously indifferent which face is considered the top or the bottom one. One of the intermediate layers forms the top face of the core, and will be hereinafter called the "top intermediate layer". The opposite intermediate layer that forms the bottom face of the core will be called the "bottom intermediate layer".

The cover sheet or leaf that forms the top face of the card (hereinafter, "the top cover leaf") is transparent. The cover leaf that forms the bottom face of the card (hereinafter, "the bottom cover leaf") is preferably, but not necessarily, transparent. Both cover leaves are preferably made of a material chosen from among Teslin and polyester, the polyester being, e.g., Mylar™, and are laminated to the core.

As has been said, the base layer has a thickness which is dictated by the dimensions of the electronic components and is generally substantially equal to the thickness of said components. Typically, said thickness is comprised between 150 and 900  $\mu\text{m}$ . The intermediate layers and the cover leaves have a thickness that is determined by the final, overall thickness of the smart card. A typical thickness of this latter is 0.760 to 1.5 mm and, typically, the intermediate layers may have a thickness of 400 to 500  $\mu\text{m}$ , and the cover leaves may have a thickness of 30 to 250  $\mu\text{m}$ . The electronic circuits of the smart card are the conventional ones used in contactless smart cards, and include conventional components and connections, so that no description thereof is required.

The pouch constitutes *per se* an article of manufacture, which can be sold by its manufacturer to the distributors of contactless smart cards or to suppliers of those distributors, who will personalize it and transform it into the final card. This is done by: a) applying printed personalizing matter (and other auxiliary information, if any) to the rear face of the top cover leaf, or of both cover leaves (by "rear face" is meant the face adjacent and connected to the core), or to one or both faces of the core; b) laminating the core and the cover leaves together by the application of pressure and heat, and,

optionally, adhesive. By "laminating" is understood herein the operation of joining two or more thin, juxtaposed, layers together over all or part of their surfaces, regardless of the process and apparatus means used for doing it.

In a preferred variant of the invention, the base layer comprises a very thin film - the foundation layer - of polyester, e.g., having a thickness of 0.1 to 0.7 $\mu$ m, onto which the electronic components are placed and adhesively connected, and a filling which fills all the spaces between the electronic components, over the entire surface of the base layer, to a height corresponding to the thickness of the said components, whereby to complete the base layer, which becomes a flat, composite sheet having the thickness of the electronic components. Said filling may be of the same material as the foundation, or of a different material.

A preferred process for producing the pouch, according to the invention, comprises the following steps:

- 1 - providing the aforesaid foundation layer;
- 2 - applying to it the electronic components (comprising the microchip, the antenna and the necessary connections), preferably by connecting them to it by an adhesive of any suitable kind, previously applied to said foundation;
- 3 - applying to the foundation, carrying the electronic components, the required filling, whereby to create the base layer, viz. a sheet having a thickness dictated by the dimensions of the electronic components;
- 4 - juxtaposing the two intermediate layers (optionally carrying preprinted matter) to the base layer and connecting them to it by lamination over their entire surfaces, to form the core; and

5 - juxtaposing the two cover leaves of transparent plastic matter to the core and connecting them to it, adhesively or by the application of pressure and heat, along a narrow band at one edge, to create the pouch.

A method for the production of personalized smart cards, according to a preferred embodiment of this invention, comprises the following steps:

- 1 - providing a foundation layer;
- 2 - applying to it the electronic components that are desired in the smart card;
- 3 - applying a filling to the foundation layer carrying said electronic components, whereby to create a composite base layer having a thickness corresponding to the dimensions of the electronic components;
- 4 - providing two intermediate layers carrying the personalizing graphic matter and, optionally, non-personalizing matter;
- 5 - juxtaposing said intermediate layers to said base layer and connecting them to it by lamination over their entire surfaces, to form a core;
- 6 - providing two cover sheets of transparent plastic matter;
- 7 - juxtaposing said cover sheets to said core;
- 8 - laminating said cover sheets to said core over their entire surfaces, whereby to produce a composite sheet; and
- 8 - detaching individual personalized smart cards from said composite sheet, e.g. by cutting or punching.

When a sheet that is laminated carries printed graphic matter, the statement that it is laminated over its entire surface, whenever used herein, should be construed to include lamination over the part of the surface that does not carry such matter.

According to an alternative embodiment of the invention, a process for producing the finished, contactless smart card, comprises the following steps:

A - making a pouch, by the steps hereinbefore described;

B - applying the personalizing matter, and optionally other information, onto the rear face of the top cover leaf, or on the rear faces of both cover leaves, or on one or both faces of the core, as hereinafter described; and

C - laminating the cover leaves, over their entire surfaces, to the core.

A process by which printed matter is applied to the rear face of the front leaf of a card blank comprising a front and a back leaf is described in application PCT/US 96/05084, the contents of which are included herein by reference. By essentially the same process, personalizing matter, and optionally other matter, can be printed on rear faces of one or of both of the cover leaves, or on one or both faces of the core.

Conventional laser printing comprises a setting stage for rendering the print or graphic matter, viz. the coloring matters or toners which define it, stage in which heat and pressure are applied to the print substrates onto which the toners have been applied. Substrates made of thermo-mechanically sensitive materials might be damaged in such a stage. A simple test, described in copending PCT Patent Application No. PCT/US95/13860, permits to determine whether a given substrate is thermo-mechanically sensitive, in the sense in which this expression is used in the present application. It suffices to pass the substrate between two rollers, heated to minimum 120 °C and pressed against one another with a pressure of



minimum 150 Kg. If this operation significantly affects the substrate, as to its physical properties or appearance or other properties relevant to its function as a print substrate, it should be classified as "thermo-mechanically sensitive".

To avoid damage to said materials, a laser printing process has been developed and forms the subject matter of said copending PCT Patent Application, which process comprises only partially setting the toners by radiant heating and thereafter bonding the substrate on one or both faces by lamination to a coating film or films, whereby the toners are completely set and protected. In carrying out this invention, the personalizing matter is preferably printed by laser printing. When it is printed on continuous sheets, particularly cover sheets of a thermo-mechanically sensitive material, e.g. Teslin, the laser printed matter is also partially set, preferably by radiant heating, and the partially set matter is sufficiently stable to permit winding and rewinding the continuous sheets, and generally handling them, as required by the process of this invention. Color laser printers which print on individual sheets or on continuous reels are available on the market, e.g. the Xikon printer, and only need to be modified to carry out the partial setting. Alternatively, it would be possible to laser print the personalizing matter on separate pieces of print substrate and apply them to a continuous sheet by means of an adhesive and/or of cold lamination, or to reverse print separate pieces and laminate them to a continuous sheet.

The invention further comprises an apparatus for making personalized, contactless or regular, smart cards, which comprises;

a - means for storing and delivering: I - a foundation layer carrying the electronic components that are desired in the smart card; II- a filling; III - two intermediate layers of plastic matter; and IV - two cover sheets of plastic matter;

b - guide means for : I - guiding said filling into contact with said foundation layer carrying said electronic components, whereby to create a composite base layer; II - guiding said two intermediate layers into contact with said base layer; and III - guiding two cover sheets of transparent plastic matter into contact with said core;

c - laminators for laminating: I - said filling to said foundation layer; whereby to form a composite base layer - II- said two intermediate layers to said base layer, whereby to form a core; and III - said two cover sheets to said core, whereby to produce a composite sheet;

d - means for applying traction at least to said composite sheet, to cause said foundation layer, intermediate layers and cover sheets to advance continuously; and

e - means for separating segments from said composite sheet.

Said segments are the finished smart cards. However, an apparatus as defined above can be used for making pouches, and if so, said segments are the pouches.

### **Brief Description of the Drawings**

In the drawings:

- Fig. 1 is a schematic perspective view from above of a personalized contactless smart card according to an embodiment of the invention;

- Fig. 2 is a cross-section of the smart card of Fig. 1, taken on plane II-II of Fig. 1, parallel to the longer side of the card;
- Fig. 3 is a schematic perspective view from the bottom of the smart card of Fig. 1;
- Figs. 4 is a schematic illustration of the process for making personalized, contactless smart cards, or pouches, according to an embodiment of the invention;
  - Figs. 5 to 7 and 7A illustrate the steps of said process;
  - Figs. 8 to 10 illustrate in schematic cross-section the products (base layer, core and smart card) generated in various stages of the process according to an embodiment of the invention;
  - Fig. 11 is a schematic cross-section of a pouch according to an embodiment of the invention (from which the smart card of Figs. 1 to 3 can be produced) taken on a plane parallel to the longer side of the card; and
  - Figs. 12 to 15 illustrate a process for printing the personalizing matter, according to an embodiment of the invention.

### **Detailed Description of Preferred Embodiments**

Figs. 1 to 3 illustrate a finished contactless smart card according to an embodiment of the invention. 11 generally indicates the base layer, which comprises, in this embodiment, a foundation 12 of polyester, e.g., Mylar™, an antenna 13, a microchip 14, and a filling 15, preferably but not necessarily of the same material as the foundation layer. 16 is the top intermediate layer. 17 is the bottom intermediate layer. The intermediate layers are preferably made of Teslin. Layers 11, 16 and 17, together, form the core, generally indicated at 10. 18 and 19 are the top and bottom cover

leaves. The thickness of their various layers is exaggerated in these and other figures for purposes of illustration.

In Fig. 1, 20 designates the preprinted matter on the top face of the core (shown only schematically) and 21 is the personalizing printed matter (also shown only schematically). All of such printed matter is visible through top cover leaf 18, which is transparent. Fig. 3 shows non-personalizing, preprinted matter 20' as well as personalizing matter 21', carried by the bottom face of the core, and visible through the unprinted, transparent, bottom cover leaf. If no printed is to be visible through the rear face of the bottom cover leaf, this latter may be opaque.

Fig. 11 schematically illustrates a pouch, according to an embodiment of the invention, in cross-section on a plane corresponding to the plane II-II of the cross-section (Fig. 2) of the finished card. The components of the pouch, generally designated by 30, are indicated by the same numerals which have been used to designate them in the finished card. The cover leaves 18 and 19 are shown as separate from core 10, which is a laminate constituted by the base layer 11 and the intermediate layers 16 and 17. The core 10 and the intermediate layers are connected together only along edge 31-32. In this embodiment, the pouch is rectangular and edge 31-32 is one of its shorter edges, but could be one of its longer edges.

A preferred, though not exclusive, process for making the smart card according to the invention, is generally illustrated in Fig. 4, intermediate results of it being shown in Figs. 5 to 7 and 7A, but it should be understood

that any smart card as structurally defined herein is included in the scope of the invention, even if produced by a different process.

In Fig. 4, numeral 35' indicates a reel e. g. of polyester material, from which strip 35 that forms the foundation 12 is unwound. Alternative ways of producing and feeding the foundation layer as well as the other layers involved in the process, will be mentioned hereinafter. The upper face of strip 35 carries thereon an adhesive. A strip 36, fed from a reel 36', is a thin layer which carries the electronic circuits, each including an antenna 13 and a microchip 14 and the connections therebetween, at distances from one another corresponding to the dimensions of the desired core. Said electronic circuits are transferred to foundation layer 12 and become attached to it through said adhesive. The strip 36, from which the circuits have been removed, is collected by a trash collector 42.

Successively, the filling 15 is applied to it. One convenient way of applying said filling is to feed, from another reel 37', schematically indicated in the figure but actually located in any convenient position, another strip 37 of a desired material, preferably the same material of which the foundation layer is made.

Strips 35, 36 and 37 are advanced in the appropriate, registered positioned relationship. Numeral 38 schematically designates guide rollers applied to guide the strips throughout their processing.

The registered strips 35, 36 and 37 pass through a laminator 39 which applies pressure and heat. If the strips move continuously, the laminator is

of the roller type. If they move by increments, the laminator may be of the pressure plate type. The lamination causes the material of strip 37 to fill the spaces between the electronic components which have been applied to the foundation and to join firmly together the filling, the electronic circuits and the foundation, to produce what may be called a base layer or strip 40.

Fig. 5 shows, in schematic perspective, a segment of the base layer strip 40, which comprises the foundation layer 12 (the thickness of which is exaggerated in the drawing), the electronic circuits 13-14, attached to it, and the filling 15. Generally, the edges of the foundation strip 12 are left blank, as indicated at 41. For illustration purposes, the filling is shown as separated by narrow transverse strips 41' into elements having the length of the finished cards, though such a separation generally does not exist at this stage. Fig. 8 is a schematic cross-section of such an element.

In an alternative embodiment of the invention, the base layer strip may be formed separately, and preferably wound in a reel, and becomes an input to the remaining stages of the process.

Base layer 40 is then laminated to the two intermediate layers, at least one of which has previously been printed, as described hereinbefore, with personalizing, and - if desired - non-personalizing - graphic matter. Said intermediate layers, in the form of strips 43 and 44, are unwound from reels 43' and 44' respectively. Then they are laminated to base layer 40 by laminator 45, similar to laminator 39 (though it may laminate the intermediate layers only on that part of their surface that does not carry graphic matter), to produce what may be called core strip 46 (Fig. 6),

constituted by a succession of cores 10, joined by blank edges 47, which are constituted by blank edges 41 and by superimposed edges of strips 43 and 44, having the same dimensions respectively as edges 41. In this figure too, separations between individual cores by transverse strips 47' are shown for purposes of illustration, though they generally do not exist at this stage. Fig. 6 is a schematic cross-section of an individual core.

A top cover sheet or leaf strip 48 and a bottom cover sheet or leaf strip 49 are unwound from reels 48' and 49' respectively. They are laminated to core strip 46 on their entire surfaces by laminator 50, which may be similar to laminator 39. Top cover leaf strip 48 at least is transparent. The resulting card strip 51 (see Fig. 7) is constituted by a succession of cards 55 and blank edges 53. In this figure too, separations between individual cards by transverse strips 53' are shown for purposes of illustration, though generally they do not exist at this stage. Fig. 7 is a schematic cross-section of an individual card.

All laminations are carried out by the application of pressure and heat and, optionally, by the use of adhesive in conjunction with pressure or pressure and heat.

In an alternative embodiment of the invention, wherein pouches are the produced article, to be subsequently personalized to finished smart cards, a top cover leaf strip 48 and a bottom cover leaf strip 49 are laminated to core strip 46 along only one edge 31-32 thereof (see Fig. 11), by laminator 50, which in this case is an edge laminator and has the appropriate configuration for carrying out this function, viz. has a sufficiently narrow

operative surface, whether it is of the roller or of the plate type. Top cover leaf strip 48 at least is transparent. The resulting strip 51a, shown in Fig. 7A, is similar to a card strip 51, may be called "pouch strip", and is constituted by a succession of pouches 55a, joined by blank edges 53a having the same dimensions respectively as edges 41, and having transverse edges 53'a. The core and the cover leaves are joined only at one edge - the forward edge as seen in Fig. 7A - as is emphasized in said figure by showing top cover sheet 48 as curled up at the unjoined edge. In all other respects, this embodiment does not differ from the embodiment for directly making smart cards, previously described.

All laminations are carried out by the application of pressure and heat and, optionally, by the use of adhesive in conjunction with pressure or pressure and heat.

In Fig. 4, the several strips are assumed to be fed from corresponding reels and to be considered continuous. However, the strips could be provided in different forms and fed in different ways. E.g., segmental sheets, each having a length corresponding only to a relatively small number of pouches, could be fed by means easily provided by skilled persons and subjected to the operations described with reference to Fig. 4. Such segmental strips could be provided, printed when needed and fed to the process and processed in straight configuration. It would be possible, although in general not desirable, to provide, feed and process unit elements, viz. layer elements each having dimensions corresponding to one card. Further, it would be possible to form the strips, e.g. by extrusion or calendering, and feed them directly to the process steps described with reference to Fig. 4. All such



possible variants, and others that could be conceived by skilled persons, are within the scope of the invention. The schematic illustration of reels in Fig. 4 should be construed, therefore, as schematically representing any devices for feeding either continuous or segmental layers or sheets.

Individual cards 55, or pouches 55a, are then cut or punched out of card strip 51 or pouch strip 51a respectively, by means of cutter 56, of any suitable type and size, and are collected in collector 57. The part of strip 51 or 51a that remains after the cutting, and includes the blank edges 53 or 53a, and, possibly, narrow transversal strips separating successive cards or pouches, is collected by a trash collector 58. The traction required to advance the various strips along the process line described is provided by said collector 58 and, if required, by traction rollers, which may be a number of the guide rollers 38 or may be additional rollers, not shown.

It is clear that the process can be, and desirably will be, rendered automatic by providing a control, e.g. an electronic control, that activates the motors, which produce the various motions that are part of the process, in the appropriate synchronism. Such a control, being a matter of design, within the ability of persons skilled in the art, need not be described.

In an embodiment of the invention, personalizing matter or information can be applied to the rear face of the top cover leaf of the pouch essentially by a process described in application PCT/US96/05084, hereinbefore mentioned. Said application describes, among other things, a method for making cards wherein the card may comprise an inner, opaque layer, and two cover leaves, one of which at least is transparent. Said method starts from the provision

of a card blank - in this application, the method starts from the pouch described hereinbefore - one or more of the components of which may, and generally will, carry preprinted matter. After the provision of said pouch, and after a printer, which is preferably a laser printer, is programmed with a set of digital signals defining the desired identifying matter - herein called "personalizing matter" or "personalizing information"- the following operations are carried out:

- a) providing a temporary substrate;
- b) depositing on said temporary substrate colors (toners) whereby to print the desired identifying (personalizing) matter, preferably as in the conventional laser printing method;
- c) provisionally setting said printed identifying (personalizing) matter, preferably by the application of radiant heat without application of pressure;
- d) juxtaposing said temporary substrate with the surface that has been chosen to carry the identifying (personalizing) matter, which may be the rear face of a cover leaf or a face of the core of the pouch;
- e) transferring said identifying (personalizing) matter from the said temporary substrate to said chosen surface, whereby said identifying (personalizing) matter is transferred to it and is visible through at least one transparent cover;
- f) removing said temporary substrate; and
- g) subjecting the pouch to lamination whereby to produce the finished smart card, the identifying (personalizing) printed matter being visible through at least a transparent cover leaf, viz. the top cover leaf thereof or both cover leaves.

Desirably, the temporary substrate has a surface that is less adhesive to the coloring matters used than the surface chosen to carry the personalizing matter.

If the personalizing matter is to be applied in whole or in part to the rear face of both cover leaves, the above operations will have to be carried out twice, once for each leaf. If the personalizing matter is to be applied in whole or in part to a face or both faces of the core, it may be printed on the intermediate layers directly, in the same way as it can be printed on the cover sheets

An embodiment of said process, wherein the surface chosen to carry the personalizing matter is the rear surface of the top cover leaf, is illustrated by Figs. 12 to 15. In Fig. 12, a pouch 55a is illustrated as comprising a core 61, which comprises the base layer and the two intermediate layers hereinbefore described. Pouch 55a further comprises top cover leaf 62 and bottom cover leaf 63. In pouch 55s, the core 61 and the cover leaves are connected along one edge, as shown at 64. Fig. 12 also shows a temporary substrate 65, carrying the printed and provisionally set identifying matter generally indicated at 66.

Fig. 13 shows pouch 55a after the temporary substrate 66 has been inserted into the pouch, adjacent to its top leaf.

In Fig. 14, the pouch is shown as it is after the printed matter of the temporary substrate has been transferred to the rear face of the top cover leaf 62 and the temporary substrate has been removed. Fig. 15 shows the

card resulting from the final lamination of the cover sheets to the core, although in this figure, as well as in Figs. 12 to 14, some components of the pouch are shown as bent and separate for purposes of illustration.

Further details as to said process are provided by said PCT application.

If personalizing information is to be carried by the bottom cover leaf as well, it can be directly printed on it by laser printing or applied to it in the same manner as described above with respect to the front cover leaf.

If the core has been formed by lamination of unprinted intermediate sheets to the base layer, and personalizing information is to be carried by the top or bottom face thereof, steps a) to c) of the process described for applying such information to the front cover leaf are repeated, but in step d) the temporary substrate is juxtaposed to the face of the core that has to carry the information, with its face carrying the personalizing matter in contact with said core face; and in step e) personalizing matter is transferred from the temporary substrate to by the top or bottom face of the core and is visible through said the adjacent cover leaf from the top face thereof; whereafter the temporary substrate is removed.

As said hereinbefore, the scope of this application is not limited to said preferred processes, but any smart card or pouch as structurally defined herein is comprised within said scope. In particular, if the personalizing matter is printed on an intermediate layer, before or after laminating it into the core, it will be already present in the pouch and it will be sufficient to subject the pouch to lamination on all its surface to produce the card,

wherein the printed matter will be visible through the near cover leaf. In any case, whether the card according to the invention is made by the described preferred processes or by any alternative process, any printed matter carried by it, including the identifying information, is protected by the cover leaves and is tamper-proof. Any preprinting on any component of the pouch and card, particularly on the intermediate sheets, will not affect the process herein described and the structure of the card and pouch according to the invention.

While preferred embodiments of the invention have been described by way of illustration, it will be understood that the invention may be carried out with many variations, modifications and adaptations, without departing from its spirit or exceeding the scope of the claims.

### CLAIMS

1. Method for the production of personalized, contactless or regular, smart cards or smart card pouches, which comprises the steps of:

1 - providing a foundation layer;

2 - applying to it the electronic components that are desired in the smart card;

3 - applying a filling to the foundation layer carrying said electronic components, whereby to create a base layer having a thickness corresponding to the dimensions of the electronic components;

4 - providing two intermediate layers of plastic matter;

5 - providing two cover sheets of plastic matter, one of which at least is transparent;

6. applying to at least a substrate, chosen from among said intermediate layers and said cover sheets, the desired personalizing graphic matter;

7. juxtaposing said intermediate layers to said base layer and connecting them to it by lamination over their entire surfaces, to form a core;

6 - juxtaposing said cover sheets to said core;

7 - laminating said cover sheets to said core to produce a composite sheet;  
and

8 - detaching individual segments from said composite sheet.

2. Method according to claim 1, carried out automatically.

3. Method according to claim 1, wherein the cover sheets are laminated to said core over their entire surfaces, and the individual segments detached from the composite sheet are smart cards.

4. Method according to claim 1, wherein the cover sheets are laminated to said core only along one edge thereof, and the individual segments detached from the composite sheet are pouches.

5. Method according the claim 1, wherein the foundation layer, the composite base layer, the intermediate layers, the core, the cover sheets and the composite sheet are in the form of continuous reels.

6. Method according the claim 2, wherein the intermediate layers are in the form of separate, individual sheets.

7. Method according the claim 1, wherein the base layer is provided as such in a previous manufacturing process.

8. Method according the claim 1, wherein graphic matter is applied to the core through the intermediate layers.

9. Method according the claim 1, wherein the plastic material of which the intermediate layers are made is a thermo-mechanically sensitive material.

10. Method according the claim 1, wherein the plastic material of which the cover sheets are made is chosen from among Teslin, polyethylene and polyesters.

11. Method according the claim 1, wherein the plastic material of which the intermediate layers are made is chosen from the group of materials suitable for the cover sheets.

12. Method according the claim 1, wherein the foundation layer is made of plastic matter chosen from among polyester, Teslin and polyethylene.

13. Method according the claim 1, wherein the filling applied to the foundation layer is of the same material as said layer.

14. Method according the claim 1, wherein the personalizing matter is printed by laser printing.

15. Method according the claim 11, wherein the personalizing matter is printed by a laser printing process, which comprises only partially setting the toners by radiant heating at least as to the cover sheets and to any layers made of a thermo-mechanically sensitive material.

16. Method according the claim 11, wherein the printing is carried out on continuous sheets by a laser printer.

17. Method according the claim 1, wherein the foundation layer is of polyester and the intermediate layers are of Teslin.

18. A pouch, for making a smart card, which comprises:



a base layer, which comprises the electronic circuits required for the finished smart card;

two intermediate layers juxtaposed to the base layer, each of one face thereof, and laminated thereto over their entire surface, to constitute a three-layer core; and

two cover leaves, one of which at least is transparent, juxtaposed each to a face of one of said core;

said cover leaves and said core being attached together along one side, but unattached along the other sides.

19. A pouch according to claim 18, wherein the foundation layer is made of polyester and the intermediate layers are made of Teslin.

20. A pouch according to claim 18, wherein the cover leaves are made of polyethylene.

21. A pouch according to claim 18, wherein the core is preprinted at least on one face thereof.

22. A pouch according to claim 18, wherein the base layer comprises a foundation onto which the electronic components are placed and adhesively connected, and a filling which fills all the spaces between said electronic components to complete a base layer having the thickness dictated by the dimensions of said electronic components.

23. A pouch according to claim 18, wherein the foundation layer has a thickness of 0.1 to 0.7  $\mu\text{m}$ , the base layer has a thickness comprised between

150 and 900  $\mu\text{m}$ , the intermediate layers have a thickness of 150 to 500  $\mu\text{m}$ , and the cover leaves have a thickness of 30 to 250  $\mu\text{m}$ , the overall thickness of said core and said leaves, when laminated together, being from 0.760 to 1.5 mm.

24. A pouch according to claim 22, wherein the filling is made of the same material as the foundation.

25. A smart card, which comprises:

a core, comprising a base layer including a foundation layer, the electronic components and a filling, and a top and a bottom intermediate layer on the two faces thereof, said intermediate layers being laminated to said base layer; and

a top and a bottom cover leaves, the top leaf at least being transparent, said leaves being laminated respectively to said top and a bottom intermediate layer;

personalizing matter visible through at least one of said cover leaves, said matter being carried by a surface chosen from among: a) a face of at least one of said intermediate layers, or b) the rear face of at least one of said cover leaves core.

26. A smart card according to claim 25, wherein the foundation layer has a thickness of 0.1 to 0.7  $\mu\text{m}$ , the base layer has a thickness comprised between 150 and 900  $\mu\text{m}$ , the intermediate layers have a thickness of 150 to 500  $\mu\text{m}$ , and the cover leaves have a thickness of 30 to 250  $\mu\text{m}$ , the overall thickness of said core and said leaves, when laminated together being from 0.760 to 1.5 mm.

27. Process according to claim 1, wherein the electronic components, are connected to the foundation layer by means of an adhesive previously applied to said foundation.

28. Process for making a contactless smart card, which comprises making a pouch as defined in claim 18, applying personalizing matter to a surface chosen from among the rear face of at least one of said cover leaves, or at least one of the faces of said core, and laminating the core and cover leaves together.

29. Process according to claim 28, wherein the personalizing matter is applied to the chosen surface or surfaces by carrying out the following steps:

- a) providing a temporary substrate;
- b) depositing on said temporary substrate colors whereby to print the desired personalizing matter;
- c) provisionally setting said printed personalizing matter by the application of radiant heat without application of pressure;
- d) juxtaposing said temporary substrate with its face carrying said personalizing matter in contact with said chosen surface;
- e) transferring said personalizing matter from the said temporary substrate to said cover leaf, whereby said personalizing matter is applied to said chosen surface; and
- f) removing said temporary substrate.

30. Process according to claim 1 for the production of personalized smart cards, which comprises the steps of:

- a - providing a foundation layer;
- b - applying to it the electronic components that are desired in the smart card;
- c - applying a filling to the foundation layer carrying said electronic components, whereby to create a composite base layer having a thickness corresponding to the dimensions of the electronic components;
- d - providing two intermediate layers carrying the personalizing graphic matter and, optionally, non-personalizing matter;
- e - juxtaposing said intermediate layers to said base layer and connecting them to it by lamination over their entire surfaces, to form a core;
- f - providing two cover sheets, one of which at least is transparent;
- g - juxtaposing said cover sheets to said core;
- h - laminating said cover sheets to said core over their entire surfaces, whereby to produce a composite sheet; and
- i - detaching individual personalized smart cards from said composite sheet, e.g. by cutting or punching.

31. Apparatus for making personalized, contactless or regular, smart cards, or pouches, which comprises;

- a - means for storing and delivering: I - a foundation layer carrying the electronic components that are desired in the smart card; II- a filling; III - two intermediate layers of plastic matter; and IV - two cover sheets of plastic matter;
- b - guide means for : I - guiding said filling into contact with said foundation layer carrying said electronic components, whereby to create a composite base layer; II - guiding said two intermediate layers into contact with said

base layer; and III - guiding two cover sheets of transparent plastic matter into contact with said core;

c - laminators for laminating: I - said filling to said foundation layer; whereby to form a composite base layer - II- said two intermediate layers to said base layer, whereby to form a core; and III - said two cover sheets to said core, whereby to produce a composite sheet;

d - means for applying traction at least to said composite sheet, to cause said foundation layer, intermediate layers and cover sheets to advance continuously; and

e - means for separating segments from said composite sheet.

32 - Apparatus according to claim 31, wherein the foundation layer, the filling, the two intermediate layers, and the two cover sheets are in form of reels, and the means for storing and delivering them are rotatable supports of said reels.

33. Apparatus according to claim 31, wherein the guide means are guide rollers.

34. Apparatus according to claim 31, wherein the means for separating segments from said composite sheet are chosen from among cutters and punchers.

35. Apparatus according to claim 31, further comprising automatic controls for synchronizing all moving parts.

36. Apparatus according to claim 31, comprising means for feeding and guiding segmental sheets.

37. Machine for making personalized, contactless or regular, smart cards, or pouches, which comprises the components of the apparatus of claim 31, a common base structure and a synchronizing control for all moving parts.



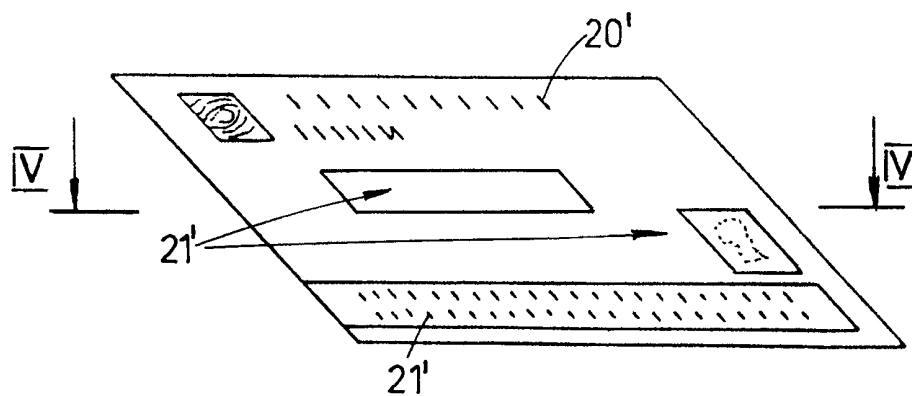

Fig. 3

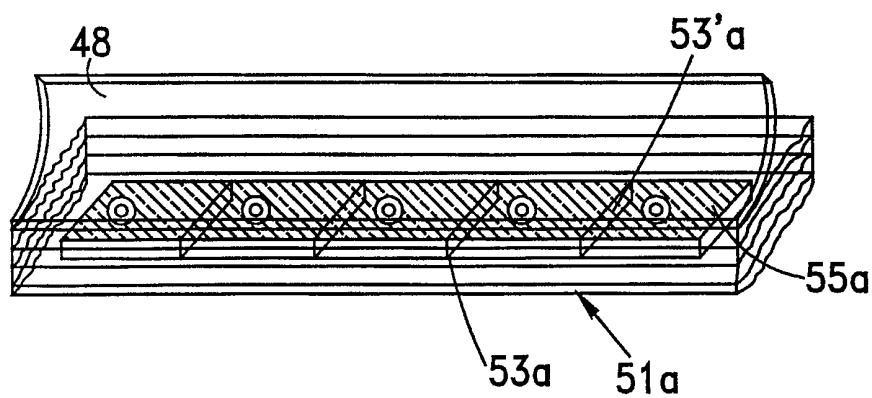

Fig. 7A



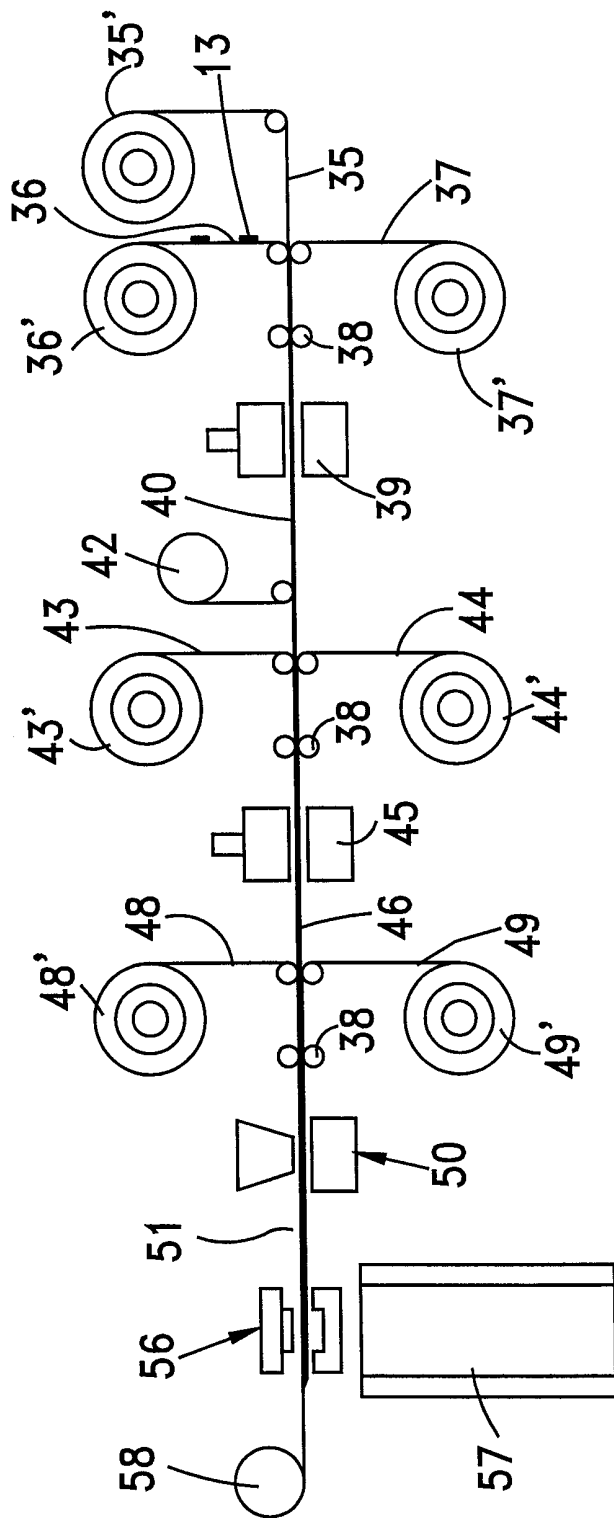

Fig. 4

4/8

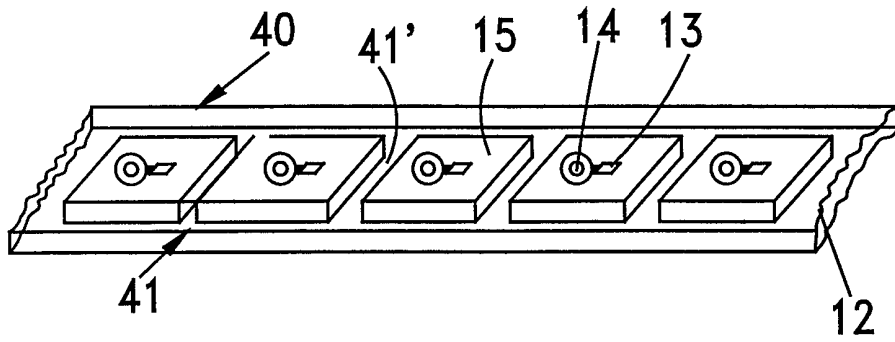

Fig. 5

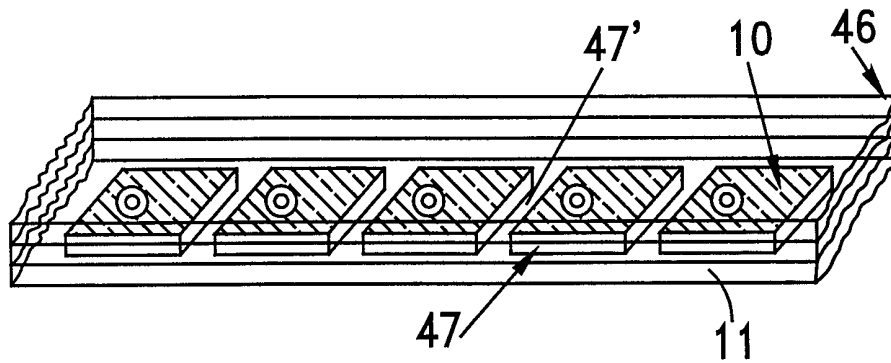

Fig. 6

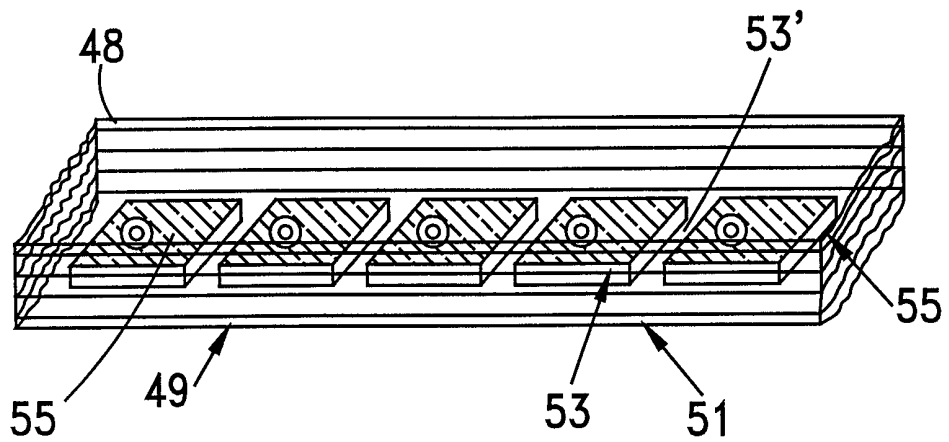

Fig. 7

5/8

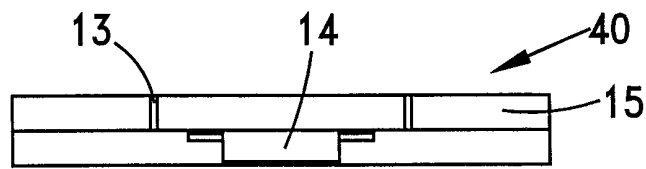

Fig. 8

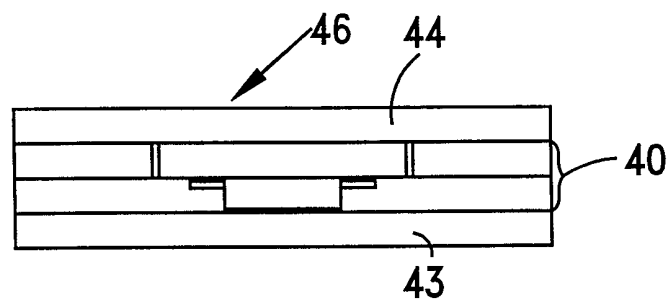

Fig. 9

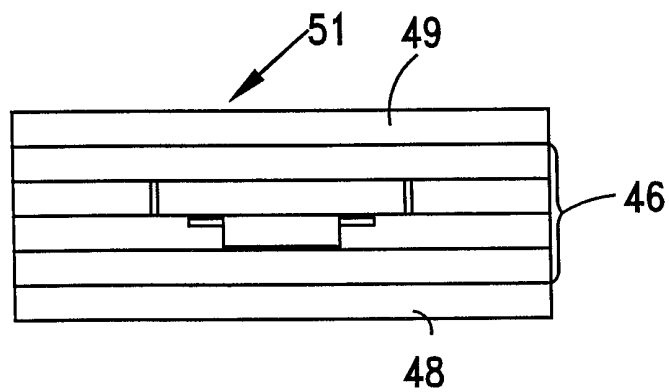

Fig. 10

6/8

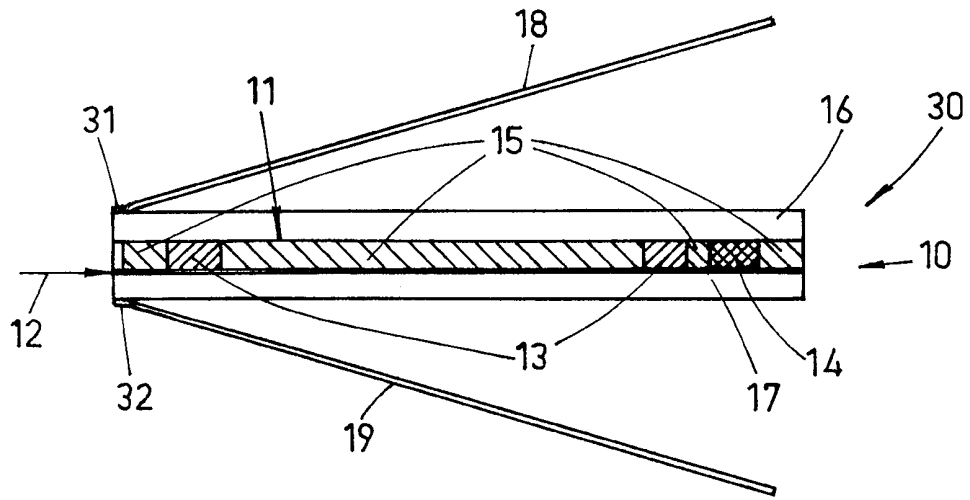

Fig. 11

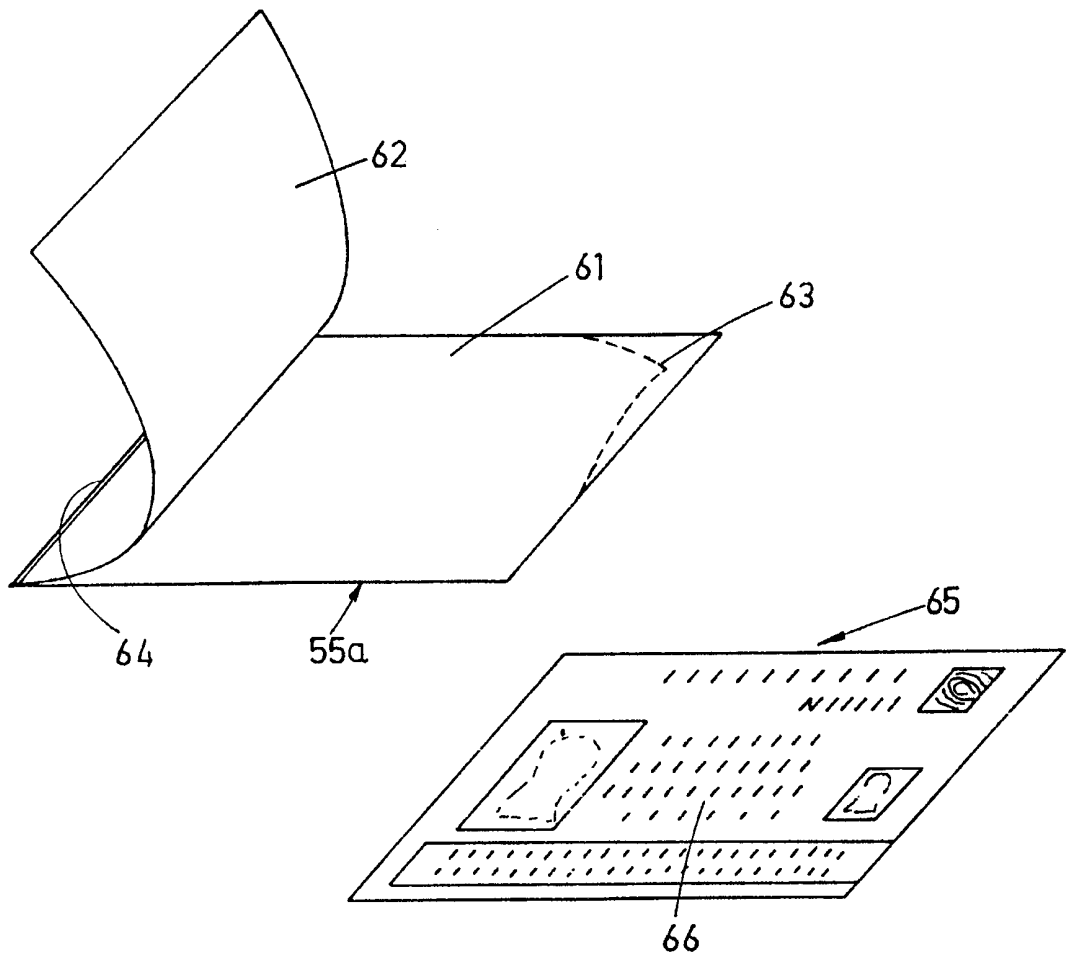

Fig. 12

7/8

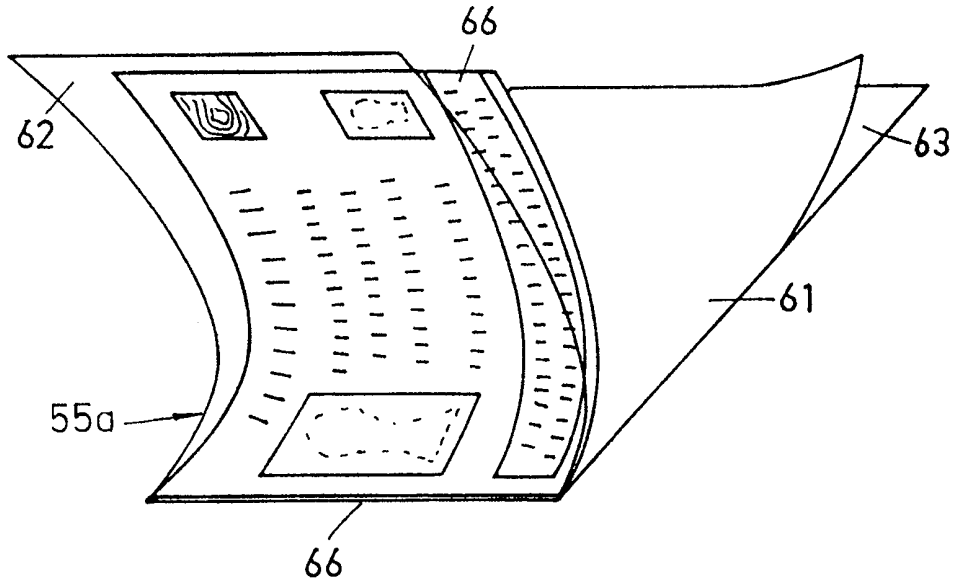

Fig. 13

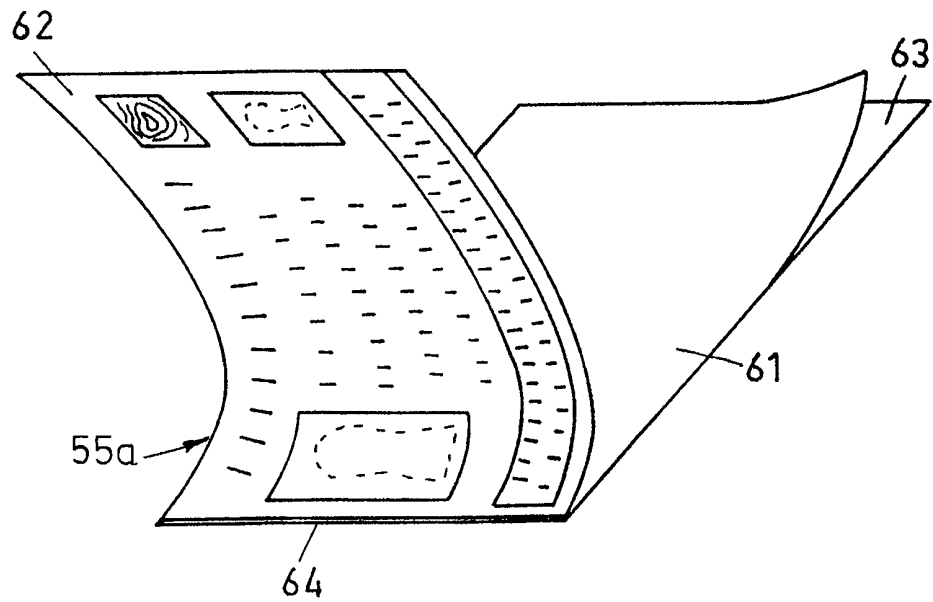

Fig. 14

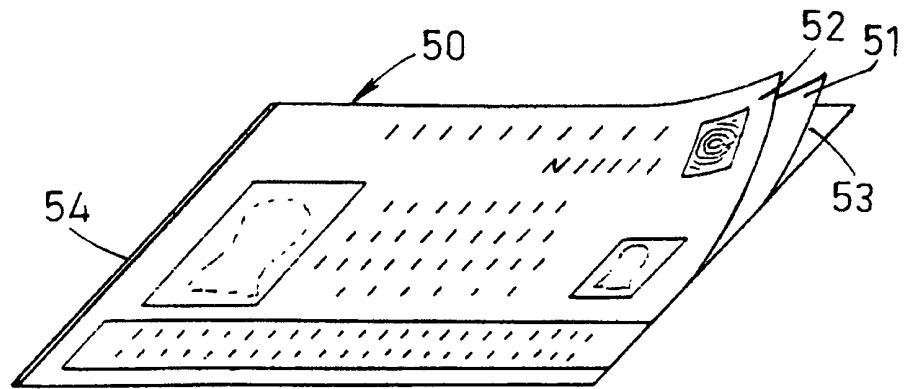

Fig. 15

# INTERNATIONAL SEARCH REPORT

International Application No

PCT/IL 98/00549

**A. CLASSIFICATION OF SUBJECT MATTER**  
IPC 6 G06K19/077

According to International Patent Classification (IPC) or to both national classification and IPC

**B. FIELDS SEARCHED**

Minimum documentation searched (classification system followed by classification symbols)  
IPC 6 G06K

Documentation searched other than minimum documentation to the extent that such documents are included in the fields searched

Electronic data base consulted during the international search (name of data base and, where practical, search terms used)

**C. DOCUMENTS CONSIDERED TO BE RELEVANT**

Category *	Citation of document, with indication, where appropriate, of the relevant passages	Relevant to claim No.
X	GB 2 279 612 A (GEC AVERY LTD) 11 January 1995 see page 4, paragraph 4 - page 9, paragraph 1 see figure 11 -----	1-37
A	WO 92 21105 A (SKIDATA COMPUTER GES MBH) 26 November 1992 see page 6, line 32 - page 7, line 24 see page 7, line 34 - page 8, line 26 -----	1-37
A	EP 0 638 873 A (DAINIPPON PRINTING CO LTD) 15 February 1995 see column 34, line 33 - line 41 -----	1, 14

Further documents are listed in the continuation of box C.

Patent family members are listed in annex.

\* Special categories of cited documents :

- "A" document defining the general state of the art which is not considered to be of particular relevance
- "E" earlier document but published on or after the international filing date
- "L" document which may throw doubts on priority claim(s) or which is cited to establish the publication date of another citation or other special reason (as specified)
- "O" document referring to an oral disclosure, use, exhibition or other means
- "P" document published prior to the international filing date but later than the priority date claimed

- "T" later document published after the international filing date or priority date and not in conflict with the application but cited to understand the principle or theory underlying the invention
- "X" document of particular relevance; the claimed invention cannot be considered novel or cannot be considered to involve an inventive step when the document is taken alone
- "Y" document of particular relevance; the claimed invention cannot be considered to involve an inventive step when the document is combined with one or more other such documents, such combination being obvious to a person skilled in the art.
- "&" document member of the same patent family

Date of the actual completion of the international search

3 March 1999

Date of mailing of the international search report

10/03/1999

Name and mailing address of the ISA

European Patent Office, P.B. 5818 Patentlaan 2  
NL - 2280 HV Rijswijk  
Tel. (+31-70) 340-2040, Tx. 31 651 epo nl,  
Fax: (+31-70) 340-3016

Authorized officer

Goossens, A

# INTERNATIONAL SEARCH REPORT

Information on patent family members

International Application No

PCT/IL 98/00549

Patent document cited in search report		Publication date	Patent family member(s)	Publication date
GB 2279612	A	11-01-1995	NONE	
WO 9221105	A	26-11-1992	AT 98691 A EP 0749614 A JP 6508945 T	15-08-1994 27-12-1996 06-10-1994
EP 0638873	A	15-02-1995	JP 7276870 A US 5581065 A US 5757116 A	24-10-1995 03-12-1996 26-05-1998