



US00D506349S

(12) **United States Design Patent**  
Wasserman et al.

(10) **Patent No.:** **US D506,349 S**

(45) **Date of Patent:** **\*\* Jun. 21, 2005**

(54) **CHAFFER**

(75) Inventors: **David M. Wasserman**, Whitefish Bay, WI (US); **John A. Wojcik**, Sheboygan, WI (US); **Ronald E. Bratton**, Fort Wayne, IN (US); **William C. Lindeman**, Marshall, WI (US); **Cory R. Boudreau**, Madison, WI (US); **David E. Barnard**, Saint Paul, MN (US)

(73) Assignee: **Oshkosh Truck Corporation**, Oshkosh, WI (US)

(\*\*) Term: **14 Years**

(21) Appl. No.: **29/193,278**

(22) Filed: **Nov. 6, 2003**

(51) **LOC (8) Cl.** ..... **07-02**

(52) **U.S. Cl.** ..... **D7/355; D7/366**

(58) **Field of Search** ..... **D7/323, 354-361, D7/365-367; 99/324, 339, 340, 357; 219/620-622, 429-438, 451.1; 220/573.1-574, 252; 248/147**

(56) **References Cited**

**U.S. PATENT DOCUMENTS**

D29,879 S	12/1898	Wojcikow	
D42,277 S	3/1912	Farr	
D91,774 S	3/1934	Fukal	
D146,832 S	* 5/1947	O'Connell	..... D7/355
D150,157 S	7/1948	O'Connell	
D169,166 S	3/1953	O'Connell	

D176,993 S	2/1956	O'Connell	
D213,717 S	* 4/1969	Rickmeier, Jr.	..... D7/355
D369,506 S	* 5/1996	Tinius	..... D7/355
D401,804 S	* 12/1998	Tinius	..... D7/355
D423,278 S	4/2000	Briner	
D426,103 S	* 6/2000	Briner	..... D7/355
D433,272 S	11/2000	Park	
D437,181 S	* 2/2001	Park	..... D7/355
D488,669 S	* 4/2004	Tse	..... D7/355

\* cited by examiner

*Primary Examiner*—Caron D. Veynar

(74) *Attorney, Agent, or Firm*—Foley & Lardner LLP

(57) **CLAIM**

We claim the ornamental design for a chaffer, as shown and described.

**DESCRIPTION**

FIG. 1 is a top perspective view of one embodiment of design for a chaffer of the present invention; FIG. 2 is a top plan view thereof; FIG. 3 is a front elevational view thereof; FIG. 4 is a right end elevational view thereof, the left end elevational view being a mirror image of the right end elevational view shown; FIG. 5 is a rear elevational view thereof; and, FIG. 6 is a bottom plan view thereof.

The ornamental design which is claimed is shown in solid lines in the drawings. The broken lines in the drawings are for illustrative purposes only and form no part of the claimed design.

**1 Claim, 6 Drawing Sheets**

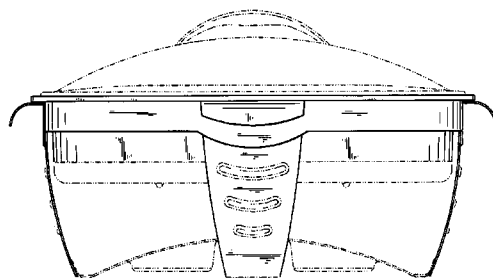
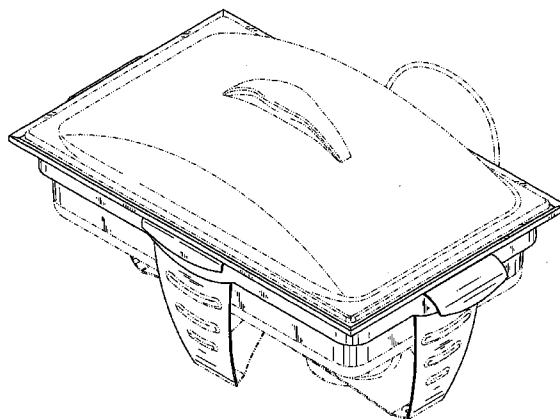
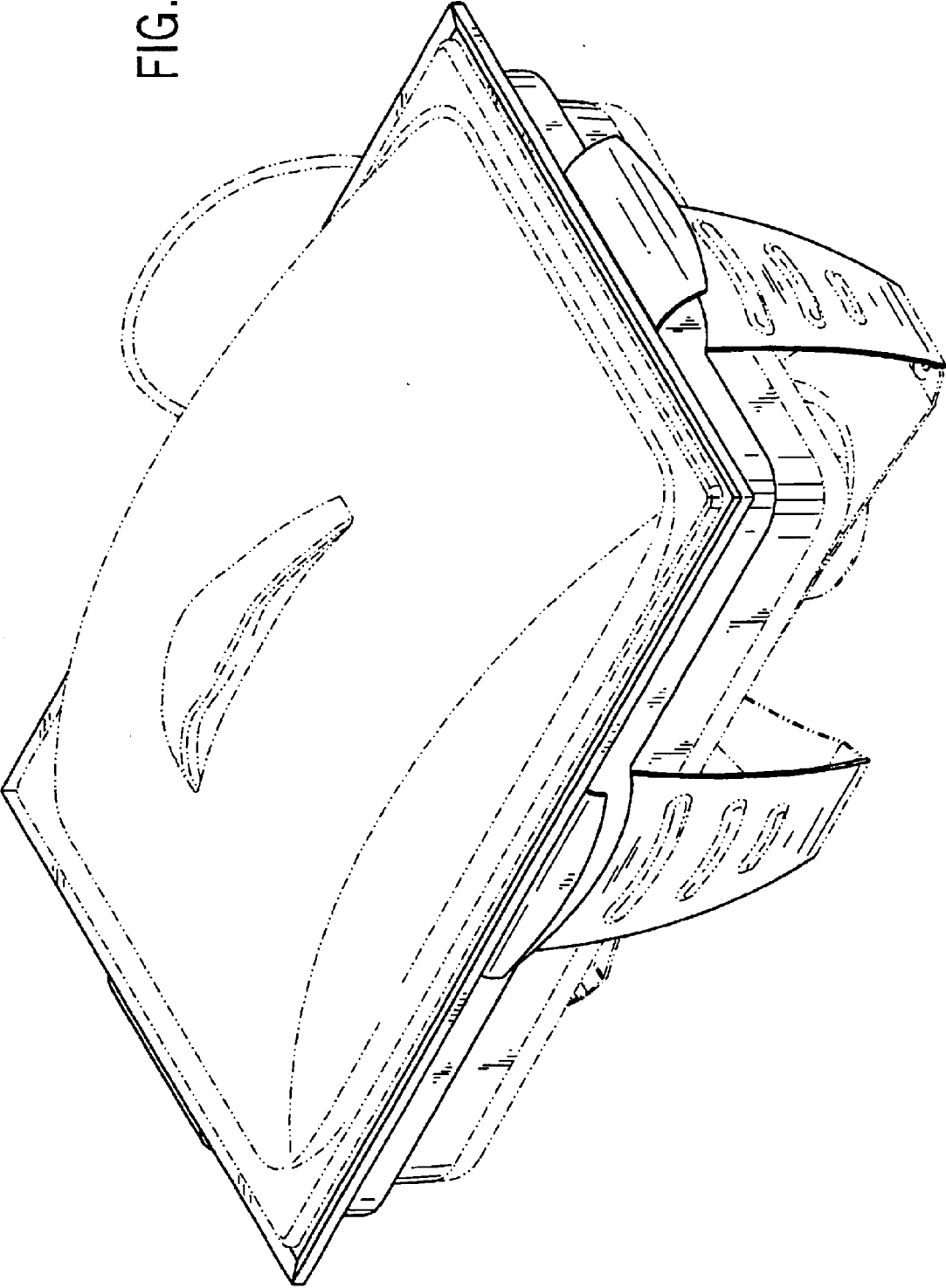

FIG. 1



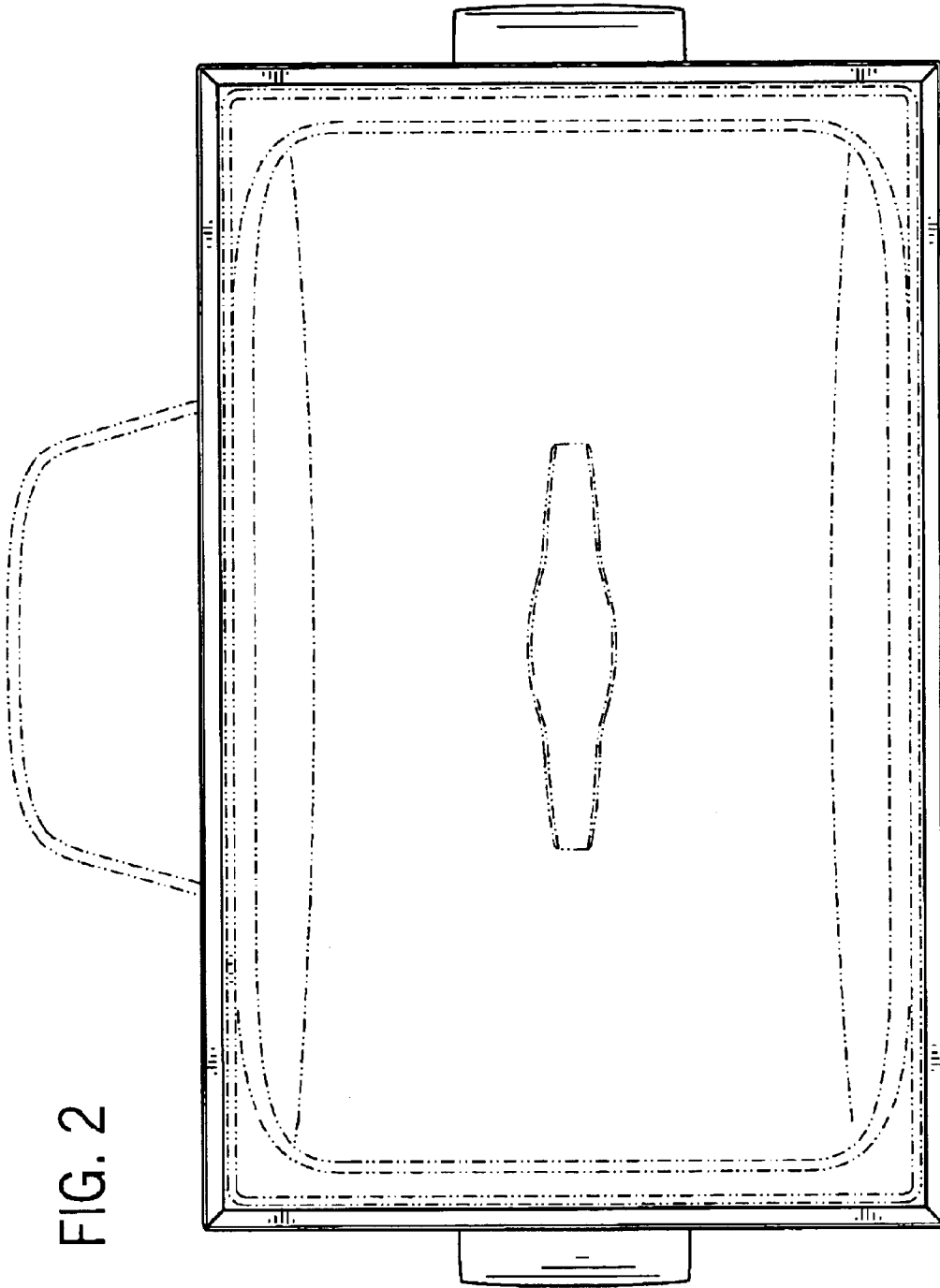

FIG. 2

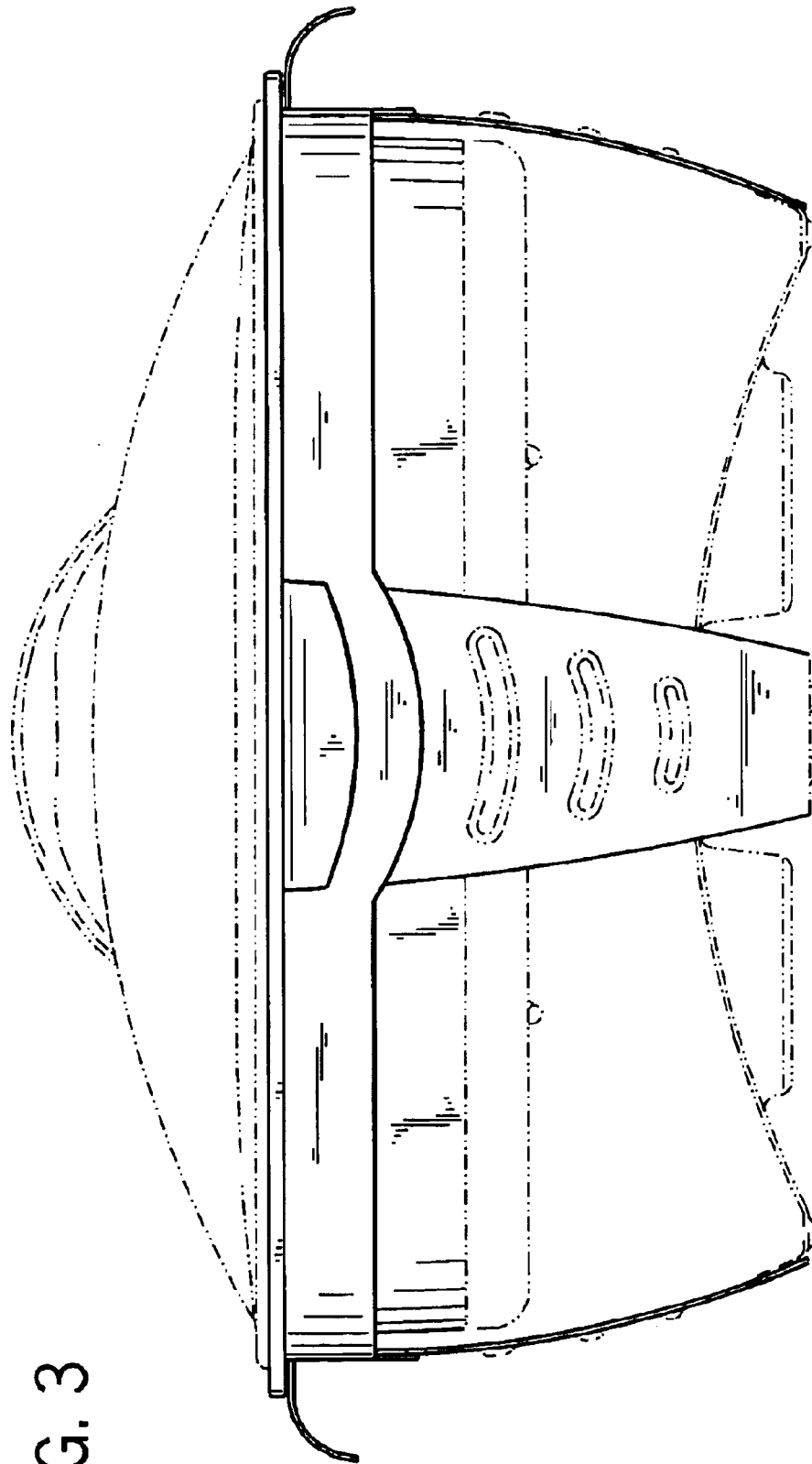

FIG. 3

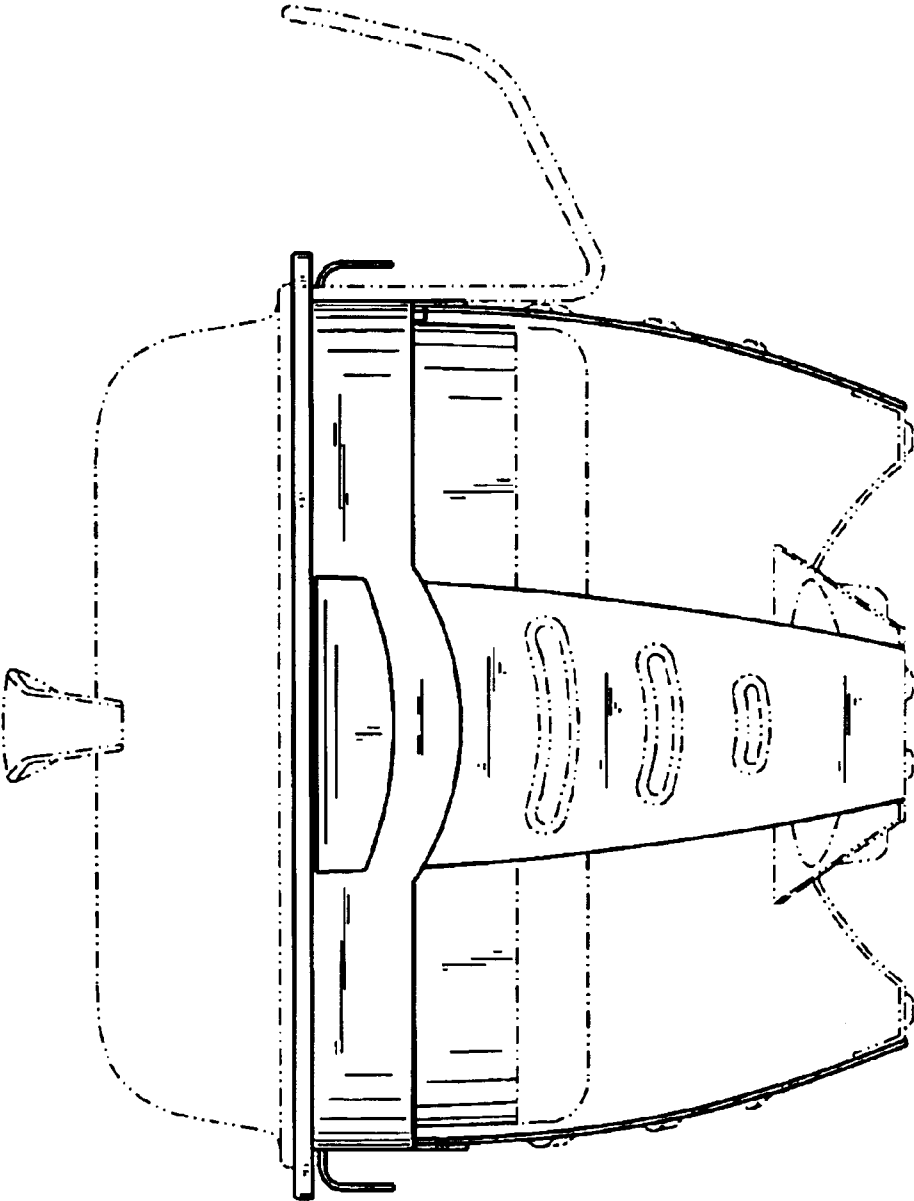

FIG. 4

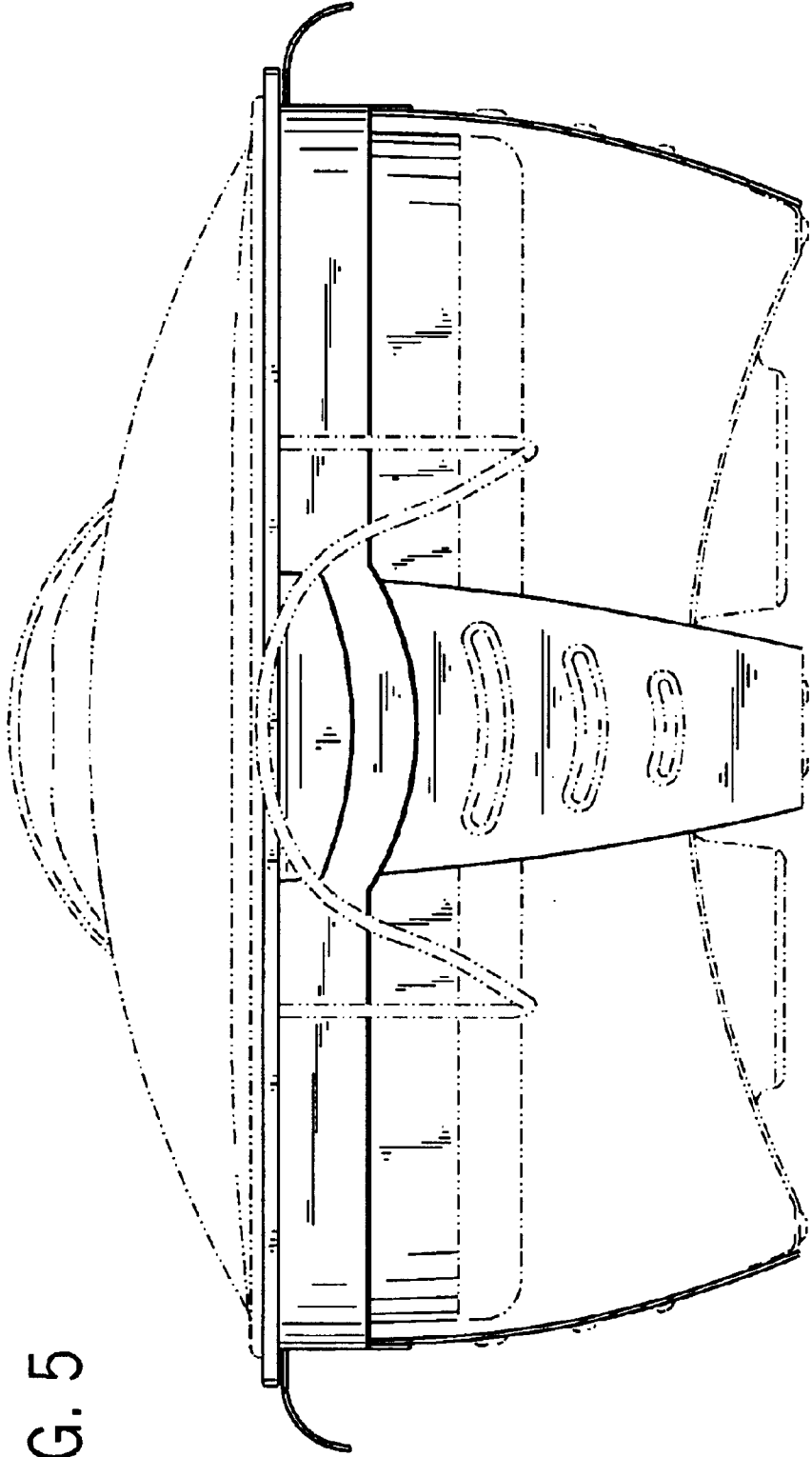

FIG. 5

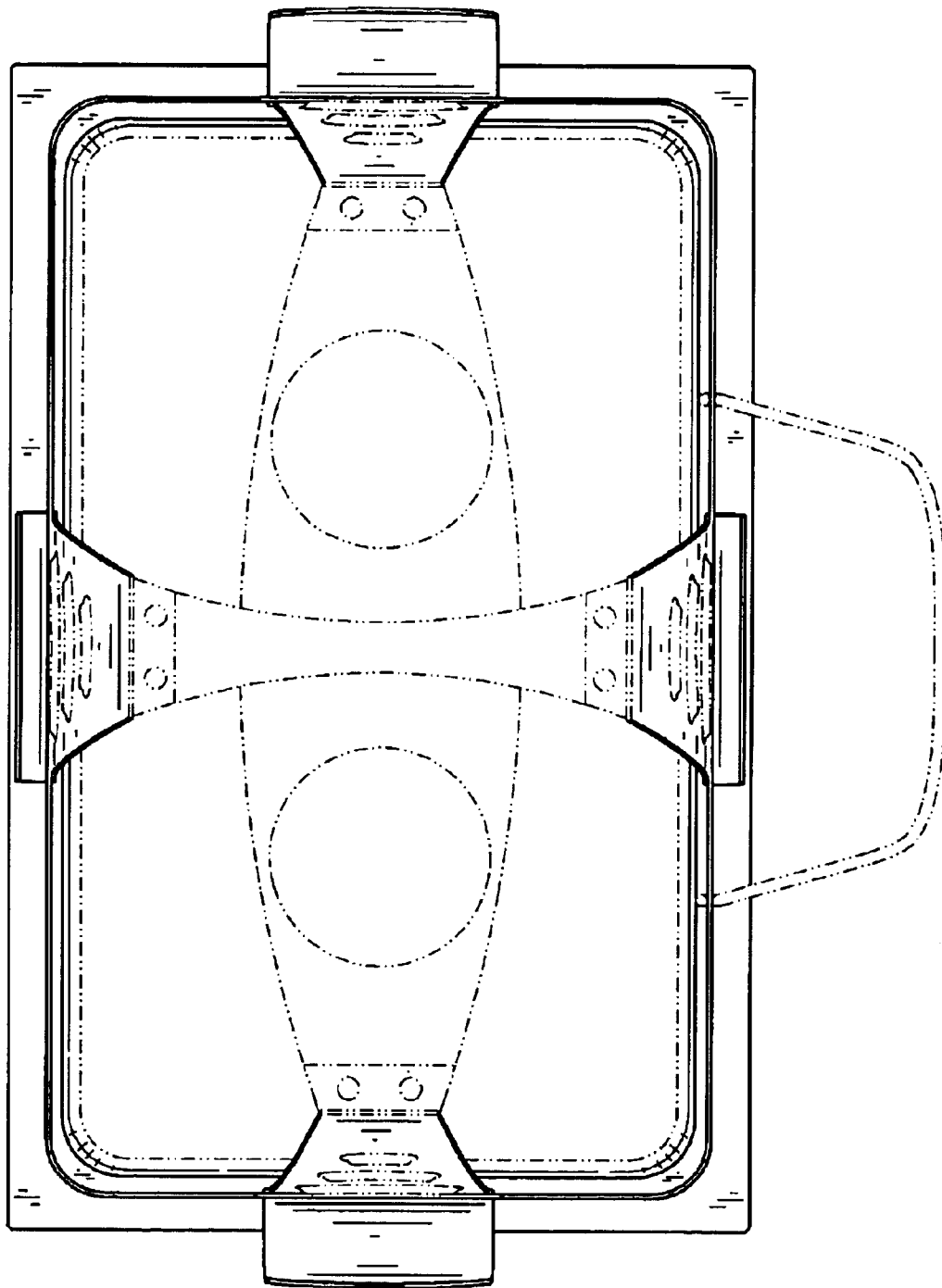

FIG. 6

UNITED STATES PATENT AND TRADEMARK OFFICE  
**CERTIFICATE OF CORRECTION**

PATENT NO. : Des. 506,349 S  
DATED : June 21, 2005  
INVENTOR(S) : David M. Wasserman et al.

Page 1 of 1

It is certified that error appears in the above-identified patent and that said Letters Patent is hereby corrected as shown below:

Title page,

Item [73], Assignee, should read -- **The Vollrath Company, L.L.C.** --.

Signed and Sealed this

Fourth Day of October, 2005

A handwritten signature in black ink on a light gray dotted background. The signature reads "Jon W. Dudas" in a cursive style.

JON W. DUDAS

*Director of the United States Patent and Trademark Office*