



US00D764951S

(12) **United States Design Patent** (10) **Patent No.:** **US D764,951 S**
Cheng (45) **Date of Patent:** **** Aug. 30, 2016**

(54) **TIMER**
(71) Applicant: **Chi Han Cheng**, Changhua (TW)
(72) Inventor: **Chi Han Cheng**, Changhua (TW)
(73) Assignee: **Yuan Mei Corp.**, Chang Hua Hsien (TW)
(**) Term: **14 Years**

(21) Appl. No.: **29/517,217**

(22) Filed: **Feb. 11, 2015**

(51) **LOC (10) CL.** **10-03**

(52) **U.S. CL.**
USPC **D10/40**

(58) **Field of Classification Search**
USPC D10/40, 122; D13/162.1; D23/245, 246
CPC A01G 25/00; A01G 25/16; A01G 25/162;
A01G 25/165; B05B 12/00; B05B 12/02;
F16K 31/48; G05D 7/00; G05D 7/06; G05D
7/0635; G04F 3/00; G04F 3/02
See application file for complete search history.

(56) **References Cited**

U.S. PATENT DOCUMENTS

53,726 A	4/1866	Ball
1,865,965 A	3/1927	Ruiz
D191,294 S	9/1961	Charnota et al.
D212,154 S	9/1968	Benjamin
D234,603 S	3/1975	Snow et al.
D269,697 S	7/1983	Graham et al.
4,562,865 A	1/1986	Lemkin et al.
D282,446 S	2/1986	Gremontprez et al.
D295,778 S	5/1988	Bruninga et al.
4,807,664 A	2/1989	Wilson et al.
D309,175 S	7/1990	Hastings et al.
4,951,204 A	8/1990	Mylne, III
5,135,168 A	8/1992	Wang
5,262,936 A	11/1993	Faris et al.
D365,771 S	1/1996	Clivio
D368,230 S	3/1996	Cohen et al.

D377,316 S	1/1997	Roman et al.	
D386,985 S	12/1997	Cameron	
D427,085 S	6/2000	Steinhagen	
D431,195 S	9/2000	Clivio	
D452,695 S	1/2002	Miller	
D467,187 S	12/2002	Clivio	
D476,240 S	6/2003	Kuramochi et al.	
D485,502 S	1/2004	Clivio	
D492,264 S	6/2004	Perez et al.	
D507,243 S	7/2005	Miller	
D535,571 S	1/2007	Simon et al.	
D535,895 S	1/2007	Simon et al.	
7,225,057 B2	5/2007	Froman et al.	
D559,708 S *	1/2008	Michael	D10/40
D567,680 S *	4/2008	Michael	D10/40
D567,681 S	4/2008	Michael et al.	

(Continued)

OTHER PUBLICATIONS

The Toro Company, ECXTRA™ Automatic Sprinkler System Control Timer User's Guide, © 2004, 44 pages, Form No. 373-0339 Rev. A.

Primary Examiner — Sandra Snapp
(74) *Attorney, Agent, or Firm* — Senniger Powers LLP

(57) **CLAIM**
The ornamental design for a timer, as shown and described.

DESCRIPTION

FIG. 1 is a right front perspective view of a timer showing our new design;
FIG. 2 is a front elevational view thereof;
FIG. 3 is a rear elevational view thereof;
FIG. 4 is a left side elevational view thereof;
FIG. 5 is a right side elevational view thereof;
FIG. 6 is a top plan view thereof; and,
FIG. 7 is a bottom plan view thereof.
The structural features depicted by broken lines in the drawings have been shown for the purpose of illustrating portions of the timer that form no part of the claimed design.

1 Claim, 7 Drawing Sheets

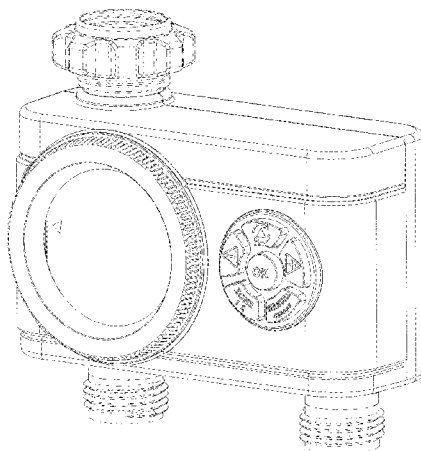

(56)

References Cited

U.S. PATENT DOCUMENTS

D608,301 S 1/2010 Clark et al.
 D636,278 S 4/2011 Franchini
 D642,077 S * 7/2011 Nies D10/40
 D643,755 S * 8/2011 Nies D10/40
 D647,411 S * 10/2011 Barton D10/40
 D657,263 S * 4/2012 Nies D10/40
 D657,264 S * 4/2012 Nies D10/40
 8,160,750 B2 4/2012 Weiler
 D658,519 S 5/2012 Connolly et al.
 D659,029 S * 5/2012 Connolly D10/122
 8,251,300 B2 8/2012 Wilson
 D671,847 S 12/2012 Chandran et al.
 D671,849 S 12/2012 Chandran et al.
 D679,259 S 4/2013 Franchini

D679,260 S 4/2013 Franchini
 D682,714 S * 5/2013 Barton D10/40
 D691,966 S 10/2013 Stossell
 D702,566 S * 4/2014 Chandran D10/10
 D713,270 S * 9/2014 Chandran D10/40
 D713,271 S * 9/2014 Ericksen D10/40
 D736,104 S 8/2015 Ericksen et al.
 D750,506 S 3/2016 Ericksen et al.
 D750,977 S 3/2016 Ericksen et al.
 2006/0011243 A1 * 1/2006 Jacobs F16K 31/48
 137/624.11
 2009/0001193 A1 1/2009 Parsons et al.
 2010/0230510 A1 * 9/2010 Wilson A01G 25/165
 239/70
 2011/0089351 A1 * 4/2011 Spadotto A01G 25/165
 251/129.15

* cited by examiner

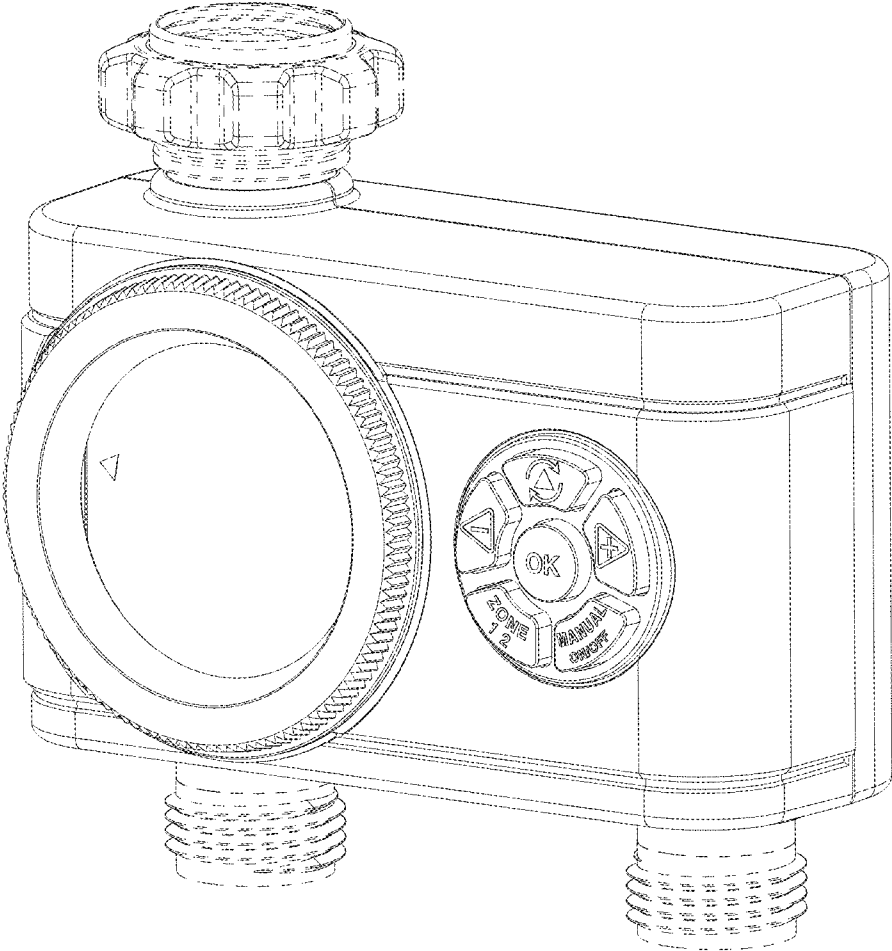

FIG. 1

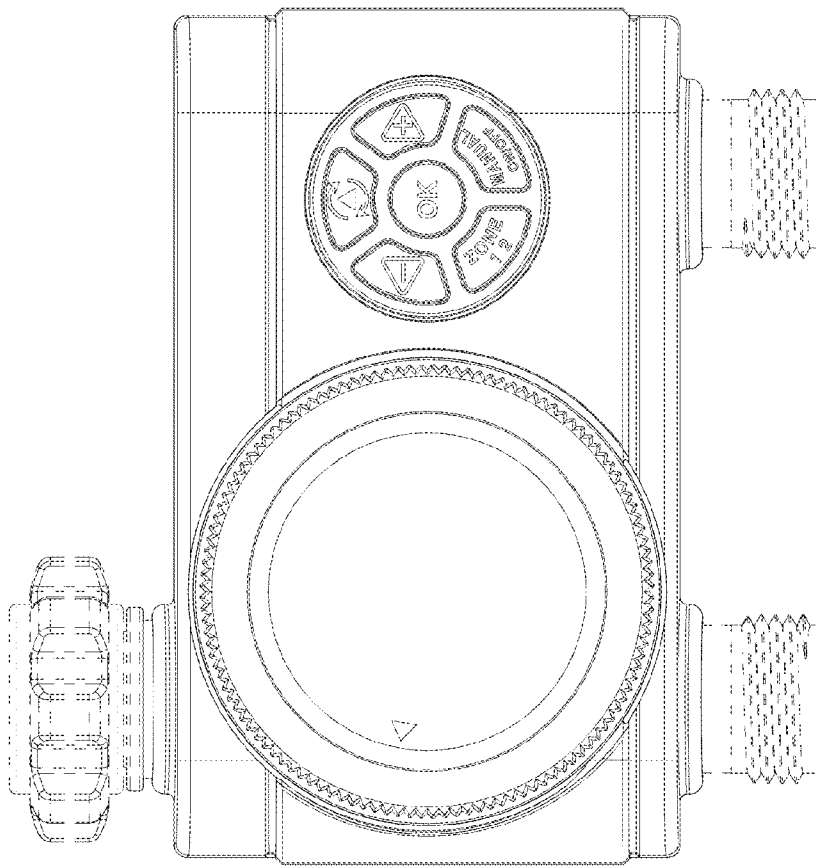

FIG. 2

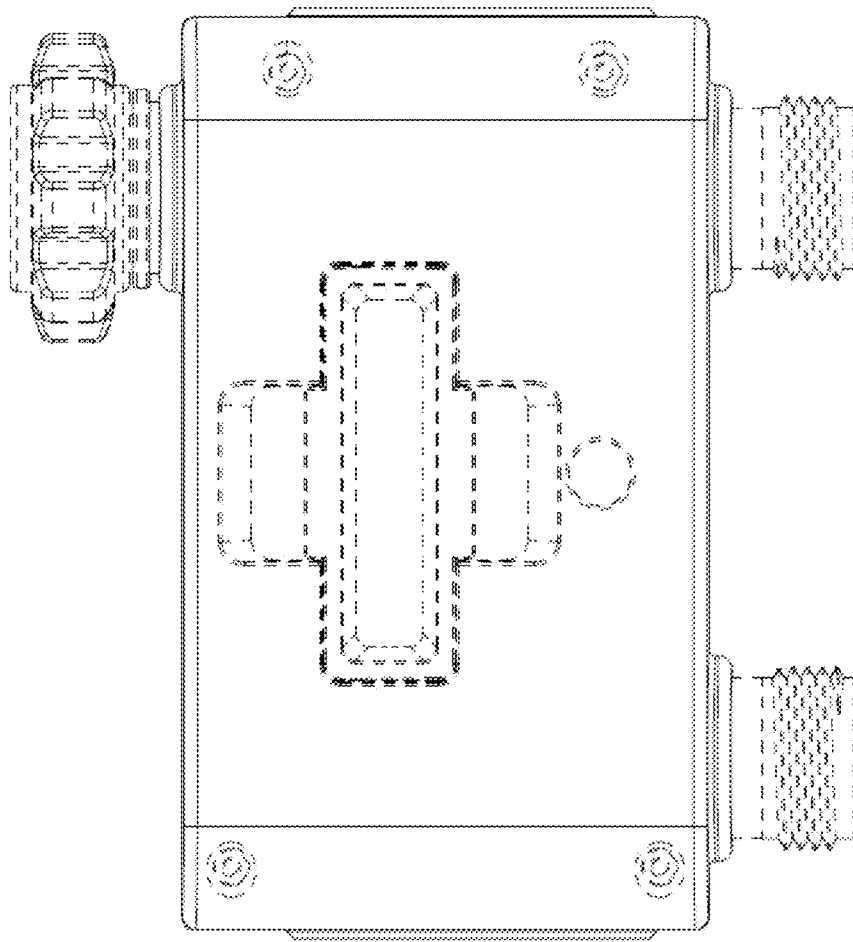

FIG. 3

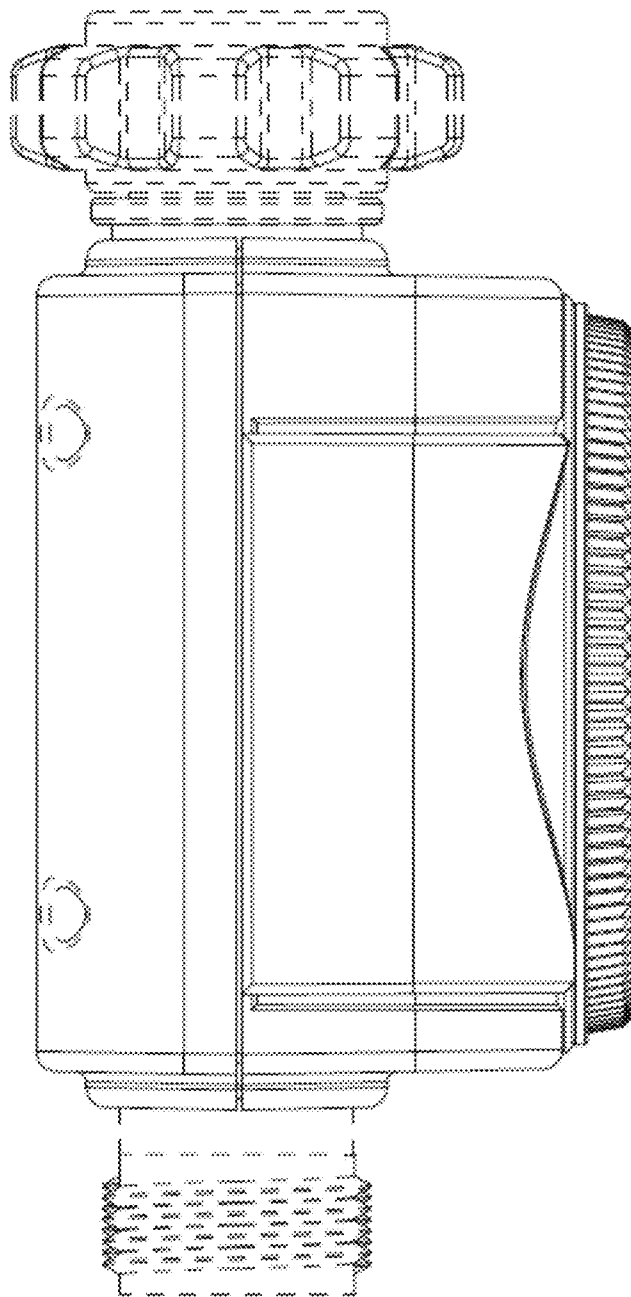

FIG. 4

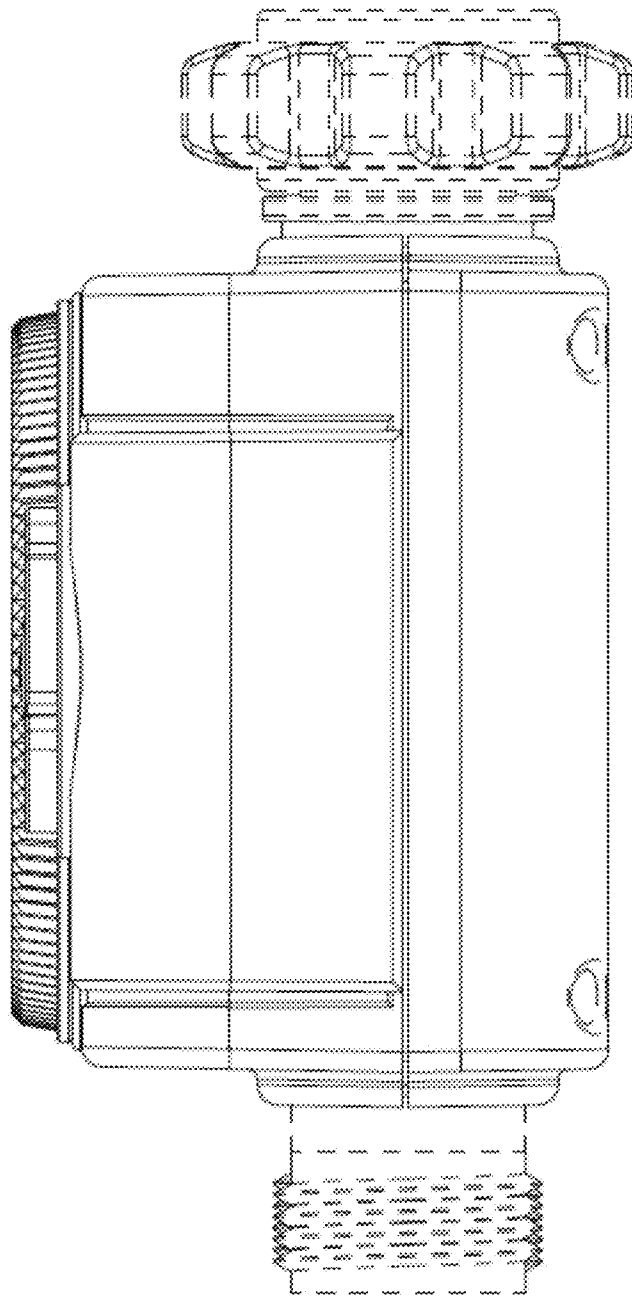

FIG. 5

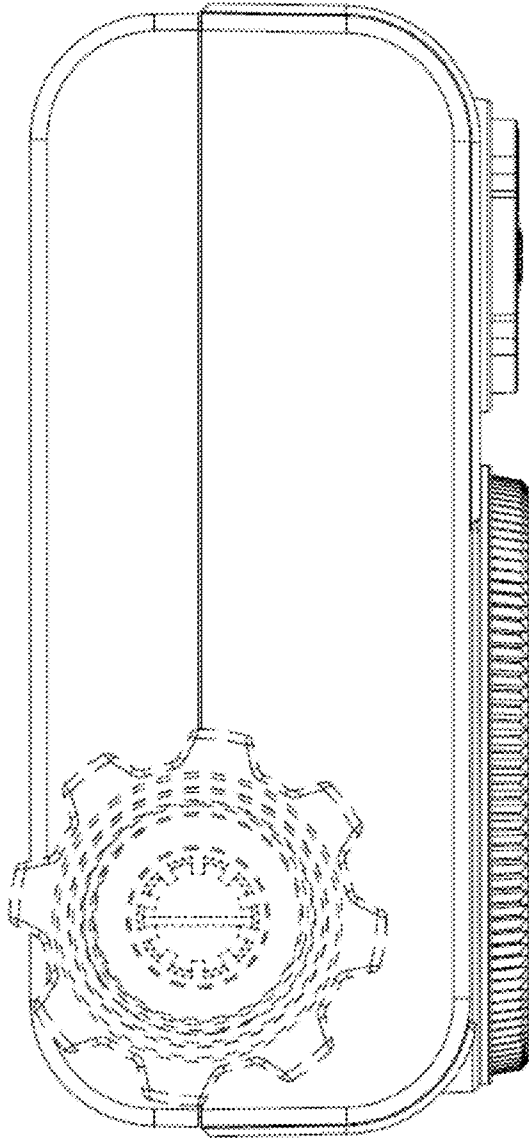

FIG. 6

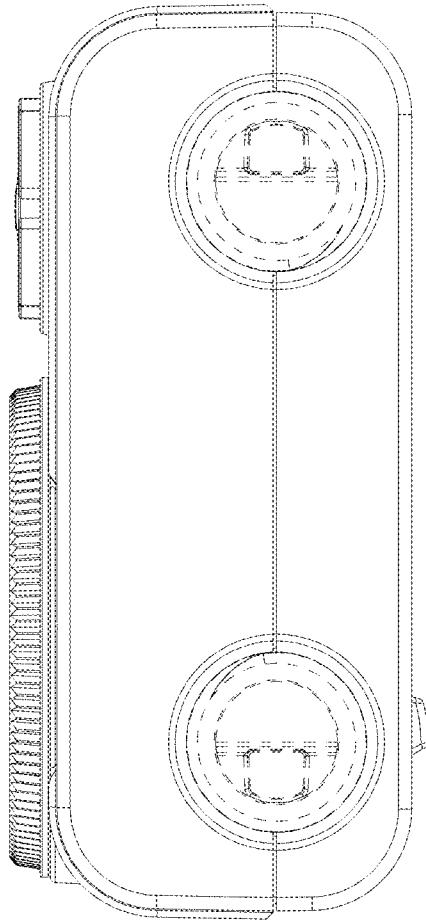

FIG. 7