



INTERNATIONAL APPLICATION PUBLISHED UNDER THE PATENT COOPERATION TREATY (PCT)

<p>(51) International Patent Classification⁵ : B65D 81/16</p>	<p>A1</p>	<p>(11) International Publication Number: WO 94/25369</p> <p>(43) International Publication Date: 10 November 1994 (10.11.94)</p>
<p>(21) International Application Number: PCT/DK93/00309</p> <p>(22) International Filing Date: 24 September 1993 (24.09.93)</p> <p>(30) Priority Data: 0519/93 5 May 1993 (05.05.93) DK</p> <p>(71) Applicant (for all designated States except US): BRØDRENE HARTMANN A/S [DK/DK]; Klampenborgvej 203-205, DK-2800 Lyngby (DK).</p> <p>(72) Inventor; and (75) Inventor/Applicant (for US only): BERTELSEN, Svend [DK/DK]; Espens Vænge 20, DK-2630 Tåstrup (DK).</p> <p>(74) Agent: BUDDE, SCHOU & CO. A/S; Sundkrogs-gade 10, DK-2100 København Ø (DK).</p>		<p>(81) Designated States: AT, AU, BB, BG, BR, BY, CA, CH, CZ, DE, DK, ES, FI, GB, HU, JP, KP, KR, KZ, LK, LU, LV, MG, MN, MW, NL, NO, NZ, PL, PT, RO, RU, SD, SE, SK, UA, US, UZ, European patent (AT, BE, CH, DE, DK, ES, FR, GB, GR, IE, IT, LU, MC, NL, PT, SE), OAPI patent (BF, BJ, CF, CG, CI, CM, GA, GN, ML, MR, NE, SN, TD, TG).</p> <p>Published With international search report. With amended claims and statement.</p>
<p>(54) Title: PACKAGING ELEMENT MADE FROM PULP MATERIAL</p>		
<p>(57) Abstract</p> <p>In a packaging element in the form of a shell of pulp material for supporting an end part and/or side part of a preferably box-shaped article (G) being packaged in a shipping package, said packaging element (1, 101) comprising a supporting surface (3, 103) spaced from a basis surface (2, 102) as well as a number of projections (4, 5, 6, 104, 105, 106) projecting beyond the level of said supporting surface for partially embracing the end part and/or side of said article (G), the main novel feature is that the packaging element (1, 101) is symmetrical about a transverse plane at right angles through the center of the rectangular base surface (2, 102) and asymmetrical about a longitudinal plane at right angles through the center of the base surface (2, 102), said element (1, 101) at each end of the mainly rectangular supporting surface (3, 103) comprising two projections (4, 5, 104, 105) protruding to the same height above said supporting surface, viz. a first projection (4, 104) extending along the shorter side of the supporting surface (3, 103) and a second projection (5, 105) extending along the first projection (4, 104) and the longer side of the supporting surface (3, 103).</p>		

FOR THE PURPOSES OF INFORMATION ONLY

Codes used to identify States party to the PCT on the front pages of pamphlets publishing international applications under the PCT.

AT	Austria	GB	United Kingdom	MR	Mauritania
AU	Australia	GE	Georgia	MW	Malawi
BB	Barbados	GN	Guinea	NE	Niger
BE	Belgium	GR	Greece	NL	Netherlands
BF	Burkina Faso	HU	Hungary	NO	Norway
BG	Bulgaria	IE	Ireland	NZ	New Zealand
BJ	Benin	IT	Italy	PL	Poland
BR	Brazil	JP	Japan	PT	Portugal
BY	Belarus	KE	Kenya	RO	Romania
CA	Canada	KG	Kyrgystan	RU	Russian Federation
CF	Central African Republic	KP	Democratic People's Republic of Korea	SD	Sudan
CG	Congo	KR	Republic of Korea	SE	Sweden
CH	Switzerland	KZ	Kazakhstan	SI	Slovenia
CI	Côte d'Ivoire	LI	Liechtenstein	SK	Slovakia
CM	Cameroon	LK	Sri Lanka	SN	Senegal
CN	China	LU	Luxembourg	TD	Chad
CS	Czechoslovakia	LV	Latvia	TG	Togo
CZ	Czech Republic	MC	Monaco	TJ	Tajikistan
DE	Germany	MD	Republic of Moldova	TT	Trinidad and Tobago
DK	Denmark	MG	Madagascar	UA	Ukraine
ES	Spain	ML	Mali	US	United States of America
FI	Finland	MN	Mongolia	UZ	Uzbekistan
FR	France			VN	Viet Nam
GA	Gabon				

PACKAGING ELEMENT MADE FROM PULP MATERIAL.TECHNICAL FIELD

5 The present invention relates to a packaging element of the kind set forth in the preamble of claim 1.

BACKGROUND ART

10 As described in our parallel DK patent application no. 1186/92, packaging elements of the kind referred to above are used for supporting and protecting mainly box-shaped articles, such as electronic apparatus, e.g. transistor receivers and amplifiers, when placed in an outer packaging
15 element like a corrugated-paper box, during transportation and handling, said elements not only locating the article in the outer packaging, but they also protect it against impact during transportation and handling.

20 The previously known packaging elements are adapted each to embrace an end part or a side part of the article, so that two such packaging elements, one at each end part or side part of the article, position the articles in the outer packaging and protect it against impact.

25

DISCLOSURE OF THE INVENTION

It is the object of the present invention to provide a packaging element of the kind referred to initially, that is
30 shaped in such a manner, that two such packaging elements placed along to opposite side edges of an article can cooperate with two similar packaging elements placed along opposite end edges of the article so as to position the article in an outer packaging element and protect it against impact.

35

This object is achieved by means of the features set forth

in the characterizing clause of claim 1.

5 With this arrangement, two packaging elements can be placed with one along each of the two opposing, e.g. lower, side edges of an article, while two similar packaging elements can be placed transversely of the first elements along each of the two, e.g. upper, end edges of the article, so that the projections on the two sets of packaging elements cooperate in embracing and protecting the corner edges of the article as well as the latter's side edges and end edges in the corner regions, the packaging elements additionally being able to position the article lying firmly and safely in an outer package, such as a corrugated-paper box.

15 The packaging element according to the present invention is preferably shaped in the manner set forth in claim 2, this making it possible to secure the two sets of packaging elements to each other about the article prior to the placing of the latter and the packaging element in an outer packaging element, such as a corrugated-paper box. If so, the complementary locking members may have the shape set forth in claims 3 and 4.

BRIEF DESCRIPTION OF THE DRAWINGS

25 In the following detailed portion of the present description, the present invention will be explained in more detail with reference to the exemplary embodiments of packaging elements according to the invention shown in the drawings, in which

Fig. 1 in perspective shows a packaging element with locking means in the form of locking studs,

35 Fig. 2 in perspective shows a packaging element with locking means in the form of recesses complementary to the locking

studs shown in Fig. 1, and

Fig. 3 in perspective shows packaging elements of the kind shown in Figs. 1 and 2, placed along the end edges and side edges of a box-shaped article.

DESCRIPTION OF THE PREFERRED EMBODIMENT

In Fig. 1, a packaging element according to the present invention is generally designated 1. The packaging element 1 has a rectangular base surface 2 and, spaced from this surface, a mainly rectangular supporting surface 3. The packaging element 1 is symmetrical about a plane extending transversely and at right angles through the center of the base surface 2, but is asymmetrical about a plane extending longitudinally and at right angles through the center of this base surface. At each end of the supporting surface 3, two projections 4 and 5 protrude to the same height above the supporting surface 3, one projection 4 extending along the shorter side of the supporting surface 3, and the other projection 5 extending along the first projection 4 and along the longer side of the supporting surface 3.

In the middle between the two projections 5 at each end of the longer side of the supporting surface 3, there is at least one further projection 6 having the same height above the supporting surface 3 as the projections 4 and 5 and facing the latter.

Locking studs 7 and 8 on top of each of the projections 4 and 5 are placed symmetrically about a plane extending transversely and at right angles through the center of the base surface 2. In the exemplary embodiment of the packaging element 1 shown, the locking studs 7 and 8 are frusto-conical with a circular cross-sectional shape, but it will be appreciated that they may have some other shape, i.e. frusto-

pyramidal with a square cross-sectional shape.

Likewise, it will be appreciated that on top of each of the projections 5, a further locking stud could be placed adjacent to the locking stud 8 and together with the latter situated symmetrically about a longitudinal plane at right angles to the base surface 2, the center-line distance between this further locking stud and the locking stud 8 being the same as the center-line distance between the locking studs 7 and 8.

For the packaging element according to the present invention shown in Fig. 2, the same reference numerals are used as in Fig. 1 for mutually corresponding or complementary details, but with the number 100 added.

The packaging element 101 has a rectangular base surface 102, and spaced from the latter a mainly rectangular supporting surface 103, the element being symmetrical about a transverse plane extending at right angles through the center of the base surface 102 and asymmetrical about a longitudinal plane extending at right angles through the center of this base surface. At each end of the supporting surface 103, two projections 104 and 105 protrude to the same height above the supporting surface 103, one projection 104 extending along the shorter side of the supporting surface 103, and the other projection 105 extending along the first projection 104 and along the longer side of the supporting surface 103.

In the middle between the two projections 105 at each end of the supporting surface 103 there is at least one further projection 106 having the same height above the supporting surface 103 as the projections 104 and 105.

In the top of each of the projections 105 and placed symmetrically about a longitudinal plane at right angles to the base surface 102 there are two dowel-hole-shaped locking recesses 107 and 108, the center-line spacing of which is equal to the center-line spacing between the locking studs 7 and 8 on the packaging element 1 shown in Fig. 1, said recesses 107 and 108 being complementary in shape to the locking studs 7 and 8, i.e. in the exemplary embodiment shown frusto-conical recesses with such dimensions, that each of them can receive one of the locking studs 7 or 8 on the packaging element 1 shown in Fig. 1.

It will be appreciated that likewise, in the top of each of the projections 104 there could be provided a dowel-hole-shaped recess, dimensioned and situated so as to receive a further locking stud on the top of each of the projections 5 on the packaging element 1 shown in Fig. 1.

In Fig. 3, there is shown a box-shaped article G embraced by two packaging elements 1 and two packaging elements 101, the latter being placed along the lower side edges of the article G in such a manner, that the latter's bottom surface rests on the supporting surfaces 103 on the packaging elements 101, while the packaging elements 1 are placed along the upper end edges of the article G with the supporting surfaces 3 abutting against the top surface of the article G. It will be appreciated that in the packaging elements 101, the longer side of the rectangular supporting surface 103 corresponds to the length of one of the side edges of the article G, while the longer side of the rectangular supporting surface 3 on each of the packaging elements 1 corresponds to the length of one of the end edges of the article G.

In the situation shown, the locking studs 7 and 8 at each end of the packaging element 1 are in engagement with the locking recesses or locking holes 107 and 108 facing them
5 in each of the packaging elements 101.

With the packaging element 1 and 101 placed on the article G as shown in Fig. 3, it will be easy to place the article and the packaging elements in an external packaging ele-
10 ment, such as a suitably dimensioned corrugated-paper box.

It will be appreciated that if the packaging elements 1 comprise a further locking stud situated as explained with reference to Fig. 1, and the packaging elements 101 comprise
15 a corresponding further locking recess or hole as explained with reference to Fig. 2, it will also be possible to place the packaging elements 1 and 101 on the box-shaped article G in such a manner, that together they embrace the side surfaces or the end surfaces of the article.

LIST OF PARTS

	G	Box-shaped article
	1	Packaging element
5	2	Base surface
	3	Supporting surface
	4	Projection
	5	Projection
	6	Projection
10	7	Locking stud
	8	Locking stud
	101	Packaging element
	102	Base surface
	103	Supporting surface
15	104	Projection
	105	Projection
	106	Projection
	107	Locking recess
	108	Locking recess

CLAIMS.

1. Packaging element (1,101) in the form of a shell
of pulp material for supporting an end part and/or side
part of a preferably box-shaped article (G) being packaged
5 in a shipping package, said packaging element (1,101) comprising a supporting surface (3, 103) spaced from a basis surface (2,102) as well as a number of projections (4,5,6, 104, 105, 106) projecting beyond the level of said supporting
10 surface for partially embracing the end part and/or side part of said article (G), characterized in that the packaging element (1,101) is symmetrical about a transverse plane at right angles through the center of the rectangular base surface (2, 102) and asymmetrical about a longitudinal plane
15 at right angles through the center of the base surface (2, 102), said element (1, 101) at each end of the mainly rectangular supporting surface (3, 103) comprising two projections (4, 5, 104, 105) protruding to the same height above
20 said supporting surface, viz. a first projection (4, 104) extending along the shorter side of the supporting surface (3, 103) and a second projection (5, 105) extending along the first projection (4, 104) and the longer side of the supporting surface (3, 103).

25 2. Packaging element (1, 101) according to claim 1, characterized in that it is adapted, by means of locking members (7,8, 107, 108) associated with the projections (4, 5, 104, 105) to engage in a securing manner with complementary locking members (107, 108, 7, 8) on or in another,
30 similar packaging element (101, 1).

3. Packaging element (1) according to claim 2, characterized in that each of the two projections (4, 5) at each end of the supporting surface (3) comprises at least

one projection protruding upwardly from its upper surface in the shape of a locking stud (7,8).

5 4. Packaging element (101) according to claim 2,
characterized in that at least the projection (105) extending
along the longer side of the supporting surface (103) com-
prises recesses extending from its upper surface in the
form of dowel-holes (107, 108), dimensioned and situated
in such a manner, that each of them can receive a projection
10 in the form of a locking stud (7, 8) on another, similar
packaging element (1).

AMENDED CLAIMS

[received by the International Bureau on 5th September 1994 (05.09.94); original claim 1 amended; remaining claims unchanged (1 page)]

1. Packaging element (1,101) in the form of a shell
of pulp material for supporting an end part and/or side
5 part of a preferably box-shaped article (G) being packaged
in a shipping package, said packaging element (1,101) com-
prising a supporting surface (3, 103) spaced from a basis
surface (2,102) as well as a number of projections (4,5,6,
10 104, 105, 106) projecting beyond the level of said supporting
surface for partially embracing the end part and/or side
part of said article (G), and in which the packaging element
(1,101) is symmetrical about a transverse plane at right
angles through the center of the rectangular base surface
(2, 102) and asymmetrical about a longitudinal plane at
15 right angles through the center of the base surface (2,
102), characterized in, that said element (1, 101) at each
end of the mainly rectangular supporting surface (3, 103)
comprises two separate projections (4, 5, 104, 105)
protruding to the same height above said supporting surface,
20 viz. a first projection (4, 104) extending along the shorter
side of the supporting surface (3, 103) and a second
projection (5, 105) extending along the first projection
(4, 104) and a part of the longer side of the supporting
surface (3, 103), and that said element (1, 101) is
25 dimensioned for use as one of a pair of such elements
cooperating with a corresponding packaging element with
their supporting surfaces (3, 103) embracing the article
(G) and facing each other, and with the top surfaces of
said projections (4, 104, 5, 105) closely facing against each
30 other.

2. Packaging element (1, 101) according to claim 1,
characterized in that it is adapted, by means of locking
members (7,8, 107, 108) associated with the projections (4,
35 5, 104, 105) to engage in a securing manner with complemen-
tary locking members (107, 108, 7, 8) on or in another,

3. Packaging element (1) according to claim 2, characterized in that each of the two projections (4, 5) at each end of the supporting surface (3) comprises at least one projection protruding upwardly from its upper surface
5 in the shape of a locking stud (7,8).

4. Packaging element (101) according to claim 2, characterized in that at least the projection (105) extending along the longer side of the supporting surface (103) comprises recesses extending from its upper surface in the
10 form of dowel-holes (107, 108), dimensioned and situated in such a manner, that each of them can receive a projection in the form of a locking stud (7, 8) on another, similar packaging element (1).

STATEMENT UNDER ARTICLE 19

In new claim 1, the symmetrical-asymmetrical formation of the packaging element (1, 101), vide the first five lines of the characterizing clause in the originally filed claim 1, is now part of the preamble of claim 1. Moreover, the projections (4-104, 5-105) have been more clearly defined in conformity with the description and the drawings as filed.

Thus defining the invention more clearly in view of what appears especially from both cited documents Category "Y". None of these citations concern packaging elements which are adapted to be placed transversely of each other, as explained in the first paragraph on page 2 of the description.

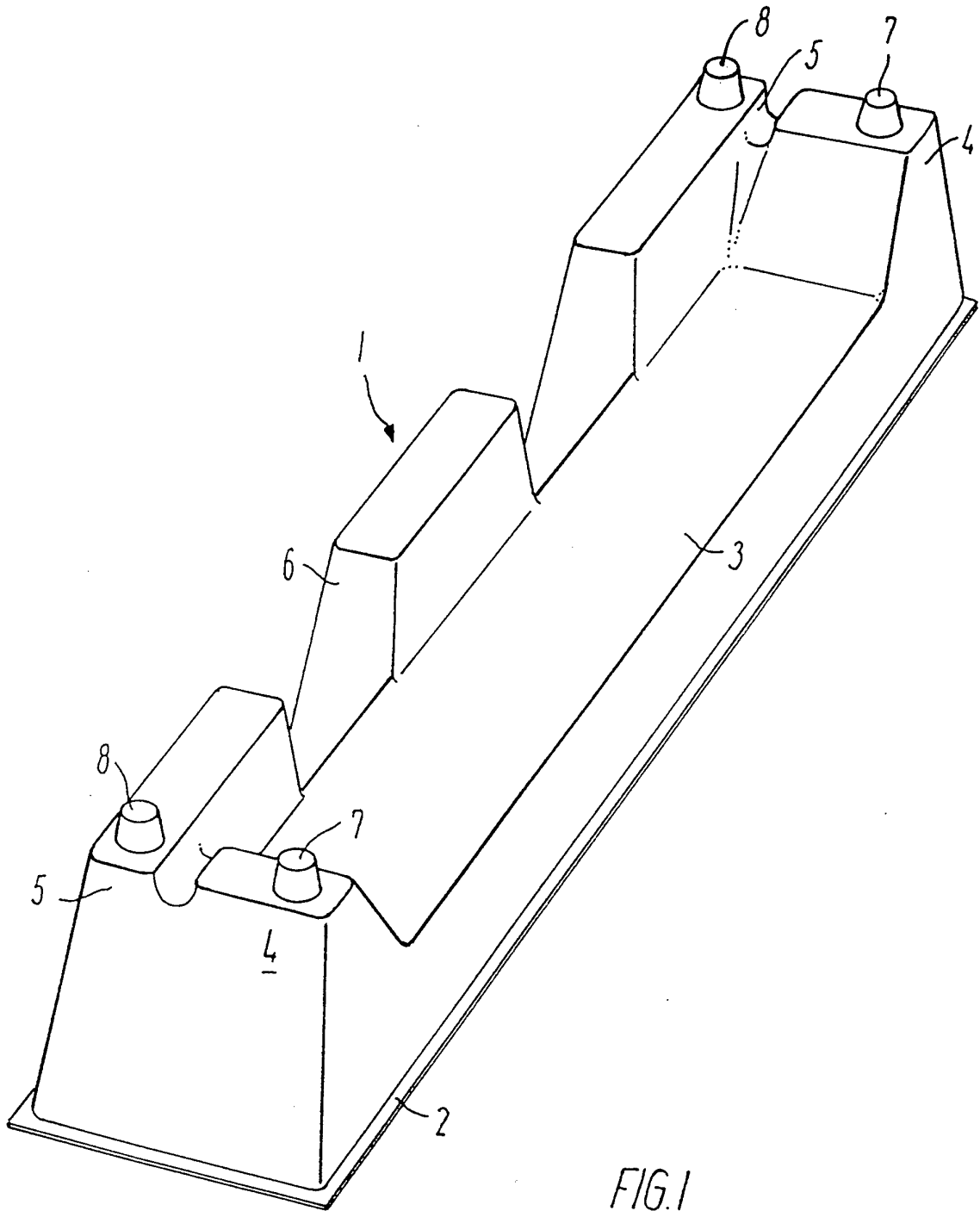

FIG. 1

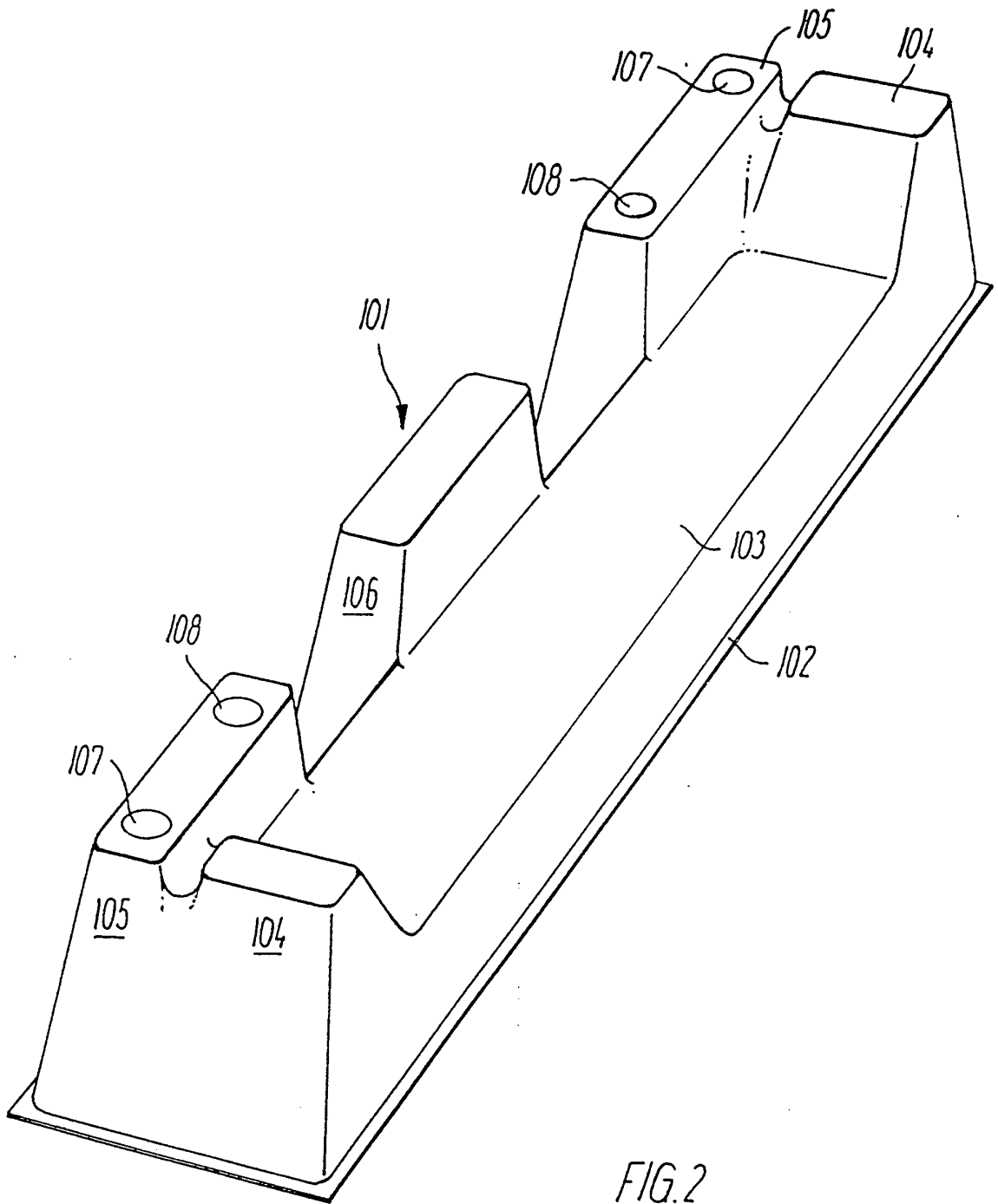

FIG. 2

3/3

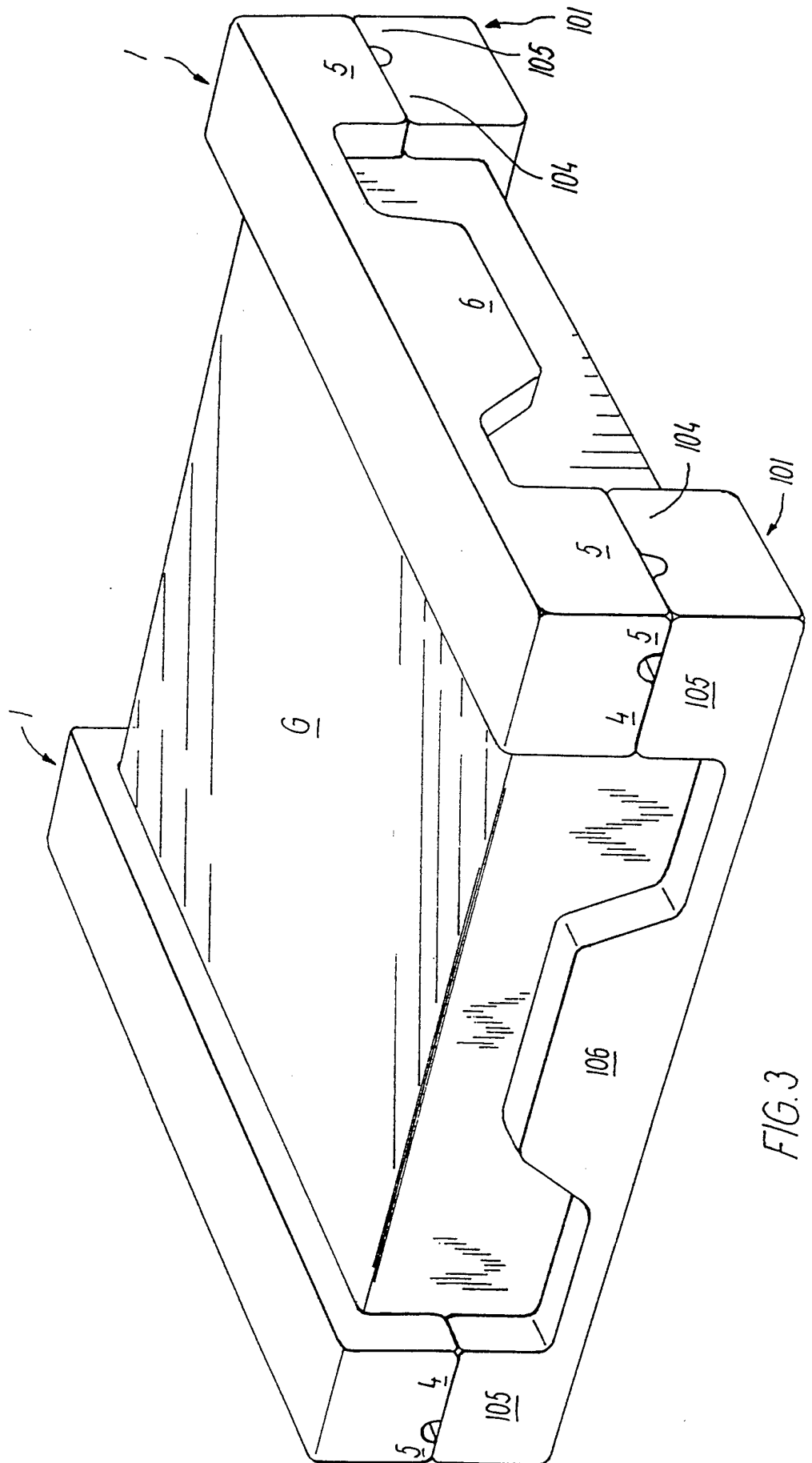

FIG. 3

INTERNATIONAL SEARCH REPORT

International application No.

PCT/DK 93/00309

A. CLASSIFICATION OF SUBJECT MATTER		
IPC5: B65D 81/16 According to International Patent Classification (IPC) or to both national classification and IPC		
B. FIELDS SEARCHED		
Minimum documentation searched (classification system followed by classification symbols)		
IPC5: B65D		
Documentation searched other than minimum documentation to the extent that such documents are included in the fields searched		
SE,DK,FI,NO classes as above		
Electronic data base consulted during the international search (name of data base and, where practicable, search terms used)		
C. DOCUMENTS CONSIDERED TO BE RELEVANT		
Category*	Citation of document, with indication, where appropriate, of the relevant passages	Relevant to claim No.
Y	Patent Abstracts of Japan, Vol 13, No 311, M-851, abstract of JP, A, 1-99982 (TOKYO CONTAINER KOGYO K.K.), 18 April 1989 (18.04.89) --	1-4
Y	US, A, 4173286 (STANKO), 6 November 1979 (06.11.79), column 1, line 1 - column 2, line 2, figure 2, abstract --	1-4
A	DE, A1, 2326019 (SONY CORP.), 6 December 1973 (06.12.73), page 1, line 1 - page 3, line 31, figure 19 --	1-4
<input checked="" type="checkbox"/> Further documents are listed in the continuation of Box C. <input checked="" type="checkbox"/> See patent family annex.		
<p>* Special categories of cited documents:</p> <p>"A" document defining the general state of the art which is not considered to be of particular relevance</p> <p>"E" earlier document but published on or after the international filing date</p> <p>"L" document which may throw doubts on priority claim(s) or which is cited to establish the publication date of another citation or other special reason (as specified)</p> <p>"O" document referring to an oral disclosure, use, exhibition or other means</p> <p>"P" document published prior to the international filing date but later than the priority date claimed</p> <p>"T" later document published after the international filing date or priority date and not in conflict with the application but cited to understand the principle or theory underlying the invention</p> <p>"X" document of particular relevance: the claimed invention cannot be considered novel or cannot be considered to involve an inventive step when the document is taken alone</p> <p>"Y" document of particular relevance: the claimed invention cannot be considered to involve an inventive step when the document is combined with one or more other such documents, such combination being obvious to a person skilled in the art</p> <p>"&" document member of the same patent family</p>		
Date of the actual completion of the international search		Date of mailing of the international search report
27 December 1993		29 -12- 1993
Name and mailing address of the ISA/ Swedish Patent Office Box 5055, S-102 42 STOCKHOLM. Facsimile No. +46 8 666 02 86		Authorized officer <i>Helena Skarvland</i> Kerstin Hällgren Telephone No. +46 8 782 25 00

INTERNATIONAL SEARCH REPORT

International application No.

PCT/DK 93/00309

C (Continuation). DOCUMENTS CONSIDERED TO BE RELEVANT		
Category*	Citation of document, with indication, where appropriate, of the relevant passages	Relevant to claim No.
A	DE, A1, 2646908 (BELLAPLAST GMBH), 20 April 1978 (20.04.78), figure 1, claim 1 ----- -----	1-4

INTERNATIONAL SEARCH REPORT
Information on patent family members

27/11/93

International application No.

PCT/DK 93/00309

Patent document cited in search report	Publication date	Patent family member(s)	Publication date
US-A- 4173286	06/11/79	NONE	
DE-A1- 2326019	06/12/73	NONE	
DE-A1- 2646908	20/04/78	NONE	