



(12) **EUROPEAN PATENT APPLICATION**

(88) Date of publication A3:  
**01.07.2009 Bulletin 2009/27**

(51) Int Cl.:  
**B41J 2/14<sup>(2006.01)</sup> B28B 11/04<sup>(2006.01)</sup>**

(43) Date of publication A2:  
**24.09.2008 Bulletin 2008/39**

(21) Application number: **08075107.6**

(22) Date of filing: **11.02.2008**

(84) Designated Contracting States:  
**AT BE BG CH CY CZ DE DK EE ES FI FR GB GR HR HU IE IS IT LI LT LU LV MC MT NL NO PL PT RO SE SI SK TR**  
 Designated Extension States:  
**AL BA MK RS**

(71) Applicant: **Ingegneria Ceramica S.r.l.**  
**41049 Sassuolo (MO) (IT)**

(72) Inventor: **Guidotti, Gian Mario**  
**41100 Modena (IT)**

(74) Representative: **Gotra, Stefano**  
**BUGNION S.p.A.**  
**Via M. Vellani, 20**  
**41124 Modena (IT)**

(30) Priority: **20.03.2007 IT MO20070098**

(54) **A printing head for tile decoration**

(57) The invention relates to a printing head (1) for decorating tiles (11), comprising at least a hollow element (2), internally of which a conduit (3) is afforded, destined to contain pressurised glaze (4). The conduit (3) exhibits at least an outlet nozzle (6) for the glaze (4). An obturator

(9) is associated to each nozzle (6) and is mobile between a closed position of the nozzle (6) and an open position of the nozzle (6). The obturator (9) is activated by a relative piezo-electric actuator (10), arranged internally of the conduit (3), to which it is solidly constrained.

**FIG 1**

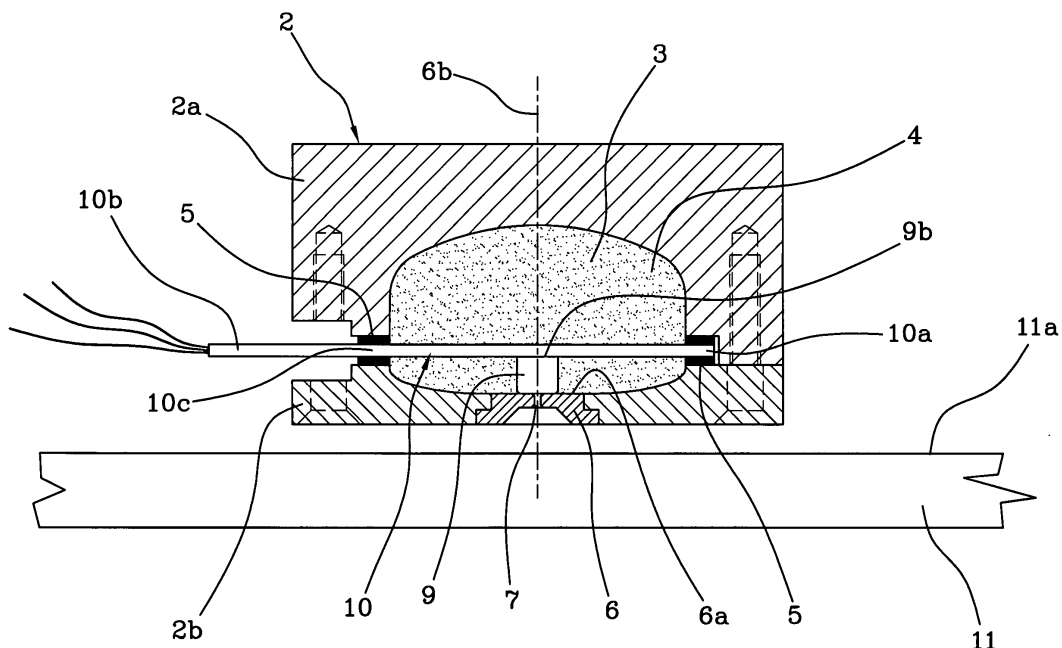



EUROPEAN SEARCH REPORT

Application Number  
EP 08 07 5107

DOCUMENTS CONSIDERED TO BE RELEVANT			
Category	Citation of document with indication, where appropriate, of relevant passages	Relevant to claim	CLASSIFICATION OF THE APPLICATION (IPC)
X	DE 196 26 428 A1 (HEINZL JOACHIM [DE]; EDERER INGO [DE]; TILLE CARSTEN [DE]) 15 January 1998 (1998-01-15)	1-4,9	INV. B41J2/14 B28B11/04
Y	* abstract * * figures 1,2,17 * * column 1, line 6 - line 8 * * column 7, line 4 - line 8 * * column 9, line 41 - line 65 * * column 10, line 20 - line 30 * * column 11, line 16 - line 18 * * column 11, line 21 - line 26 * -----	8	
X	EP 1 036 660 A (TALLY GMBH [DE] TALLY COMPUTERDRUCKER GMBH [DE]) 20 September 2000 (2000-09-20) * figures 1,3,9,10b * * claim 1 * * paragraph [0055] * -----	1-3,5-7,9	TECHNICAL FIELDS SEARCHED (IPC)  B41J B28B
X	EP 1 652 672 A (SAMSUNG ELECTRONICS CO LTD [KR]) 3 May 2006 (2006-05-03) * figures 3,5,7,8a,8b * * paragraph [0031] - paragraph [0032] * * paragraph [0043] * * paragraph [0045] * * paragraph [0057] - paragraph [0060] * -----	1-3,9	
X	WO 86/05722 A (LANE INT LTD JOHN [GB]) 9 October 1986 (1986-10-09) * abstract; figures 1,2 * * page 3, line 10 - line 20 * * page 4, line 35 - page 5, line 7 * * page 6, line 17 - line 20 * ----- -/--	1,5,7,9	
3 The present search report has been drawn up for all claims			
Place of search The Hague		Date of completion of the search 25 May 2009	Examiner João, César
CATEGORY OF CITED DOCUMENTS X : particularly relevant if taken alone Y : particularly relevant if combined with another document of the same category A : technological background O : non-written disclosure P : intermediate document		T : theory or principle underlying the invention E : earlier patent document, but published on, or after the filing date D : document cited in the application L : document cited for other reasons ..... & : member of the same patent family, corresponding document	

EPO FORM 1503 03.82 (P04C01)



EUROPEAN SEARCH REPORT

Application Number  
EP 08 07 5107

DOCUMENTS CONSIDERED TO BE RELEVANT			
Category	Citation of document with indication, where appropriate, of relevant passages	Relevant to claim	CLASSIFICATION OF THE APPLICATION (IPC)
Y	US 2005/001881 A1 (NAKASHIMA HIROAKI [JP] ET AL) 6 January 2005 (2005-01-06) * paragraph [0128] - paragraph [0130]; figures 13,14 * -----	8	
A	WO 01/51573 A (FERRO CORP [US]) 19 July 2001 (2001-07-19) * the whole document * -----	1-9	
A	EP 1 334 811 A (SYSTEM SPA [IT]) 13 August 2003 (2003-08-13) * the whole document * -----	1-9	
			TECHNICAL FIELDS SEARCHED (IPC)
The present search report has been drawn up for all claims			
Place of search The Hague		Date of completion of the search 25 May 2009	Examiner João, César
CATEGORY OF CITED DOCUMENTS X : particularly relevant if taken alone Y : particularly relevant if combined with another document of the same category A : technological background O : non-written disclosure P : intermediate document		T : theory or principle underlying the invention E : earlier patent document, but published on, or after the filing date D : document cited in the application L : document cited for other reasons ..... & : member of the same patent family, corresponding document	

3  
EPO FORM 1503 03.82 (P4/C01)

ANNEX TO THE EUROPEAN SEARCH REPORT  
ON EUROPEAN PATENT APPLICATION NO.

EP 08 07 5107

This annex lists the patent family members relating to the patent documents cited in the above-mentioned European search report. The members are as contained in the European Patent Office EDP file on  
The European Patent Office is in no way liable for these particulars which are merely given for the purpose of information.

25-05-2009

Patent document cited in search report	Publication date	Patent family member(s)	Publication date
DE 19626428 A1	15-01-1998	CA 2259311 A1	08-01-1998
		WO 9800237 A1	08-01-1998
		EP 0907421 A1	14-04-1999
		US 6116517 A	12-09-2000
EP 1036660 A	20-09-2000	CN 1266783 A	20-09-2000
		DE 19911399 A1	28-09-2000
		JP 2000296619 A	24-10-2000
		US 6460979 B1	08-10-2002
EP 1652672 A	03-05-2006	JP 2006130917 A	25-05-2006
		KR 20060039111 A	08-05-2006
		US 2006092237 A1	04-05-2006
WO 8605722 A	09-10-1986	EP 0215884 A1	01-04-1987
		ES 8703299 A1	01-05-1987
		FI 864770 A	24-11-1986
		JP 63500156 T	21-01-1988
US 2005001881 A1	06-01-2005	DE 112004000028 T5	20-04-2006
		EP 1617999 A1	25-01-2006
		WO 2004096553 A1	11-11-2004
		WO 2004096554 A1	11-11-2004
		US 2005001868 A1	06-01-2005
WO 0151573 A	19-07-2001	AU 2074901 A	24-07-2001
		CN 1420916 A	28-05-2003
		DE 60018617 D1	14-04-2005
		DE 60018617 T2	01-09-2005
		EP 1272574 A1	08-01-2003
		ES 2238332 T3	01-09-2005
		US 6402823 B1	11-06-2002
		IT M020020026 A1	07-08-2003

EPO FORM P0459

For more details about this annex : see Official Journal of the European Patent Office, No. 12/82