

**(12) PATENT**  
**(19) AUSTRALIAN PATENT OFFICE**

**(11) Application No. AU 200072525 B2**  
**(10) Patent No. 762272**

(54) Title  
Composite masonry block

(51)<sup>6</sup> International Patent Classification(s)  
E02D 029/02

(21) Application No: 200072525 (22) Application Date: 2000 . 12 . 22

(43) Publication Date : 2001 . 04 . 05  
(43) Publication Journal Date : 2001 . 04 . 05  
(44) Accepted Journal Date : 2003 . 06 . 19

(62) Divisional of:  
199869878

(71) Applicant(s)  
Anchor Wall Systems, Inc; Dick J Sievert; Michael E Woolford

(72) Inventor(s)  
Dick J Sievert; Michael E Woolford

(74) Agent/Attorney  
GRIFFITH HACK,GPO Box 1285K,MELBOURNE VIC 3001

(56) Related Art  
GB 107338  
WO 98/02050

ABSTRACT

A masonry block is disclosed. The block has a front surface (12), a back surface (18), a top surface (10) and bottom surface (8), and first and second sides (14, 16).  
5 The first side (14) has a first locator wall (22A) which extends from the block top surface to the block bottom surface, and the second side (16) has a second locator wall (22B) which extends from the block top surface to the block  
10 bottom surface. The block also has a protrusion (26) configured on the top or bottom surface to mate with a locator wall of one or more blocks in an adjacent course. The protrusion (26) and the locator walls (22A, 22B) have relative sizes and shapes adapted to permit relative  
15 rotation of the blocks to enable some play between the protrusion (26) and the locator wall (22A, 22B) with which it is mated whereby serpentine walls may be constructed from a plurality of courses of such blocks.

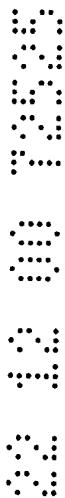

AUSTRALIA  
Patents Act 1990

**COMPLETE SPECIFICATION**  
**STANDARD PATENT**

**Applicant(s):**

ANCHOR WALL SYSTEMS, INC

and

DICK J SIEVERT

and

MICHAEL E WOOLFORD

**Invention Title:**

COMPOSITE MASONRY BLOCK



The following statement is a full description of this invention, including the best method of performing it known to me/us:

---

COMPOSITE MASONRY BLOCK

Field of the Invention

5           The invention generally relates to concrete masonry blocks. More specifically, the invention relates to concrete masonry blocks which are useful in forming various retaining structures.

10           The invention has been divided from Australian application 69878/98 for a standard patent and the disclosure in the patent specification of that patent application is incorporated herein by cross-reference.

15           Background of the invention

          Soil retention, protection of natural and artificial structures, and increased land use are only a few reasons which motivate the use of landscape structures.  
20 For example, soil is often preserved on a hillside by maintaining the foliage across that plain. Root systems from the trees, shrubs, grass, and other naturally occurring plant life, work to hold the soil in place against the forces of wind and water. However, when  
25 reliance on natural mechanisms is not possible or practical, man often resorts to the use of artificial mechanisms such as retaining walls.



          In constructing retaining walls, many different  
30 materials may be used depending on the given application. If a retaining wall is intended to be used to support the construction of a roadway, a steel wall or a concrete and steel wall may be appropriate. However, if the retaining wall is intended to landscape and conserve soil around a  
35 residential or commercial structure, a material may be used which compliments the architectural style of the structure such as wood timbers or concrete block.



Of all these materials, concrete block has received wide and popular acceptance for use in the construction of retaining walls and the like. Blocks used for these purposes include those disclosed by Forsverg,  
5 U.S. Patent No. 4,802,320 and Design 296,007, among others.

Previously, blocks have been designed to "setback" at an angle to counter the pressure of the soil behind the wall. Setback is generally considered the  
10 distance in which one course of a wall extends beyond the front



surface of the next highest course of the same wall. Given blocks of the same proportion, setback may also be regarded as the distance which the back surface of a higher course of blocks extends backwards in relation to the back surface of a lower course of the wall.

There is often a need in the development of structures such as roadways, abutments and bridges to provide maximum usable land and a clear definition of property lines. Such definition is often not possible through use of a composite masonry block which results in a setback wall. For example, a wall which sets back by its very nature will cross a property line and may also preclude maximization of usable land in the upper or subjacent property. As a result, a substantially vertical wall is more appropriate and desirable.

However, in such instances, vertical walls may be generally held in place through the use of well known mechanisms such as pins, deadheads, tie backs or other anchoring mechanisms to maintain the vertical profile of the wall. Besides being complex, anchoring mechanisms such as pin systems often rely on only one strand or section of support tether which, if broken, may completely compromise the structural integrity of the wall. Reliance on such complex fixtures often discourages the use of retaining wall systems by the everyday homeowner. Commercial landscapers may also avoid complex retaining wall systems as the time and expense involved in constructing these systems is not supportable given the price at which landscaping services are sold.

Further, retaining structures are often considered desirable in areas which require vertical wall but are not susceptible to any number of anchoring matrices or mechanisms. For example, in the construction of a retaining wall adjacent a building or other structure, it may not be possible to provide anchoring mechanisms such as a matrix web, deadheads or tie backs far enough



into the retained earth to actually support the wall. Without a retaining mechanism such as a matrix web, tie-back, or dead head, many blocks may not offer the high mass per face square foot necessary for use in retaining structures which have substantially vertical profile.

Manufacturing processes may also present impediments to structures of adequate integrity and strength. Providing blocks which do not require elaborate pin systems or other secondary retaining and aligning means and are still suitable for constructing structures of optimal strength is often difficult. Two examples of block molding systems are disclosed in commonly assigned Woolford et al, U.S. Patent No. 5,062,610 and Woolford, U.S. Patent Application Serial No. 07/828,031 filed January 30, 1992 which are incorporated herein by reference. In both systems, advanced design and engineering is used to provide blocks of optimal strength and, in turn, structures of optimal strength, without the requirement of other secondary systems such as pins and the like. The Woolford et al patent discloses a mold which, through varying fill capacities provides for the uniform application of pressure across the fill. The Woolford application discloses a means of forming block features through the application of heat to various portions of the fill.

As can be seen there is a need for a composite masonry block which is stackable to form walls of high structural integrity without the use of complex pin and connection systems and without the need for securing mechanisms such as pins, or tie backs.

According to the present invention there is provided a masonry block, comprising a front surface, back surface, a top surface and bottom surface, and first and second sides, said first side having a first locator wall wherein said first locator wall extends from said block top

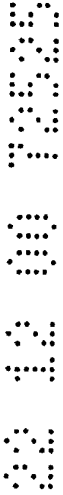

surface to said block bottom surface, said second side  
having a second locator wall wherein said second locator  
wall extends from said block top surface to said block  
bottom surface, said block comprising a protrusion  
5 configures on said top or bottom surface to mate with a  
locator wall of one or more blocks in an adjacent course,  
said protrusion and said locator walls having relative  
sizes and shapes adapted to permit relative rotation of  
said blocks to enable some play between the protrusion and  
10 the locator wall with which it is mated whereby serpentine  
walls may be constructed from a plurality of courses of  
such blocks.

According to the present invention there is  
15 provided a retaining wall structure comprising at least an  
upper and an adjacent lower course, each of the upper and  
lower course comprising one or more blocks of the present  
invention.

20 Brief Description of the Drawings

FIGURE 1 is a perspective view of one preferred  
embodiment of the block in accordance with the invention.



25 FIGURE 2 is a side plan view of the block of Fig.  
1.

FIGURE 3 is a top plan view of the block of Fig.  
1.



30 FIGURE 4 is a perspective view of an alternative  
preferred embodiment of the block in accordance with the  
invention.



35 FIGURE 5 is a side plan view of the block of Fig.  
4.





FIGURE 6 is a top plan view of the block of Fig. 4.

FIGURE 7 is a perspective view of a retaining structure constructed with one embodiment of the composite masonry block of the invention.

FIGURE 8 is a cut away view of the wall shown in Fig. 7 showing a vertical wall taken along lines 8-8.

FIGURE 9 is a perspective view of a further alternative embodiment of the block in accordance with the invention.

FIGURE 10 is a perspective view of another further alternative embodiment of the block in accordance with the invention.

FIGURE 11 is a top plan view of the block depicted in Fig. 10.



FIGURE 12 is a cutaway view of a retaining structure constructed with the blocks depicted in Figs. 9 and 10.

FIGURE 13 is a top plan view of a block in accordance with a preferred alternative aspect of the invention.

FIGURE 14 is a top plan view of a block in accordance with a further preferred alternative aspect of the invention.

FIGURE 15 is a side plan view of the block shown in Figure 13.

FIGURE 16 is an enlarged side plan view of the block depicted in Figure 15 showing, in detail, aspects of protrusion 26.

FIGURE 17A is an exploded perspective view of the stripper shoe and head assembly of the invention.

FIGURE 17B is perspective view of the mold assembly of the invention.

FIGURE 18 is a schematic depiction of the molding process of the invention.

Detailed Description of the Preferred Embodiments

Turning to the figures wherein like parts are designated with like numerals throughout several views, there is shown a composite masonry block in Figure 1.

The block generally comprises a front surface 12 and a back surface 18 adjoined by first and second side surfaces 14 and 16, respectively, as well as a top surface 10 and a bottom surface 8 each lying adjacent said front 12, back 18, and first 14 and second 16 side surfaces. Each of said side surfaces has an inset, 22A and 22B, spanning from the block top surface 10 to the block bottom surface 8. The block top surface 10 may also comprise one or more protrusions 26. Each protrusion is preferably positioned adjacent an inset 22A or 22B, on the block top surface 10.

The block back surface 18 generally comprises first and second legs 24A and 24B, respectively. The first



leg 24A extends from the back surface 18 beyond the plane of the block first side 14. The second leg 24B extends from the back surface 18 beyond the plane of the block second side 16.

5 Composite Masonry Block

The composite masonry block of the invention generally comprises a block body. The block body 5 functions to retain earth without the use of secondary mechanisms such as pins, dead heads, webs and the like. 10 Preferably, the block body provides a retaining structure which may be manually positioned by laborers while also providing a high relative mass per square foot of face or front surface presented in the wall. To this end, the block may generally comprise a six-surface 15 article.

The most apparent surface of the block is generally the front surface 12 which functions to provide an ornamental or decorative look to the retaining structure, Figs. 1-3. The front surface of the block 20 may be flat, rough, split, convex, concave, or radial. Any number of designs may be introduced into the front surface. Two preferred front surfaces may be seen in Figs. 1-3 and 4-6. Additionally, two alternative 25 embodiments of the block of the invention may be seen in Figs. 9-11. The block of the invention may comprise a flat or planar front surface or a roughened front surface 12 created by splitting a portion of material from the front of the block, Fig. 1-3. In accordance with one other embodiment of the invention, 30 the block may comprise a split or faceted front surface having three sides, Figs. 4-6.

The block of the invention generally also comprises two side surfaces 14 and 16, Figs. 1-6. These side surfaces assist in definition of the block shape as well 35 as in the stacked alignment of the block. Generally, the block of the invention may comprise side surfaces which take any number of forms including flat or planar

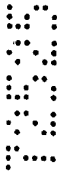

side surfaces, angled side surfaces, or curved side surfaces. The side surfaces may also be notched, grooved, or otherwise patterned to accept any desired means for further aligning or securing the block during placement.

One preferred design for the side surfaces may be seen in Figs. 1-6. As can be seen, the side surfaces 14 and 16 are angled so as to define a block which has a greater width at the front surface 12 than at the back surface 18. Generally, the angle of the side surfaces (See Figs. 3 and 6) in relationship to the back surface as represented by alpha degrees, may range from about 70° to 90°, with an angle of about 75° to 85°, being preferred.

The side surfaces may also comprise insets 22A and 22B for use in receiving other means which secure and align the blocks during placement. In accordance with one embodiment of the invention, the insets may span from the block top surface 10 to the block bottom surface 8. Further, these insets may be angled across the height of the block to provide a structure which gradually sets back over the height of the wall. When mated with protrusions 26, the insets may also be angled to provide a retaining wall which is substantially vertical.

The angle and size of the insets may be varied in accordance with the invention. However, the area of the inset adjacent the block bottom surface 8 should be approximately the same area as, or only slightly larger than, protrusion 26 with which it will mate. The area of the insets adjacent the block top surface 10 is preferably larger than the protrusion 26 by a factor of 5% or more and preferably about 1% to 2% or more. This will allow for adequate movement in the interfitting of blocks in any structure as well as allowing blocks of higher subsequent courses to setback slightly in the retaining structure. Further, by varying the size and

position of the inset relative to protrusion 26, the set  
back of the wall may be varied. Further, by varying the  
position of the protrusion within an inset of greater  
relative size the set back of a retaining structure may  
5 be varied in the structure. For example, by pulling the  
blocks forward as far as possible a setback of about  
1/8" may be attained in the wall. By pushing the blocks  
backward as far as possible, a set back of up to 3/4"  
may be attained. Here again, movement forward and  
10 backward is the movement of protrusion 26 within the  
confines of insets 22A and 22B.

Generally, the top 10 and bottom 8 surfaces of the  
block function similarly to the side surfaces of the  
block. The top 10 and bottom 8 surfaces of the block  
15 serve to define the structure of the block as well as  
assisting in the aligned positioning of the block in any  
given retaining structure. To this end, the top and  
bottom surfaces of the block are generally flat or  
planar surfaces.

20 Preferably, as can be seen in Figs. 1-6, either the  
top or bottom surface comprises a protrusion 26. The  
protrusion functions in concert with the side wall  
insets 22A and 22B to secure the blocks in place when  
positioned in series or together on a retaining  
25 structure by aligning the protrusions 26 within the  
given insets. While the protrusions may take any number  
of shapes, they preferably have a kidney or dogbone  
shape. As can be seen in Figs. 1-6 as well as Figs. 9-  
11, the protrusion may comprise two circular or oblong  
30 sections which are joined across their middle by a  
narrower section of the same height. The central narrow  
portion in the protrusion 26 (Figs. 1-6) allows for  
orientation of the blocks to provide inner curving and  
outer curving walls by the aligned seating and the  
35 relative rotation of the protrusion 26 within, and in  
relationship to, any block inset 22A or 22B. In turn,  
the larger surface area of the dogbone naturally gives

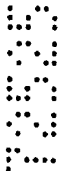

this protrusion greater strength against forces which otherwise could create movement among individual wall blocks or fracture of this element of the block.

Generally, the protrusions may comprise formed nodules or bars having a height ranging from about 3/8 inch to 3/4 inch, and preferably about 1/2 inch to 5/8 inch. The width or diameter of the protrusions may range from about 1 inch to 3 inches, and preferably about 1-1/2 inches to 2-1/2 inches. In shipping, the protrusions may be protected by stacking the blocks in inverted fashion, thereby nesting the protrusions within opening 30.

Generally, the protrusions 26 and insets 22A and 22B may be used with any number of other means which function to assist in securing the retaining wall against fill. Such devices include tie backs, deadheads, as well as web matrices such as GEOGRID™ available from Mirafi Corp. or GEOMET™ available from Amoco.

The back surface 18 of the block generally functions in defining the shape of the block, aligning the block as an element of any retaining structure, as well as retaining earth or fill. To this end, the back surface of the block may take any shape consistent with these functions.

One preferred embodiment of the block back surface can be seen in Figs. 1-6. In accordance with the invention, the back surface may preferably be planar and have surfaces 28A and 28B which extend beyond the side surfaces of the block. In order to make the block more portable and easily handled, the block may be molded with any number of openings including central opening 30. This central opening 30 in the block allows for a reduction of weight during molding. Further, these openings allow for the block to be filled with earth or other product such as stone, gravel, rock, and the like which allows for an increase in the effective mass of



the block per square foot of front surface. Openings may also be formed in the front portion of the blocks as can be seen by openings 34 and 36. Additional fill may be introduced into openings 30, 34, and 36 as well as the openings formed between surfaces 28A and 28B and adjacent side walls 14 and 16, respectively.

In use, a series of blocks are preferably placed adjacent each other, forming a series of fillable cavities. Each block preferably will have a central cavity 30 for filling as well as a second cavity formed between any two adjacently positioned blocks. This second cavity is formed by opposing side walls 14 and 16, and adjacently positioned back surfaces 28A and 28B. This second cavity, formed in the retaining structure by the two adjacent blocks, holds fill and further increases the mass or actual density of any given block structure per square foot of front surface area.

Generally, an unfilled block may weigh from about 115 to 155 pounds, preferably from about 115 to 125 pounds per square foot of front surface. Once filled, the block mass will vary depending upon the fill used but preferably the block may retain a mass of about 160 to 180 pounds, and preferably about 165 to 175 pounds per square foot of front surface when using rock fill such as gravel or class 5 road base.

Two alternative preferred embodiments of the invention can be seen in Figs. 9-11. First, as can be seen in Fig. 9, there is depicted a block having cavities 34 and 36 for accepting fill. Further, this block also has sidewall insets 22A and 22B and a protrusion for complimentary stacking with the blocks shown in Figs. 1-6 or Figs. 10-11. Consistent with the other embodiments of the block disclosed herein, this block allows for finishing walls having base courses of larger heavier blocks with blocks which are smaller, lighter and easier to stack on the higher or highest courses. While not required, the block depicted in



Figs. 1-6 and 10-11 may be larger in dimension than the block of Fig. 9 from the front surface to back surface allowing for the construction of a structure such as that shown in Fig. 12. Further, the use of the dogbone shaped protrusion 26 allows for retention of these blocks in an interlocking fashion with the blocks of lower courses to form a wall of high structural integrity, (see Fig. 12).

The blocks depicted in Fig. 9 may weigh from about 60 to 100 pounds, preferably from about 75 to 95 pounds, and most preferably from about 80 to 90 pounds, with the filled block mass varying from about 90 to 130 pounds, preferably from about 95 to 125 pounds, and most preferably from about 105 to 115 pounds per square foot of front surface using rock fill such as gravel or class 5 road base.

Another alternative embodiment of the block of the invention can be seen in Figs. 10 and 11. As can be seen, the block depicted in Figs. 10 and 11 has angled first and second legs 24A and 24B, respectively, as well as an angled back wall sections, 18, 18A, and 18B.

The resulting back surfaces 28A and 28B, (Fig. 11), have a reduced angle alpha which increases the structural integrity of the wall by increasing the walls resistance to blow out. The angled back surfaces 28A and 28B provide a natural static force which resist the pressure exerted by the angle of repose of fill on any given retaining structure. The angled back surfaces 28A and 28B may be anchored in fill placed between adjacent blocks. Any force attempting to move this block forward, will have to also confront the resistance created by the forward angled back legs moving into adjacently positioned fill or, if the base course, the ground beneath the wall.

The use of angled back walls also facilitates manufacture of the blocks of the invention. Specifically, the angled back sides 28A and 28B assist





in allowing the conveying of blocks once they have been compressed and formed, and they are being transported to the curing facility. Generally, the proximity of the blocks on the conveyer may lead to physical contact. If this contact occurs at a high speed, the blocks may be physically damaged. Also, the use of a conveyer which turns on curves in the course of transporting may naturally lead to contact between blocks and damage. Angling the back side legs 24A and 24B allows easier and more versatile conveyer transport and strengthens the back side legs.

Angling the back sides of the block also assists in the formation of a cell when two blocks are placed adjacent to each other in the same plane. This cell may be used to contain any assortment of fill including gravel, sand, or even concrete. The design of the block of the invention allows the staggered or offset positioning of blocks when building a retaining wall structure. The internal opening 30 of the blocks depicted in Figs. 1-6 and 10-11 may be used in conjunction with the cells created by the adjacent blocks to create a network of channels for the deposition of fill. Specifically, with the offset placement blocks from one course to the next, the opening 30 of a second course block may be placed over a cell created by two blocks positioned adjacent each other in the first course. Thus, opening 30 in second course block is aligned with a cell in the next lower course and this cell may be filled by introducing gravel, sand, etc. into the opening in the second course block. The addition of further courses allows the formation of a series of vertical channels across the retaining structure, (see Fig. 7).

From the axis created by back wall 18 the back legs 24A and 24B may angle towards the front surface of the block ranging from about 5 degrees to 20 degrees, preferably about 7 degrees to 15 degrees, and most

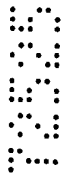

preferably about 10 degrees to twelve degrees. The angle beta may generally range from about 60 to 80 degrees, preferably about 60 to 75 degrees, and most preferably about 65 to 70 degrees. Further, this block  
5 (Figs. 10 and 11) may vary in weight from about 100 to 150 pounds, preferably about 110 to 140 pounds, and most preferably from about 115 to 125 pounds, with the filled block mass varying from about 210 to 265 pounds, preferably from about 220 to 255 pounds, and most  
10 preferably from about 225 to 240 pounds per square foot of front surface using rock fill such as gravel or class 5 road base.

A further preferred embodiment of the invention may be seen in Figures 13-16. We have discovered that when  
15 constructing structures such as those seen in Figures 7 and 8, as well as Figure 12, (for example a retaining wall), several concerns may arise depending upon the dimensions of the block, length and height of the structure, environmental conditions including the nature  
20 of the fill used behind the wall as well as the environment in which the wall is placed including landscape geography, weather, etc. Additionally, depending upon the block manufacturing process used, certain concerns with the dimensions of the block as  
25 well as the various protrusions, openings, and associated block features, may also be raised. Specifically, when constructing the landscape structure such as that shown in Figure 8, the structure is generally assembled one course at a time while the  
30 appropriate fill is placed behind the wall. Once complete, the pressure on the wall will tend to force blocks of each subsequently higher course outward towards the front of the wall. The interlocking nature of the protrusion 26 and insets, 22A and 22B, will  
35 generally resist the movement between the blocks of any two given courses.

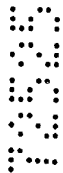

We have found that the structural integrity of a composite masonry block structure generally comes from the coefficient of friction between the blocks of adjacent courses, the footprint of the blocks used in the structure, as well as the nature of the protrusion 26. Generally, the protrusion functions to secure the block on which it is placed or the blocks of the next adjacent course by interfitting with insets 22A and 22B. By using a protrusion having sidewalls of varying angles, the tendency for blocks to push forward out from the wall due to physical stresses is substantially reduced. Further, we have also found that by using a protrusion having sidewalls of varying angles, manufacturing may be streamlined and efficiency increased.

As can be seen in Figures 13 and 14, the composite masonry blocks in accordance with this aspect of the invention are generally similar to those shown in Figures 9-11. These blocks comprise openings 30 and 35 as well as a front face 12 which may be faceted (see Figure 13 at 12A and 12B), or unfaceted (see Figure 14). These blocks provide insets, 22A and 22B, as well as, a protrusion 26 which may span a portion of the upper surface 10 of the block and may boarder the insets 22A and 22B.

Generally, as can be seen in Figures 13 and 14, the protrusion can have four sides. The angle on each of these four sides may vary in accordance with the invention to provide for a more secure placement of blocks as well as ease in processing. Side 26A represented by length A may generally be found adjacent opening 35. Protrusion side 26B spanning length B may generally be found adjacent opening 30. In turn, sides 26C generally span length C may be found adjacent insets 22A and 22B.

With the understanding that the block of the invention may be used in any number of structural

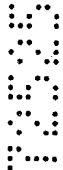

configurations, an additional view of the protrusion of the invention may be seen in Figure 15 in accordance with a preferred aspect of the invention. As can be seen, protrusion 26 generally has visible three  
5 sidewalls, 26A and 26B which are adjoined by 26C, in this view. In this instance, protrusion 26 sidewall 26B is a position towards the block back 18 and is angled so as to provide an adequate stopping or nesting mechanism to prevent any block, placed immediately adjacent it,  
10 from moving forward when stacked in an interlocking form, i.e. by interlocking the protrusion of one block with the insets of an immediately adjacent second block.

Further, by changing the incline of protrusion surface 26A so as to lessen the angle between the upper  
15 surface 10 of the block and protrusion surface 26A (or away from vertical), the protrusion may be formed more easily during block molding. Reducing the angle of surface 26A from vertical allows the application and release of the heated stripper shoe in a manner which  
20 lowers the potential for retaining fill within the heated stripper shoe indentation, (see Figure 17A at 79). Here again, the positioning of protrusion surfaces 26A and 26B may depend upon how the block is to be used, with protrusion surface 26B positioned to resist the  
25 forward movement of subsequent courses of blocks and surface 26A positioned to facilitate manufacture of the block but not compromise the structural integrity of, for example, the resulting wall.

The protrusion 26 preferably may also span the  
30 portion of the topside 10 of the block between inset 22A and 22B. In this instance, protrusion walls 26C run a distance C as can be seen in Figures 13 and 14. Here again, protrusion 26 sidewalls 26C may comprise any angle in relationship to vertical which benefits ease of  
35 manufacture and the structural integrity of any structure made from the block of the invention.

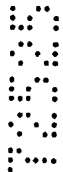

Extending the protrusion 26 across the top side 10 of a portion of the block also benefits manufacture. Generally, in the molding of the block of the invention, the mold will be filled with composite mix to the  
5 intended volume. The heated stripper shoe will then descend upon the fill, compressing the fill, and forming the block of the invention. At the same time, the heated stripper shoe will form protrusion 26 through complementary patterning in indentation 79 in the  
10 underside of the heated stripper shoe (see Figure 17A) to form protrusion 26.

By extending the protrusion 26 from inset 22A through inset 22B an opening is created on either side of the shoe, at the heated stripper shoe outer edge  
15 which spans the width of the shoe. When fill is incidentally retained within the indentation 79 used to form the protrusion 26, it may be effectively removed by automated means such as a brush, scraper, and the like. The exposure of the indentation 79 to the outer edge of  
20 the heated stripper shoe allows a brush to be run across the undersurface of the heated stripper shoe plate to dislodge any fill which has inadvertently found placement in this area.

In accordance with a more preferred mode of the  
25 invention, Figure 16 shows an enlarged cross-sectional view of protrusion 26. As can be seen in Figure 16, protrusion surface 26B generally has an angle delta in relationship to vertical as shown by axis x-x'. In order to provide the greatest resistance towards  
30 displacement of a block on an adjacent course, angle delta generally ranges from about 0-10 degrees from vertical, preferably about 2-7 degrees from vertical, and most preferably about 5 degrees from vertical.

Further, in order to ease manufacture, protrusion  
35 surface 26A will generally have an angle theta which allows ease of manufacture which prevents fill from adhering from the underside of the heated stripper shoe.

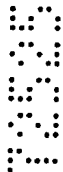

Generally, angle theta may range from 10 to 25 degrees from vertical, preferably from about 15 to 22 degrees from vertical, and preferably about 20 degrees from vertical as represented by access z-z', Figure 16.

5 Here again, as one of skill in the art will realize from reading this application, the orientation of protrusion surfaces 26A and 26B may vary depending upon the structure of the block in the manner in which the block is used in, in overall landscape structure.

10 Generally, surface 26B will preferably be used in order to retain blocks of adjacent courses in place and against forward movement resulting from the physical pressure created by fill loaded behind the structure. Further, protrusion surface 26A will generally be

15 positioned in a non-retaining area of the protrusion so as to facilitate ease and manufacture. As noted earlier, protrusion surface 26C may range in angle from vertical to those limitations put forth for protrusion surface 26A. Generally, the angle of protrusion surface

20 26C should be adjusted to maintain the structural integrity of the block, provide the maximum resistive forces to blocks of adjoining courses, and provide ease in manufacturing.

In use, protrusion 26 may span from inset 22A to

25 inset 22B across a portion of the top surface of the block. Generally, and according to this aspect of the invention, as shown in Figs. 13-16 the protrusion will have a height ranging from one-quarter inch to three-quarter inches and preferably from about three-eighth

30 inches to one-half inches. The overall width of the protrusion from surface 26A to 26B will generally range from about 1 inch to 4 inches, preferably about 2 to 3 inches, and most preferably about 2 1/2 inches between protrusion surface 26A and 26B. Here again, one of

35 skill in the art will understand, having read this specification, how these ranges may be changed or

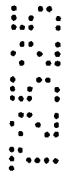

otherwise altered, but still within the scope of the invention.

While all of the blocks depicted herein may be made in varying scales, the following table provides general guidelines on size.

TABLE 1

	<u>BLOCKS OF FIGS. 1-6</u>	<u>General</u>	<u>Preferred</u>	<u>Most Preferred</u>
10				
	front to back	12-30"	15-28"	20-25"
	top to bottom	4-12"	5-10"	6-10"
	side to side*	12-30"	15-25"	15-20"
15				
	<u>BLOCK OF FIG. 9</u>			
20				
	front to back	6-24"	8-15"	10-12"
	top to bottom	4-12"	5-10"	6-10"
	side to side*	12-30"	15-25"	15-20"
25				
	<u>BLOCK OF FIGS. 10-11 and 13-16</u>			
30				
	front to back	12-30"	15-28"	20-25"
	top to bottom	4-12"	5-10"	6-10"
	side to side*	12-30"	15-25"	15-20"

\* block at its greatest dimension on an axis perpendicular to front surface.

Block Structures

The composite masonry block 5 of the invention may be used to build any number of landscape structures.

Examples of the structures which may be constructed with the block of the present invention are seen in Figs. 7-8. As can be seen in Fig. 7, the composite masonry block of the invention may be used to build a retaining wall 10 using individual courses or rows of blocks to construct a wall to any desired height.

Generally, construction of a structure such as a retaining wall 10 may be undertaken by first defining a

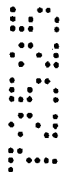

trench area beneath the plane of the ground in which to deposit the first course of blocks. Once defined, the trench is partially refilled and tamped or flattened. The first course of blocks is then laid into the trench.

5 Successive courses of blocks are then stacked on top of preceding courses while backfilling the wall with soil.

The blocks of the present invention also allow for the production of serpentine walls. The blocks may be placed at an angle in relationship to one another so as to provide a serpentine pattern having convex and concave surfaces. If the desired structure is to be inwardly curving, blocks of the invention may be positioned adjacent each other by reducing either surface 28A or 28B on one or both blocks. Such a reduction may be completed by striking leg 24A or 24B with a chisel adjacent deflection 19, see Figs. 1 and 4. Deflection 19 is preferably positioned on the block back surface 18 to allow reduction of the appropriate back surface leg (24A or 24B) while retaining enough potential open area for filling between blocks.

Structures made from composite masonry blocks are disclosed in commonly assigned U.S. Patent No. 5,062,610 which is incorporated herein by reference.

While designed for use without supporting devices, a supporting matrix may be used to anchor the blocks in the earth fill behind the wall. One advantage of the block of the invention is that despite the absence of pins, the distortion created by the block protrusions 26 when mated with insets 22A or 22B anchors the matrix when pressed between two adjacent blocks of different courses.

Further, the complementary design of the blocks of the invention allow the use of blocks 40 such as those depicted in Figs. 1-6 and 10-11 with blocks 42 which are shorter in length in the construction retaining wall structures, (Fig. 12). Tie-backs, deadheads, and web matrices may all be used to secure the retaining wall





structure 46 in place. The generally large pound per square-foot front area of the blocks depicted herein allows blocks such as those depicted in Figs. 1-6 and 10-11 to be used in the base courses with blocks such as those depicted in Fig. 9 used in the upper courses. In turn, the design of all the blocks disclosed herein allows the use retaining means such as geometric matrices (i.e., webs), deadheads and tie backs without pins. Such securing means may be useful in anchoring the smaller blocks in place when used, for example, towards the upper portion of the retaining structure.

The Stripper Shoe/Mold Assembly

The invention also comprises a heated stripper shoe, a heated stripper shoe/mold assembly and a method of forming concrete masonry blocks with the shoe and mold assembly.

The stripper shoe and mold assembly generally includes a stripper shoe plate 70, having a lower side 75 and an upper side 77, Fig. 17A. The stripper shoe plate 70 may have indentations to form block details such as those shown at 79 on the shoe lower side 75, (see also 26 at Figs. 1 and 4). Heat elements 78 may be positioned on the stripper shoe plate upper side 77.

Positioned over the heat elements 78 on the upper surface of the shoe plate is a heat shroud 80 (shown in outline). The heat shroud lower side is configured to cover the heat elements 78. Once the heat shroud 80 is positioned over the upper surface 85 of the stripper shoe plate 70 wiring for the heat elements 78 may be passed through the heat shroud 80 and further into the head assembly.

The assembly may also comprise a standoff 90 which attaches the assembly to the block machine head 95. The standoff 90 is capable of spacing the stripper shoe plate 70 appropriately in the block machine and



insulating the head from the heat developed at the surface of the stripper shoe plate 70.

The assembly also comprises a mold 50 having an interior perimeter designed to complement the outer perimeter of the stripper shoe plate 70. The mold generally has an open center 63 bordered by the mold walls. Positioned beneath the mold is a pallet (not shown) used to contain the concrete fill in the mold and transport finished blocks from the molding machine.

10 The stripper shoe 70 serves as a substrate on which the heat elements 78 are contained. Further, the stripper shoe plate 70 also functions to form the body of the block as well as detail in the blocks through indentations 79 in the stripper shoe lower surface 75. 15 In use, the stripper shoe 70 functions to compress fill positioned in the mold and, once formed, push or strip the block from the mold 50.

The stripper shoe plate 70 may take any number of designs or forms including ornamentation or structural 20 features consistent with the block to be formed within the mold. Any number of steel alloys may be used in fabrication of the stripper shoe as long as these steel alloys have sufficient resilience and hardness to resist abrasives often used in concrete fill. Preferably, the 25 stripper shoe 70 is made from steel alloys which will resist continued compression and maintain machine tolerances while also transmitting heat from the heat elements through the plate 70 to the fill. In this manner, the total thermal effect of the heat elements is 30 realized within the concrete mix.

Preferably, the stripper shoe plate 70 is made from a carbonized steel which may further be heat treated after forging. Preferred metals include steel alloys having a Rockwell "C"-Scale rating from about 60-65 35 which provide optimal wear resistance and the preferred rigidity. Generally, metals also found useful include high grade carbon steel of 41-40 AISI (high nickel



content, prehardened steel), carbon steel 40-50 (having added nickel) and the like. A preferred material includes carbon steel having a structural ASTM of A36. Preferred steels also include A513 or A500 tubing, ASTM  
5 42-40 (prehardened on a Rockwell C Scale to 20 thousandths of an inch). The stripper shoe plate 70 may be formed and attached to the head assembly by any number of processes known to those of skill in the art including the nut, washer, and bolt mechanisms known to  
10 those of skill in the art.

One preferred heated stripper shoe design which complements the block mold is shown in Fig. 13B. The stripper shoe comprises a first section 72 and a second section 74, with the first section 74 having  
15 indentations 79 on the shoe lower side 75. A heat element 78 is positioned over indentation 79. The outer perimeter of the stripper shoe 70 may generally complement the interior outline of the mold 50. Heat elements 78 are preferably positioned adjacent to  
20 indentation 79 on the shoe lower side 75 to facilitate the formation of that point of detail created by the indentations 79 in the stripper shoe 70. While generally shown with one form of indentation 79, the stripper shoe plate 70 may be capable of forming any  
25 number of designs through indentations in the shoe plate lower surface 75 depending on the nature of the block to be formed.

The invention may also comprise one or more heat elements 78. Generally, the heat element 78 functions  
30 to generate and transmit radiant energy to the upper surface 77 of the stripper shoe 70. The heat elements are preferably positioned adjacent indentation 79 in the shoe plate lower surface 75.

Generally, any type and quantity of heat elements 78  
35 may be used in accordance with the invention. However, preferred heat elements have been found to be those which will withstand the heavy vibration, dirt and dust



common in this environment. Preferred heat elements are those which are easily introduced and removed from the system. This allows for easy servicing of the stripper shoe assembly without concerns for injury to the operator through thermal exposure or complete disassembly of mold 50, stripper shoe 70, shroud 80, and standoff 90.

The heat element may comprise any number of electrical resistance elements which may be, for example, hard wired, solid state, or semiconductor circuitry, among others. The heat element 78 may generally be positioned over indentations 79 in the stripper shoe lower surface 75, Fig. 13A. By this positioning, the heat element 78 is able to apply heat to the stripper shoe 70 in the area where it is most needed, that is, where the block detail (in this case, protrusion 26, see Fig. 1) is formed in the concrete mix held by the mold.

The heat element 78 may comprise any number of commercially available elements. Generally, the power provided by the heat element may range anywhere from 300 watts up to that required by the given application. Preferably, the power requirements of the heat element may range from about 400 watts to 1500 watts, more preferably 450 watts to 750 watts, and most preferably about 600 watts. Power may be provided to the heat elements by any number of power sources including for example, 110 volt sources equipped with 20 to 25 amp circuit breakers which allow the assembly to run off of normal residential current. If available, the assembly may also run off of power sources such as 3-phase, 220 volt sources equipped with 50 amp circuit breakers or other power sources known to those of skill in the art. However, the otherwise low power requirements of the assembly allow use in any environment with minimal power supplies.



Elements found useful in the invention include cartridge heaters, available from Vulcan Electric Company, through distributor such as Granger Industrial Co. of Minnesota. These elements have all been found to  
5 provide easy assembly and disassembly in the stripper shoe of the invention as well as good tolerance to vibration, dirt, dust, and other stresses encountered in such an environment.

Generally, the heat elements may be activated by  
10 hard wiring as well as any other variety of electrical feeds known to those of skill in the art. If hard wiring is used, provision may be made to circulate this wiring through the shroud 80 and standoff 90 by various openings 88. The heat element 78 may be externally  
15 controlled through any number of digital or analogue mechanisms known to those of skill in the art located at an external point on the block machine.

Heating the stripper shoe elements 78 allows the formation of block detail such as indentations or  
20 protrusions, or combinations thereof without the fouling of the shoe plate 70. Detail is essentially formed by case hardening the concrete fill adjacent the element 78. This allows the formation of block detail which is both ornate and has a high degree of structural  
25 integrity.

The invention may also comprise means of attaching the heat element 78 to the stripper shoe 70 such as a heat block. Examples of attachment means for the heat elements 76 may be seen in commonly assigned U.S. Patent  
30 Application No. 07/828,031, filed January 30, 1992, which is incorporated herein by reference.

The stripper shoe may also comprise a heat shroud 80 (shown in outline), Fig. 17A, which thermally shields or insulates the heat elements 78 and molding machine. The  
35 heat shroud 80 also functions to focus the heat generated by the heat elements 78 back onto the stripper shoe 70.

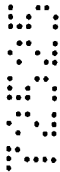

The heat shroud 80 may take any number of shapes of varying size in accordance with the invention. The heat shroud 80 should preferably contain the heat elements 78. To this end, the heat shroud 80 preferably has a void formed within its volume so that it may be placed over the heat elements 78 positioned on the upper surface 77 of the stripper shoe 70. At the same time, the shroud 80 is preferably positioned flush with the stripper shoe upper surface 77.

10 Preferably, there is a space between the upper surface of the heat element and the opening or void in the heat shroud 80. Air in this additional space also serves to insulate the standoff and mold machine from the heat created by the heat element 78.

15 Generally, the heat shroud 80 may comprise any metal alloy insulative to heat or which is a poor conductor of thermal energy. Metal alloys such as brass, copper, or composites thereof are all useful in forming the heat shroud 80. Also useful are aluminum and its oxides and  
20 alloys. Alloys and oxides of aluminum are preferred in the formation of the heat shroud 80 due to the ready commercial availability of these compounds. Aluminum alloys having an ASTM rating of 6061-T6 and 6063-T52 are generally preferred over elemental aluminum.

25 The assembly may additionally comprise a head standoff 90, attached to the stripper shoe plate 70, to position, aid in compression, and attach the head assembly to the block machine.

Generally, the head standoff 90 may comprise any  
30 number of designs to assist and serve this purpose. The head standoff may also be used to contain and store various wiring or other elements of the stripper shoe assembly which are not easily housed either on the stripper shoe 70, or the heat shroud 80.

35 The head standoff 90 may comprise any number of metal alloys which will withstand the environmental stresses of block molded processes. Preferred metals

include steel alloys having a Rockwell "C"-Scale rating from about 60-65 which provide optimal wear resistance and the preferred rigidity.

5 Generally, metals found useful in the manufacture of the head standoff mold of the present invention include high grade carbon steel of 41-40 AISI (high nickel content, prehardened steel), carbon steel 40-50 (having added nickel) and the like. A preferred material includes carbon steel having a structural ASTM of A36.

10 Generally, the head standoff 50 may be made through any number of mechanisms known to those of skill in the art.

The assembly may also comprise a mold 50. The mold generally functions to facilitate the formation of the blocks. Accordingly, the mold may comprise any material  
15 which will withstand the pressure to be applied to the block filled by the head. Preferably, metal such as steel alloys having a Rockwell "C"-Scale rating from about 60-65 which provide optimal wear resistance and the preferred rigidity.

20 Generally, other metals found useful in the manufacture of the mold of the present invention include high grade carbon steel of 41-40 AISI (high nickel content, prehardened steel), carbon steel 40-50 (having added nickel) and the like. A preferred material  
25 includes carbon steel having a structural ASTM of A36.

Mold 50 useful in the invention may take any number of shapes depending on the shape of the block to be formed and be made by any number of means known to those of skill in the art. Generally, the mold is produced by  
30 cutting the steel stock, patterning the cut steel, providing an initial weld to the pattern mold pieces and heat treating the mold. Heat treating generally may take place at temperatures ranging from about 1000°F to about 1400°F from 4 to 10 hours depending on the ability  
35 of the steel to withstand processing and not distort or warp. After heat treating, final welds are then applied to the pieces of the mold.

Turning to the individual elements of the mold, the mold walls generally function according to their form by withstanding the pressure created by the block machine. Further, the walls measure the height and the depth of resulting blocks. The mold walls must be made of a thickness which will accommodate the processing parameters of the block formation given a specific mold composition.

Generally, as can be seen in Fig. 17B, the mold comprises a front surface 52, back surface 54, as well as a first side surface 51, and a second side surface 58. As noted, each of these surfaces function to hold fill within a contained area during compression, thus resulting in the formation of a block. Accordingly, each of these mold surfaces may take a shape consistent with this function.

The mold side walls, 51 and 58, may also take any shape in accordance with the function of the mold. Preferably, the side walls each comprise an extension 64 which are useful in forming the insets 22A and 22B in the block of the invention, see Fig. 1. In order to form insets 22A and 22B in the block of the invention, extension 64 may have a dimension which is fairly regular over the depth of the mold.

However, if insets 22A and 22B are required which have a conical shape as seen in Figs. 2 and 5, the extensions may be formed to have a width at the top of the mold which is greater than the width of the extension at the bottom of the mold. This will result in the insets 22A and 22B which are seen in the various embodiments of the block of the invention shown in Figs. 1-6 as well as Figs. 9-11 while also allowing stripping of the block from the mold 50 during processing.

The mold may preferably also comprise one or more support bars 60 and core forms 62. The support bars 60 hold the core forms 62 in place within the mold cavity 63. Here again, the support bars may take any shape,





size, or material composition which provides for these functions.

As can be seen more clearly in Fig. 17B, support bar 60 is preferably long enough to span the width of the mold 50 resting on opposing side walls 51 and 59. The support bar 60 functions to hold the core 62 within the mold central opening 63. Complementing this function, the support bar 60 is generally positioned in the central area 63A of the opposing side walls 51 and 58. The core form 62 may also be held in place by an additional support 62A (shown in outline) placed between the back wall 54 of the mold 50 and the core form 62. Support bar 60 may also be held in place by a bracket 85 affixed above and around the outer perimeter of the mold 50 at the edges of walls 51, 52, 58, and 54. The use of these various support structures reduces core form vibration during the molding process.

As can be seen in the outline on Fig. 17B, the core form 62 are supported by bar 60 which span the width of the mold 50 resting on the opposing side walls 51 and 58. The core forms have any number of functions. The core forms 62 act to form voids in the resulting composite masonry block. In turn, the core forms lighten the blocks, reduce the amount of fill necessary to make a block, and add to the portability and handleability of the blocks to assist in transport and placement of the blocks.

Also preferred as can be seen in the view provided in Fig. 13B, the core form 62 is affixed to the support bar 60 at insert regions 60A. These insert regions 60A assist in positioning the core forms. As can be seen, the support bar 60 projects upwards from mold 50. As a result, the stripper shoe 70 and stand off 80 may be partitioned or split as can be seen by openings 76 and 96, respectively (Fig. 17A). The separate sections of the shoe 70 and stand off will allow adequate compression of the fill without obstruction by the



support bar 60. In turn, the various sections of the stripper shoe 70 and stand off 90 may be held in place by the head 95.

While the mold of the invention may be assembled through any number of means, one manner is that shown in Fig. 17B. Preferably, the mold is held in place by two outer beams 55 and 56, each of which have an interior indentation, 61 and 67 respectively. As can be seen, bolt elements 57 may be fit into the front wall 52 and back wall 54 of the mold 50. The side walls 51 and 58 of the mold may be held in the outer beams of the mold by nut plates 65 sized to fit in indentations 61 and 67. In turn the nut plates 65 may be held within the outer beam indentations 61 by bolt means 53. In this manner, the mold 50 may be held in place even though constructed of a number of pieces.

Block Molding

An additional aspect of the present invention is the process for casting or forming the composite masonry blocks of this invention using a masonry block mold assembly, Figs. 13A and 13B. Generally, the process for making this invention includes block molding the composite masonry block by filling a block mold with mix and casting the block by compressing the mix in the mold through the application of pressure to the exposed mix at the open upper end of the block mold. An outline of the process can be seen in the flow chart shown in Fig. 18.

In operation, the assembly is generally positioned in the block molding machine atop of a removable or slidable pallet (not shown). The mold 50 is then loaded with block mix or fill. As configured in Figs. 17A and 17B, the mold 50 is set to form one block. Once formed and cured, these blocks may be split along the deflections created by flanges 66 which may be positioned on the interior of sidewalls of the mold. Prior to compression, the upper surface of the mold is

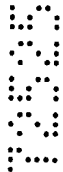

vibrated to settle the fill and scraped or raked with the feed box drawer (not shown) to remove any excess fill. The mold is then subjected to compression directly by the stripper shoe 70 through head assembly.

5 Upon compression, the stripper shoe 70 forces block fill towards either end of the mold and into the stripper shoe indentation 79 to create a protrusion 26 in the formed block, see Fig. 1. This indentation may range in size for example from about 1 to 3 inches,  
10 preferably about 1-1/2 to 2-1/2 inches, and most preferably about 1-3/4 to 2 inches.

In accordance with the invention, this indentation 79 is heated by elements 78 so that protrusions 26 of minimal size and varying shape may be formed without the  
15 build up of fill on the stripper shoe 70 at indentation 79. By doing so, the assembly may be used in the automatic manufacture of blocks by machine.

Blocks may be designed around any number of different physical properties in accordance with ASTM  
20 Standards depending upon the ultimate application for the block. For example, the fill may comprise from 75 to 95% aggregate being sand and gravel in varying ratios depending upon the physical characteristics which the finished block is intended to exhibit. The fill  
25 generally also comprises some type of cement at a concentration ranging from 4% to 10%. Other constituents may then be added to the fill at various trace levels in order to provide blocks having the intended physical characteristics.

30 Generally, once determined the fill constituents may be mixed by combining the aggregate, the sand and rock in the mixer followed by the cement. After one to two and one-half minutes, any plasticizers that will be used are added. Water is then introduced into the fill in  
35 pulses over a one to two minute period. The concentration of water in the mix may be monitored electrically by noting the electrical resistance of the

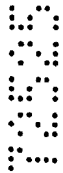

mix at various times during the process. While the amount of water may vary from one fill formulation to another fill formulation, it generally ranges from about 1% to about 6%.

5       Once the mold has been filled, leveled by means such as a feed box drawer, and agitated, a compression mechanism such as a head carrying the inventive assembly converges on the exposed surface of the fill. The  
10       stripper shoe assembly 30 acts to compress the fill within the mold for a period of time sufficient to form a solid contiguous product. Generally, the compression time may be anywhere from 0.5 to 4 seconds and more preferably about 1.5 to 2 seconds. The compression pressure applied to the head ranges from about 1000 to  
15       about 8000 psi and preferably is about 4000 psi.

      Once the compression period is over, the stripper shoe 70 in combination with the underlying pallet acts to strip the blocks from the mold 50. At this point in time the blocks are formed. Any block machine known to  
20       those of skill in the art may be used in accordance with the invention. One machine which has been found useful in the formation of blocks is a Besser V-3/12 block machine.

      Generally, during or prior to compression the mold  
25       may be vibrated. The fill is transported from the mixer to a hopper which then fills the mold 50. The mold is then agitated for up to 2 to 3 seconds, the time necessary to ensure the fill has uniformly spread throughout the mold. The blocks are then formed by  
30       compressive action by the compressive action the head. Additionally, this vibrating may occur in concert with the compressive action of the head onto the fill in the mold. At this time, the mold will be vibrated for the time in which the head is compressed onto the fill.

35       Once the blocks are formed, they may be cured through any means known to those with skill in the art. Curing mechanisms such as simple air curing,

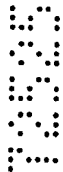

autoclaving, steam curing or mist curing, are all useful methods of curing the block of the present invention. Air curing simply entails placing the blocks in an environment where they will be cured by open air over  
5 time. Autoclaving entails placing the blocks in a pressurized chamber at an elevated temperature for a certain period of time. The pressure in the chamber is then increased by creating a steady mist in the chamber. After curing is complete, the pressure is released from  
10 the chamber which in turns draws the moisture from the blocks.

Another means for curing blocks is by steam. The chamber temperature is slowly increased over two to three hours and then stabilized during the fourth hour.  
15 The steam is gradually shut down and the blocks are held at the eventual temperature, generally around 120 - 200°F for two to three hours. The heat is then turned off and the blocks are allowed to cool. In all instances, the blocks are generally allowed to sit for  
20 12 to 24 hours before being stacked or stored. Critical to curing operations is a slow increase in temperature. If the temperature is increased too quickly, the blocks may "case-harden". Case hardening occurs when the outer shell of the block hardens and cures while the inner  
25 region of the block remains uncured and moist. While any of these curing mechanisms will work, the preferred mechanism is autoclaving.

Once cured the blocks may be split to create any number of functional or aesthetic features in the  
30 blocks. Splitting means which may be used in the invention include manual chisel and hammer as well as machines known to those with skill in the art. Flanges 66 (Fig. 9) may be positioned on the interior of the mold 50 side walls to provide a natural weak point or  
35 fault which facilitates the splitting action. The blocks may be split in a manner which provides a front surface 12 which is smooth or coarse (Figs. 1-6 and



Figs. 9-11), single faceted (Fig.1) ore multifaceted (Fig.4), as well as planar or curved. For example, the blocks may be split to provide a faceted front surface as shown in Figs, 4-6 by surface 12A, 12 and 12B. Preferably, 5 splitting will be completed by an automatic hydraulic splitter. When split, the blocks may be cubed and stored. Once split, the blocks may be cubed and stored.

The above discussion, examples, and embodiments 10 illustrate our current understanding of the invention. However, since many variations of the invention can be made without departing from the spirit and scope of the invention, the invention resides wholly in the claims hereafter appended.

15 In the claims which follow and in the receding description of the invention, the words "comprising" and "comprises" are used in the sense of the word "including" and "includes", ie the features referred to in connection 20 with these words may be associated with other features that are not expressly described.



THE CLAIMS DEFINING THE INVENTION ARE AS FOLLOWS:

1. A retaining wall block suitable for production on automated masonry block manufacturing equipment employing  
5 a concrete mixture comprising water in a concentration range of between about 1% and about 6% by weight, said block comprising:

10 a block body having a front, a back, a top, a bottom, and first and second sides, wherein the block body front comprises a front surface that has a roughened texture, said block body top and said block body bottom being  
15 configured so that when a plurality of like blocks are stacked in ascending courses to form a wall, at least a portion of the bottom of the blocks in an upper course rest upon at least a portion of the top of the adjacent blocks in the next lower course so that the tops of the blocks in said upper course are generally horizontal;

20 a first inset in said first side extending from said block top to said block bottom,

a second inset in said second side extending from said block top to said block bottom,

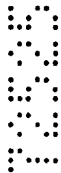

25 one or more locator protrusions formed integrally with the block body and located on said block body top or on said block body bottom,

30 wherein at least a portion of each locator protrusion is adapted to fit within an inset on a block in an adjacent course of blocks when a plurality of the blocks are stacked in ascending courses to form a wall, each locator protrusion having a smaller front-to-back

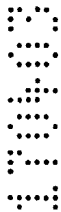

35 dimension than the front-to-back dimension of its corresponding inset so that when a plurality of the blocks are stacked in ascending courses, portions of the insets and locator protrusions of adjacent blocks in adjacent courses contact each other in a shear-resisting position in which interference between the locator protrusions and insets resist the tendency of a block in the upper course to slide forwardly in response to the

anticipated forces that will be exerted on the block by retained earth, and in which there is not interference between the locator protrusions and insets that will resist at least some rearward shifting of the upper course block; and wherein the locator protrusions and insets are sized and shaped to permit relative rotation of the insets and protrusions to thereby facilitate the construction of serpentine walls while maintaining said shear-resisting position.

10 2. The block of claim 1, wherein said first and second insets are positioned at approximately the midpoint of said first and second sides, respectively.

15 3. The block of claim 1 or 2, wherein said first and second insets are positioned proximate said block body front.

20 4. The block according to any one of claims 1 to 3, wherein the block body back comprises a back surface that is narrower than the block body front and wherein the block further comprises an opposed pair of legs extending from opposite ends of the back surface.

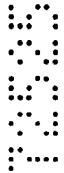

25 5. The block according to any one of claims 1 to 4, in which the block comprises a pair of locator protrusions.

30 6. The block according to any one of claims 1 to 4, in which the block comprises a single locator protrusion.



35 7. The block according to any one of claims 1 to 4, in which the locator protrusion comprises two lobes and a narrowed portion between the lobes.

8. The block according to any one of the preceding claims in which the one or more locator protrusions are



formed on the block body in such a location relative to the insets that, when a plurality of like blocks are stacked in ascending courses, and the protrusions and insets are configured in the shear-resisting position, the  
5 blocks in each ascending course are set back from the blocks in the adjacent course below.

9. The block according to any one of the preceding claims wherein said block body has an open core portion  
10 extending from said top to said bottom.

10. The block according to any one of the preceding claims wherein at least a portion of each protrusion has a curved side that is configured to contact an inset in a  
15 block in an adjacent course of blocks in the shear resisting position.

11. A retaining wall block comprising:  
a front surface having a rough texture, a back  
20 surface, a top surface having at least a contact portion thereof that is generally horizontal and generally planar, a bottom surface having at least a contact portion thereof that is generally horizontal and generally planar and that is configured and adapted to rest upon the contact portion  
25 of the top surface of a like block when a plurality of like blocks are stacked in ascending courses, and first and second sides,

a first inset in said first side, and a second inset in said second side, each said inset being delimited by a  
30 front wall and a back wall that each extend inwardly towards the opposite side, and a wall interconnecting said front and back walls, said front, back and interconnecting walls each having a height that is substantially equal to the distance between said generally horizontal and  
35 generally planar contact portions of said top surface and said bottom surface, and

one or more locator protrusions integrally formed on said top or bottom surface,

wherein each locator protrusion is adapted to fit within an inset on a block in an adjacent course of blocks  
5 when a plurality of like blocks are stacked in ascending courses to form a retaining wall so that the insets and locator protrusions of adjacent blocks in adjacent courses contact each other in a shear-resisting position in which interference between the locator protrusions and insets  
10 resist the tendency of a block in the upper course to slide forwardly in response to the anticipated forces that will be exerted on the block by retained earth, and in which there is not interference between the locator protrusions and insets that will resist at least some  
15 rearward shifting of the upper course block; and wherein the locator protrusions and insets are sized and shaped to permit relative rotation of the insets and protrusions to thereby facilitate the construction of serpentine walls while maintaining said shear-resisting position.

20  
12. The block of claim 11 in which the one or more locator protrusions are formed on the block body in such a location relative to the insets that, when a plurality of like blocks are stacked in ascending courses, and the  
25 protrusions and insets are configured in the shear-resisting position, the blocks in each ascending course are set back from the blocks in the adjacent course below.

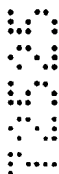

30  
13. The block according to claim 11 or 12, wherein, for each said inset, said front and back walls are substantially parallel to each other.



35  
14. The block according to any one of claims 11 to 13, wherein said front and back walls are substantially parallel to said back surface.

15. The block according to any one of claims 11 to 14, wherein, for each said inset, the length of said front wall is greater than the length of said back wall.

5 16. The block according to any one of claims 11 to 15, wherein, for each said inset, the height of said front, back and interconnecting walls is generally constant.

10 17. The block according to any one of claims 11 to 16, wherein the one or more protrusions each include a curved portion that is configured to contact the front or back wall of an inset in the shear resisting position.

15 18. The block according to any one of claims 11 to 17, wherein the distance between said generally horizontal and generally planar portions of said top surface and said bottom surface is substantially equal to the height of said front surface.

20 19. A retaining wall block comprising:  
a front surface having a rough texture, a back surface, a top surface having at least a contact portion thereof that is generally horizontal and generally planar, a bottom surface having at least a contact portion thereof that is generally horizontal and generally planar and that is configured and adapted to rest upon the contact portion of the top surface of a like block when a plurality of like blocks are stacked in ascending courses, and first and second sides,

25  
30 a first inset in said first side, and a second inset in said second side, each said inset being delimited by a front wall and a back wall that extend inwardly towards the opposite side, and a curved wall interconnecting said front and back walls, said front, back and curved walls each having a height that is substantially equal to the distance between said generally horizontal and generally  
35

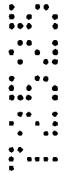

planar contact portions of said top surface and said bottom surface, and

5 a locator protrusion integrally formed on said top or bottom surface, wherein said locator protrusion comprises first and second curved end sections between which is positioned a joining section,

10 wherein said locator protrusion is adapted to fit within an inset on a block in an adjacent course of blocks when a plurality of the blocks are stacked in courses to form a retaining wall, and wherein said locator protrusion has a smaller front-to-back dimension than the front-to-back dimension of its corresponding inset so that when a plurality of the blocks are stacked in ascending courses, the insets and locator protrusions of adjacent blocks in adjacent courses contact each other in a shear-resisting position in which interference between the locator protrusions and insets resist the tendency of a block in the upper course to slide forwardly in response to the anticipated forces that will be exerted on the block by retained earth, and in which there is not interference between the locator protrusions and insets that will resist at least some rearward shifting of the upper course block; and wherein the locator protrusions and insets are sized and shaped to permit relative rotation of the insets and protrusions to thereby facilitate the construction of serpentine walls while maintaining said shear-resisting position.

20. The block of claim 19, wherein said joining section has a narrower width than either of said curved sections.

21. The block according to claim 19 or 20, wherein said first and second insets are positioned at approximately the midpoint of said first and second sides, respectively.

22. The block according to any one of claims 19 to 21, wherein said first and second insets are positioned proximate said front surface.

5 23. The block according to any one of claims 19 to 22 further comprising an opposed pair of legs extending from opposite ends of the back surface.

10 24. The block according to any one of claims 19 to 23, wherein said block front surface is substantially planar.

25. The block according to any one of claims 19 to 23, wherein said block front surface is faceted.

15 26. The block according to any one of claims 19 to 23, wherein said block front surface is outwardly curving.

20 27. The block according to any one of claims 19 to 26, in which the locator protrusion is formed on the block body in such a location relative to the insets that, when a plurality of like blocks are stacked in ascending courses, and the protrusion and inset are configured in the shear resisting position, the blocks in each ascending course are set back from the blocks in the adjacent course below.



25 28. The block according to any one of claims 19 to 27, wherein said protrusion is positioned between said first and second insets.

30 29. The block according to any one of claims 19 to 28, wherein said block has an open core portion extending from said top surface to said bottom surface.

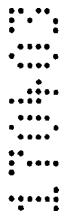

35 30. The block according to any one of claims 19 to 29, wherein said first and second sides extend from said front

surface to said back surface, and said sides converge together toward said back surface.

31. The block according to any one of claims 19 to 30,  
5 wherein at least a portion of one of said curved end sections is configured to contact at least a portion of an inset in a block in an adjacent course of blocks in the shear resisting position.

10 Dated this 15th day of April 2003

ANCHOR WALL SYSTEMS, INC

and DICK J SIEVERT

and MICHAEL E WOOLFORD

By their Patent Attorneys

15 GRIFFITH HACK

Fellows Institute of Patent and

Trade Mark Attorneys of Australia



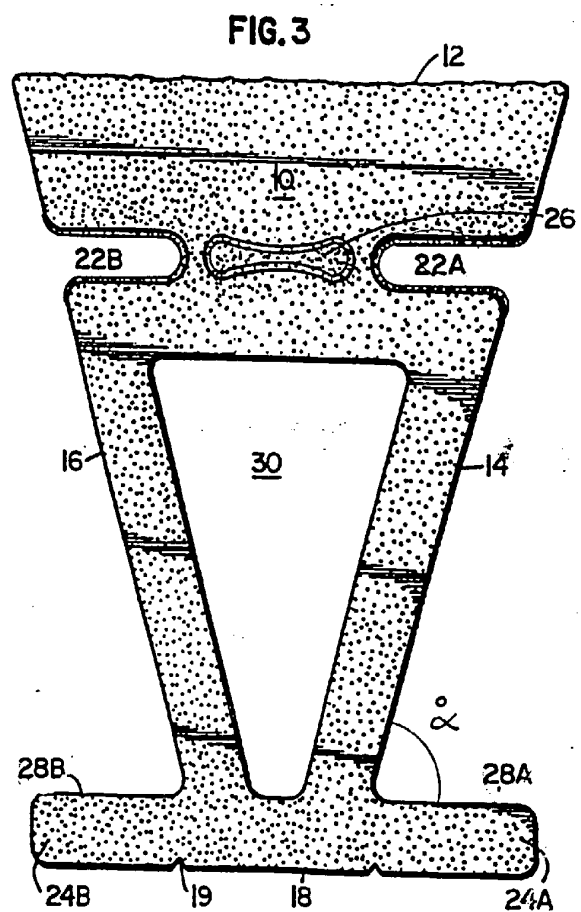
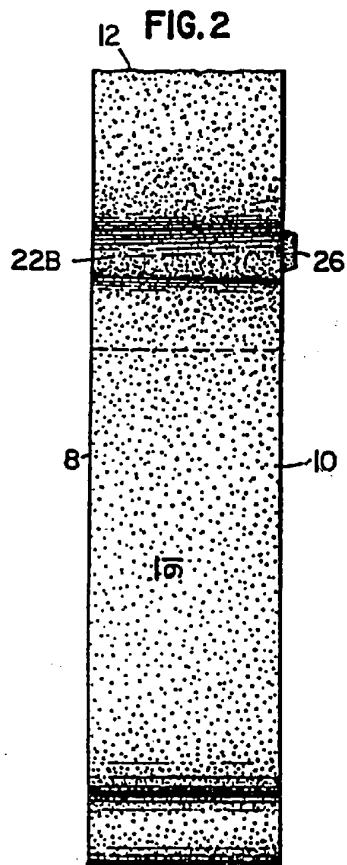
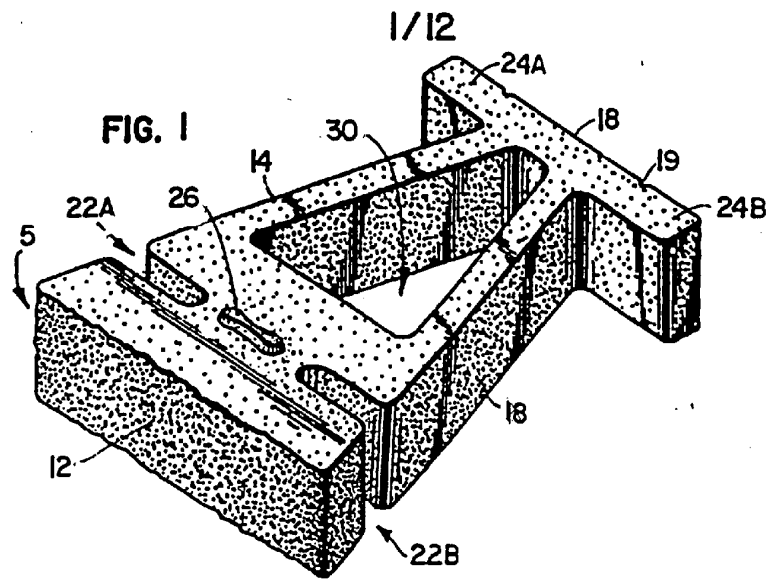

FIG. 4

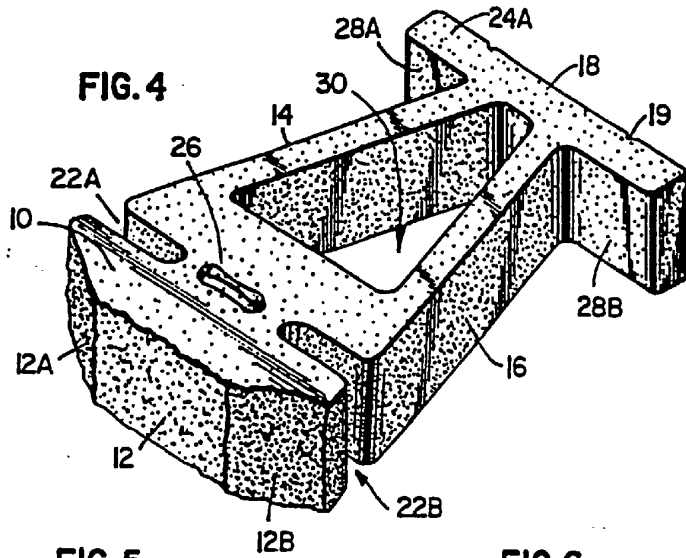

FIG. 5

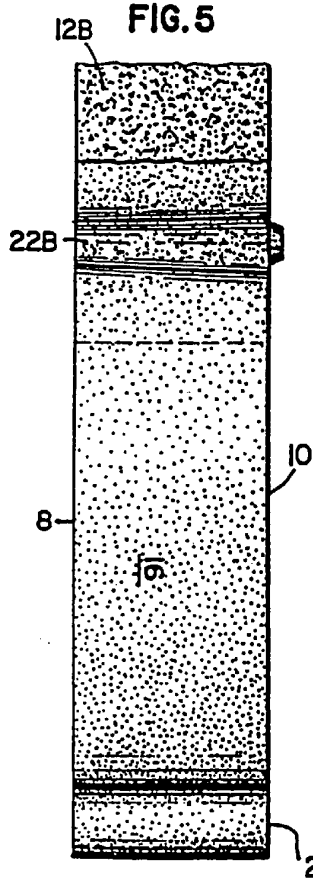
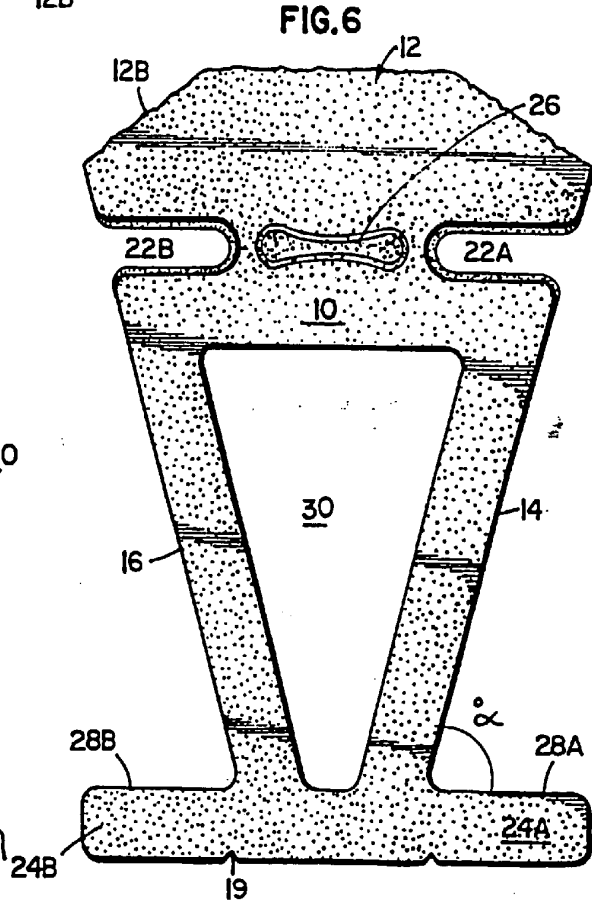

FIG. 6





3/12

FIG. 7

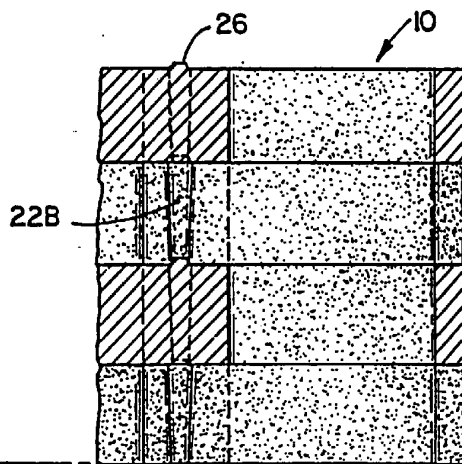
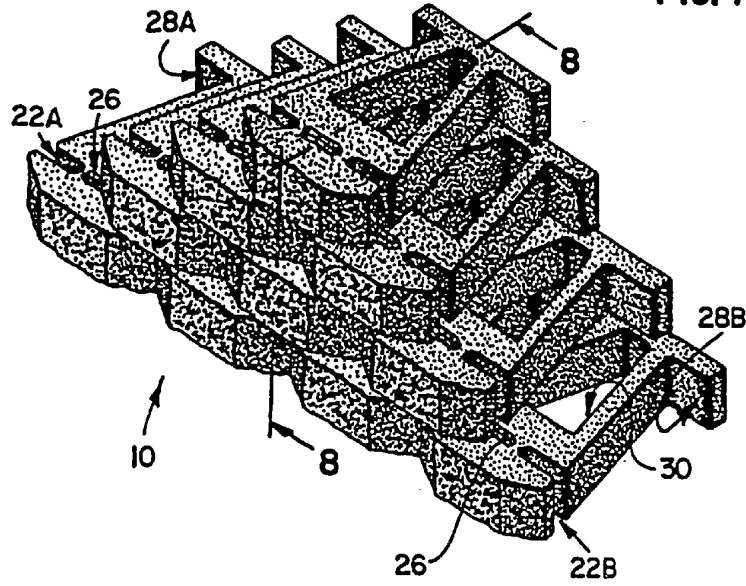

FIG. 8

FIG. 9

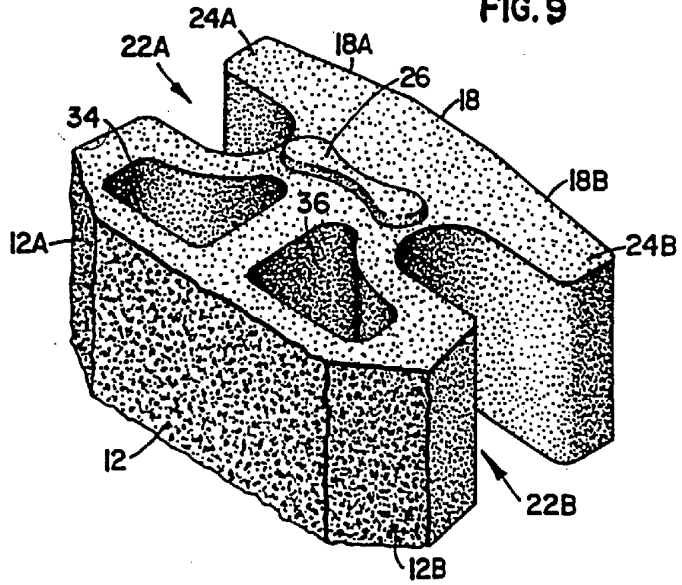
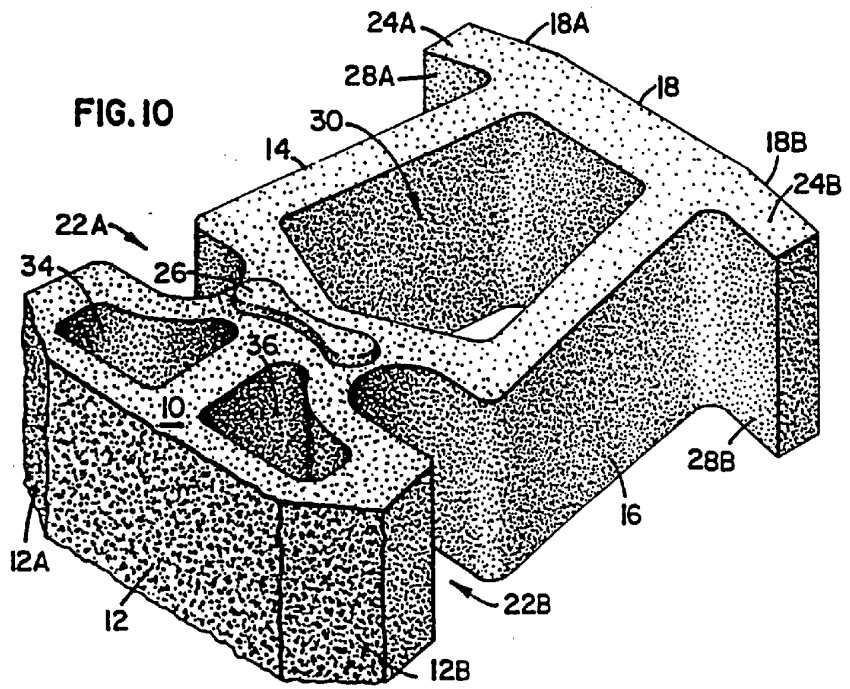
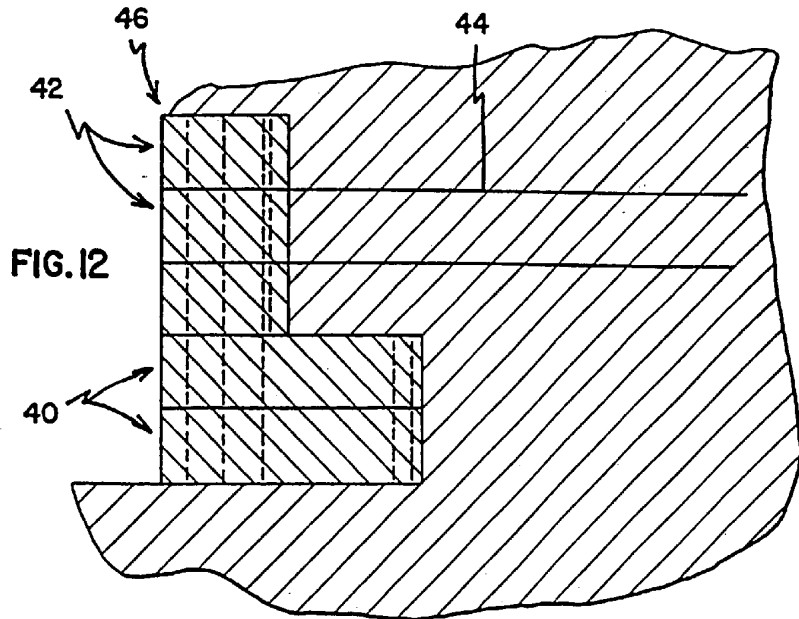
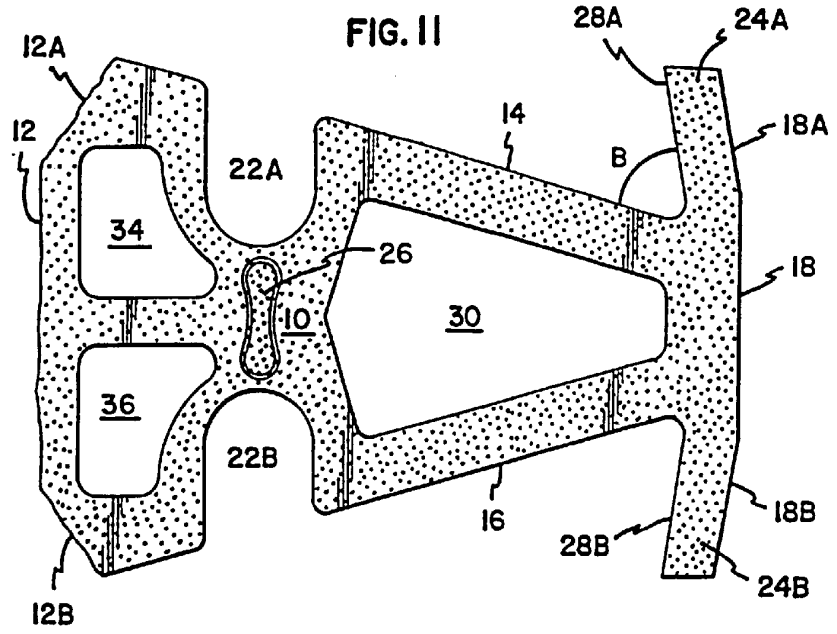

FIG. 10





5  
2  
3  
4  
5

FIG. 13

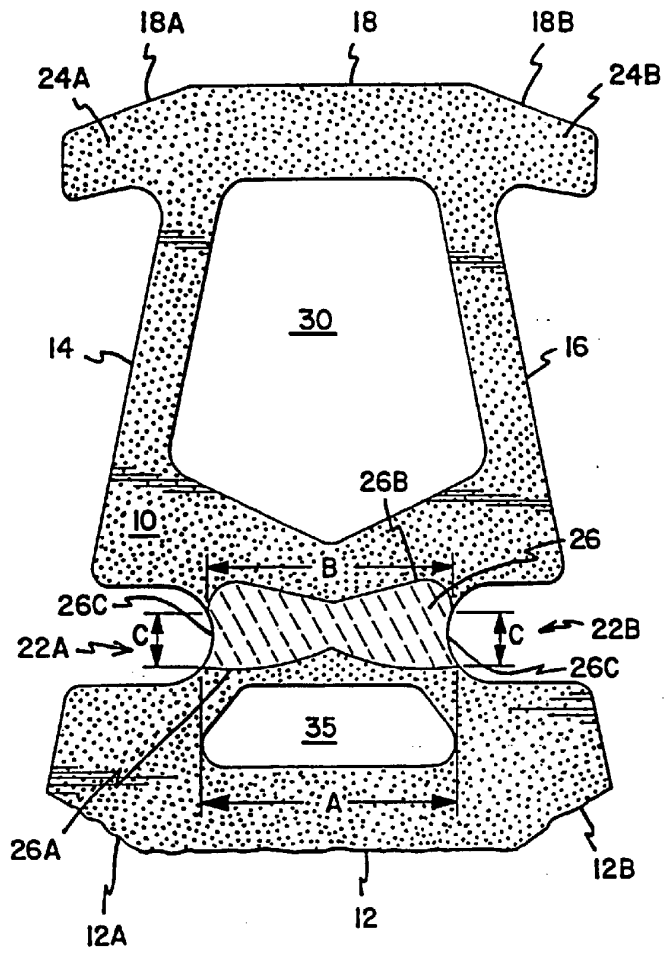
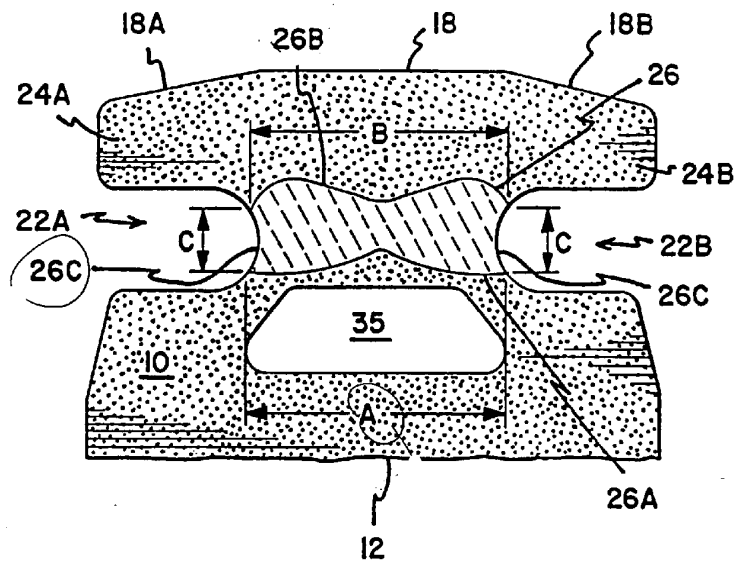

FIG. 14



2  
2  
2  
2

8/12

FIG. 15

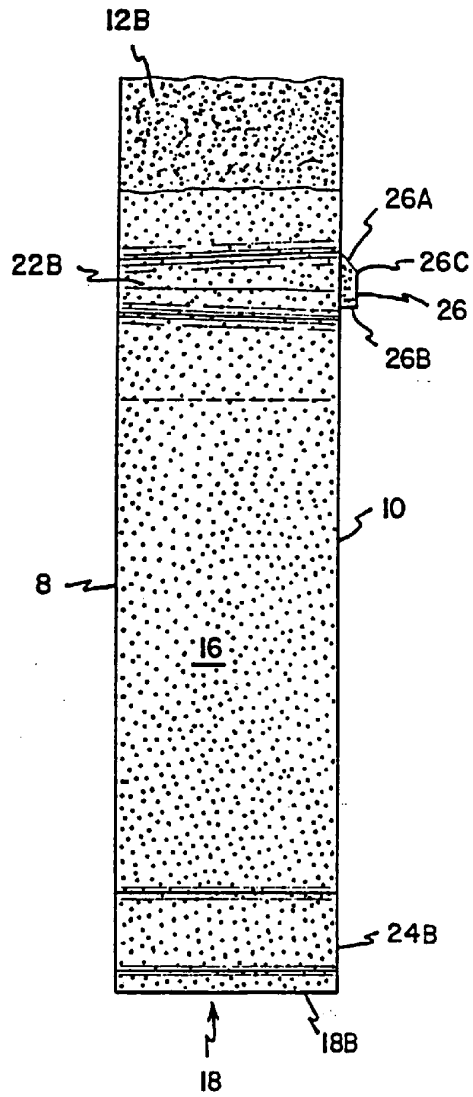
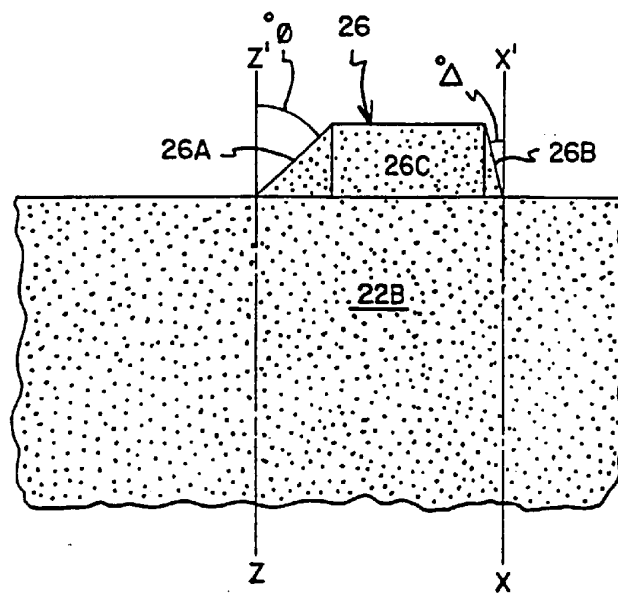

FIG. 16



9  
2  
3  
4  
8

FIG. 17A

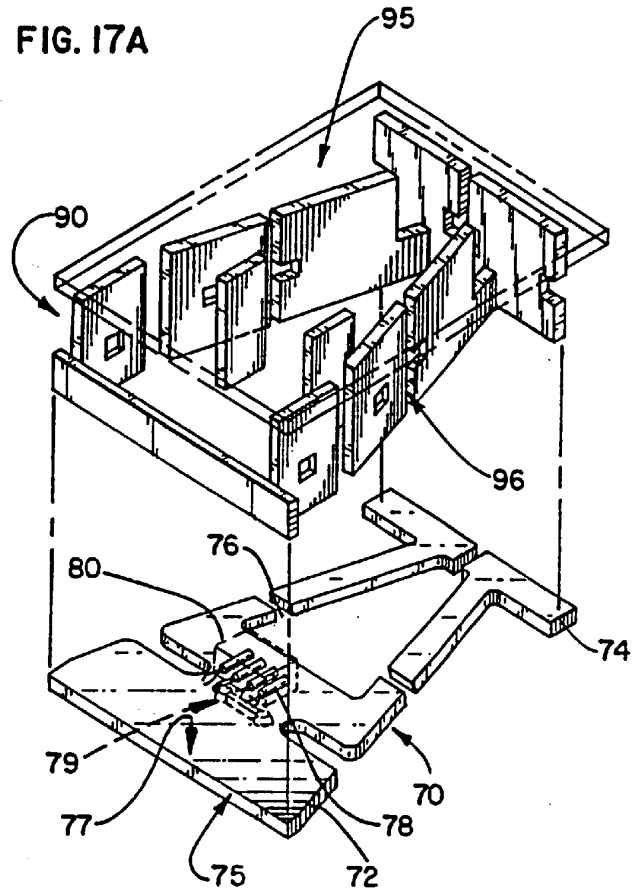



FIG. 17B

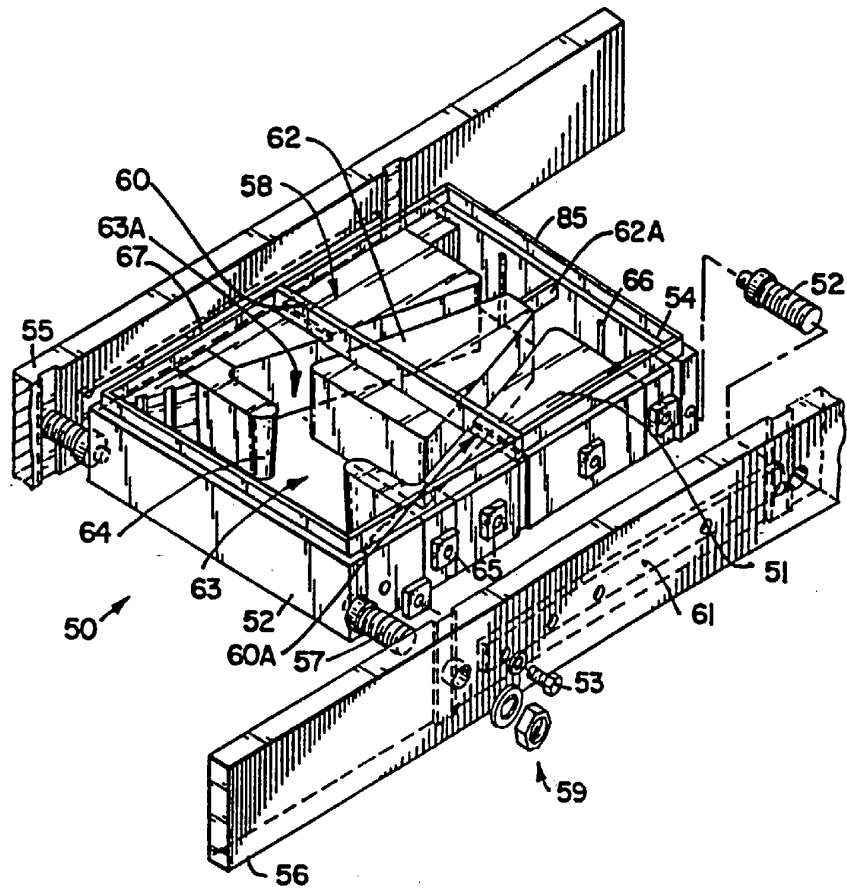
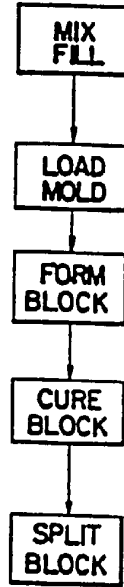

FIG.18



2  
2  
3  
4  
4