



US 20050247062A1

(19) **United States**

(12) **Patent Application Publication**
Jeppel et al.

(10) **Pub. No.: US 2005/0247062 A1**

(43) **Pub. Date: Nov. 10, 2005**

(54) **GAS TURBINE**

(30) **Foreign Application Priority Data**

(76) Inventors: **Paul-Heinz Jeppel**, Waltrop (DE);
Wilhelm Schulten, Essen (DE)

Sep. 13, 2002 (EP)..... 02020694.2

Publication Classification

(51) **Int. Cl.⁷** **F23R 3/42**

(52) **U.S. Cl.** **60/752; 60/806**

Correspondence Address:
Siemens Corporation
Intellectual Property Department
170 Wood avenue South
Iselin, NJ 08830 (US)

(57) **ABSTRACT**

The invention relates to a gas turbine comprising a combustion chamber, into which fuel and combustion air are fed and caused to react, in order to produce a working fluid. The aim of the invention is to provide a particularly simple construction, which achieves a relatively high degree of efficiency for the installation. To achieve this, the inventive combustion chamber can be cooled and has a tubular structure, the combustion chamber wall being composed of coolant pipes.

(21) Appl. No.: **10/525,780**

(22) PCT Filed: **Sep. 1, 2003**

(86) PCT No.: **PCT/EP03/09703**

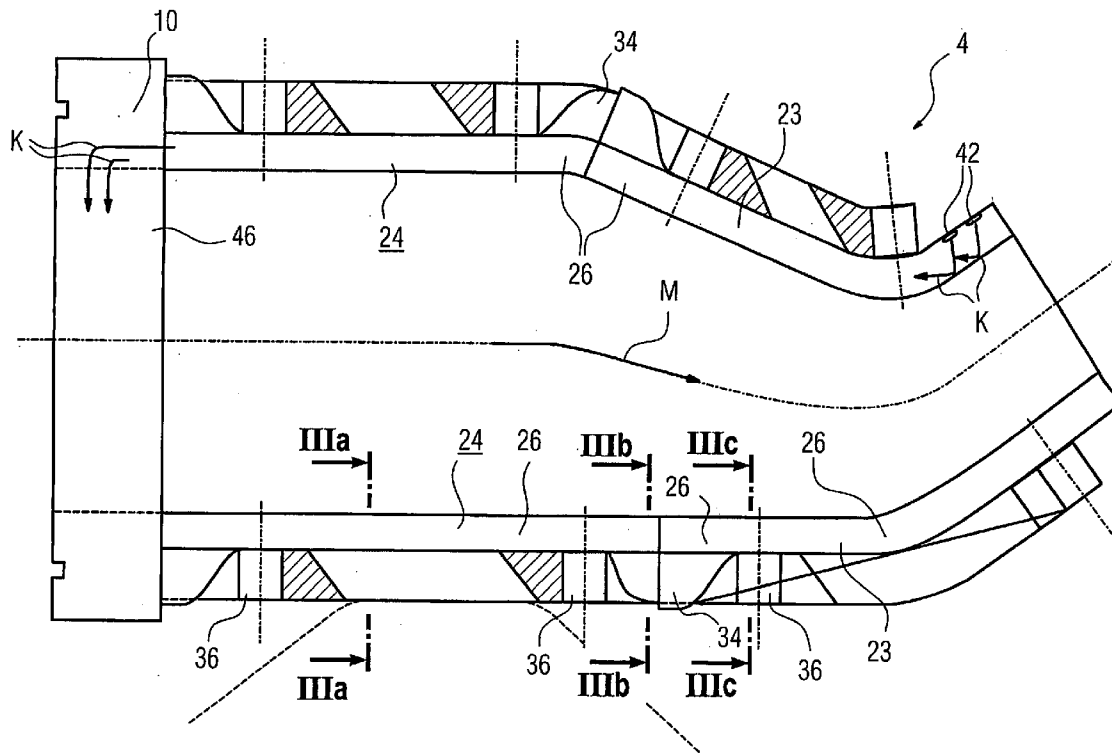

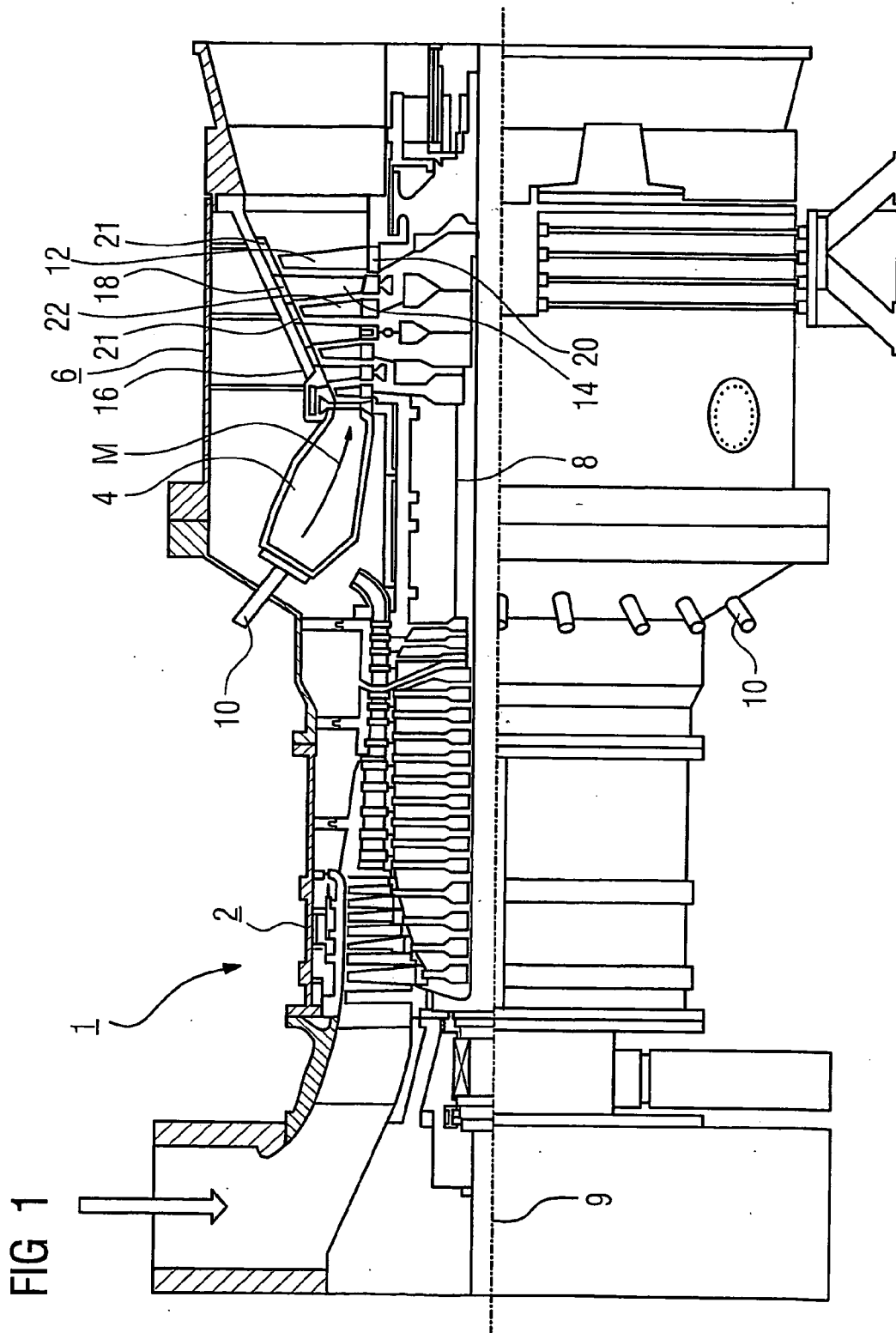

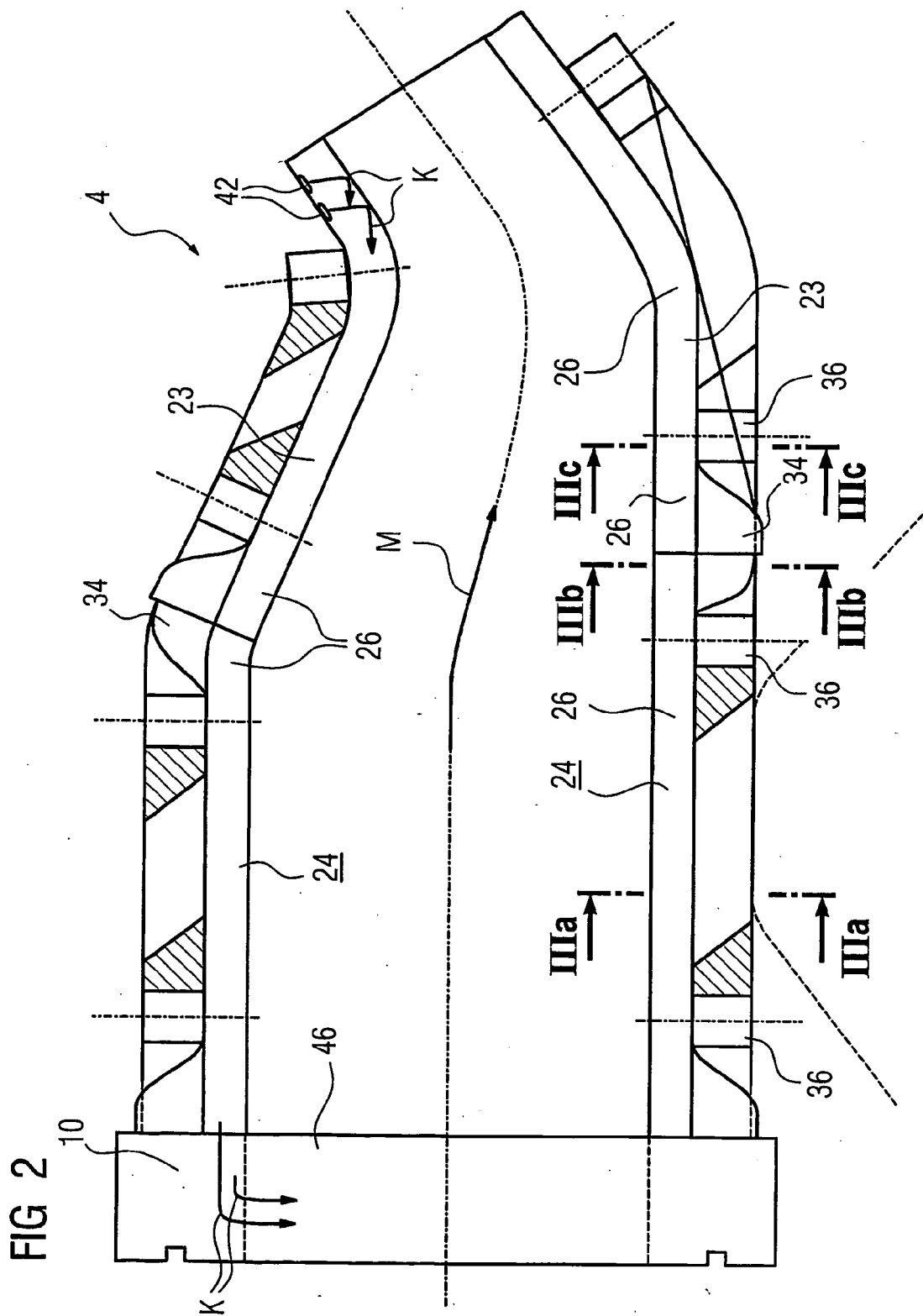
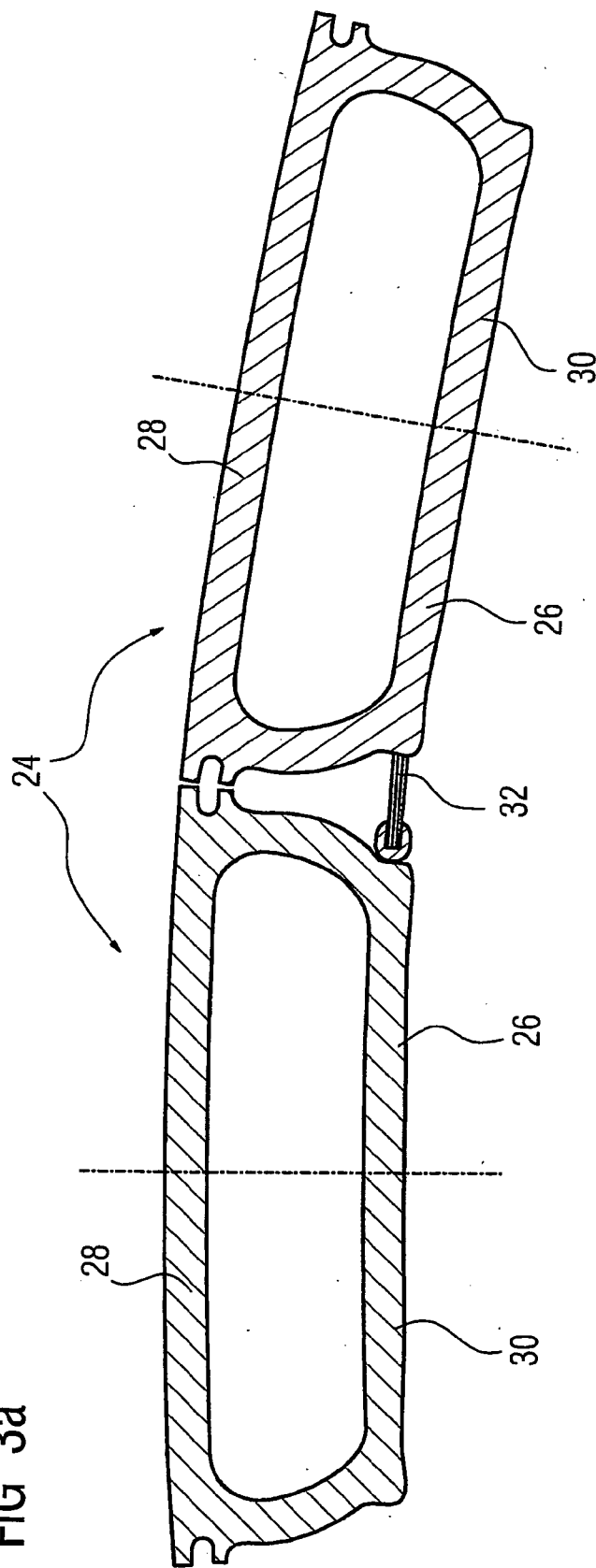

FIG 2

FIG 3a



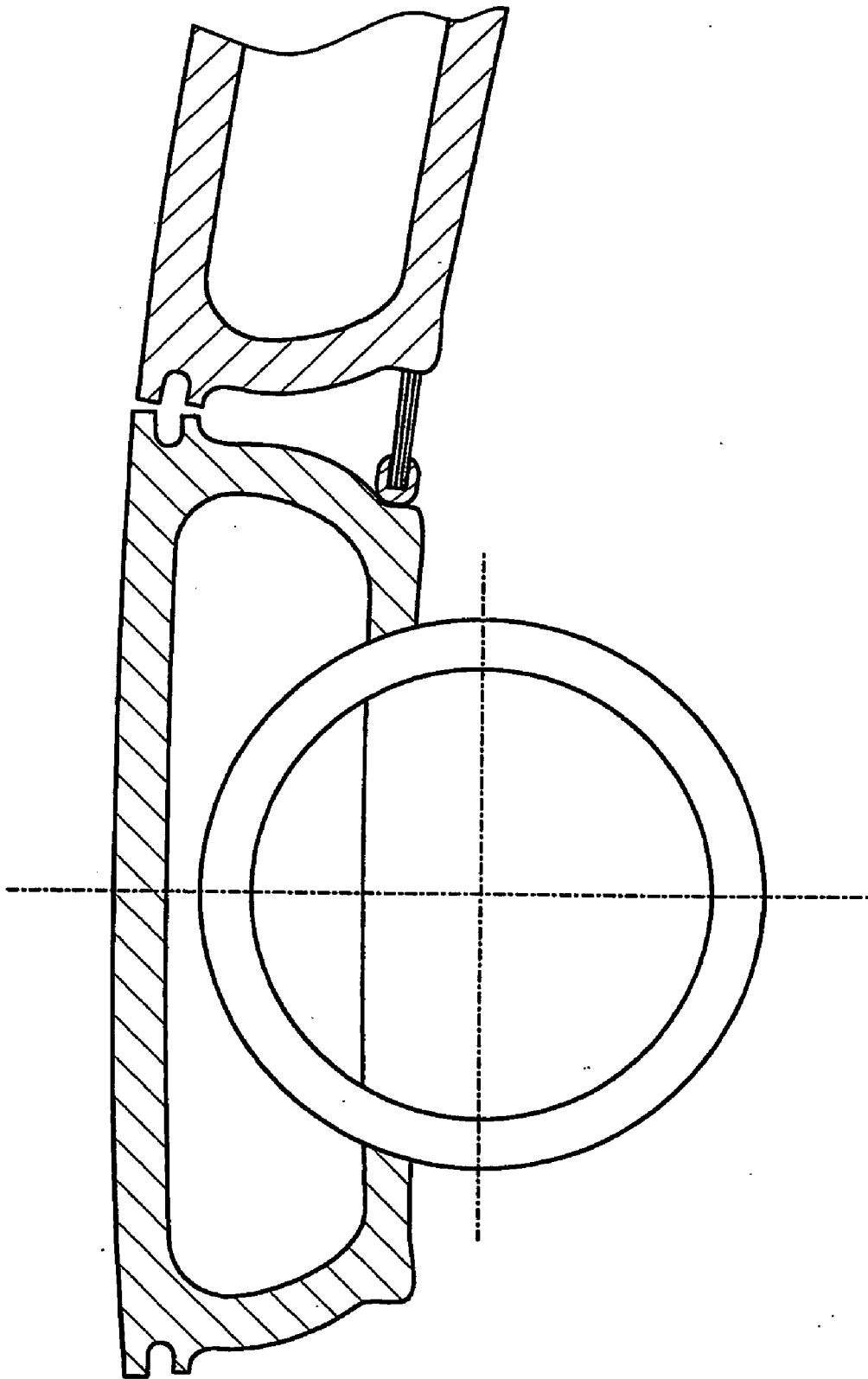
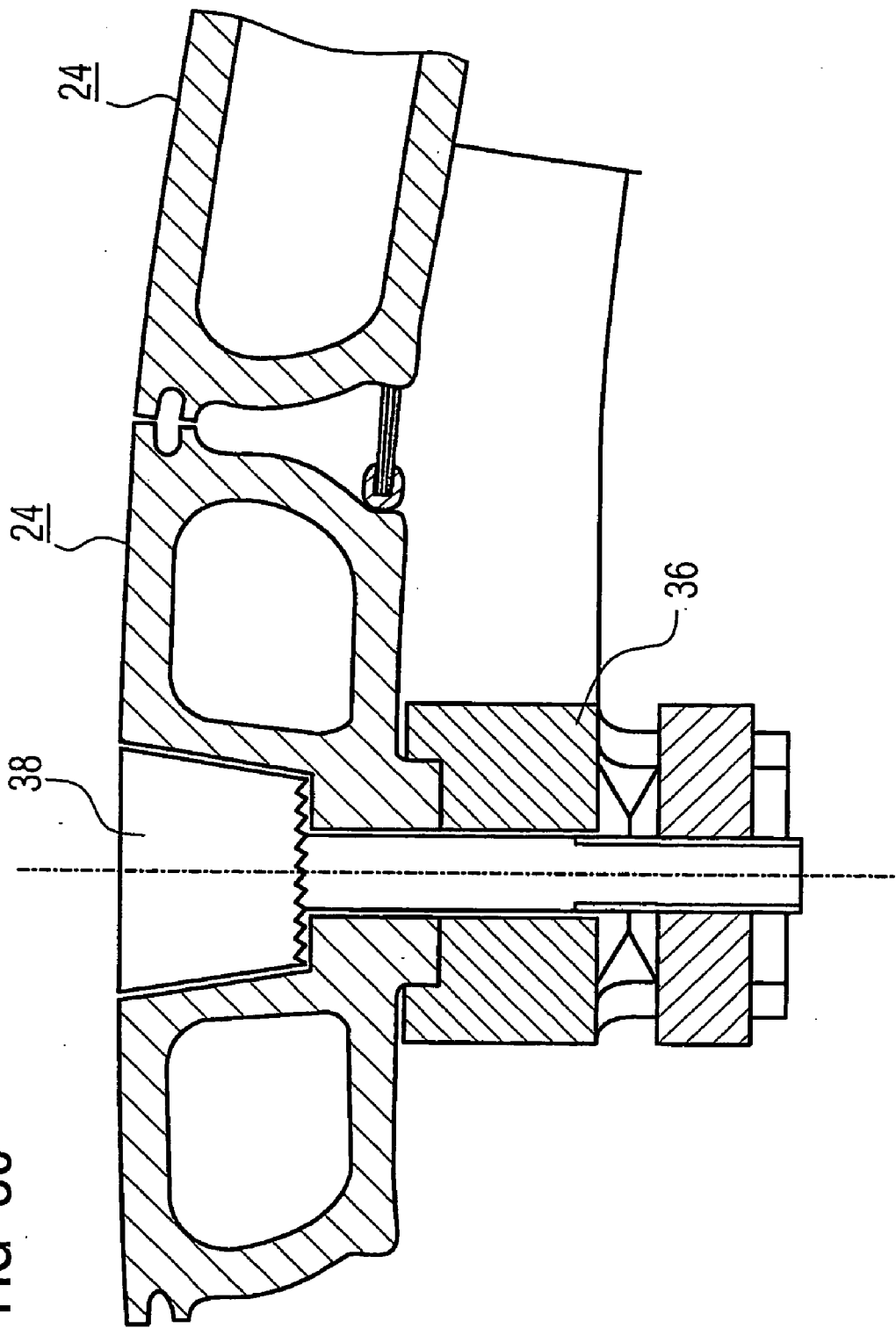

FIG 3b

FIG 3C



GAS TURBINE

CROSS REFERENCE TO RELATED APPLICATION

[0001] This application is the US National Stage of International Application No. PCT/EP2003/009703, filed Sep. 1, 2003 and claims the benefit thereof. The International Application claims the benefits of European Patent application No. 02020694.2 EP filed Sep. 13, 2002, both of the applications are incorporated by reference herein in their entirety.

FIELD OF THE INVENTION

[0002] The invention relates to a gas turbine having a combustion chamber in which a supplied fuel is brought into reaction with supplied combustion air to produce a working fluid.

BACKGROUND OF THE INVENTION

[0003] Gas turbines are used in many fields to drive generators or machines. In such applications the energy content of a fuel is used to generate a rotational movement of a turbine shaft. For this purpose the fuel is combusted in a number of burners, with compressed air being supplied by an air compressor. Combustion of the fuel produces a high-temperature working fluid which is subject to high pressure. This working fluid is fed into a turbine unit connected downstream from the relevant burner, where it expands in a manner that provides work output. In this arrangement a separate combustion chamber can be assigned to each burner, the working fluid flowing out of the combustion chambers being combinable before or in the turbine unit. Alternatively, however, the gas turbine can also be designed as what is known as an annular combustor type, in which most if not all of the burners open out into a common, typically annular, combustion chamber.

[0004] In the design of gas turbines of this kind a particularly high level of efficiency is normally one of the design objectives in addition to the achievable performance. Here, increased efficiency can basically be achieved for thermodynamic reasons by increasing the temperature at which the working fluid flows out of the combustion chamber and into the turbine unit. For this reason temperatures of around 1200 to 1500° C. are aimed at and also attained for gas turbines of this kind.

[0005] With the working fluid reaching such high temperatures, however, the components and parts exposed to this medium are subject to high thermal stresses. In order nonetheless to ensure a comparatively long useful life for the affected components, it is usually necessary to provide a means of cooling the components in question, in particular the combustion chamber. In order to prevent thermal deformation of the material which limits the useful life of the components, efforts are usually made to achieve as uniform a cooling of the components as possible, cooling air generally being used as the coolant. In this arrangement the cooling air is usually fed to the exterior of the inner wall of the combustion chamber via a cooling system consisting of tubes and partitions.

[0006] However, a cooling system constructed in this manner has the disadvantage that the design of the combustion chamber and cooling system is very complex. In par-

ticular, the actual combustion chamber wall is assigned a separate cooling system on its exterior which in turn has to be mounted from the outside. The process of producing a combustion chamber of this kind can therefore be very cost- and labor-intensive, as a large number of individual parts and joining processes are necessary for manufacture. This additionally results in increased fault proneness in the manufacture and operation of the gas turbine. Maintenance and repairs are likewise rendered more difficult by the complicated construction of the combustion chamber wall.

SUMMARY OF THE INVENTION

[0007] The object of the invention is therefore to specify a gas turbine having a particular high efficiency while being of simple design.

[0008] This object is achieved according to the invention by the wall of the combustion chamber being formed of coolant tubes.

[0009] The invention is based on the consideration that the gas turbine must be suitably designed to ensure a particularly high efficiency for particularly high media temperatures. In order to minimize fault proneness, particularly reliable cooling of the thermally stressed components, including the combustion chamber in particular, must be ensured. This can be achieved with comparatively little complexity by, on the one hand, making the combustion chamber wall itself coolable, and, on the other hand, constructing it from shaped parts that are kept comparatively simple and flexible. These two aspects of the combustion chamber embodiment can be adhered to by constructing the surrounding wall of the combustion chamber or the combustion chamber wall in a suitable manner from tubes, cooling air being specifically provided as coolant which, after passing through the coolant tubes, can be supplied to the combustion chamber as additional combustion air that has been preheated as a result of combustion chamber cooling.

[0010] In order to ensure particularly high strength of the combustion chamber wall, the coolant tubes are advantageously made of cast material, i.e. in other words each constituting a casting. A further advantage of this material selection is that reliable heat insulation can be provided in a particularly simple manner by suitably coating the cast material with a ceramic protective layer.

[0011] In order to keep the coolant tubes particularly immune to thermal stresses and therefore particularly robust, these are advantageously implemented with a trapezoidal cross-section. This cross-sectional shape exhibits a particularly high thermal elasticity resulting in only slight thermal stresses between cold and warmer areas of the tube even in the event of markedly differential heating of individual circumferential segments of the relevant tube, thereby achieving a long service life of the coolant tubes.

[0012] To form the combustion chamber wall and therefore also the actual combustion chamber, the coolant tubes are expediently mounted on support rings oriented in the circumferential direction of the combustion chamber. Through their position and form, these support rings dictate the shape of the combustion chamber annulus to be implemented by the coolant tubes, thereby enabling a mechanically stable combustion chamber structure to be produced in

the manner of a self-supporting structure using only a small number of further components in addition to the actual tubes.

[0013] The coolant tubes are expediently mounted on the support rings via cooled screws, the mounting of the coolant tubes via screws allowing individual or even a plurality of coolant tubes to be installed or dismantled in a particularly time-saving manner from the hot gas side while maintaining high strength, i.e. without having to disassemble the combustion chamber.

[0014] To ensure particularly high combustion chamber strength, the support rings are advantageously interconnected by a number of longitudinal fins in addition to the actual coolant tubes. The longitudinal fins and the support rings mounted perpendicular to them together form a supporting structure having a high degree of rigidity and strength. To provide a supporting structure of particularly high stability, the support rings and longitudinal fins are preferably welded together so that the rings and fins form a welded support frame.

[0015] A particularly high degree of flexibility in the shaping of the combustion chamber, allowing in particular flow conditions in the working fluid to be taken into account even in the combustion chamber while at the same time enabling a sufficient length and shape of the coolant tubes to be ensured, can be achieved in that the coolant tubes expediently consist of two or more tube segments interconnected in their longitudinal direction. The advantage of tube segmentation can be specifically that manufacturing difficulties in producing cast iron coolant tubes of sufficient length and appropriate shape are avoided.

[0016] In order to interconnect two consecutive segments of a coolant tube, each segment preferably has an assigned adapter piece or fitting on its relevant end, the adapter pieces being expediently designed for easy interconnectability particularly in respect of their shaping. In a further advantageous embodiment, the adapter pieces are specifically selected such that segments can be interconnected by means of a plug and socket connection. If the coolant tube cross-section is trapezoidal, the cross-section of the adapter piece is expediently selected such that it changes to a circular cross-section as it approaches the joint or the relevant tube segment end. A circular end cross-section of this kind allows particularly easy machinability for precision-fit connection to the next tube segment.

[0017] In order to ensure effective cooling of the coolant tubes forming the combustion chamber wall, these are advantageously impingement-cooled in an inlet area for the coolant. For this purpose, holes through which the coolant can flow are drilled in the outside of the coolant tubes. The coolant can therefore impinge on the inside of the tube and ensure a particularly intensive cooling effect in this area through intimate contact with the tube material. In the adjacent region, the coolant flows through the tubes in the longitudinal direction, cooling them by contact.

[0018] This cooling system has the advantage, on the one hand, that it is incorporated in the design of the combustion chamber wall and therefore only a small number of additional parts are required for constructing the cooling system. On the other hand, only a small coolant pressure loss occurs precisely due to the comparatively straight-line outflow of

the coolant. The advantage of this is that it facilitates a high degree of turbine efficiency even on the coolant side.

[0019] To ensure a particularly high overall efficiency of the gas turbine, the heat input to the coolant is advantageously recovered for the actual energy conversion process in the gas turbine. For this purpose the cooling air used as coolant and which has been heated during the cooling process is advantageously injected into the combustion chamber, the pre-heated cooling air being able to be used as the only combustion air or as additional combustion air.

[0020] In order to feed the outflowing coolant to the combustion process in the combustion chamber for this purpose, each coolant tube is preferably connected on the output side to a collecting chamber which for its part is disposed upstream of the combustion chamber on the air side. Via this chamber, the coolant can be mixed with the remaining compressor mass flow by a throttling device and fed to the combustion process.

[0021] Compensation of the flow conditions is achievable to an particular degree by assigning a collecting chamber of this kind to each burner, the design basis being such that the same quantity of cooling air or coolant is fed to each collecting chamber. To this end each burner is preferably assigned a collecting chamber, each connecting chamber being connected to the same number of coolant tubes. The particular advantage of this arrangement is that each burner is fed approximately the same amount of returned cooling air. Just by implementing the combustion chamber as an annular combustor ensures that a particularly homogenous combustion process is thereby produced in the combustion chamber.

[0022] The advantages achieved with the invention are specifically that particularly reliable combustion chamber cooling of simple design is made possible by implementing the combustion chamber wall as a plurality of interconnected coolant tubes provided for the through-flow of coolant, specifically cooling air. The integration of the coolant tubes in a self-supporting combustion chamber structure, in particular by means of the support rings, allows comparatively easy interchangeability of even individual maintenance-requiring tubes, a simple means of replacing combustion chamber structures in existing gas turbines also being provided, however, because of the flexibility achievable via the tubular design. Moreover, the tubular combustion chamber structure is comparatively stable and immune to vibrations of the combustion chamber wall, as the coolant tubes lend rigidity and strength to the annulus. The basic flexibility in terms of shaping and component selection achieved by constructing the combustion chamber wall from tube elements additionally enables probes or monitoring sensors for monitoring and/or diagnostics of the actual combustion process in the combustion chamber to be mounted, particularly by selectively using specifically modified tubes which allow, for example, suitable probes to be fed through from the outside to the inside of the combustion chamber.

BRIEF DESCRIPTION OF THE DRAWINGS

[0023] An exemplary embodiment of the invention is now explained in greater detail with reference to the accompanying drawings in which:

[0024] FIG. 1 shows a half-section through a gas turbine,

[0025] FIG. 2 shows in longitudinal section a segment of the combustion chamber of the gas turbine according to FIG. 1, and

[0026] FIG. 3a to c each show in cross-section a detail of the combustion chamber wall according to FIG. 2.

[0027] The same parts are denoted by the same reference characters in all the Figures.

DETAILED DESCRIPTION OF THE INVENTION

[0028] The gas turbine 1 according to FIG. 1 has a compressor 2 for combustion air, a combustion chamber 4 as well as a turbine 6 for driving the compressor and a generator (not shown) or a machine. For this purpose the turbine 6 and the compressor 2 are disposed on a common turbine shaft 8, also referred to as a turbine rotor, to which the generator or the driven machine are connected and which is pivotally mounted about its central axis 9.

[0029] The combustion chamber 4 implemented in the form of an annular combustor is equipped with a number of burners 10 for combusting a liquid or gaseous fuel. It is additionally provided with heat shield elements (not shown in greater detail) on its inner wall.

[0030] The turbine 6 has a number of rotating blades 12 connected to the turbine shaft 8. These rotor blades 12 are disposed in a ring shaped manner on the turbine shaft 8, thereby forming a number of rotor blade rows. The turbine 6 additionally comprises a number of fixed guide vanes 14 which are likewise mounted in a ring shaped manner on an inner casing 16 of the turbine 6, forming guide vane rows. The rotor blades 12 are used to drive the turbine shaft 8 by pulse transmission from the working fluid M flowing through the turbine 6, whereas the guide vanes 14 serve to direct the flow of the working fluid M between two consecutive rotor blades rows or rotor blade rings viewed in the direction of flow of the working fluid M, a consecutive pair from a ring of guide vanes 14 or guide vane row and from a ring of rotor blades 12 or rotor blade row also being referred to as a turbine stage.

[0031] Each guide vane 14 has a platform 18, also referred to as a blade root, which is disposed as a wall element for fixing the relevant guide vane 14 on the inner casing 16 of the turbine 6, said platform 18 being a comparatively heavily thermally stressed component forming the external boundary of a hot gas channel for the working fluid M flowing through the turbine 6. Each rotor blade 12 is similarly mounted on the turbine shaft 8 via a platform 20 also referred to as a blade root.

[0032] A guide ring 21 is disposed on the inner casing 16 of the turbine 6 between the spaced-apart platforms 18 of the rotor blades 14 of two adjacent rotor blade rows in each case, the outer surface of each guide ring 21 likewise being exposed to the hot working fluid M flowing through the turbine 6 and being separated from the outer end 22 of the opposite rotor blade 12 by a gap in the radial direction, the guide rings 21 disposed between adjacent rows of guide vanes being used in particular as cover elements which protect the inner wall 16 or other integral parts of the casing

from thermal overstressing by the hot working fluid M flowing through the turbine 6.

[0033] To achieve a comparatively high level of efficiency, the gas turbine 1 is designed for a comparatively high exit temperature of the working fluid M leaving the combustion chamber 4 of around 1200 to 1500° C. In order also to ensure a long lifetime or operating life of the gas turbine 1, its main components such as the combustion chamber 4 in particular are implemented in a coolable manner whereby, in order to ensure a reliable and sufficient supply of cooling air to the combustion chamber wall 23 of the combustion chamber 4 as coolant K, the combustion chamber wall 23 is of tubular construction comprising a plurality of coolant tubes 24 interconnected in a gas-tight manner to form said combustion chamber wall 23.

[0034] In the exemplary embodiment the combustion chamber 4 is designed as a so-called annular combustor, wherein a plurality of burners 10 arranged in the circumferential direction around the turbine shaft 8 open out into a common combustion chamber space. For this purpose the combustion chamber 4 is implemented in its totality as an annular structure which is positioned around the turbine shaft 8. To further clarify the embodiment of the combustion chamber wall 23, FIG. 2 shows in longitudinal section a segment of the combustion chamber 4 which continues in a toroidal manner around the turbine shaft 8 to form the combustion chamber 4.

[0035] As shown in the diagram according to FIG. 2, the combustion chamber 4 has an initial or inflow section into which the outlet of the respective assigned burner 10 opens at the end. Viewed in the direction of flow of the working fluid M, the cross-section of the combustion chamber 4 then narrows, with account being taken of the resulting flow profile of the working fluid M in this area. On the outlet side, the combustion chamber 4 exhibits in its longitudinal cross-section a curvature which favors the outward flow of the working fluid M from the combustion chamber 4 resulting in a particularly high pulse and energy transmission to the following first row of rotor blades seen from the flow side.

[0036] As shown in the diagram according to FIG. 2, the combustion chamber wall 23 is formed, both in the external area of the combustion chamber 4 and in its inner area, from coolant tubes 24 which are oriented with their longitudinal axis essentially parallel to the flow direction of the working fluid M inside the combustion chamber 4, the coolant tubes 24 being made of cast material which has been suitably selected specifically with regard to a particularly high mechanical and thermal strength of said coolant tubes.

[0037] In order to provide particularly high flexibility in the shaping of the combustion chamber 4 formed from the coolant tubes 24 to suit the required flow conditions of the working fluid M, in the exemplary embodiment each coolant tube 24 is constituted by a suitable combination of a plurality of consecutive tube segments 26, the type and number of said tube segments 26 being selected in such a way that, on the one hand, a particularly high mechanical strength of each individual tube segment 26 is ensured with regard to the length and shaping of each tube segment 26 and with regard to the cast material used, the shaping on the other hand being suitably selected in each case taking into account the required flow path for the working fluid M. The comparatively sharp local curvature possibly required can be pro-

vided in a particularly simple and reliable manner by the segmentation of the coolant tubes 24.

[0038] The coolant tubes 24 are additionally designed to be particularly strong specifically with regard to locally varying thermal loading and the resulting thermal stresses. For this purpose, the coolant tubes 24 and in particular the tube segments 26 forming them are of essentially trapezoidal cross-section, as shown for the central piece of a tube segment 26 in FIG. 3a, the coolant tubes 24 having a comparatively longer inner side 28 and a comparatively shorter outer side 30 in cross-section to form the toroidal, intrinsically curved structure of the combustion chamber 4. To seal the interspaces between adjacent coolant tubes 24, a suitable seal, e.g. a brush seal 32, is provided so as to produce a gas-tight and enclosed combustion chamber 4 by means of a suitable combination of coolant tubes 24.

[0039] The trapezoidal embodiment of the tube cross-sections favors in particular an intrinsically planar embodiment of the structure obtainable by joining together adjacent coolant tubes 24, so that the enclosed implementation of the combustion chamber 4 can be achieved in a comparatively simple manner.

[0040] For the segmented construction of the coolant tubes 24, the connection of two consecutive tube segments 26 of each coolant tube 24 on the coolant side has been kept particularly simple, particularly with regard to assembly and maintenance purposes. To achieve this, consecutive tube segments 26 of a coolant tube 24 are interconnected via an assigned adapter piece 34. To facilitate assembly of consecutive tube segments 26, each tube segment 26 is of essentially circular cross-section in its end areas to form the relevant adapter piece 34, as shown in FIG. 3b. By producing the coolant tubes 24 from cast material, the shaping of the relevant adapter piece 34 to suit the relevant tube segment 26 is possible in a comparatively simple manner, there being provided in the adapter area a continuous transition from the actually trapezoidal cross-section of the relevant tube segment 26 to the circular cross-section provided at the end. As shown in FIG. 2, the relevant adapter pieces 34 are displaced into the outer area of the combustion chamber 4 with respect to their central line and in comparison to the central pieces of the relevant tube segments 26, so that an essentially continuous smooth surface can be provided using suitable seal strips or plates in the inner walls of the combustion chamber 4.

[0041] To form the combustion chamber 4 as an integral, self-supporting structure, the coolant tubes 24 are mounted on a plurality of common support rings 36 which enclose the combustion chamber 4 formed from the actual coolant tubes 24 at a suitably selected spacing viewed in the longitudinal direction or in the flow direction of the working fluid M. The relevant coolant tubes 24 or the tube segments 26 forming them are mounted on the support rings 36 via coolable screws 38, as shown in the embodiment according to FIG. 3c. For further stiffening and mechanical fixing of the self-supporting structure forming the combustion chamber 4, the support rings 36 are interconnected by longitudinal fins essentially oriented in the longitudinal direction or in the flow direction of the working fluid M.

[0042] The tubular design of the combustion chamber 4 means that a comparatively large amount of cooling air can be applied to the combustion chamber wall 23 as coolant K

with only comparatively low pressure losses. In order enable the heating of the coolant K flowing through the coolant tubes 24 for cooling the combustion chamber wall 23 to be used for the actual combustion process in a manner promoting thermodynamic efficiency, provision is made for the coolant K issuing from the coolant tubes 24 to be injected into the combustion chamber 4 as the sole or additional combustion air. For this purpose provision is made for supplying the coolant K to the coolant tubes 24 at their ends assigned to the outlet of the combustion chamber 4, where the coolant K is supplied to the coolant tubes 24 via suitable inflow ports 42, as shown in FIG. 2, said inflow ports 42 being positioned in respect of their spatial orientation in such a way that impingement cooling of the relevant tube segment 26 initially takes place in the outlet area of the combustion chamber 4 by means of the cooling air flowing in as coolant K. Deflection of the coolant K then takes place inside the relevant tube segment 26, and the coolant K then flows through the relevant coolant tube 24 in its longitudinal direction, cooling taking place through contact of the coolant K with the relevant tube walls.

[0043] In the manner of a counter-flow to the actual working medium M, the coolant K therefore flows inside the coolant tubes 24 from the outlet area of the combustion chamber 4 to its inflow area in which the relevant burner 10 is also disposed. In this area the coolant K now heated or pre-heated by the continuous cooling of the relevant coolant tube 24 flows out of the coolant tubes 24 and is then assigned to a subordinate collecting chamber 46. The coolant tubes 24 are connected via said collecting chamber 46 to the assigned burner 10 on the output side so that the coolant K flowing out of the coolant tubes 24 can be used as combustion air in the relevant burner 10. Depending on the design of the gas turbine 1, the feeding of the relevant burner 10 with combustion air can be provided exclusively via the coolant K flowing out of the coolant tubes 24 or also using in some cases additionally required further combustion air supplied from an external source.

[0044] By the very embodiment of the combustion chamber 4 as an annular combustor, a maximally symmetrical arrangement of the burners 10 and consequently a maximally symmetrical adjustment of the flow conditions within the combustion chamber 4 is ordinarily advantageous. For the gas turbine 1, this basic principle is also taken into account on the coolant side, specifically in that the same number of coolant tubes 24 is assigned to each burner 10 on the combustion air side.

1-9. (canceled)

10. A gas turbine, comprising:

a combustion chamber having a combustion chamber wall; and

coolant tubes forming the combustion chamber wall,

wherein each coolant tube is comprised of a plurality of tube segments with consecutive tube segments of a coolant tube being interconnected via an assigned adapter piece and the adapter pieces are implemented so that the tube segments can be connected by a plug and socket connection.

11. The gas turbine according to claim 10, wherein the coolant tubes are made of cast material.

12. The gas turbine according to claim 10, wherein the coolant tubes have a trapezoidal cross-section.

13. The gas turbine according to claim 12, wherein the cross-section of the adapter pieces transition to a circular cross-section near a relevant joint.

14. The gas turbine according to claim 10, wherein the coolant tubes are mounted on a plurality of common support rings.

15. The gas turbine according to claim 14, wherein the coolant tubes are mounted on the support rings via coolable screws.

16. The gas turbine according to claim 14, wherein the support rings are interconnected by a plurality of longitudinal fins to form a supporting structure.

17. The gas turbine according to claim 10, wherein each coolant tube is connected on an output side to a collecting chamber through which an outflowing coolant is fed to a burner.

18. The gas turbine according to claim 17, wherein each burner is assigned a collecting chamber and each collecting chamber is connected to the same number of coolant tubes.

19. A gas turbine combustion chamber, comprising:

a combustion chamber wall; and

coolant tubes forming the combustion chamber wall,

wherein each coolant tube is comprised of a plurality of tube segments with consecutive tube segments of a coolant tube being interconnected via an assigned adapter piece and the adapter pieces are implemented so that the tube segments can be connected by a plug and socket connection.

20. The gas turbine combustion chamber according to claim 19, wherein the coolant tubes are mounted on a plurality of common support rings.

21. The gas turbine combustion chamber according to claim 19, wherein the coolant tubes are mounted on the support rings via coolable screws.

22. The gas turbine combustion chamber according to claim 19, wherein the support rings are interconnected by a plurality of longitudinal fins to form a supporting structure.

* * * * *