



(19) **United States**

(12) **Patent Application Publication**

Dolan et al.

(10) **Pub. No.: US 2017/0148550 A1**

(43) **Pub. Date: May 25, 2017**

(54) **CONTINUOUS COATING APPARATUS FOR ELECTROCERAMIC COATING OF CABLE**

H01B 7/02 (2006.01)

H01B 13/08 (2006.01)

(71) Applicant: **Henkel AG & Co. KGaA**, Duesseldorf (DE)

(52) **U.S. Cl.**

CPC *H01B 13/16* (2013.01); *H01B 13/0891* (2013.01); *H01B 1/023* (2013.01); *H01B 7/02* (2013.01)

(72) Inventors: **Shawn E. Dolan**, Sterling Heights, MI (US); **Mark W. Ziehm**, Oakland Township, MI (US); **Eric C. Kuhns**, Clinton Township, MI (US); **Michael Lombardo, JR.**, Harrison Township, MI (US)

(57) **ABSTRACT**

A system and a process for continuously electrolytically coating a wire, useful for a high tension cable, is provided. The system includes a bath containing a precursor for an electro-ceramic coating on a wire and containing a cathodic connection, at least one motor connected to at least one motive assembly to impart movement to the wire. A power source provides high voltage and high current to the wire through the electrification device, and through the wire in the bath to the cathode connection via the aqueous electrolytic solution. The process includes electrifying bare wire with a high voltage and a high current, passing the electrified bare wire through a bath having a cathodic connection and containing an aqueous solution with a precursor for an electro-ceramic coating, and electrochemically reacting the wire with the precursor thereby generating a coated wire having an electro-ceramic coating on at least one surface.

(21) Appl. No.: **15/425,523**

(22) Filed: **Feb. 6, 2017**

Related U.S. Application Data

(63) Continuation of application No. PCT/US2015/044283, filed on Aug. 7, 2015.

(60) Provisional application No. 62/034,358, filed on Aug. 7, 2014, provisional application No. 62/034,308, filed on Aug. 7, 2014.

Publication Classification

(51) **Int. Cl.**

H01B 13/16 (2006.01)

H01B 1/02 (2006.01)

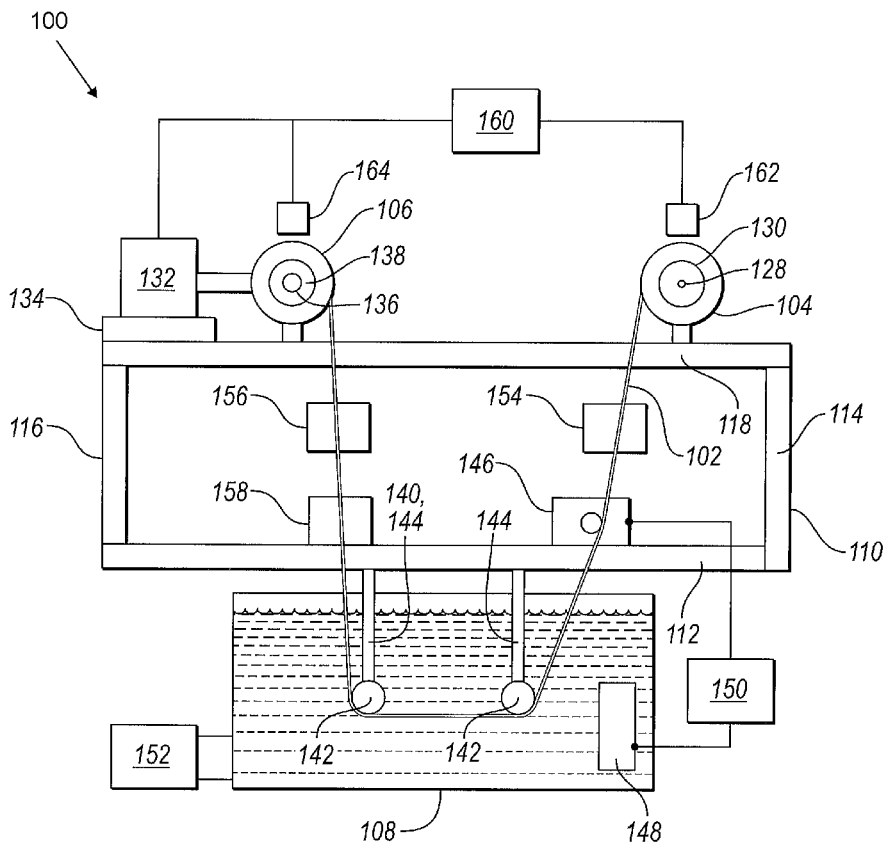

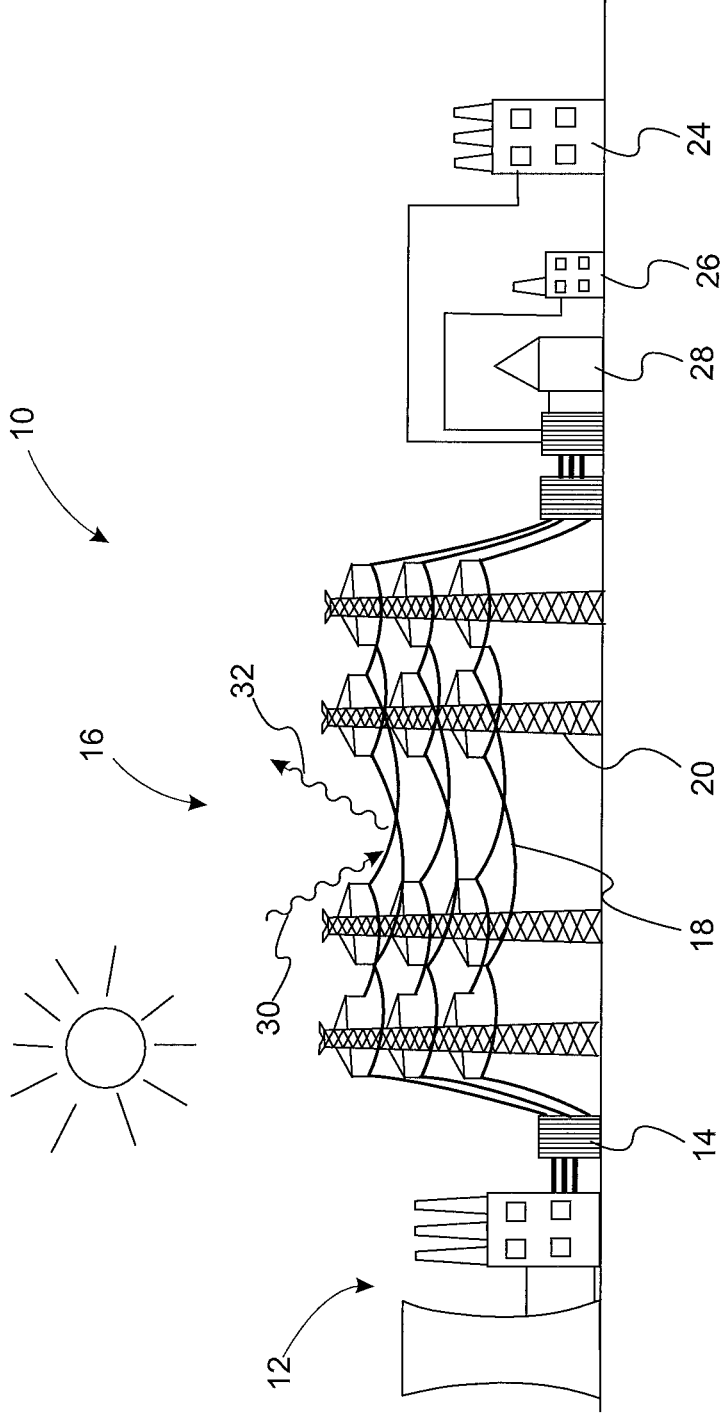

FIG. 1

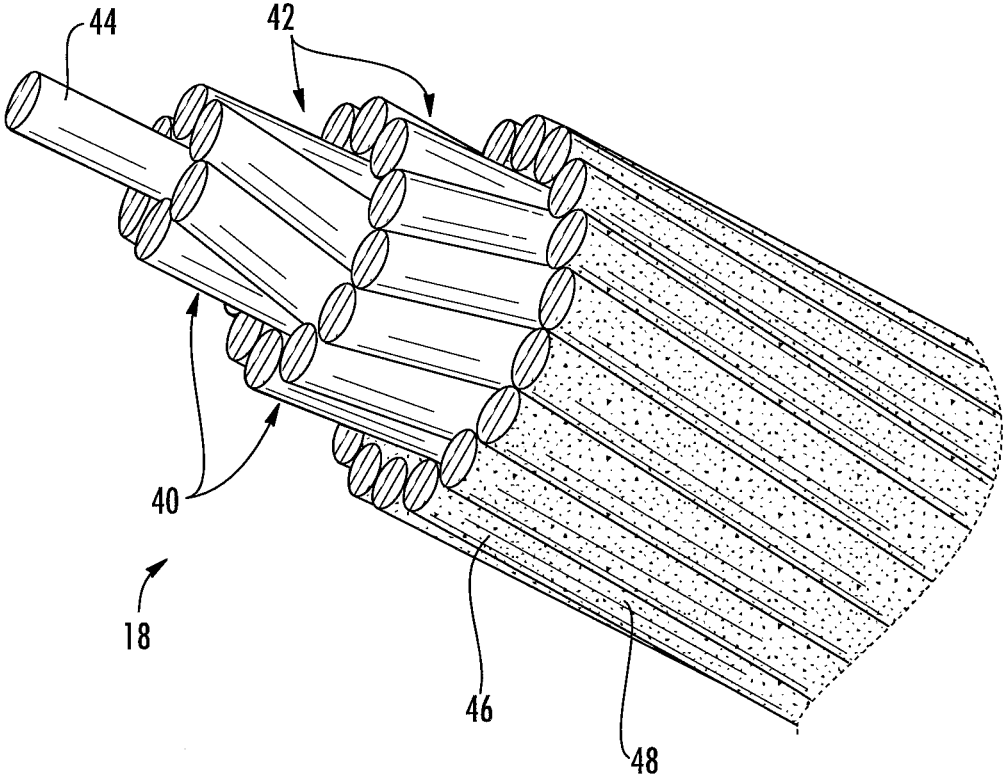

FIG. 2

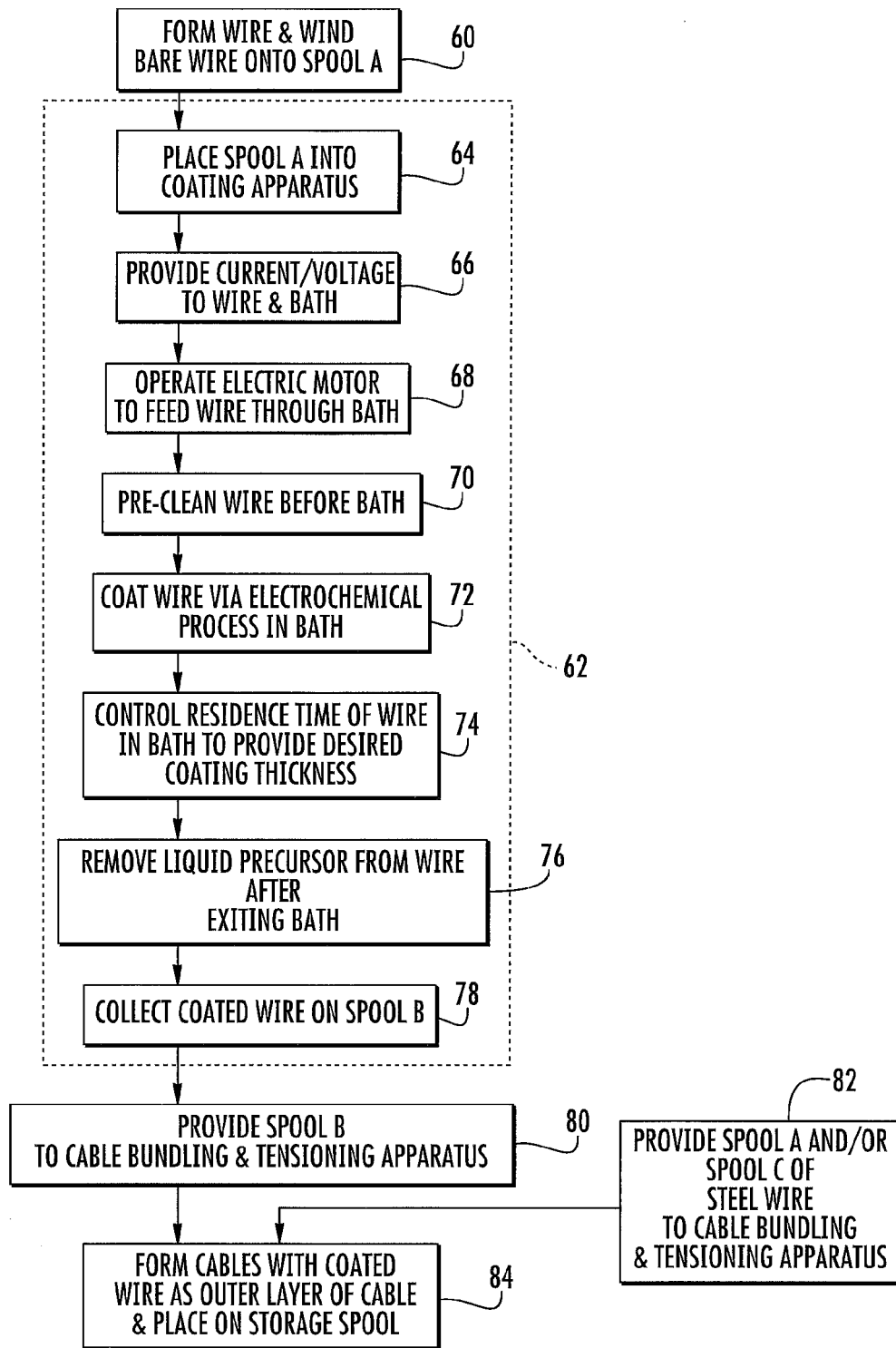

FIG. 3

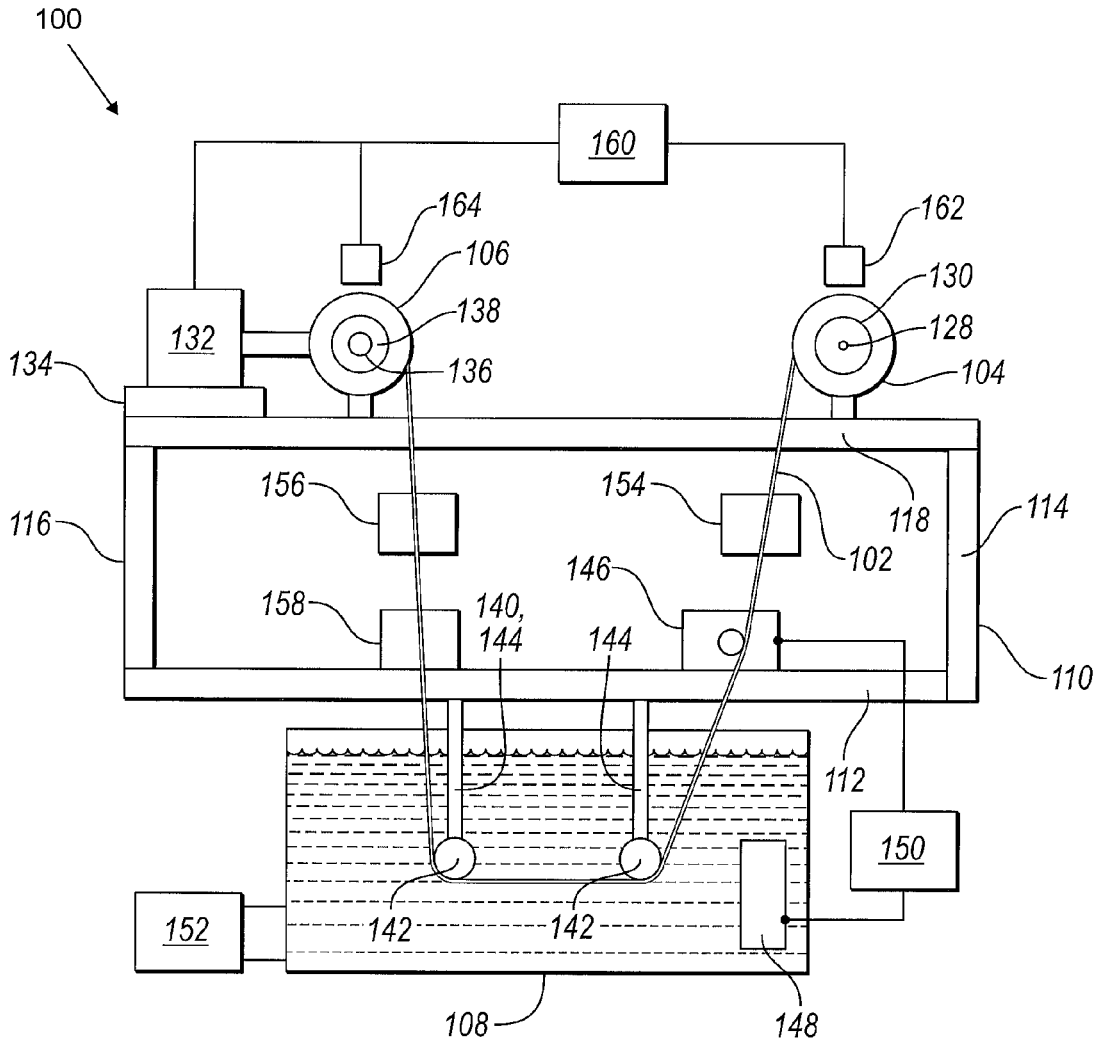

FIG. 4

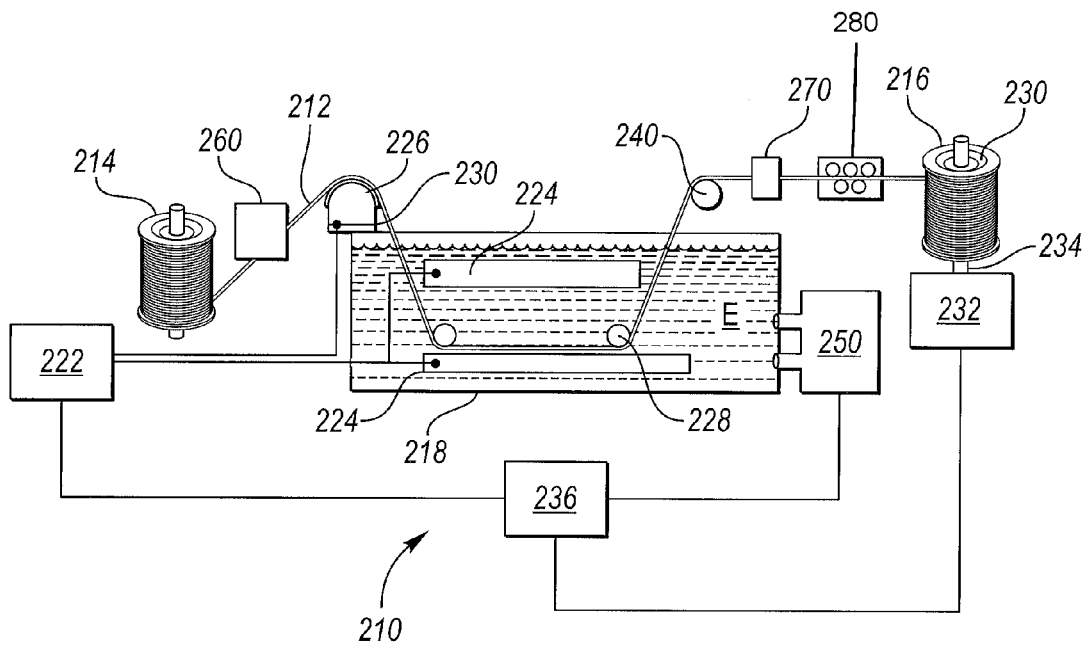

FIG. 5

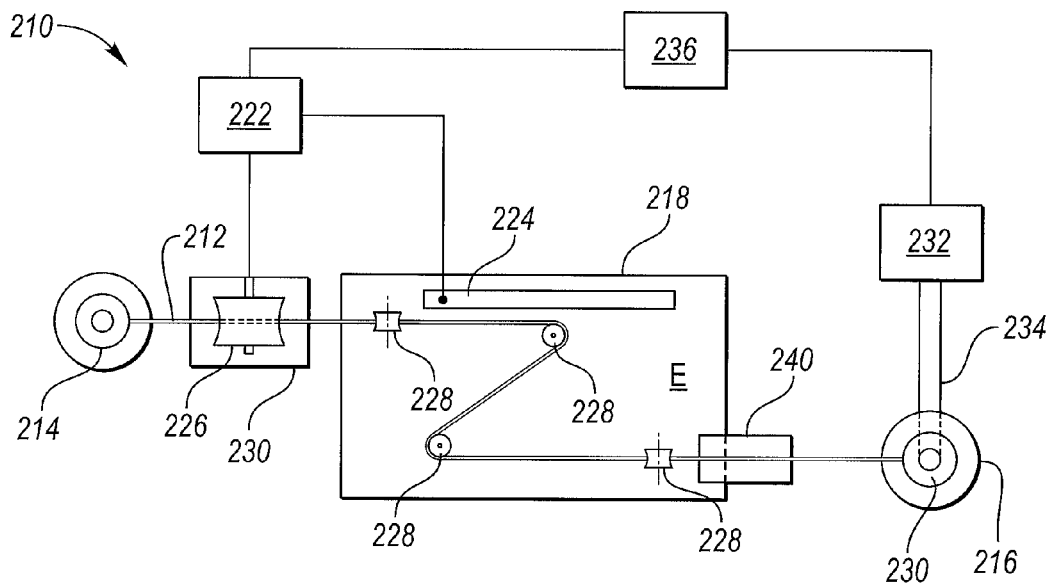

FIG. 6

CONTINUOUS COATING APPARATUS FOR ELECTROCERAMIC COATING OF CABLE

CROSS-REFERENCE TO RELATED APPLICATIONS

[0001] This application claims the benefit of U.S. provisional application Ser. No. 62/034,358 filed Aug. 7, 2014 and U.S. provisional application Ser. No. 62/034,308 filed Aug. 7, 2014, the disclosures of which are hereby incorporated in their entirety by reference herein.

TECHNICAL FIELD

[0002] Various embodiments relate to an apparatus and a process for coating wires, as well as wires coated thereby, useful in high tension cables and assembling the cables.

BACKGROUND

[0003] Power transmission and utility distribution systems for electricity include overhead cables carrying electricity at high tension voltage, e.g. greater than 100 kV, etc. in alternating current (AC) or direct current (DC), for distribution and transmission. Each cable is a bundle of multiple wires. A cable is two or more wires running side by side and bonded, twisted, or braided together to form a single assembly. These conductive wires are often made from or include elemental aluminum metal and/or an aluminum alloy. Desirable performance requirements for cables for overhead power transmission applications include corrosion resistance, environmental endurance (e.g., UV and moisture), resistance to loss of strength at elevated temperatures, creep resistance, as well as relatively high elastic modulus, low density, low coefficient of thermal expansion, high electrical conductivity and high strength.

[0004] The aluminum transmission cables are often bare or uncoated, act as conductors of electricity that tend to operate at a high temperature, for example, approximately 60-160 degrees Celsius, and generally have poor emissivity. These features are a drawback in conductors since resistivity of conductors generally increases with increasing temperature. The hot aluminum cable has phonon vibrations that in turn cause additional Joule heating or resistive heating. Emissivity (ϵ) is the ability of a surface to emit radiation energy compared to a black body at the same temperature and is expressed as a ratio of the radiation emitted by the surface to that emitted by the black body (scale is 0 to 1, with lower numbers indicating poorer emissivity and numbers approaching 1 indicating good emissivity). The emissivity of conventional uncoated aluminum wire and cable in use is generally in the range of about 0.05-0.10. Thus there is a need for aluminum conductor wire having improved emissivity and a need for methods of making these wires.

[0005] Users of overhead utility transmission cable, e.g. power companies and public utilities, experience large energy losses caused by the cable as the operating temperature of the cable increases because resistivity of conductors generally increases with increasing temperature. This energy loss is estimated to account for billions in expenses annually through loss of generated power as it moves through electrical supply lines, also known as "the grid". For example, a typical electrically loaded cable operates under load at a temperature starting from external environmental temperature (e.g. -65 degrees Celsius to about +50 degrees Celsius) and increases up to about 180 degrees Celsius. The conven-

tional uncoated aluminum overhead utility transmission cables have energy losses through excessive Joule heating as the cable operating temperature increases. The Joule heating losses from an uncoated cable may exceed 25% of the power generated, depending on grid size. Additionally, as the temperature of aluminum cable increases, the cable also sags downward with the force of gravity which may cause a hazard. This sag phenomenon requires increasing strength of the cable, generally by including heavy steel wire in the cable's core, and the use of heavy hardware and towers to hold the cable and secure it at a safe distance to eliminate issues relating to grounding and electrically shorting out the cable. Although overhead power transmission cables including aluminum wires are known, for some applications there is a continuing desire, for example, for more desirable sag properties.

[0006] Conventional bare cable has been previously coated using other coatings such as paints, etc., see for example WO2014025420, and cathodic plating of a dissimilar metal layer onto a metal wire; however, these coatings were limited in flexibility and long term adhesion on the cable such that the coating had a low durability. Thus a need remains for durable, high emissivity coatings on wire and cable, and methods and apparatus for manufacturing the coated wire and cable.

SUMMARY

[0007] The apparatus and process for electro-ceramic coating provides for continuous coating of a wire for use in high tension cable. The electrification device in the apparatus, such as a rotating electrical connector, e.g. an electrical slip ring, brushed or brushless, or a liquid mercury rotary contact; or a non-rotating dry anode connection, e.g. an aluminum or copper contact surface; provides the wire with a high voltage and a high current within a bath of liquid precursor, which in turn causes an electrochemical reaction with the surface of the wire within the bath to form the coating.

[0008] As used herein "high voltage" used in the coating apparatus and process includes peak voltage potential of at least about 140 volts up to about 800 volts; "high current" as used herein includes effective current of at least about 20 amps and up to about 1000 amps per wire. These values may be varied while practicing the continuous coating process within power applied ranges of at least 10, 20, 30, 40 or 50 kW per wire. Greater kW may be applied to a wire provided the wire has great enough cross-sectional area to withstand the added kW without damage to the wire.

[0009] In one embodiment, the coating comprises aluminum, titanium, oxygen and phosphorus. In another embodiment, the coating comprises aluminum, titanium, zirconium, oxygen and, optionally phosphorus.

[0010] Any frame supporting and guiding the wire through the bath may be made of an electrically insulating material to reduce overall energy use by the apparatus and to prevent arcing. The motor driving the wire through the bath may also be insulated to protect the motor from the electrified wire.

[0011] Various embodiments of the present disclosure have associated, non-limiting advantages. For example, the electro-ceramic coating on the outer strands or wires of the cable provides for increased emissivity of the cable and lower cable operating temperatures. By lowering the cable operating temperature, the losses from the cable incurred by Joule heating are reduced, and the cable sag is reduced. Also,

by operating the cable at a lower temperature, the cable is able to transmit the same amount of electrical power as an uncoated cable more efficiently, or greater amounts of electrical power at the same operating temperature as the uncoated cable.

[0012] Other than in the operating examples, or where otherwise indicated, all numbers expressing quantities of ingredients, reaction conditions, or defining ingredient parameters used herein are to be understood as modified in all instances by the term "about". Throughout the description, unless expressly stated to the contrary: percent, "parts of", and ratio values are by weight or mass; the description of a group or class of materials as suitable or preferred for a given purpose in connection with the invention implies that mixtures of any two or more of the members of the group or class are equally suitable or preferred; description of constituents in chemical terms refers to the constituents at the time of addition to any combination specified in the description or of generation in situ within the composition by chemical reaction(s) between one or more newly added constituents and one or more constituents already present in the composition when the other constituents are added; specification of constituents in ionic form additionally implies the presence of sufficient counterions to produce electrical neutrality for the composition as a whole and for any substance added to the composition; any counterions thus implicitly specified preferably are selected from among other constituents explicitly specified in ionic form, to the extent possible; otherwise, such counterions may be freely selected, except for avoiding counterions that act adversely to an object of the invention; molecular weight (MW) is weight average molecular weight; the word "mole" means "gram mole", and the word itself and all of its grammatical variations may be used for any chemical species defined by all of the types and numbers of atoms present in it, irrespective of whether the species is ionic, neutral, unstable, hypothetical or in fact a stable neutral substance with well-defined molecules; and the terms "solution", "soluble", and the like are to be understood as including not only true equilibrium solutions but also dispersions that show no visually detectable tendency toward phase separation over a period of observation of at least 100, or preferably at least 1000, hours during which the material is mechanically undisturbed and the temperature of the material is maintained at ambient room temperatures (18 to 25° Celsius). The chemical precursors used for forming the high emissivity coating are preferably free of the following chemicals: chromium, cyanide, nitrite ions, oxalates; carbonates; silicon, e.g. siloxanes, organosiloxanes, silanes, silicate; hydroxylamines, sodium and sulfur. Specifically, it is increasingly preferred in the order given, independently for each preferably minimized component listed below, that precursor for the electro-ceramic coating according to the invention, when directly contacted with metal in a process according to this invention, contain no more than 1.0, 0.35, 0.10, 0.08, 0.04, 0.02, 0.01, 0.001, or 0.0002 percent of each of the following constituents: chromium, cyanide, nitrite ions; oxalates; carbonates; silicon, e.g. siloxanes, organosiloxanes, silanes, silicate; hydroxylamines, sodium and sulfur.

BRIEF DESCRIPTION OF THE DRAWINGS

[0013] FIG. 1 illustrates a schematic showing a cable according to an embodiment in use;

[0014] FIG. 2 illustrates a cutaway view of a section of a cable according to an embodiment;

[0015] FIG. 3 illustrates a flow chart for one embodiment of a process of assembling a cable and coating a wire;

[0016] FIG. 4 illustrates a schematic of an apparatus for coating a wire according to an embodiment;

[0017] FIG. 5 illustrates a schematic of a system or apparatus for coating a wire according to another embodiment; and

[0018] FIG. 6 illustrates a schematic of a system or apparatus for coating a wire according to yet another embodiment.

DETAILED DESCRIPTION

[0019] As required, detailed embodiments of the present invention are disclosed herein; however, it is to be understood that the disclosed embodiments are merely exemplary of the invention that may be embodied in various and alternative forms. The figures are not necessarily to scale; some features may be exaggerated or minimized to show details of particular components. Therefore, specific structural and functional details disclosed herein are not to be interpreted as limiting, but merely as a representative basis for teaching one skilled in the art to variously employ the present invention.

[0020] FIG. 1 illustrates a schematic of an electrical system 10 from generation to point of use. Electricity is generated at a power station, such as a coal-fired plant, a nuclear plant, a hydroelectric plant or the like. Electricity is conducted from the plant 12 and typically may be directed to a step-up transformer 14. The step-up transformer 14 increases the voltage of the electricity. A power transmission system 16 is electrically connected to the transformer 14 and includes high tension cables 18. An example of a cable 18 produced according to the invention is illustrated in FIG. 2. The power transmission system 16 of FIG. 1 may include both transmission apparatus and devices for distribution of electricity in the power grid and operates at various high tension voltages, i.e. 100 kV, 800 kV, etc. The cables 18 are supported to keep them above the ground, generally by towers 20. The cables 18 are bundles of conductive wire, such as aluminum, and according to an embodiment, are coated with an emissive material such as a ceramic material, and may have an emissivity in the range of 0.5 to 0.9. Conventional cables are bare or uncoated such that the bare metal surface of the cable is directly exposed to the environment, and air is used as the insulating material. The conventional cables have a low emissivity, on the order of 0.05 to 0.10.

[0021] The power transmission system 16 is connected to one or more step down transformers 22 that lower the voltage of the electricity for use in heavy and light industry 24, 26, commercial, and residential destinations 28.

[0022] Generally, energy losses are incurred as the operating temperature of the cable 18 in the system 16 increases. Using conventional cables, the losses in the system 16 and grid may be measured in billions of U.S. dollars. Also, as the operating temperature of the cable increases, the cable may sag or droop, which may cause a hazard. The conventional cable needs to be strengthened, and towers 20 and connecting hardware for the cables are used to hold the cable and secure it at a safe distance to reduce or eliminate issues relating to grounding and shorting out the cable.

[0023] As the coated cable **18** is exposed to solar insolation, or incident solar radiation **30**, energy is transferred to the cable **18**. The cable is also generating an amount of heat based on phonon vibrations and Joule heating. By increasing the emissivity of the cable, the heat lost from the cable via radiation heat transfer and emission **32** is increased, thereby lowering the overall operating temperature of the coated cable **18** compared to an uncoated cable. The coated cable then maintains a lower temperature under amp loading (current) as well as provides black body radiation to remove heat from the surface of the wire more effectively than a wire that is lower in emissivity or a bare wire. A conventional uncoated cable operates under electrical load at a temperature up to approximately 180 degrees Celsius. A coated cable **18** may operate at the same electrical loading at a temperature up to 30% lower. This allows for the coated cable **18** to either have reduced energy losses or an increase in the ampacity that a cable is able to withstand.

[0024] An example of a cable **18** is illustrated in FIG. 2. The cable **18** includes wires or strands **40**. There are multiple layers **42** of wires **40** in the cable **18**. All of the wires **40** in the cable may be made of aluminum, an aluminum alloy, or another suitable lightweight conductive material. In an alternative embodiment, as shown, a portion of the wires **40** in the cable, such as central wires **44**, may be made of a support material, such as steel, to provide additional strength to the cable. Although the wires **40** are shown as having a circular cross-section, other cross sections may be used as are known in the art, including trapezoidal, and the like. The cable **18** may contain wires **40** having a common diameter, or may contain wires of varying diameters. Any number of layers **42** may be used with the cable **18** including more or less layers than shown in FIG. 2. The cable **18** may or may not contain steel or strengthening wires **44**, and the wires **44** may be located in the central region as shown, or otherwise distributed throughout the cable in one or more layers, and may be in a mixed layer of containing both steel and aluminum wires.

[0025] In the example shown in FIG. 2, the wires **40** in the outer layer **46** are coated with the electro-ceramic coating **48** or another suitable coating. The coating **48** is in direct contact with the underlying bare aluminum or aluminum alloy wire and is also exposed to environment. In other embodiments, the inner aluminum wires **40** may also be coated. The coating **48** has a higher emissivity than the metal of the outer layer wires **46**, such as aluminum, and may be a different color. In one embodiment, the emissivity of an electroceramic coated cable according to the invention may be at least 0.4, 0.5, 0.6, 0.7 or greater, which is at least ten times greater in emissivity compared to bare aluminum.

[0026] By coating outer layer wires **46** in the cable **18**, the emissivity of the cable is increased. Also, the surface area of the wires and cable is increased. A wire having electro-ceramic coating deposited thereon may have a specific surface area that is 10 times to 250 times the specific surface area of the uncoated wire, based upon BET measurement according to ASTM C1274-12. A specific surface area is the total surface area per unit mass (m^2/g). The increased surface area provides for increased radiative emission from the cable, as well as improved convective cooling. According to one example, the electro-ceramic coating increases the specific surface area of a wire by one to two orders of magnitude, i.e. ten times to one hundred times. Desirably, the increase in surface area is at least a factor of 10, 20, 30,

40, 50, 60, 70, 80, 90, 100, 120, 130, 140, 150 or 200 times that of the uncoated wire, and in one example the increase in surface area is in the range of 100 to 1000 times that of the uncoated wire. In some embodiments, the surface area is less than 1000, 700, 500, 400, 350, 300, 250, or 225 times greater than the surface area of the underlying coated wire, e.g. than that of a bare wire. A wire having electro-ceramic coating deposited thereon may have a surface area that is about 10, 20, 30, 40, 50, 60, 70, 80, 90, 100, 120, 130, 140, 150, 170, or 200 times greater than the surface area of the underlying coated wire and less than 1000, 700, 500, 400, 350, 300, 250, or 225 times greater than the surface area of the underlying coated wire. In one example, the specific surface area is 700 times that of the specific surface area of the uncoated wire. In a further example, the specific surface area was 140-700 times that of the specific surface area of the uncoated wire, based on BET measurement, and has an add-on mass of $800 \text{ mg}/\text{m}^2$.

[0027] The coating causes the cable to have a lower temperature than a conventional energized cable where both are operating under the same electrical load at a temperature up to about 150-180 degrees Celsius, e.g. approximately 160 degrees Celsius. The coated cable may show temperatures of 20, 30, 40, 50, 60, 70, 80 or 100 degrees Celsius lower in temperature than a similar cable having no coating. The electro-ceramic coated cable can operate up to 10%, 20% or 30% or more lower in temperature than the uncoated cable based on the same load, and desirably operates at temperatures lower than the uncoated cable of at least 1, 3, 5, 7 or 9%. This can provide the benefit of allowing either reduced energy losses from the coated cable, or the ability to increase the current carrying capability of a given cable for a given temperature.

[0028] It is desirable that the aluminum or aluminum alloy wire used in the cable **18** be continuously coated with an electro-ceramic or other high emissivity UV stable coating. The coating may be applied on wires which will form at least one or more of the most exterior set of wires (outer wires) surrounding a center core of wires (core wires) or may be applied to an already assembled cable comprising one or more layers of wire, e.g. outer wires, outer core wires, inner core wires and a center wire.

[0029] The coating may be applied during a continuous process to individual wires before the wires are bundled into the cable. "Continuous" and "continuously" as used herein are meant to include processes that do not involve batch coating, such as where all or more than 50% of a wire to be coated is in contact with the electrolyte at one time. By way of non-limiting example, a continuous wire coating process may include a process in which a feed wire to be coated is supplied to the electrolyte bath by passing the wire through the bath. In an example, a continuous process includes processes wherein the product intended to be coated, aluminum wire for example, is passed in a continuous manner into a bath of the electrolyte and the coated wire exits the electrolyte, preferably entry and egress of the wire from the bath may be at the same rate. The leading end of one wire may be attached to the trailing end of the wire ahead of it in the processing line. With the use of an accumulator, which may store up to perhaps 1000 ft. or more of wire ahead of the main section of the processing line, these wire ends can be joined without stopping the main section provided that adequate protection is provided against the current running through the electrolyte and the electrified wire. As a result,

the wire being processed through the coating bath need not stop and the process is truly "continuous." Continuous processes may include intermittent stoppages, by way of non-limiting example for changing of wire spools or maintenance, or be semi-continuous, i.e. continuous manufacturing, but for a discrete time period, without going outside of the scope of the invention.

[0030] Advantages of continuous coating of wire include integrated processing with fewer steps; little or no manual handling of the wire; increased safety; shorter processing times; increased efficiency; smaller coating baths and hence less energy consumption and facility space used; a more flexible operation with lower capital costs; smaller ecological footprint; on-line monitoring and control for increased product quality assurance in real-time; and a potential for reduced costs.

[0031] In one example, the outermost layer wires **46** in the cable **18** are coated prior to the bundling process to form the finished cable **18**. The outer layer wires **46** are singly coated and then placed as the outer wires on the cable **18**, thereby only coating the wires **40** that gain the most benefit from having a high emissivity coating on them, i.e. the wires exposed to the external environment. Alternatively, the entire cable may be coated after the bundling process. While, this aspect may provide only minor improvement in cable efficiency or operating temperature over cable with only the outer wires coated, having all aluminum surfaces of the cable that can be reached by the aqueous electrolyte coated can be useful in retrofit applications or where cable winding equipment is incompatible with the electro-ceramic coated wire. The greater emissivity coating may also allow for reduced sag of a finished cable of same design due to the reduced operating temperature.

[0032] High surface area coatings **48**, meaning those coatings with a unit surface area of more than five times that of the unit surface area of the underlying wire, that also have higher emissivity than the bare wire may be useful in cooling the wire by reducing the phonon vibrations thereby providing a reduction in overall Joule heating. This may effectively save on the order of tens of thousands of dollars in wasted electricity per installed mile of high tension cable per year. Alternatively, the coated cable may be used to transmit greater current levels than a conventional cable at the same operating temperature, thereby providing for increased power transmission and the ability to effectively increase the maximum power throughput of the cable and grid without introducing additional cable. The coatings are typically stable in ultraviolet (UV) light to withstand exposure to the sun. Additionally, the coatings may be scratch resistant, and may be able to bend with the cable **18** or outer layer wire **46** without cracking, delaminating or breaking. The coatings may be thin such that they do not significantly increase the overall weight of the cable. In one example, the coatings may be five to twenty microns in thickness, and may be in the range of ten to fifteen microns, five to ten microns, or eight to twelve microns in further examples.

[0033] For example, an electro-ceramic coating **48** may be applied to aluminum outer layer wire **46** that would normally be bare or uncoated on a high tension transmission cable **18** operating at approximately at 100-700 kV. Enhanced emissivity, enhanced surface area, UV stability, and good thermal conductivity are desirable characteristics for the coating **48**.

[0034] Note that wires having higher emissivity than bare wire with low solar absorption may be useful in many high tension electrical transmission application areas where voltage being transmitted is about 10 kVolts or more. By practicing the methods of the invention, the shade or color of the coating may be varied, for example, by various shades of grey ranging from white to black, with lighter shades of grey providing lower absorption of solar emissions. Darker shades of grey may be used to help the cable shed ice for example.

[0035] The coating **48** on the wire may be a uniform coating having a constant or generally constant thickness about the perimeter of the outer layer wire **46**. Desirably, this uniformity is achieved in the absence of a polishing, grinding or other removal of coating. In one embodiment, thickness may vary by 0 to 25%, for example at least 1, 3, 5, 7, 9 or 10%, and desirably no more than 25, 20, 18, 16, 14, or 12%, with higher tolerances being acceptable with thicker coatings. The coating **48** provides for improved emissivity, surface area and heat transfer compared to a bare wire. The coating **48** on the wire has been demonstrated to pass a T-bend test of OT-IT showing a high bend strength and high adhesion to the outer layer wire **46** to provide flexibility under weathering conditions and subjected forces during use. In one example, the emissivity of the coating ranges from about 0.5, 0.6 to 1.00, and in a further example, the emissivity is from 0.6 to 0.96.

[0036] In an alternative embodiment, knurling or rifling of the outer surface of the outer layer wires **46** may be also implemented before coating to further increase the surface area of the coating to improve heat transfer. In addition, secondary heat transfer fins such as spine fins, or fins that have a high surface area and are adhesively bonded auxiliary fin, may be adhesively bonded to the cable **18** or outer layer wire **46** for additional surface area enhancement. These secondary heat transfer fins may also be coated.

[0037] Various high emissivity coatings may be deposited using the methods and apparatus described in the present disclosure. An example of an electro-ceramic coating for use as the coating **48** and the associated chemistry, including reactants, to use when generating the coating on a light metal substrate such as aluminum or an aluminum alloy is described in U.S. Pat. No. 6,797,147 issued on Sep. 28, 2004; U.S. Pat. No. 6,916,414 issued on Jul. 12, 2005; and U.S. Pat. No. 7,578,921 issued on Aug. 25, 2009; the disclosures of which are incorporated in their entirety by reference herein.

[0038] FIG. 3 illustrates an exemplary flow chart for a process or method for manufacturing coated wire and a cable made therefrom according to one embodiment. In other embodiments, the process may include a greater or fewer number of steps, and various steps may be performed sequentially or in parallel with one another. The steps in the process may also be ordered differently from the illustrated flow chart in other embodiments.

[0039] Referring to FIG. 3, in step **60**, metal is formed into wire; this is an optional step in the process. Starting with a metal workpiece, an extrusion process, drawing process, or other metal-forming process may be used to generate a bare wire. The process may be cold or hot, based on the material used and the desired properties. In a typical wire generating process, a metal rod having a first diameter is drawn through a die thereby generating a wire having a second diameter less than the diameter of the metal rod. This step may be

repeated, drawing the wire rod through a series of dies, with or without spooling between dies, until the desired final diameter of the wire is achieved. The produced wire product is generally wound around a spool for ease of handling. The metal may be subjected to additional treatments, including tempering, annealing, and the like before, during and/or after the process by which the wire is generated from the metal workpiece. In one example, the wire may be aluminum or an aluminum alloy.

[0040] Alternatively, step 60 may comprise obtaining commercially available bare aluminum wire of desired geometry and providing same to the coating line.

[0041] In processes according to the invention, bare wire may be provided on a spool, reel or other wire carrier, which may be used to feed wire into the coating process. Desirably, the wire carrier for feeding the bare wire into the coating process comprises a spool, reel or the like about which the bare wire is wound. Bare wire will be understood by those of skill in the art to mean wire having surfaces of metallic aluminum or an aluminum alloy in the absence of a durable applied coating or sheathing, such as paint, insulation, conversion coatings and the like; bare wire may include some contaminants such as forming lubes, oils, soils and a thin alumina layer formed by environmental oxidation, as well as temporary treatments applied for transport to reduce damage to wire surfaces. Individual wires may have diameters ranging from about 0.05 inches up to not more than 0.375 inches. Suitable wire diameters for overhead conductor applications may be at least 1, 2, 3, 4 mm and not more than about 10, 9, 8, 7, 6, 5 mm. In one example, the bare wire has a diameter of 0.134 inches, although other wire diameters are also contemplated. Spool A in FIG. 3 is designated as a spool having bare wire wound thereon.

[0042] In one embodiment, the bare wire is coated using a coating sub-process for a wire, shown collectively as block 62. Processes according to the invention may include a greater or fewer number of steps, different variations of a step, and various steps in the process may also be ordered differently from the illustrated flow chart in other embodiments. For example, bare wire having only minor amounts of contaminants on the wire surfaces, may be coated in the absence of a pre-cleaning step or heavily contaminated wires may benefit from a pre-clean step with several sub-steps such as cleaning, pickling and rinsing.

[0043] In FIG. 3, at step 64, spool "A" containing bare wire is connected to, e.g. placed in, or on, the coating apparatus (as described further below with reference to FIGS. 4 and 5). The bare wire end is fed through the coating apparatus and connected to a spool B. Spool B is designated as a spool having coated wire thereon. A short section of wire on spool B may be uncoated based on the initial setup of the apparatus before operation, e.g. connection of the bare wire end to Spool B provides a short initial length of uncoated wire on Spool B. In other embodiments, the bare wire is fed directly into the coating apparatus from another process, such as a metal forming or other metal treatment process, and there is no feed spool, e.g. spool A, provided. Likewise, the coated wire may be directly fed into other processing stations after coating instead of onto a collecting spool. In one example, the coating apparatus is a sub-station in a cable winding operation and the coated cable, with or without drying, is fed into a cable forming step, or another process such that there is no collecting spool provided. The foregoing integrated processes may be used provided that

the current running through the coating solution and the electrified wire does not interfere with other operations and is not unfavorable from an economic or health and safety view. Alternatively, the coating process and apparatus may be operated independent of one or both of the wire generating operation and the cable forming operation.

[0044] At step 66, the wire in the apparatus is electrified to a high current and a high voltage, as described herein, using an electrification device such that the wire acts as an anode within the bath of a solution containing chemical precursors for the coating. A cathode is provided within the bath. Both the electrification device and the cathode are electrically connected to a power source, which when activated passes current to the wire via the electrification device, the electrical current passing from the anodic wire through solution to the cathode.

[0045] At step 68, a motor is operated to feed wire through the bath to coat the wire. The type of motor to be used is not particularly limited in any way, and can include for example an electric motor, an internal combustion engine, motors based on pneumatic or hydraulic power or the like. If only for economy, an electric motor is preferred. In one embodiment, speed of the wire is adjustable based on a feedback loop providing data on coating features, such as coating thickness measured, for example in real time or otherwise to a controller. In one embodiment, a user interface is provided for monitoring wire speed, motor parameters and allows making changes to same with adjustment and/or other devices associated with the apparatus.

[0046] At step 70, a cleaning device, such as a spray system, an acid or alkaline cleaning bath, ultrasound device, deoxidizing bath and/or an air knife, may be operated to clean the bare wire before it enters the solution in the coating bath. In one example, a spray system provides high pressure deionized water to clean the wire. The cleaning process can provide a better and more uniform substrate surface for coating deposition, and may also reduce introduction of debris or other contaminants into the coating bath.

[0047] At step 72, the wire proceeding through the bath is coated via an electrochemical process thereby providing a ceramic coating on the surface of the wire. In one embodiment, the solution in the bath is an aqueous solution containing a coating precursor comprising a source of titanium and a source of phosphorus. In one example, the aqueous solution contains H_2TiF_6 and a source of phosphorus. An electro-ceramic coating is deposited on the wire surface which comprises oxides of metals from the substrate and from the solution. In one embodiment, an oxide coating, which comprises aluminum oxide and titanium dioxide, is formed on the surface of the aluminum wire. Desirably, aluminum oxide is present in the coating in amounts of 1-25 wt. %, with the remainder comprising titanium dioxide and non-zero, small amounts of elements from the bath. In one example, the coating includes aluminum oxide in an amount of at least, 5 weight percent, 10 weight percent, 15 weight percent, 20 weight percent, or 25 weight percent, or 30 weight percent of the total weight of the high emissivity coating. In another refinement, high emissivity electro-ceramic coating includes aluminum oxide in an amount of at most, 80 weight percent, 75 weight percent, 70 weight percent, 60 weight percent, or 50 weight percent, or 40 weight percent of the total weight of the high emissivity coating. Typically, the metal oxide or oxides other than aluminum oxide are present in an amount of at least 20 10,

15, 20, 25, 30, 35, 40, 45, or 50 weight percent of the total weight of the high emissivity coating. In a variation, the aluminum oxide concentration varies over the thickness of the high emissivity coating being greater at the coating substrate interface and generally decreasing as with increasing distances away from the wire substrate. For example, the aluminum concentration may be 10 to 50 percent higher at 0.1 microns from the interface than at 3, 5, 7, or 10 microns from the interface.

[0048] In another embodiment, the emissivity of the coating is modified by changes in the identity of the electroceramic coating precursors in the electrolytic bath, e.g. precursor elements may include Ti, Zr, Zn, Hf, Sn, B, Al, Ge, Fe, Cu, Ce, Y, Bi, P, V, Nb, Mo, Mn, W and Co. In one embodiment, features of the coating are adjusted by changing aluminum and/or zirconium concentration of the aqueous solution. The inclusion of aluminum oxide and/or zirconium oxide advantageously allows the adjustment of coating features, e.g. the color and/or abrasion resistance of the high emissivity coating.

[0049] A visible glow or visible light discharge may occur along the surface of the wire as the coating is being formed. The electrochemical process may be a plasma process. The wire may provide an anode connection with oxygen radicals reacting with titanium anions at the surface of the wire to form a titanium oxide, such as titania. Protons at the cathode connection in the bath may lead to formation of hydrogen gas as water in the aqueous solution is electrolyzed, which desirably may be controlled and removed by one or more optional hoods or venting systems. In other examples, other chemical solutions may be used to provide a coated wire.

[0050] At step 74, a control system including a controller is used to control the speed of the motor, and the speed of the wire. By changing the speed of the wire, the residence time of the wire in the bath may be controlled, thereby together with other process parameters, controlling the thickness of the coating and the amount of dissolution of aluminum from the wire. Longer residence times for the wire may also be obtained by for example, defining a longer path through the bath. The thickness of the coating and/or the color of the coating may also be controlled by modifying the wave form and/or voltage utilized. The control system is also useful in adjusting spool speed for spools A and B. For wire provided on a spool, to maintain a constant speed of wire travel through the bath as the wire is taken off of spool A, the rotational speed of spool A may be increased to compensate for the smaller amount of wire provided by each rotation. Likewise, as the coated wire accumulates on spool B, to maintain the same feed velocity of the wire, the rotational speed of spool B may be decreased to compensate for the greater amount of wire accumulated during each rotation around the increasing circumference of spool B due to added coated wire. An accumulator, which may store up to perhaps 300 meters or more of wire ahead of the main section of the processing line, may be utilized to control wire speed and contact time in the bath. The control system may also control a cooling system connected to the bath to cool the solution and maintain the solution temperature within a predetermined range, desirably from ambient temperature, generally about 20 deg. Celsius to less than 100, 95, 90, 80, 70, 60, 50 or 40 deg. Celsius.

[0051] At step 76, after the wire leaves the bath any excess solution remaining on the coated wire may be removed and desirably the coated wire may be rinsed with water. In one

embodiment, the excess solution, with or without rinse water can be returned to the bath in a recycling process. At step 78, the coated wire is collected onto spool B. When spool A is empty or near empty, the coating process 62 is stopped and spool B containing coated wire is removed from the apparatus.

[0052] Although the coating process 62 is described for a single wire, multiple wires may be fed through the bath simultaneously, with each wire being electrified at a high power, as described herein. For simultaneously coating multiple wires, a minimum separation between the electrified wires should be maintained to avoid arcing and each wire may be provided with separate electrification devices and guides as well as supplied from and collected on separate spools. In alternative embodiments, a cable, e.g. a wound bundle of wires, may be fed through the bath such that the outer surface wires and at least portions of the interior wires of the cable are coated.

[0053] In one embodiment, the coated wires are polished after removal from the coating apparatus. The polishing step serves to reduce surface roughness and allows for easier handling of the coated wires during later bundling steps. The smoother surface is also less abrasive to uncoated inner wires of a cable, without significantly reducing surface area provided by the electrolytic coating.

[0054] At optional step 80, multiple spools of coated cable (spool B) are connected to a cable winding or forming apparatus. The cable is formed by bundling and tensioning the wires to provide a predetermined degree of twist to the various layers in the cable. The twist may be the same between various layers, may be twisted in opposed directions, or the degree of twist vary from layer to layer. In one example, all of the wires in the cable are coated.

[0055] In another embodiment, only some or a portion of wires in the cable are coated. At step 82, additional spools of uncoated or bare wire (spool A) may be provided to the cable forming apparatus. A spool of support wire, such as a steel wire, a composite wire, or the like, may also be provided to add additional mechanical strength, such as tensile strength or reduced sag characteristics, to the cable. The uncoated wires and the support wires are positioned to be internal wires within the cable. The coated wires are positioned to form the outer layer of the cable, or the layer that provides the outer perimeter of the cable such that the cable presents a coated outer surface to the environment. The cable is formed by bundling and tensioning the wires to provide a predetermined degree of twist to the various layers in the cable, as described above.

[0056] In one embodiment, secondary heat transfer fins such as spine fins, or other durable fins that have a high surface area are also coated according to the invention. These secondary heat transfer fins may be wound on a collecting spool, such as spool B and provided for application to the formed cable using an adhesive or the like, thereby multiplying the outer cable surface area and increasing emissivity.

[0057] At step 84, the cable is then provided onto a storage spool or reel. The cable may be installed onto towers such as shown in FIG. 1 with various connectors and hardware as appropriate. The cable for use in overhead power transmission is installed such that the coating on the cable is exposed to the environment, including solar radiation, or insolation. The cable for use in overhead power transmission does not have an insulation sleeve, e.g. a sheath of polymer surround-

ing wires or the cable, provided on the cable when in use based on the operating temperatures of the cable.

[0058] FIG. 4 shows a schematic of one embodiment of an apparatus 100 for continuously coating a wire or strand, for example for use in the cable 18 of FIGS. 1 and 2. Other configurations or layouts for the apparatus 100 are contemplated based on the scale of the system, etc. The apparatus 100 may also be used to directly coat a cable, such as cable 18, in a similar manner as to that described below for the wire or strand. In FIG. 4, a wire 102 runs from a first spool 104 to a second spool 106. Each spool 104, 106 has a central barrel, or center cylindrical section, and may have flanges extending therefrom on either end of the central barrel. The first spool 104 provides a supply of uncoated, bare wire, such as aluminum, useful for example in a high tension transmission cable, with the bare wire wound on the barrel of the spool 104. The second spool 106 receives the coated wire with the coated wire being wound on the barrel of the spool 106. In other embodiments, the wire may be continuously fed from and/or to another process such that there is not a first and/or second spool for the apparatus.

[0059] The wire 102 is fed through a bath 108 comprising a container at least partially filled with an aqueous solution comprising a precursor for a ceramic coating on the wire. The container for the bath 108 may be made from a material that is chemically unreactive with the solution. The container for the bath may be electrically conductive to provide a cathode, or may be made from electrically insulating and non-conductive material.

[0060] A first frame 110, or main frame, is supported above the bath 108. In one example, the first frame 110 has a lower sub-frame 112, and first and second end supports 114, 116. The frame 110 may be made from non-conductive materials, and in one example, the frame 110 is electrically conductive. Legs or other support members may support the frame 110 on an underlying surface and above the bath 108, as shown or in other configurations.

[0061] The first spool 104 is supported by the frame 110 or the first end support 114 by a stationary shaft 128 or spindle. The spool 104 may be removed from the shaft 128 as needed for operation of the apparatus. A fastener may connect with the end of the shaft 128 to retain the spool 104 on the shaft 128 and allow for removal. The shaft 128 is positioned to be generally perpendicular with a section of the wire 102 as it leaves the spool 104, with the wire leaving the spool generally tangentially according to one example. A bearing assembly 130 is provided between the spool 104 and the shaft 128. In one embodiment, the bearing assembly is within the cylindrical section of the spool 104 or on an outer section of the shaft 128 to reduce friction of the spool 104 as it rotates about the shaft 128.

[0062] In this embodiment, an electric motor 132 is provided, and in FIG. 4 is shown on the second end support 116. The electric motor may be an AC motor or DC motor. In other examples, the motor 132 may be another device, such as an internal combustion engine, a pneumatic or hydraulic motor, or the like. The electric motor has an output shaft 136, which may form at least a portion of a motive assembly to drive the wire. A pad 134 made from an electrically insulating material is positioned between the electric motor 132 and the frame 110 such that the electric motor 132 is electrically isolated from the frame 110. The pad 134 may also provide vibration damping. Electrically insulating material may also be positioned between the wire and the

shafts or spindles 128, 136. The shafts and spindles 128, 136 may also be made from or coated with an electrically insulating material. The container for the bath 108 may also be made from an electrically insulating material or include an electrically insulating layer. The electrically insulating material prevents conduction of the high voltage and high current.

[0063] The second spool 106 is supported by the output shaft 136 of the electric motor 132. The spool 106 may be removed from the shaft 136 as needed for operation of the apparatus. A fastener may connect with the end of the shaft 136 to retain the spool 106 on the shaft 136 and allow for removal. The motor 132 shaft and the inner diameter of the spool 106 may be keyed or splined such that they rotate together. A sleeve 138 made of electrically insulating material is positioned within the barrel of the spool 106 such that the electric motor 132 is electrically isolated from the spool 106. Alternatively, the spool 106 may be made from an electrically insulating material.

[0064] In alternative embodiments, the electric motor 132 may be connected to the first spool 104, or each spool 104, 106 may be provided with an electric motor to impart movement to the wire 102 through the bath 108. Alternatively, the wire 102 may be moved using guides that are driven by one or more motors.

[0065] A second frame 140, or drop frame, is supported by the main frame 110 and extends away from the main frame 110 such that it may be received within the bath 108. In other examples, the main frame 140 and drop frame 140 are separate components in the system and are not connected to one another. In one example, as shown, the second frame 140 is connected to the lower sub-frame 112. The second frame 140 is positioned such that it is partially submerged within solution in the bath 108. The second frame 140 has at least one guide member 142 to guide the wire through the bath 108. In the example shown, the second frame 140 has first and second members 144 that extend from the first frame 110 with each frame member 144 having a guide member 142 connected to an end region. Each guide member 142 may be a wheel connected to the frame member 144 by a bearing connection, or may be a nonrotating guide member as is known in the art. Desirably, the frame members 144 are made from an electrically insulating material or an electrically non-conductive material such that electrical current does not pass from the bath 108 to the main frame 110. In one example, the frame members 144 or the frame 140 are made from plastic, such as a plastic or polymer, including, e.g. PVC, CPVC, polyethylene, polypropylene, polyamide, nylon, phenolic resin, as well as non-conductive composites. The frame 140 and guide members 142 are made from or coated with a material that is chemically inert or nonreactive with the solution in the bath. The frame 140 may be removable from the bath 108 for maintenance and other operating considerations.

[0066] In FIG. 4, an electrification device 146 is supported by the main frame 110. In other embodiments, the device 146 may be supported by the frame 140 adjacent to the bath 108. The electrification device 146 is positioned to contact the wire 102, preferably near the bath 108; in the Figure the electrification device is above the bath 108. The device 146 provides a dry anode connection to electrify the wire, and electrifies the entire length of the wire with a high voltage and a high current, as described herein. The electrified wire 102 electrochemically reacts with the solution in the bath

108 to form a coating on the wire which comprises metals from the wire as well as metals from the bath.

[0067] In one embodiment, the electrification device **146** may provide at least 10, 20, 30, 40 or 50 kW per wire and higher provided that the conductor has a great enough cross-sectional area to withstand the added kW without damage to the wire. Current density may be increased for purposes of heating the wire in the bath to temperatures such that the coating is applied and the wire is tempered in the same step in the bath. The electrification device may provide 50-60 kW to a single strand of wire in one example, and for a production system may provide 1, 2, 3, 4, 5, 6, 8, 10 or more MW of power across multiple strands of wire running simultaneously through the bath **108**. In a further embodiment, the device **146** is a rotary switch having a contact wheel that rotates with passage of the wire **102** as the wire is fed from spool **104** to spool **106**. The rotary switch of the device **146** may have a liquid mercury rotary contact, which is a rotating electrical connector with an electrical connection made through a pool of liquid metal which transfers the electricity to the contact, thereby providing a low resistance, stable connection. As the mercury contact rotates, the liquid metal maintains the electrical connection between the contacts without wear and with low resistance. The liquid mercury rotary contact is able to provide the high voltage and high current needed to electrify the wire **102**. According to one example, the high voltage is a peak voltage at or greater than 125 Volts.

[0068] High current is an effective current at or greater than about 20-1000 Amps per wire. As wire size increases so does current carrying capability without damage to the wire. Too much current through a wire may result in excessive heating of the wire, resulting in embrittlement of the wire. Depending upon the gage of wire to be coated the amperage may be adjusted to at least 20, 30, 40, 50, 60, 70, 80, 90, or 100 Amps and preferably not more than 1000, 400, 300, 200, 180, 160, 140, 120 Amps per wire, i.e. a single strand of wire, for high tension wire. Applied current may be alternating current, asymmetric alternating current, direct current, or pulsed direct current. In some examples, direct current is used and may be applied as an on/off waveform. In one embodiment, a total period of the waveform is at least 0.01, 0.1, 1 or 10 milliseconds and up to 50, 40, 30, 20 or 15 milliseconds. Waveforms may be adjusted to a ratio of at least: 0.1, 0.3, 0.6, 1.0, 1.2, 1.5, 1.7, 2.0, 2.2, 2.5, 2.8, 3.0, 5.0, 10.0, or up to an infinite ratio where the direct current is always on and there is no off portion, also referred to as straight DC.

[0069] In alternative embodiments, the electrification device **146** may comprise a rotating electrical connector, e.g. an electrical slip ring, brushed or brushless, or a liquid mercury rotary contact; or a non-rotating dry anode connection, e.g. an aluminum or copper contact surface, or other devices.

[0070] One or more cathode connections **148** are provided within the bath **108**. The cathode connection **148** may be the container for the bath **108** itself, if the container is electrically conductive; or a component of suitable material, such as metal or graphite, positioned within the bath and in contact with the solution.

[0071] The electrification device **146** and the cathode connection **148** are connected to a power supply **150**. The power supply **150** may be controlled to provide direct current and/or alternating current to the anode and cathode

or may provide asymmetric alternating current, for example, with 400-500 Volts peak voltage at the anode, 40-50 Volts at the cathode. In some embodiments, the power may be a square wave form pattern with a frequency of 0.01-40 milliseconds. In other examples, the power supply may provide direct current or pulsed direct current to the anode and cathode. Frequency may be adjusted from 25 Hz to 25,000 Hz, may be high frequency such as 200-25,000 Hz or 100-10,000 Hz. Waveforms may include sinusoidal, triangular, and/or rectangular in any of AC, DC or pulsed DC current, as well as complex waveforms containing superimposed waveforms, e.g. an AC waveform over a DC waveform.

[0072] A cooling system **152** is in fluid communication with the bath to maintain the temperature of the solution in the bath. In one example, the cooling system **152** maintains the solution at a predetermined temperature range by cooling the fluid. The temperature range may be greater than the freezing point and less than the boiling point of the solution provided that coating quality is not adversely affected. Generally useful ranges include zero to forty degrees Celsius, twenty to forty degrees Celsius, or other ranges as appropriate. As the wire is electrochemically coated, the solution is heated based on the reaction. The cooling system **152** includes a heat exchanger and may include a pump to circulate and cool the fluid. A fan or the like may be provided to direct air over the heat exchanger to cool the solution. In other embodiments, the solution contained within the bath **108** has sufficient thermal mass, or the electrochemical process does not release sufficient heat to require a cooling system **152**.

[0073] In one example, at least one cleaning device **154** may be positioned to interact with and clean the wire **102** before it enters the bath **108**. The cleaning device **154** may be supported by the frame **110**. The cleaning device **154** may be a cleaning bath that chemically removes contaminants or a physical cleaner which removes contaminants by physical impingement, e.g. abrasion, contacting with pressurized fluid, media blasting, burnishing, or polishing, upon the wire. The cleaning device **154** may be a spray system that sprays pressurized fluid across the wire as the wire is fed past the cleaning system to remove any debris or other undesirable material from the surface of the bare wire, such as cutting fluid, etc. The cleaning device **154** may also include a dip tank, and other cleaning systems as are known in the art for use with a continuous system. In other examples, the bare wire is sufficiently clean such that no cleaning device is needed for use with the apparatus **100**. In another example, a cleaning device **156** is positioned to interact with the wire **102** after it exits the bath **108**.

[0074] One or more sets of guides **158** may be provided on the first frame **110** or the second frame **140** to guide the wire **102** to travel along a predetermined path between the first spool **104** and the second spool **106**. The guides **158** may be roller guides, including one or two plane guides, or the like. The guides **158** may assist in directing the wire to pass by the cleaning device **154** and/or the air knife **156**. The guides **158** may assist in a smooth feed of the wire from the first spool **104**. The guides **158** may also present the wire at the appropriate angle to the second spool **106** for a smooth winding.

[0075] A controller **160** is in communication with the electric motor **132**. The controller **160** may be a single controller or multiple controllers in communication with one

another. The controller **160** may be connected to random access memory or another data storage system. In some embodiments, the controller **160** has a user interface. The controller **160** is configured to control the electric motor **132**, the power supply **150**, and the cooling system **152** for startup procedures, shut down procedures, and emergency stop procedures.

[0076] It is recognized that any circuit or other electrical device disclosed herein may include any number of micro-processors, integrated circuits, memory devices (e.g., FLASH, random access memory (RAM), read only memory (ROM), electrically programmable read only memory (EPROM), electrically erasable programmable read only memory (EEPROM), or other suitable variants thereof) and software which co-act with one another to perform operation (s) disclosed herein. In addition, any one or more of the electrical devices as disclosed herein may be configured to execute a computer-program that is embodied in a non-transitory computer readable medium that is programmed to perform any number of the functions as disclosed herein.

[0077] In one embodiment, the controller **160** is in communication with a first sensor **162** and a second sensor **164**. The first and second sensors **162**, **164** are used with the first and second spools **104**, **106**, respectively. The first sensor **162** may be a speed and/or position sensor to determine the rotational speed of the first spool **104** or the feed speed of the wire after it exits the spool **104**. The first sensor **162** may also include an optical sensor or the like to determine the amount of wire on the first spool **104**, for example, the outer diameter of the wire on the barrel of the spool **104**. The second sensor **164** may be a speed sensor for the electric motor **132** that senses the rotational speed of the motor shaft, and corresponding speed and/or position of the spool **106**. The second sensor **164** may also include an optical sensor or the like to determine the amount of wire on the second spool **106**, for example, the outer diameter of the coated wire on the barrel of the spool **106**.

[0078] The controller **160** controls the speed of the electric motor **132** to control the speed of the second spool **106** and the feed speed of the wire through the apparatus. By controlling the feed speed of the wire **102**, the residence time of the wire within the bath **108** is controlled. In one embodiment, the controller **160** controls the motor **132** speed to maintain a residence time, meaning the total time on contact with the solution of a given point on the wire, within a predetermined range or at a predetermined speed. Generally, residence time ranges from about 1, 2, 3, 4, 5, 6, 8, or 10 seconds and at least for efficiency is not more than 180, 160, 140, 120, 100, 60, 45, 30, 20 or 15 seconds. In one example, the residence time is approximately five to ten seconds. Generally, feed rate or wire speed is dependent upon achieving sufficient residence time for desired coating properties, e.g. thickness, surface area and emissivity, and desirably can range from about 10 feet per minute to about 200 feet per minute. Higher speeds may be used provided that residence time is maintained. As the amount of wire on the first spool **104** (and the diameter of the wrap of wire) decreases, the spool must spin faster to provide the same feed rate of wire through the bath. Likewise, as the amount of wire on the second spool **106** (and the diameter of the wrap of wire) increases, the spool **106** must spin slower to provide the same feed rate of wire through the bath. Therefore, the controller **160** uses a closed or open control loop to

constantly adjust and control the rotational speed of the electric motor **132** to maintain a generally constant feed rate of wire and residence time.

[0079] As the apparatus **100** is operated, bare wire leaves the spool **104** and travels over the electrification device **146** and is electrified with a high current and a high voltage, as described herein, via a dry anode connection. The wire may be an aluminum or aluminum alloy wire in an embodiment. The bare wire then enters the bath **108**. The wire is electrified during contact with the bath. In one example, the bath contains an aqueous electrolytic solution containing at least one of a complex fluoride and an oxyfluoride. In other examples, other solutions as disclosed herein may be used. The wire electrochemically reacts with the precursor in the bath by passing a current between the wire in the bath and a cathode in the bath to form the coating. This reaction may form a visible light-emitting discharge adjacent to the wire (or an oxygen plasma) and a hydrogen gas from the water in the aqueous solution. The electrified wire may form a plasma with the liquid precursor, with the bath acting as a cathode and the wire acting as an anode. A coating is formed on the bare wire, and the coating may be a metal/metalloid oxide electro-ceramic. The coating has an emissivity greater than that of the bare wire. The thickness of the coating is controlled via control of various parameters including but not limited to the residence time of the wire within the bath. The emissivity of the coating may also be adjusted by changing the temperature of the solution in the bath **108**, and/or the power provided by the electrification device **146** to a wire. In one embodiment, without changing the bath content, the emissivity can be increased by about 10, 20, 30, 40, or 50% by controlling deposition parameters including waveform, voltage, amperage, and contact time.

[0080] The continuous length of the wire **102** is electrified at a high current and voltage, and a cathode is present in the bath **108** such that the wire acts as an anode in the bath **108**. The first spool **104**, the frame **110**, and various guides or devices on the frame **110** may also be electrified. The second frame **140** is made of a non-conductive or insulating material to prevent arcing, formation of the coating on the frame, and to reduce electrical consumption by the apparatus. The electric motor **132** is also electrically insulated from the frame **110** and the wire **102** to prevent electrical shorting of the motor **132**.

[0081] The second spool of coated wire **102** may be removed from the apparatus **100** and used to form, for example a transmission or distribution cable. Multiple spools of coated wire may be combined or bundled to form a cable as shown in FIG. **2**. Additionally, bare wire and/or support wires may be added to the cable assembly. In one example, bare wires and support wires are internal wires in the cable, and the coated wires form the outer perimeter wires of the cable. The various wires of the cable may be tensioned to provide a predetermined degree of twist. The cable may be installed on a tower or in the electrical grid for use in transmitting voltage at least about 5 kV or more, and as such the outer coated surface of the cable formed by the coated wires interacts with the environment to cool the cable by emitting radiation, including radiation in the infrared wavelength.

[0082] FIGS. **5** and **6** are schematics of two exemplary embodiments of coating system **210**.

[0083] FIG. **5** is a side view schematic of a system **210**. FIG. **6** is a top view schematic of another system **210**.

Common reference numbers are used for similar components of the two schematics. The system 210 includes a feed spool 214 that contains uncoated wire, at least one coating bath container 218 which during operation contains an electrolyte composition E, and a take-up spool 216 that accepts coated wire. The wire 212 travels from spool 214 to spool 216 through the bath 218. The apparatus 210 may also be used to directly coat a cable, such as cable 18, in a similar manner as to that described below for the wire.

[0084] Coating system 210 also includes at least one electrical power supply 222 electrically connected to a cathode 224 located within coating bath container 218, and to an electrification device 226 (dry anode) which electrifies uncoated wire 212 such that the wire 212 acts as an anode in the electrolyte composition E, during operation.

[0085] Coating system 210 also includes at least one guide member 228 (two shown in FIG. 5 and four shown in FIG. 6) used to guide uncoated wire 212 through the electrolyte bath in container 218. Coating system 210 includes roller guides 240 used to guide coated wire 212 as it exits the electrolyte bath in container 218 and onto take-up spool 216. The roller guides may also function to remove electrolyte carried out of the bath on coated wire 212.

[0086] Coating system 210 includes at least one motive device 232 which moves the wire 212 through the coating system. The motive device 232 is not particularly limited as long as it causes the wire 212 to move through the coating system 210. The motive device 232 typically includes a motor and a motive assembly; suitable motive assemblies may comprise a combination of a motor shaft, rotating guides, tensioning rollers, accumulators and the like. In one embodiment, the motive device 232 may include an electric motor which moves the wire for example by rotating the take-up spool 216 via motor shaft 234 acting as a motive assembly, which may be the sole motive force for moving the wire 212 or may be supplemented by motors drawing the wire through the bath, for example by shoes or rotating guides propelling the wire along its path.

[0087] In some embodiments, as shown in FIG. 5, coating system 210 includes a cooling system 250 in fluid communication with the electrolyte E in bath container 218. The cooling system 250 may provide direct cooling to the electrolyte E or may include a heat exchanger system or the like.

[0088] Coating system 210 also includes a controller 236 which is configured to control at least one of the motive device 232, the power supply 222, and the cooling system 250. In operation, the power supply 222 supplies the electrification device 226 with a high voltage and current, as described herein, which is provided to wire 212 when it is in proximity to the electrification device 226, and generally in contact therewith. Wire 212 is unwound from the feed spool 214, contacts the electrification device 226, is electrified thereby and passes into the electrolyte E in bath container 218. Wire 212 passes through the electrolyte E for a residence time sufficient to electrolytically coat wire 212, then coated wire 212 exits the electrolyte E, moves past or through drip guides 240 and is wound onto take-up spool 216. Coated wire 212 may optionally pass through other stages before or after the electrolyte bath, for example a pre-cleaning bath 260, a post rinsing bath 270 which may include a post-coating drying station 280, as shown in FIG. 5. One important aspect of the invention is providing appropriate electrical insulation to parts of the coating system 232

which may be damaged by high voltage and current used for coating formation on the wire 212 or, for those parts of the system that do not require such high power, insulating or isolating them from the high power, at least for economy and safety. Hence, while feed spool 214, coating bath container 218, take-up spool 216 and various guides are in contact with the electrified wire 212 or electrolyte E, these parts may either be made of non-conductive materials or physically insulated from other parts of the coating system. For example, the electric motor portion of a motive device 232 may be insulated from the electrified wire by interposing non-conductive contact surfaces which impart movement to the wire 212, but do not conduct electricity back to the motor of the motive device. For example, electrically insulating material 230 may be used to isolate the wire 212. Desirably, at least motors, pumps and the controller are insulated or isolated such that they are not electrified by the high voltage and current supplied to the electrification device 226 and the wire 212.

[0089] FIG. 5 additionally illustrates that more than one cathode 224 may be used in the bath 218, and the cathodes may be positioned to affect coating properties, residence time, etc.

[0090] FIG. 6 additionally shows a complex path for the wire 212 through the solution E in the bath 218. The guides 228 direct the wire 212 through the bath 218 for a longer residence time.

[0091] Various embodiments of the present disclosure have associated, non-limiting advantages. For example, the electro-ceramic coating on the outer stands or wires of the cable provides for increased emissivity of the cable and lower cable operating temperatures. By lowering the cable operating temperature, the losses from the cable incurred by Joule heating are reduced, and the cable sag is reduced. Also, by operating the cable at a lower temperature, the cable is able to transmit the same amount of electrical power as an uncoated cable more efficiently, or greater amounts of electrical power at the same operating temperature as the uncoated cable. The apparatus and process for electro-ceramic coating provides for continuous coating of a wire for use with the cable. The electrification device of the coating apparatus, such as a rotating or non-rotating connector, provides the wire with a high voltage and a high current, as described herein. The electrified wire travels through a bath of liquid precursor, which in turn causes an electrochemical reaction with the surface of the wire within the bath to form the coating. The frame supporting and guiding the wire through the bath may be made of an electrically insulating material to reduce overall energy use by the apparatus and to prevent arcing. The electric motor driving the wire through the bath may also be insulated to protect the electric motor from the electrified wire.

[0092] While there have been described above the principles of this invention in connection with specific apparatus, it is to be clearly understood that this description is made only by way of example and not as a limitation to the scope of the invention.

[0093] Additionally, the process and systems in the various embodiments described herein may be extended for use in coating other wire and/or cable for various applications. The coating may also be adjusted using the process as described herein to modify the thickness, porosity, color, emissivity, and other properties based on the desired application for the wire and/or cable.

EXAMPLES

Example 1

[0094] An aluminum alloy sample was coated in an aqueous electrolytic deposition bath comprising 5.24 parts zirconium basic carbonate and 20.06 parts hexafluorozirconic acid, at constant temperature and 410 Volts peak for 3 minutes. A DC pulsed square waveform having an on/off ratio of 1:3 was used. The coated sample was removed from the bath, rinsed with water and allowed to dry. Emissivity of the sample was 0.68 at 3.1 microns thickness.

Example 2

[0095] An aluminum alloy sample was coated in an aqueous solution comprising 1 part hexafluorotitanic acid and 1 part hexafluorozirconic acid to 0.375 parts of a source of phosphate, measured as phosphate. The aqueous solution was energised to 450 volts applied at constant temperature for a time sufficient to deposit an electroceramic coating. A DC pulsed square waveform having an on/off ratio of 2.78 was used. The coated sample was removed from the bath, rinsed with water and allowed to dry. Emissivity of the sample was 0.79 at 9.0 microns.

Example 3

[0096] Aluminum alloy samples were coated in an electrolytic deposition bath comprising a phosphate source and hexafluorotitanic acid at constant concentration. All samples were coated in the same bath at constant temperature. Voltage, amperage, time and waveforms were varied, as shown below. Waveforms for pulsed DC current were square. The coated samples were removed from the bath, rinsed with water and allowed to dry. Emissivity of the samples was determined for various combinations of voltage, amperage, time and waveforms used, and the results are shown in the table below.

TABLE 1

Variation	Thickness (microns)	Waveform and on/off ratio	Volts	Amps	Time (sec)	Emissivity
1	1.41	DC on/off ratio 2.78	250	185	12	0.41
2	3.03	DC on/off ratio 2.78	290	185	12	0.52
3	3.23	DC on/off ratio 2.78	320	185	12	0.58
4	4.85	DC on/off ratio 2.78	370	185	12	0.6
5	6.32	DC on/off ratio 2.78	410	185	12	0.62
6	7.99	DC on/off ratio 2.78	475	185	12	0.62
7	8.13	DC on/off ratio 1.71	475	185	12	0.61
8	7	DC on/off ratio 1	390	185	12	0.59
9	6.75	DC on/off ratio 1	475	185	12	0.61
10	8.4	Straight DC	390	147	12	0.64
11	10.25	Straight DC	475	147	12	0.62
12	13.34	Two step AC	450	185	60	0.66
13	7.8	DC on/off ratio 2.78	475	25	60	0.62
14	5.35	DC on/off ratio 2.78	475	10	120	0.59

TABLE 1-continued

Variation	Thickness (microns)	Waveform and on/off ratio	Volts	Amps	Time (sec)	Emissivity
15	3.61	DC on/off ratio 2.78	320	185	20	0.56
16	5.74	DC on/off ratio 2.78	370	185	20	0.62
17	7.66	DC on/off ratio 2.78	410	185	20	0.62
18	10.85	DC on/off ratio 2.78	475	185	20	0.67
19	9.84	DC on/off ratio 1.71	475	185	20	0.65
20	6.24	DC on/off ratio 1	390	185	20	0.6
21	7.89	DC on/off ratio 1	475	185	20	0.62
22	7.03	Straight DC	390	147	20	0.63
23	11.18	Straight DC	475	147	20	0.68

[0097] The above results showed that without changing the bath content, the emissivity can be increased by about 40% from the lowest to the highest emissivity shown, by controlling deposition parameters including waveform, voltage, amperage, and contact time.

Example 4

[0098] An elemental depth profile was taken of the coatings of Example 3 using glow discharge optical emission spectroscopy (GDOES). Amounts of various elements were determined in weight percent at particular distances from the metal surface. For all samples, oxygen content built gradually from initial values of less than 2 wt. % at the substrate, while the Al content dropped precipitously over a span of about 2 microns independent of coating thickness. Surface analyte weight percentages were similar across the samples, as shown in the table below:

TABLE 2

Variation	Emissivity	Surface Al (wt. %)	Surface Ti (wt. %)	Surface O (wt. %)	Surface P (wt. %)
1	0.41	<10	~4	50-60	4-9
2	0.52	<10	~10	~74	4-9
3	0.58	<10	15-25	50-60	4-9
4	0.6	<10	15-25	50-60	4-9
5	0.62	<10	15-25	50-60	4-9
6	0.62	<10	15-25	50-60	4-9
7	0.61	<10	15-25	50-60	4-9
8	0.59	<10	15-25	50-60	4-9
9	0.61	<10	~28	50-60	4-9
10	0.64	<10	15-25	50-60	4-9
11	0.62	<10	15-25	50-60	4-9
12	0.66	<10	15-25	60-70	4-9
13	0.62	<10	15-25	60-70	4-9
14	0.59	10 < x < 15	15-25	50-60	4-9
15	0.56	<10	~4	60-70	4-9
16	0.62	<10	15-25	50-60	4-9
17	0.62	<10	15-25	50-60	4-9
18	0.67	<10	15-25	60-70	4-9
19	0.65	<10	15-25	60-70	4-9
20	0.6	<10	15-25	50-60	4-9
21	0.62	<10	15-25	60-70	4-9
22	0.63	<10	15-25	50-60	4-9
23	0.68	<10	15-25	60-70	4-9

[0099] Comparing the data from the GDOES analysis of the coatings of Example 3 showed surprising similarities

between elemental profiles despite different emissivity values. These results tend to show that coating thickness, waveform of deposition, voltage and amperage work synergistically to produce coatings, that although quite similar elementally, have differing emissivities.

Example 5

[0100] Aluminum alloy samples were coated in an electrolytic deposition bath comprising a phosphate source and hexafluorotitanic acid at constant concentration. All samples were coated in the same bath at constant temperature and voltage. Time and waveforms were varied, as shown below. Waveforms for pulsed DC current were square. The coated samples were removed from the bath, rinsed with water and allowed to dry. Emissivity of the samples was determined for various combinations and the results are shown in the table below.

TABLE 3

Variation	Thickness (microns)	Waveform and on/off ratio	Time (sec)	Emissivity
24	9.4	DC on/off ratio 2.78	30	0.70
25	10	Straight DC	30	0.71
26	9.4	DC on/off ratio 1	42	0.77

[0101] The above results showed that with bath content and voltage held constant, the emissivity was increased by about 10%, from the lowest to the highest emissivity shown, by controlling waveform and contact time.

Example 6

[0102] Sets of commercially available aluminum alloy wires and representative flat panel samples of the aluminum alloys were coated in electrolytic deposition baths comprising a phosphate source and hexafluorotitanic acid at constant concentration. Voltage, power, time and waveforms were varied, as shown below. Waveforms for pulsed DC current were square. The coated samples were removed from their baths, rinsed with water and allowed to dry. Quality and thickness of the coatings were assessed and the results are shown in the table below.

TABLE 4

Variation	Thickness (microns)	Measured feet/minute	Waveform on/off ratio	Volts	Avg. kW during run
27	7.3	10.0	1	450	30
28	6.6	34.0	1	450	32
29	8.9	22.7	2.78	450	39
30	8.3	26	2.78	450	42
31	8.2	31	2.78	475	62

[0103] The emissivity of the representative flat panel sample from the same set, selected to have sufficient flat surface area for taking emissivity readings, was measured. Emissivity of the flat samples was measured to be 0.73±0.03. The above results showed that with bath content held constant, the emissivity can be maintained at a given level by selecting and/or controlling waveform, voltage, power, and contact time (for wire this would generally be distance of travel per unit time through a bath along a path of constant dimension, aka line speed).

Example 7

[0104] A series of aluminum alloy samples were electrolytically coated at constant voltage of 435 V with a constant waveform having an on/off ratio of 2.78, using the electrolyte of Example 3 which had been modified by the addition of dissolved Al, in amounts as shown in the table below. The current applied and the coating time was held constant within each alloy group. The coated samples were removed from the electrolyte, rinsed with water and allowed to air dry. The samples in each alloy group were subjected to abrasion testing using a CS-10 grade abrasive wheel under 500 gram load. After 5000 cycles of testing the weight loss and TWI were determined. Average values for both values are shown below.

TABLE 5

Alloy	Average Weight Loss (mg)	Average TWI	Al added to the coating bath (ppm)
713	8.51	1.70	10
	14.66	2.93	450
	17.46	3.49	860
A356	9.70	1.94	10
	24.95	4.99	450
	27.65	5.53	860
A380	7.45	1.49	10
	17.65	3.53	450
	17.50	3.50	860
2024	14.10	2.82	10
	22.30	4.46	450
	24.20	4.84	860
6061	16.35	3.27	10
	32.60	6.52	450
	30.95	6.19	860
3003	19.00	3.80	10
	27.95	5.59	450
	27.60	5.52	860
5052	17.80	3.56	10
	30.75	6.15	450
	31.45	6.29	860

[0105] The above results show that adding Al to the electrolytic bath, changes coating features, e.g. the abrasion resistance and TWI of the resulting coating.

[0106] While exemplary embodiments are described above, it is not intended that these embodiments describe all possible forms of the invention. Rather, the words used in the specification are words of description rather than limitation, and it is understood that various changes may be made without departing from the spirit and scope of the invention. Additionally, the features of various implementing embodiments may be combined to form further embodiments of the invention.

What is claimed is:

1. A system for continuously electrolytically coating a wire for a high tension cable for use as an overhead transmission line, the system comprising components of:

- a bath for an aqueous electrolytic solution containing a precursor for an electro-ceramic coating on a wire;
- a first spool frame adapted to support a first spool for providing the wire to the bath;
- a second spool frame adapted to support a second spool for receiving the wire from the bath;
- an electrification device for electrifying the wire and located between the first spool frame and the bath;
- a plurality of guide members positioned to route the wire from the first spool to electrically engage with the

- electrification device, pass into, through and out of the bath, and be rewound around the second spool, wherein at least one of the plurality of guide members is a bath guide member removably fixed in position in the bath for routing the wire into contact with the aqueous electrolytic solution;
- at least one motor adapted to move the wire from the first spool, through the plurality of guide members and rewind the wire around the second spool;
- a cathodic connection positioned in the bath for contacting the aqueous electrolytic solution; and
- a power source electrically connected to the electrification device and the cathodic connection, said power source providing high voltage and high current to the wire through the electrification device, and through the wire in the bath to the cathode connection via the aqueous electrolytic solution;
- wherein the at least one motor is connected to at least one motive assembly capable of imparting movement from the motor to the wire.
2. The system of claim 1 wherein the electrification device is a dry anode connection providing at least 25 kW per wire.
 3. The system of claim 1 wherein the electrification device comprises at least one of a rotating electrical connector and a non-rotating connection for imparting the high voltage and high current to the wire.
 4. The system of claim 1 wherein the electrification device comprises at least one of an electrical slip ring, a liquid mercury rotary contact and a non-rotating electrically conductive contact surface.
 5. The system of claim 1 wherein the motive assembly comprises at least one of the first spool, the second spool, and one or more of the plurality of guide members.
 6. The system of claim 1 wherein the motive assembly comprises one of the first and second spools connected to an output drive of one of the at least one motor.
 7. The system of claim 1 further comprising an electrically insulating material positioned between the at least one motor and the at least one motive assembly connected to said motor, and/or on a contact portion of the motive assembly for contacting the electrified wire.
 8. The system of claim 7 wherein the at least one motor is an electric motor and the electrically insulating material is positioned between the electric motor and the motive assembly for insulating the electric motor from the wire electrified by the electrification device.
 9. The system of claim 1 wherein the motive assembly comprises one or more of the plurality of guide members being a motive guide member connected to an output drive of one of the at least one motor, said motive guide member having one or more contact portions for contacting the wire and thereby imparting movement from the output drive to the wire.
 10. The system of claim 1 wherein at least one of the following components is comprised of an electrically insulating material: the bath; the first spool; the first spool frame; the second spool; the second spool frame; a support frame for the electrification device; at least one of the plurality of guide members; and the at least one motive assembly.
 11. The system of claim 10 wherein the first spool frame; the second spool frame; and the support frame for the electrification device are comprised of an electrically insulating material sufficient to prevent conduction of the high voltage and high current from the power source.
 12. The system of claim 1 wherein the components are configured, electrically insulated or electrically isolated such that arcing of the high voltage and high current from electrified components of the system or the electrified wire is prevented.
 13. The system of claim 1 further comprising a controller connected to and configured to control at least one of the at least one motor, the power supply, and an optional cooling system.
 14. The system of claim 13 further comprising a cooling system in fluid communication with the bath for cooling the aqueous electrolytic solution and at least partially comprised of an electrical insulating material for preventing conduction of the high voltage and high current.
 15. The system of claim 13 wherein the controller is connected to the motor and configured to control a speed of the motive assembly for controlling speed of the wire to maintain a residence time of the wire in the bath.
 16. The system of claim 1 wherein during use the electrified wire contacts the aqueous electrolytic solution, the high voltage and high current passes from the electrified wire acting as an anode to the cathodic connection, thereby forming a plasma around the wire with the precursor in the solution, resulting in electro-ceramic coating deposition.
 17. The system of claim 1 further comprising a cleaner station positioned between the bath and the second spool to remove excess liquid from the wire before the wire reaches the second spool.
 18. The system of claim 1 further comprising at least one of a cleaning device and a water spray positioned between at least one of the first spool and the bath and the second spool and the bath.
 19. The system of claim 1 wherein the precursor in the aqueous electrolytic solution comprises at least one of a complex metal fluoride and a metal oxyfluoride.
 20. The system of claim 1 wherein the first spool is provided with a bare wire comprising one of aluminum and an aluminum alloy which extends from the first spool to the electrification device, into the bath, out of the bath, and around the second spool.
 21. A process for forming a wire having a selected emissivity comprising:
 - feeding bare wire through a bath having a cathodic connection and containing an aqueous solution comprising a precursor for an electro-ceramic coating;
 - operating an electrification device in electrical communication with the bare wire thereby electrifying the bare wire with a high voltage and a high current;
 - passing the electrified bare wire through the aqueous solution comprising a precursor for an electro-ceramic coating in the presence of the cathodic connection thereby passing current from the electrified bare wire through said aqueous solution to the cathodic connection; and
 - electrochemically reacting the wire with the precursor for an electro-ceramic coating thereby generating a coated wire having an electro-ceramic coating on at least one surface.
 22. The process of claim 21 further comprising:
 - controlling at least one of aqueous solution content, waveform, voltage, amperage, and contact time during a residence time of the electrified wire in the bath to

thereby produce a selected emissivity on the coated wire having an electro-ceramic coating on at least one surface.

23. The process of claim **21** wherein the waveform is pulsed DC and the process further comprises controlling the on/off ratio of the waveform.

24. The process of claim **21** wherein the coating includes a metal/metalloid oxide electro-ceramic comprising aluminum oxide and titanium dioxide.

25. The process of claim **21** wherein an emissivity of the coating is greater than an emissivity of the bare wire, measured under like conditions.

26. The process of claim **21** wherein electrochemically reacting the wire with the precursor in the bath includes providing the wire as an anode and providing a cathode in the bath.

27. The process of claim **26** wherein electrochemically reacting the wire forms a visible light-emitting discharge adjacent to immersed wire being coated.

28. The process of claim **21** wherein the electrification device is a mercury rotary contact.

29. The process of claim **21** further comprising:
continuously collecting coated wire onto a second spool;
and

driving one of a first spool and the second spool to continuously feed bare wire from the first spool into the bath using an electric motor.

30. The process of claim **21** further comprising supporting a first spool for bare wire, the electrification device, and an electric motor on a frame; and electrically insulating the electric motor from the frame and the wire.

31. The process of claim **21** further comprising maintaining the aqueous solution at a temperature in a range of twenty to forty degrees Celsius.

32. The process of claim **31** further comprising cooling the aqueous solution to maintain the temperature within the range.

33. The process of claim **21** further comprising:
continuously collecting coated wire onto a second spool;
and

controlling a speed of an output shaft of an electric motor to control a rotational speed of one of a first spool for bare wire and the second spool to maintain a residence time of the wire in the bath.

34. The process of claim **21** wherein the residence time is five to 30 seconds.

35. A coated metal wire or strip made according to the process of claim **21** wherein the coated metal wire or strip

has a surface area that is at least 10 times greater than the bare metal wire or strip's surface area, preferably at least 10 times to about 1000 times greater than the bare metal wire or strip's surface area.

36. The coated metal wire or strip of claim **36**, wherein the coating comprises, titanium, oxygen and phosphorus, and optionally aluminum and/or zirconium and has a thickness being in a range of 1 to 50 microns.

37. The coated metal wire or strip of claim **37** wherein aluminum oxide is present in the coating and aluminum oxide concentration is greater at an interface of the coating and the metal wire or strip and decreases with increasing distances away said interface.

38. A system for continuously electrolytically coating a wire for a high tension cable for use as an overhead transmission line, the system comprising:

a bath for an aqueous electrolytic solution containing a precursor for an electro-ceramic coating on a wire;

an electrification device for electrifying the wire via a dry anode connection;

a plurality of guide members positioned to route the wire to electrically engage the electrification device, pass into, through and out of the bath, wherein at least one of the plurality of guide members is a bath guide member removably fixed in position in the bath for routing the wire into contact with the aqueous electrolytic solution;

a motor adapted to move the wire through the plurality of guide members;

a cathodic connection positioned in the bath for contacting the aqueous electrolytic solution; and

a power source electrically connected to the electrification device and the cathodic connection, said power source configured to provide high voltage and high current to the wire through the electrification device such that the wire and the cathode connection are in electrical communication in the bath via the aqueous electrolytic solution.

39. The system of claim **38** further comprising an electrical insulator positioned to isolate the motor from an electrified wire.

40. The system of claim **38** wherein the electrification device is a mercury rotary contact.

41. The system of claim **38** wherein the bath guide member comprises an electrically insulating material.

* * * * *