

(19) AUSTRALIAN PATENT OFFICE

(54) Title
Single-use hygiene article

(51)⁶ International Patent Classification(s)
A61F 13/15 (2006.01) 20060101AFI2005100
A61F 13/15 8BMEP
PCT/EP2004/005053

(21) Application No: 2004243543 (22) Application Date: 2004 .05 .12

(87) WIPO No: W004/105668

(30) Priority Data

(31) Number	(32) Date	(33) Country
103 26 022.6	2003 .06 .02	DE

(43) Publication Date : 2004 .12 .09

(71) Applicant(s)
Paul Hartmann AG

(72) Inventor(s)
Rohrl, Wolfgang, Stupperich, Hans-Peter

(74) Agent/Attorney
Griffith Hack, Level 19 109 St Georges Terrace, Perth, WA, 6000

(56) Related Art
US 5462541
US 5624423

(12) NACH DEM VERTRAG ÜBER DIE INTERNATIONALE ZUSAMMENARBEIT AUF DEM GEBIET DES PATENTWESENS (PCT) VERÖFFENTLICHTE INTERNATIONALE ANMELDUNG

(19) Weltorganisation für geistiges Eigentum
Internationales Büro



(43) Internationales Veröffentlichungsdatum
9. Dezember 2004 (09.12.2004)

PCT

(10) Internationale Veröffentlichungsnummer
WO 2004/105668 A1

- (51) Internationale Patentklassifikation: A61F 13/494, 13/475, 13/532, 13/535 (71) Anmelder (für alle Bestimmungsstaaten mit Ausnahme von US): PAUL HARTMANN AG [DE/DE]; Paul-Hartmann-Strasse 12, 89522 Heidenheim (DE).
- (21) Internationales Aktenzeichen: PCT/EP2004/005053 (72) Erfinder; und
- (22) Internationales Anmeldedatum: 12. Mai 2004 (12.05.2004) (75) Erfinder/Anmelder (nur für US): RÖHRL, Wolfgang [DE/DE]; Böllstrasse 34, 89542 Herbrechtingen (DE). STUPPERICH, Hans-Peter [DE/DE]; Hauptstrasse 86, 89552 Heidenheim (DE).
- (25) Einreichungssprache: Deutsch (74) Anwalt: FRIZ, Oliver; Patentanwälte Dreiss, Tuhlendorf, Steimle & Becker, Postfach 10 37 62, 70032 Stuttgart (DE).
- (26) Veröffentlichungssprache: Deutsch
- (30) Angaben zur Priorität: 103 26 022.6 2. Juni 2003 (02.06.2003) DE

[Fortsetzung auf der nächsten Seite]

(54) Title: SINGLE-USE HYGIENE ARTICLE

(54) Bezeichnung: HYGIENEARTIKEL ZUM EINMALIGEN GEBRAUCH

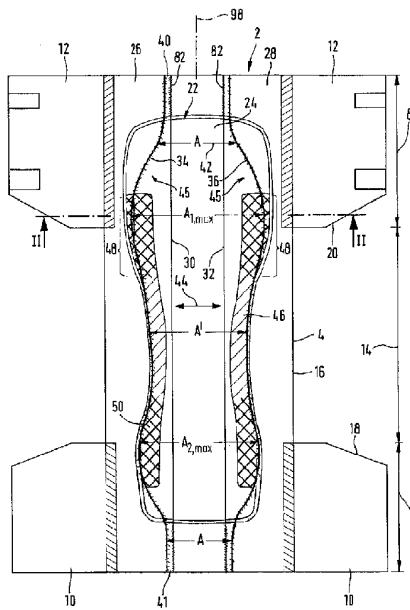

(57) Abstract: The invention relates to a single-use hygiene article, comprising an absorbent body layer (24, 60, 70), which serves to store body fluids and which can also contain superabsorbent materials, and comprising standing cuff elements (26, 28), which extend in an essentially longitudinal direction, form a lateral leakage barrier and which are attached to the body-facing side of the article at least along a cuff base line (34, 36; 62, 64; 76, 78). Said cuff elements (26, 28) are guided with variable distances of the cuff base lines (34, 36; 62, 64; 76, 78) from one another. The aim of the invention is to improve the absorption characteristics of the hygiene article. To this end, the article is designed in such a manner that the absorbent body layer (24, 60, 70) comprises, in a transversal direction (44) of the hygiene article up to the lateral edges (16) and/or in a longitudinal direction (38) up to at least one longitudinal end (40), an increasing mass per unit area of an absorbent material of this layer. In addition, the area (46, 56, 74) of the greater mass per unit area has at least one partial area (48, 66) in which the distance (42) of the cuff base lines (34, 36; 62, 64; 76, 78) from one another is greater than outside this partial area (48, 50, 66, 68).

(57) Zusammenfassung: Die Erfindung betrifft einen Hygieneartikel zum einmaligen Gebrauch, mit einer der dauerhaften Speicherung von Körperflüssigkeiten dienenden Saugkörperschicht (24, 60, 70), die auch superabsorbierende Materialien enthalten kann, und mit eine seitliche Auslaufsperrbildenden im wesentlichen in einer Längsrichtung verlaufenden aufstehenden Cuffelementen (26, 28),

WO 2004/105668 A1

die zumindest entlang

[Fortsetzung auf der nächsten Seite]



(81) **Bestimmungsstaaten** (soweit nicht anders angegeben, für jede verfügbare nationale Schutzrechtsart): AE, AG, AI, AM, AU, AZ, BA, BB, BG, BR, BW, BY, BZ, CA, CH, CN, CO, CR, CU, CZ, DE, DK, DM, DZ, EC, EE, EG, ES, FI, GB, GD, GE, GH, GM, HR, HU, ID, IL, IN, IS, JP, KI, KG, KP, KR, KZ, LC, LK, LR, LS, LT, LU, LV, MA, MD, MG, MK, MN, MW, MX, MY, NA, NI, NO, NZ, OM, PG, PH, PL, PT, RO, RU, SC, SD, SE, SG, SK, SL, SY, TJ, TM, TN, TR, TT, TZ, UA, UG, US, UZ, VC, VN, YU, ZA, ZM, ZW.

(84) **Bestimmungsstaaten** (soweit nicht anders angegeben, für jede verfügbare regionale Schutzrechtsart): ARIPO (BW, GH, GM, KI, LS, MW, MZ, NA, SD, SL, SZ, TZ, UG,

ZM, ZW), eurasisches (AM, AZ, BY, KG, KZ, MD, RU, TJ, TM), europäisches (AT, BE, BG, CH, CY, CZ, DE, DK, EE, ES, FI, FR, GB, GR, HU, IE, IT, LU, MC, NL, PL, PT, RO, SE, SI, SK, TR), OAPI (BF, BI, CF, CG, CI, CM, GA, GN, GQ, GW, ML, MR, NE, SN, TD, TG).

Veröffentlicht:

— mit internationalem Recherchenbericht

Zur Erklärung der Zweibuchstaben-Codes und der anderen Abkürzungen wird auf die Erklärungen ("Guidance Notes on Codes and Abbreviations") am Anfang jeder regulären Ausgabe der PCT-Gazette verwiesen.

einer Cuffsockellinie (34, 36; 62, 64; 76, 78) an der körperzugewandten Seite des Artikels festgelegt sind, wobei die Cuffelemente (26, 28) mit variierendem Abstand der Cuffsockellinien (34, 36; 62, 64; 76, 78) voneinander geführt sind; um die Absorptionseigenschaft zu verbessern ist der Hygieneartikel so ausgebildet, dass die Saugkörperschicht (24, 60, 70) in Querrichtung (44) des Hygieneartikels zu den Seitenrändern (16) hin und/oder in Längsrichtung (38) zu wenigstens einem Längsende (40) hin ein zunehmendes Flächengewicht eines absorbierenden Materials dieser Schicht aufweist und dass der Bereich (46, 56, 74) grösseren Flächengewichts zumindest einen Teilbereich (48, 66) aufweist, in dem der Abstand (42) der Cuffsockellinien (34, 36; 62, 64; 76, 78) voneinander grösser ist als außerhalb dieses Teilbereichs (48, 50, 66, 68).

2004243543 11 Mar 2009

1

Single-use hygiene article

Description

Embodiments of the invention concern a single use hygiene article having an absorptive body layer suitable for long term storage of body fluids which may contain super-absorbing materials and with cuff elements forming a sideward discharge blockage which are substantially disposed in a longitudinal direction at least through sections and which are attached, at least along a cuff base line, to the side of the article facing the body of the user, wherein the cuff elements are guided at variable separations from each other with respect to their cuff base lines. Embodiments of the invention also concern a diaper or diaper pants and incontinence inlays or incontinence diapers or pants. A hygiene article of this type is e.g. described in EP0751756B1. In this hygiene article, the cuff elements or their cuff base lines follow the hour glass shape of the absorptive body.

EP0254476B1 discloses an absorptive body structure having a central liquid retention zone of reduced density and reduced basis weight which is at least partially surrounded by a storage zone of higher density and higher basis weight. This is intended to increase the capacity for fluid retention as well as distribution in particular in the case of liquid floods. A similar teaching is disclosed by EP1006970B1.

Departing therefrom, it would be advantageous if the present invention would provide a hygiene article which is well suited, in particular in the event of flooding of liquids, to prevent sideward leakage and to assure that the incident liquid

2004243543 11 Mar 2009

is rapidly absorbed and stored for a long period of time in the absorbing structure and in the absorptive body layer.

The present invention provides in a first aspect a hygiene article of the above mentioned kind in that the absorptive layer has a basis weight of absorbing material which increases in a transverse direction of the hygiene article towards the side edges and/or in the longitudinal direction towards at least one longitudinal end, wherein the region of increased basis weight density has at least one partial region in which the separation between the cuff base lines with respect to each other is larger than outside of this partial region.

In accordance with embodiments of the present invention, it has been discovered that the cuff elements can be guided at variable cuff base line separations. For example, in the forward region or in the rear region, i.e. outside of the crotch region of the hygiene article, the lines are further separated from each other thereby leading to an increase surface area which is available for the retention of fluids in particular in the case of flooding fluid loading on the surface of the hygiene article with the fluids being distributed between the elevated cuff elements. It has turned out to be advantageous for rapid fluid absorption when the absorbing area is chosen to be as large as possible. However, this has the consequence that the cuff elements and the pockets built thereby for the retention of body discharges are located in the region of the edge of the absorptive material where the absorptive capacity could be insufficient or, due to interactions with the edge of the absorptive body, an insufficient sealing or retention capacity is present. Moreover, the fixation of the cuff elements to the materials of the hygiene article can cause undesired capillary transport

2004243543 11 Mar 2009

of the fluid towards the edges of the hygiene article should insufficient absorption capacity be available. Embodiments of the current invention therefore recognize that, by increasing the basis weight of the absorbing material of the absorptive body precisely at those locations where the separation between the cuff base lines is maximized compared to other areas, improved and more reliable liquid retention properties of the hygiene article can be achieved. This increase in the basis weight can be provided in a transverse direction towards the side edges so that both transverse sides outside of the central region have higher surface densities than in the central region. The increase in basis weight can thereby be effected continuously or discontinuously.

An increased basis weight can also be provided in the longitudinal direction towards at least one longitudinal end of the hygiene article. This leads to an increase of basis weight in the front region and/or in the rear region compared to the middle region, wherein, in accordance with embodiments of the invention, at least a partial region of the regions of increased basis weight has separations between the cuff base lines which are larger than outside of this partial region.

It has therefore been discovered in accordance with embodiments of the invention that the guidance of the cuff elements and the cuff base lines advantageously creates a larger fluid retention capacity region in areas of larger separation between the cuff base lines to create a higher absorption capacity for permanent or long term storage of body fluids in the absorptive body layers and in the region of the cuff base lines.

Although the concepts in accordance with embodiments of the invention can also be utilized in the middle, crotch region of the hygiene article, it has turned out to be particularly advantageous when the above mentioned partial regions are located outside of the middle longitudinal section in either a front and/or in a rear region of the hygiene article. In these locations of the hygiene article, the absorptive body structure in the transverse direction is more easily configured than in the crotch region. Since the functionality of the hygiene article should also be guaranteed for users who are prone or sleeping, the front region and the rear region are more important for liquid retention than has been assumed up to this point in time. Although "boy" diapers have been proposed having increasing absorptive capacity in the front region, this absorptive capacity was centrally located i.e. in the middle region. In accordance with embodiments of the present invention, an increased storage capacity is achieved by the cuff base lines through an increased basis weight of absorptive material for long term storage of body fluids using an absorptive body layer which has a maximum separation between the cuff base lines.

In accordance with a further preferred embodiment of the invention, the cuff line elements are guided in such a fashion that the separation between the cuff base lines in the longitudinal direction has at least one maximum and preferably has a maximum in both the forward as well as in the rear region of the hygiene article. The reference hereto to passage through a maximum means that the separation between the cuff base lines increases in the longitudinal direction up to a maximum value and then once more decreases, i.e. the cuff base lines once more approach each other.

2004243543 11 Mar 2009

The cuff elements themselves may include such materials which are conventionally used to form discharge blockings such as fleece materials for example card web, spun or melt blown fleece materials in particular fleece material laminates which includes spin(S) and melt blown (M) fleece layers in particular SM, SMS, SMMS fleece layer. Hydrophobic materials are preferentially used. However, cuff elements made from foils or foam materials can also be used.

In order to configure the absorptive body layer whose basis weight can increase in the transverse direction and/or in the longitudinal direction there are no particular requirements which deviate substantially from those of usual absorptive body materials for long term storage of body fluids. One can thereby use a layer of pure fiber material in particular fluffed cellulose fibers which are suitable for long term storage of liquids due to their hydrophobicity. Moreover, one can use synthetic in particular thermoplastic fibers optionally mixed with cellulose fibers. It has been particularly advantageous when the absorptive body structure includes super-absorbing materials in particular particle shaped super-absorbing materials. The absorptive body materials preferentially include a homogenous mixture of fibers and particle shaped super-absorbing materials. The absorptive body layer can furthermore be made from foam materials or include such materials.

In accordance with an embodiment of the invention, the base lines of the cuff elements which extend on both sides join each other in the front region and/or in the rear region. In this case, a pocket is created which seals in the longitudinal direction for the absorption of body discharge. The cuff elements themselves will then be

2004243543 11 Mar 2009

preferentially configured in such a fashion that their distal ends touch each other or overlap. In this fashion a type of window opening is created.

Alternatively it would also be conceivable and particularly advantageous with regard to manufacturing considerations if the socket lines of the cuff elements extending on both sides are separated from each other in the front region and/or in the rear region and extend up to the longitudinal end of the hygiene article at a separation with respect to each other.

In a further precise embodiment of the concept in accordance with the invention, the hygiene article is configured in such a fashion that the surface density of the absorptive body layer, or one of the absorbing materials, increases in the transverse or longitudinal directions by 30 to 200 %, in particular by 30 to 150 %, and preferentially by 50 to 120 %.

In accordance with a preferred embodiment of the invention, the basis weight of absorbing material of the absorbing body layer outside of said partial region assumes values of 200-500 g/m², in particular 250-450 g/m² and preferentially 280-350 g/m². In the partial region, it assumes values of 250-1000 g/m², in particular 350-750 g/m² and preferentially 500-700 g/m². The absorbing material of the absorptive body layer can be formed from fiber components in particular fluffed cellulose fibers.

Further, in particular, fluid retaining or storing absorptive body components can be provided above and/or below the absorptive body layer. For example, a preferentially open pored liquid retaining layer can be

2004243543 11 Mar 2009

provided which is, however, preferentially not used for long term storage, rather only for acceptance and distribution of the liquid. A further preferentially SAP free layer disposed below the above mentioned absorptive body layer has also turned out to be advantageous. This layer serves as a substrate, in particular, to prevent escape of the grainier super-absorbing particle materials from the absorptive body layer.

In accordance with a particularly preferred embodiment of the present invention, the cuff elements are formed from tracks or track sections extending in the longitudinal direction. When these tracked sections define a desired dependence of the associated cuff base lines, the cuff elements are configured in such a fashion that the separation of a distal end of the elevated cuff elements from the corresponding cuff base line becomes larger the greater the separation of the cuff base lines from each other. This is also advantageous, since an increased effective height can be assumed in the widely extended, receiving regions of the elevated cuff elements. In a further improvement of the inventive concept, the separation of a distal end of the elevated cuff elements from the cuff base line within the above mentioned partial region advantageously is larger than outside of this partial region.

It has turned out to be advantageous and practical, when the separation between the distal end of the elevated cuff element from the cuff base line within the above mentioned partial region has values of 40-60 mm. The separation is therefore understood as an effective length in the event of flat cuff elements. The separation is preferentially 30-40 mm outside of the above mentioned partial region.

The present invention provides in a second aspect a hygiene article for single use with an absorbing body layer for long-term storage of body fluids which may contain super-absorbing materials, and with cuff elements forming sideward blockage of transverse discharge and extending substantially in a longitudinal direction, which are at least partially elevated and which are attached to the side of the article facing the body of the user at least along a cuff base lines, wherein the cuff elements extend with changing distances between their cuff base lines, characterized in that the absorbing body layer has a basis weight of absorbing material which increases in the transverse direction of the hygiene article towards the side edges and/or in the longitudinal direction towards at least one longitudinal end, and the region of basis weight has at least one partial region in which the separation between the cuff base lines is larger than outside of this partial region, wherein the separation of the distal end of the elevated cuff elements from the cuff base lines within said partial region is greater than it is outside of said partial region.

Further features, details and advantages of the invention can be extracted from the figures and the following description of preferred embodiments.

Fig. 1 show a plan view of a hygiene article in accordance with a preferred embodiment of the invention.

Fig. 2 shows a cut through the hygiene article according to Fig. 1 in the cut plane II-II of Fig. 1.

- Fig. 3 shows a plan view of an absorptive body of a further embodiment with the indicated dependence of the cuff base lines;
- Fig. 4 shows a plan view of an absorptive body of an additional embodiment with indicated dependence of the cuff base line; and
- Fig. 5 shows longitudinal side view of the absorptive body of Fig. 3.

Fig. 1 shows a plan view of the side of a hygiene article facing the body of the user and indicated in its totality with reference symbol 2 in the form of an incontinence diaper in the flat state. Fig. 2 shows a corresponding section in the section plane along line II-II of Fig. 1. The hygiene article 2 includes a diaper chassis having side flaps 10 or 12 directly or indirectly introduced on both sides of a forward region 6 and a rear region 8. The region between the front region 6 and the rear region 8 is designated as a crotch region 14. A sideward edge 16 of the diaper body 4 in the crotch region together with the immediately adjacent side edges 18, 20 of the side flaps 10 and 12 define the leg openings of the user in the state of use of the hygiene article.

The chassis has a liquid impermeable layer 7 on its side facing away from the body of the user, whereas the side flaps 10, 11 are made from an actively breathing material, preferably an air permeable fleece material.

The hygiene article 2 also includes an absorptive body 22 and

an open pore liquid retaining or distribution layer which only partially covers the absorptive body (not shown). The absorptive body 22 also includes an absorptive body layer 24 serving for long term storage of body fluids, which will be described more closely below. The absorptive body layer 24 seats on a thin layer made from fluffed cellulose (not shown in Fig. 1 and 2) which has a uniform surface density of approximately 140 g/m².

Cuff elements 26, 28 extend in a longitudinal direction at least in the crotch region in an elevated fashion and have free distal edges 30, 32 which are preferentially provided with an elastic means. In order to prevent the cuff elements from folding over in an outward direction, the distal edges 30, 32 in the rear and forward regions are equipped with inwardly disposed attachments on the upper side of the hygiene articles using conventional procedures such as gluing or welding. The cuff elements 26, 28 are also introduced along each of the corresponding cuff base lines 34, 36 on the upper side of the hygiene article 2 and are, in particular, connected to at least one top sheet layer 9 (Fig. 2) which substantially covers the chassis 4.

The cuff base lines 34, 36 extend, as do the cuff elements, in the longitudinal direction 38 of the hygiene article. However, they are not parallel with respect to that longitudinal direction 38, rather are guided with varying separation between the cuff base lines 34, 36.

Departing from the longitudinal end 40 of the hygiene article 2, the cuff base lines 34, 36 initially extend precisely parallel to the longitudinal direction 38 at a separation 42 designated by value A. Within the rear region 8, the cuff base

lines 34, 36 then proceed continuously in an arched-shaped fashion towards the outside so that their separation 42 continuously increases up to a maximum value A_{1max} . The separation then decreases continuously from the value A_{1max} through a value A' in the crotch region 14 of the hygiene article 2 which is, however, several millimeters larger than the separation A . In further travel of the cuff base lines 34, 36 from the crotch region into the forward region 6, the separation between the cuff base lines 34, 36 increases in a continuous fashion up to a value A_{2max} , which is somewhat smaller than the value A_{1max} and then decreases once more towards the longitudinal end 44 to the initial value A .

The cuff elements 26, 28 are thereby guided in such a fashion that the separation between the cuff base lines 34, 36 in the longitudinal direction passes through maxima which are preferentially at least partially disposed in the forward region 26 or in the rear region 8 of the hygiene article. As indicated in the current embodiment, if the distal edges 30, 32 of the cuff elements in the rear and forward regions are introduced towards the inside on the upper side of the hygiene article (cuff end attachment 82) pocket shaped barriers (45) result which, in addition to assisting in the primary function of the cuff elements of preventing sideward discharge also constitute a discharge, barrier towards the waist edges. This is particularly advantageous when, as indicated, the cuff base lines taper inwardly in a substantially even fashion towards the front end or the rear region in the region of the cuff end attachments.

The absorptive body layer 24 which serves for long term storage of body fluids, is non-homogeneous i.e. it does not have a constant basis weight throughout its entire extent, rather

its basis weight increases in the transverse direction 44 towards the side end edges 16 and it has a region 46 of higher weight of absorptive body material which is fashioned from homogenous mixture of cellulose fibers and super-absorbing particle shaped materials. This can be seen from the section of Fig. 2. This hatched region 46 of increased basis weight extends along an edge of the absorptive body and includes at least one partial region 48 (cross hatching) in which the separation between the cuff base lines 34, 36 with respect to each other is larger than outside of this partial region 48. The largest separation 42 between the cuff base lines 34, 36 or a maximum separation 42 between the cuff base lines 34, 36 is disposed in a longitudinal section of the hygiene article where the absorptive body layer 26 has a higher basis weight i.e. where the region 46 is also located. The increase in the absorptive body layer 24 in the edge region leads to an increased storage capacity at those areas. This is particularly advantageous in the partial regions 48, 50 of the region 46 in that the separation 48 between the cuff base lines 34, 36 is increased. This leads to improved absorption characteristics in particular for rapid retention of body fluids. This is the case in the front regions 6 and in the rear regions 8 due to the larger increasing separation between the cuff base line 34, 36 with respect to each other and thereby allows for a larger load of fluid retaining absorbing materials which is particularly advantageous in the event of bowel incontinence in the rear region of the product. Widely extending retention regions for body discharges are created precisely in the region of the liquid barriers and are formed by the elevated cuff elements 30, 32 for increased storage capacity and increased protection with respect to sideward liquid discharge.

Fig. 3 show a plan view of an absorptive body 52 of the hygiene article in accordance with a further embodiment of the invention. As with the absorptive body 24 of the hygiene article according to Fig. 1, the absorptive body 52 has an increasing basis weight in the transverse direction 44 towards the sideward longitudinal edges 54 as indicated by hatched regions 56. There is a thin fluffed layer 58 of uniform surface density which is disposed between the absorptive body layer 60 and a back sheet (not shown). Cuff elements are indicated by their cuff base lines 62, 64 and their distal end 65 and extend in the longitudinal direction with varying separations A between the cuff base lines 62, 64. Moreover, at least a partial region 66, 68 of the region 56 of increased basis weight has a cuff base line separation 42 which is larger than outside of the partial region 66, 68.

In contrast to Fig. 1, the region 56 of higher basis weight is closed in a ring-like fashion in the forward region of the absorptive body 52 (see Fig. 3). This embodiment is advantageously used in an incontinence article for men.

It has turned out to be advantageous for both embodiments when the increase in basis weight is accompanied by an increased thickness of the absorptive body layer and thereby of the absorptive body. This supports the leakage properties in a region of the edge of the absorptive bodies in a highly effective manner.

Fig. 4 and 5 show a plan view as well as a section through an additional absorptive body layer 70 in accordance with an embodiment of the invention. In contrast to the embodiments according to Fig. 1 and 2, the overall basis weight of the absorptive body layer 70 increases in the longitudinal

2004243543 11 Mar 2009

direction 38 towards one end 72 of the hygiene article which, for its part, is not shown in Fig. 5. The increase in the thickness of the absorptive body layer 70 is effected by means of a ramp-like increase between the crotch region and the front region or the rear region of the hygiene article. One notices the region 74 of increased basis weight. Also schematically shown is the travel of the cuff base lines 76, 78 and the distal ends 80 of the cuff elements. One notices that the cuff base lines 76, 78 have a maximum mutual separation which is disposed in the region 74 of increased basis weight.

It is to be understood that, if any prior art publication is referred to herein, such reference does not constitute an admission that the publication forms a part of the common general knowledge in the art, in Australia or any other country.

In the claims which follow and in the preceding description of the invention, except where the context requires otherwise due to express language or necessary implication, the word "comprise" or variations such as "comprises" or "comprising" is used in an inclusive sense, i.e. to specify the presence of the stated features but not to preclude the presence or addition of further features in various embodiments of the invention.

Claims

1. Hygiene article for single use with an absorbing body layer for long-term storage of body fluids which may contain super-absorbing materials, and with cuff elements forming sideward blockage of transverse discharge and extending substantially in a longitudinal direction, which are at least partially elevated and which are attached to the side of the article facing the body of the user at least along a cuff base lines, wherein the cuff elements extend with changing distances between their cuff base lines, characterized in that the absorbing body layer has a basis weight of absorbing material which increases in the transverse direction of the hygiene article towards the side edges and/or in the longitudinal direction towards at least one longitudinal end, and the region of basis weight has at least one partial region in which the separation between the cuff base lines is larger than outside of this partial region, wherein the separation of the distal end of the elevated cuff elements from the cuff base lines within said partial region is greater than it is outside of said partial region.
2. Hygiene article of claim 1, characterized in that the partial region is disposed outside of a middle longitudinal section in a forward section and/or in a rear area of the hygiene article.
3. Hygiene article according to claim 1 or 2, characterized in that the cuff elements extend in such a fashion that the separation between the cuff base lines along the

longitudinal direction has at least one maximum.

4. Hygiene article according to claim 3, characterized in that the maximum is completely within said partial region of the region having large surface density.
5. Hygiene article according to claim 3 or 4, characterized in that the maximum of the separation between the cuff base lines is in a forward region and/or in a rear region of the hygiene article.
6. Hygiene article according to any one of the preceding claims, characterized in that the absorptive body layer includes a mixture of fibers and particle shaped super-absorbing materials.
7. Hygiene article according to any one of the preceding claims, characterized in that the cuff base lines of the cuff elements extending along both sides in the forward region and/or in the back region join into each other.
8. Hygiene article according to any one of the preceding claims, characterized in that the cuff base lines of the cuff elements which extend along both sides are separated from each other at or extend past the longitudinal end in the forward region and/or in the rear region.
9. Hygiene article according to any one of the preceding claims, characterized in that the separation between the cuff base lines in a middle longitudinal section of the hygiene article and outside of said partial region is 130

to 170 mm, in particular 140-165 mm.

10. Hygiene article according to any one of the preceding claims, characterized in that the separation between the cuff base lines in partial regions is 160-220 mm, in particular 180-200 mm, in particular 185-195 mm.
11. Hygiene article according to any one of the preceding claims, characterized in that the separation between the cuff base lines in the product end region including the longitudinal end of the hygiene article assumes values of 100-180 mm, in particular 100-160 mm, in particular 100-150 mm, in particular 100-140 mm, in particular 100-130 mm, in particular 105-120 mm.
12. Hygiene article according to any one of the preceding claims, characterized in that the basis weight of the absorbing body layer or of one of its absorbing materials increases by 30-200 %, in particular by 30-150 %, in particular by 50-120 % in the transverse or in the longitudinal directions.
13. Hygiene article according to any one of the preceding claims, characterized in that the basis weight of an absorbing material in the absorptive body layer outside of said partial region is 200-500 g/m², in particular 250-450 g/m², in particular 280-350 g/m².
14. Hygiene article according to any one of the preceding claims, characterized in that the basis weight of the absorbing material of the absorptive body layer inside of said partial region is 250-1000 g/m², in particular

2004243543 11 Mar 2009

350-750 g/m², in particular 500-700 g/m².

15. Hygiene article according to any one of the preceding claims, characterized in that the separation between the distal end of the elevated cuff elements and the cuff base lines within said partial region is 40-60 mm.
16. Hygiene article according to any one of the preceding claims, characterized in that the separation between the distal end of the elevated cuff elements and the cuff base lines outside of said partial region is 30-40 mm.
17. Hygiene article substantially as herein described with reference to any one of the drawings.

1/3

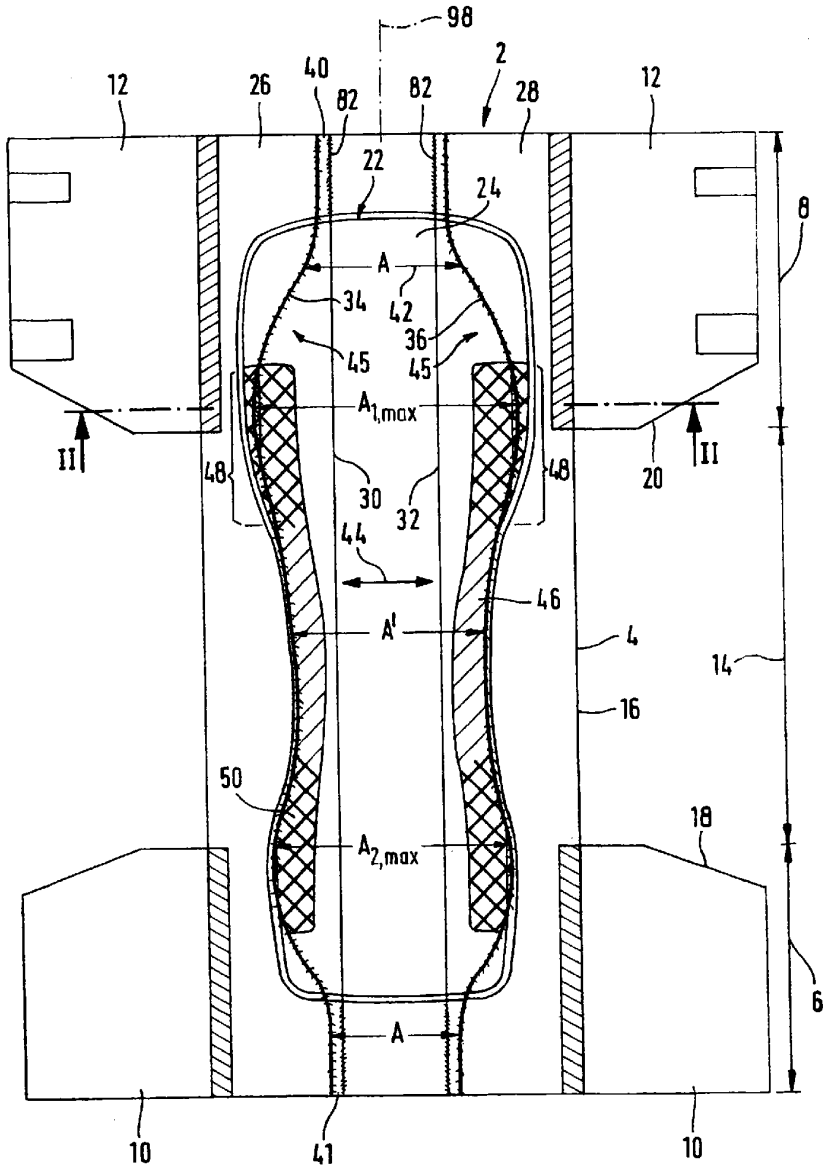

Fig. 1

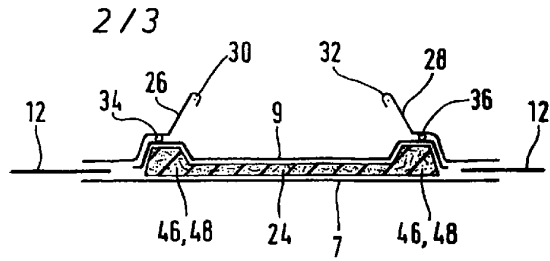

Fig. 2

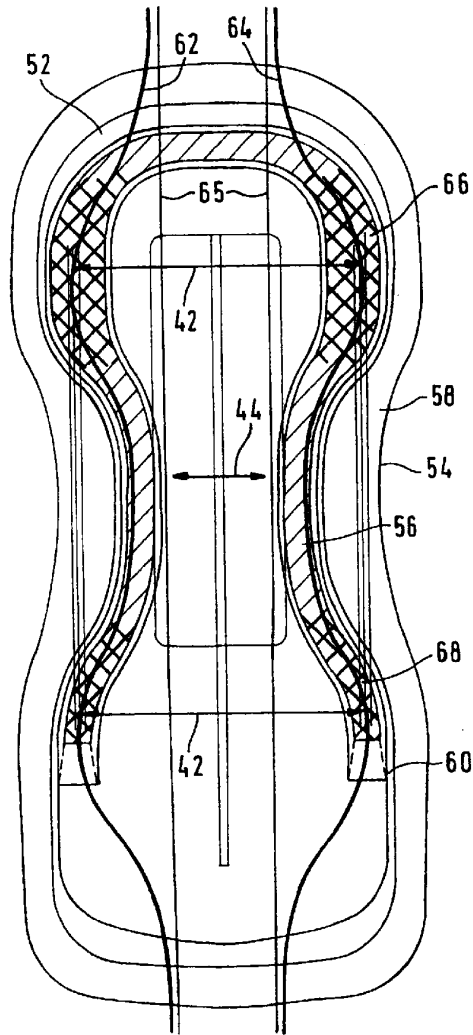

Fig. 3

3 / 3

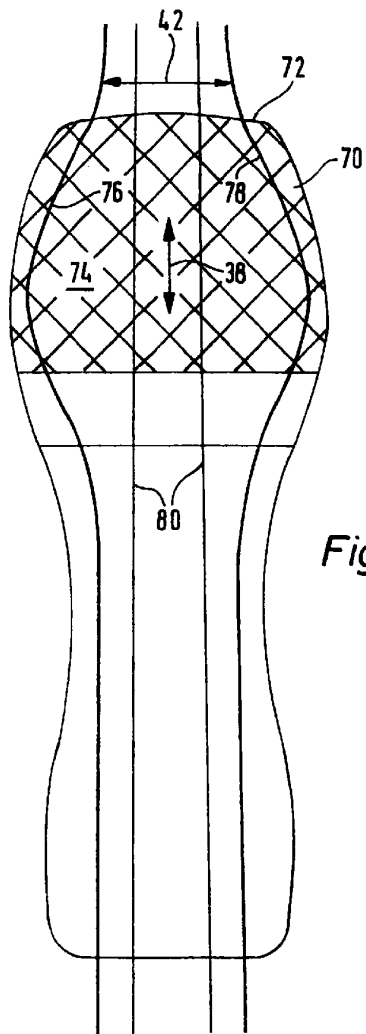

Fig. 4

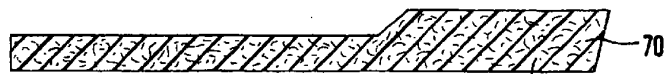

Fig. 5

74