

(19) World Intellectual Property Organization
International Bureau



(43) International Publication Date
25 July 2002 (25.07.2002)

PCT

(10) International Publication Number
WO 02/057526 A1

- (51) International Patent Classification⁷: **D02J 1/00**
- (21) International Application Number: PCT/US01/26392
- (22) International Filing Date: 23 August 2001 (23.08.2001)
- (25) Filing Language: English
- (26) Publication Language: English
- (30) Priority Data:
09/766,249 17 January 2001 (17.01.2001) US
- (71) Applicant and
(72) Inventor: **PATRICK, Gilbert** [US/US]; 635 Dixon School Road, Kings Mountain, NC 28086 (US).
- (74) Agent: **SUDDERTH, Scott, D.**; Womble Carlyle Sandridge & Rice, PLLC, P.O. Box 7037, Atlanta, GA 30357-0037 (US).
- (81) Designated States (*national*): AE, AG, AL, AM, AT, AU, AZ, BA, BB, BG, BR, BY, BZ, CA, CH, CN, CR, CU, CZ, DE, DK, DM, DZ, EE, ES, FI, GB, GD, GE, GH, GM, HR, HU, ID, IL, IN, IS, JP, KE, KG, KP, KR, KZ, LC, LK, LR, LS, LT, LU, LV, MA, MD, MG, MK, MN, MW, MX, MZ, NO, NZ, PL, PT, RO, RU, SD, SE, SG, SI, SK, SL, TJ, TM, TR, TT, TZ, UA, UG, UZ, VN, YU, ZA, ZW.
- (84) Designated States (*regional*): ARIPO patent (GH, GM, KE, LS, MW, MZ, SD, SL, SZ, TZ, UG, ZW), Eurasian patent (AM, AZ, BY, KG, KZ, MD, RU, TJ, TM), European patent (AT, BE, CH, CY, DE, DK, ES, FI, FR, GB, GR, IE, IT, LU, MC, NL, PT, SE, TR), OAPI patent (BF, BJ, CF, CG, CI, CM, GA, GN, GQ, GW, ML, MR, NE, SN, TD, TG).
- Published:**
— with international search report
- For two-letter codes and other abbreviations, refer to the "Guidance Notes on Codes and Abbreviations" appearing at the beginning of each regular issue of the PCT Gazette.*

(54) Title: METHOD OF NEEDLE PUNCHING YARNS

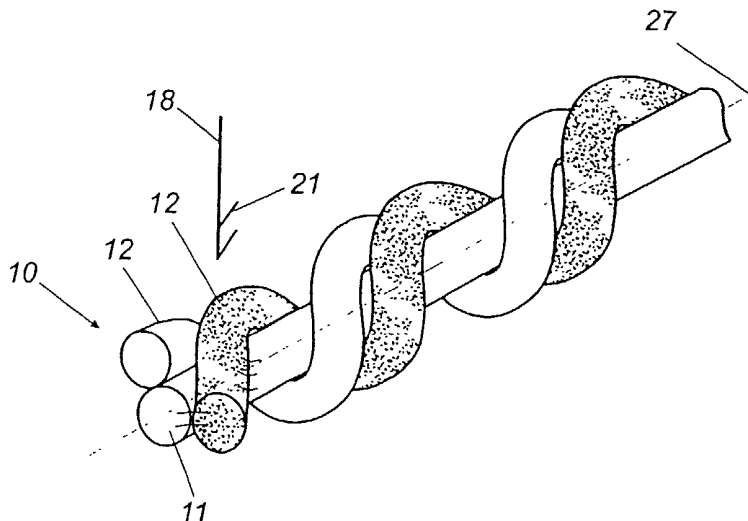

(57) Abstract: A process for producing yarns that have enhanced resistance to unraveling and linting. The yarns (10) are removed along guides (22) through a needle loom (16) where a series of needles (18) engage the yarns. This engagement of the yarns by the needles causes the fibers of the yarns to become intermixed.



WO 02/057526 A1

METHOD OF NEEDLE PUNCHING YARNS

CROSS REFERENCE TO RELATED APPLICATION

This application claims priority to United States Provisional Patent Application
5 Serial No. 60/221,033, filed July 27, 2000.

FIELD OF INVENTION

The present invention generally relates to the processing of yarns, in particular,
the present invention relates to processing spun filament yarns through a needling process
10 to interlock or link the yarn filaments or fibers together.

BACKGROUND OF INVENTION

In yarn manufacturing, yarns generally are spun from one or more fibers,
including natural and/or synthetic fibers, using conventional ring, open-end, air-jet,
15 worsted, woolen, or Dref spinning processes. The yarns then are used in a single form or
ply or are plied together with other yarns or filaments to produce a single but bigger yarn.
One of the principal problems with spun formed yarns generally is the tendency of such
yarns to unravel or fray when cut, and, depending upon the method of spinning, such
yarns generally will have inherently low abrasion qualities. To try to solve this problem it
20 has generally been known to add a low-melt fiber or filament, as a percentage, into the
mass yarn bundle. Thereafter, following completion of the spinning and/or twisting
process, when the yarns are processed through a heat-set range, they are generally
exposed to temperatures and dwell times that melt the low-melt fibers into an adhesive

that bonds the fibers and/or plies of the yarn(s) together. Other methods of solving the unraveling or fraying problem typically consist of adding adhesives to the finished yarn in a costly after-process that also tends to deter their natural surface characteristics.

One example of yarn products where the problem of unraveling and/or
5 diminishment of surface characteristics are especially problematic is mops. Mops usually consist of one or more spun yarns containing cotton and/or other fibers of good absorption and abrasion properties, twisted as a single yarn in a Z rotation. These yarns are then grouped or plied with 2 to 32 ends of the same type yarn or other yarns of
10 different structures or compositions and are twisted in an opposite rotation until the yarn is balanced. Such yarns generally have good absorption properties and are preferred in the janitorial field. However, by their inherent structure, these mops typically tend to unravel or lint as they are used. This shortens the usable life for the mop and tends to cause lint to be distributed on and thus diminish the finish of cleansed surfaces.

To combat this, mops made of non-woven strips have been introduced into the
15 market. These strips are manufactured by carding and forming a fiber mass and adhering it together by adhesives or by thermal bonding. This process, however, tends to diminish or lessen the absorption properties of the mop. Further, while the use of many synthetic fibers has yielded products, such as mops, that have good abrasion properties, such products often do not have good absorption or wicking properties, particularly where the
20 fibers are pressed or tightly linked together. It is therefore seen that a need exists for an economical means of interlocking fibers and plies of spun yarns or filaments together to

form yarns that exhibit better abrasion resistance and wicking, do not unravel as quickly, and have a longer usable life.

SUMMARY OF THE INVENTION

5 The present invention is directed to a process for forming yarns or cordage having enhanced strength and resistance to unraveling, and which link the properties of both spun yarns or fibers having, for example, good absorption, to other materials such as nonwoven strips having, for example, good abrasion properties, but low absorption. The resultant spun yarns, therefore, will be provided with the enhanced absorption properties
10 of a natural or woven fiber yarn and the durable and less-linting properties of a non-woven material yarn.

 Typically, the yarns are spun from a series of natural and/or synthetic fibers, and generally include core fibers wrapped or covered with sheath fibers. The yarns are fed from creels or beams along a feed path into a loom or needling apparatus or system,
15 being pulled through the loom under tension. The yarns are fed along a needle plate having a series of milled grooves, each of which have sloped sides defining a guide channel that is aligned with the feed path and a centerline of each of the yarns. The sloped sides direct the yarns downwardly and toward the center portion or region of the guide channels, so that their centerlines are aligned along the feed path as the yarns are
20 moved through the loom. The loom generally includes a drive plate or carrier that is reciprocally driven toward and away from the yarns passing through the grooves of the needle plate. A series of needles are arranged in spaced, parallel rows or lines of needles

on the drive plate, with each of the needles typically having one or more barbs adapted to catch or pull portions of the core and sheath fibers of the yarns through the yarns as the needles are reciprocated into and out of the yarns. Each row of yarns is aligned directly perpendicular to the centerline of one of the yarns in the grooves so as to penetrate the
5 yarns substantially along the centerlines of the yarns. This helps insure that the needles substantially penetrate and pull fibers through the yarns to substantially intermix and interlock the core and sheath fibers of the yarns.

The grooves or guide channels of the needle plate typically are formed with sufficient depth and slope so that additional yarns can be stacked therein so that multiple
10 yarns can be moved along each guide channel with each of the yarns maintained in a substantially parallel arrangement with their centerlines in alignment with a row of needles. The guide channels further can be arranged in a substantially flat, straight, configuration or can have a curved or arcuate configuration or construction with the needles likewise being carried by a drive plate having a similar curved or arcuate shape
15 so that the configuration of the rows of needles substantially matches that of the guide channels.

In a further embodiment, a fibrous mat can be fed along or over the yarn guides, being run parallel to the yarns for needling and attaching the yarns to a fibrous mat. Strips of material also can be attached to the yarns by positioning the strips over the yarns
20 in the guide channels of the needle plate so that as the needles pierce the fibrous strips or webs and the yarns, fibers from the yarns, and the strips or webs are intermixed and become substantially interlocked so as to form a composite yarn/strip. As a result,

composite material strips, and/or mats can be formed which incorporate different properties of one or more different types of yarns, such as, for example, combining the absorbency of a cotton or similar natural fiber yarn with the abrasive properties of a synthetic or man-made fiber, so as to create a yarn that has high absorbency and good
5 abrasive capabilities but which does not have a tendency to lint or unravel easily, especially after repeated exposure to water and other liquids.

Various objects, features and advantages of the present invention will become apparent to those skilled in the art, upon a review of the following detailed description, when taken in conjunction with the accompanying drawings.

10

BRIEF DESCRIPTION OF THE DRAWINGS

Fig. 1 is a perspective view of a yarn, illustrating the core and sheath fibers.

Fig. 2 is a schematic view illustrating the feeding of yarns from yarn creels through a loom.

15 Fig. 3 is a side elevational view, schematically illustrating the passage of a yarn through one of the yarn guides for engagement by the needles of the present invention.

Fig. 4 is an end view illustrating the movement of yarns through the yarn guides, with the needles being substantially aligned along the center lines of the yarns.

20 Fig. 5A is a side elevational view with parts broken away, illustrating the engagement of the needles with a yarn passing through an arcuate yarn guide.

Fig. 5B is an end view illustrating the penetration of a needle into two parallel yarns.

Fig. 5C is a side elevational view of a pair of welded, interlocked yarns according to the present invention.

Fig. 6 is a perspective view illustrating an additional embodiment of the present invention in which fibrous mat or web is attached to yarns being passed through the yarn
5 guides.

DETAILED DESCRIPTION

The present invention relates to a process of forming needle-punched yarns 10 (Fig. 1) or cordage having improved properties relating to strength, absorption and resistance to unraveling. The yarn typically is a spun yarn in a multi-ply or single-ply
10 form, and typically includes a core fiber or fibers 11 and a sheath or wrapping fiber(s) 12 that are wrapped about and substantially cover the core fiber(s). The yarn can be spun by means of ring, open-end, worsted wool, air-jet, or any other type spinning or in a synthetic filament form, however, it has been found that the more disoriented the fibers are in the yarn, the more effective the present invention. Dref or friction spun yarns
15 further generally display a greater degree of improvement than open-end, ring spun, or vortex spun yarns, although such other types of yarns also can be used in the present invention. The yarns can be composed of natural (i.e., cotton, wool, and the like), manmade or synthetic fibers (i.e., nylon, aramid fibers, plastics and the like) or combinations thereof consisting of a micro-denier fiber to a coarse fiber of 15 – 20
20 denier.

As shown in Fig. 2, the yarns generally are fed from creels 13 along a feed path 14 into a needle loom 16, either as single ends off of creel cones 13 or incorporated

together as on a beam. The loom 16 typically is a needling loom such as a Fehrer H-1 needle loom or similar needling apparatus or system. As shown in Figs 3 and 4, the loom 16 generally includes a reciprocally moving needle carrier or drive plate 17 that carries a series of needles 18, and a needle bed plate 19 positioned directly below the carrier or drive plate 17. The needles generally are polished needles having one or more barbs 21 and a polished surface, and are arranged in defined, spaced rows or lines of needles along the length of the carrier 17.

As the yarns enter the loom, each yarn end is fed along the feed path 14 into and along a ceramic or plastic yarn guide 22 (Fig. 3), such as an eyelet or other guide, with the yarns fed under tension so as not to get tangled up with neighboring yarns. As the yarns enter the yarn guide 22 (Figs. 3 – 4) the yarns are each directed into milled grooves 23 that have been milled or formed in the needle bed plate 19 (Fig. 3) of the loom. The grooves are formed with sloping sides 24 that define guide channels 26 along which the yarns are moved with the centerlines 27 of the yarns being aligned parallel to each other and the feed path 14. The yarns generally are kept taut or under tension in the grooves with a changeable positive draft as they are drawn through the needling zone 28, such as by using tension rolls 29 to pull the yarns through the loom. The yarn guides further generally are positioned lower than the milled grooves 23 so the tension on the yarns keeps each yarn within its respective groove.

As indicated in Fig. 4, the needles 18 of each line of needles on the carrier or drive plate are positioned so that they are directly perpendicular with an axis or centerline 27 of one of the yarns traveling through one of the grooves of the needle bed. This

ensures that the needles penetrate substantially through the center or cores of the yarns and not through the edges of the yarns where needling would be less effective and would also tend to cause fuzzing or distortion of the yarn. As the needles penetrate the centerlines of the yarns, the barbs of the needles tend to urge and engage and pull fibers
5 from the core and sheath fibers through the body of the yarn, i.e., through the core and sheath fibers, so as to cause an intermixing of these fibers. Thus, portions of the core and sheath fibers become intertwined and thus interlocked to create a yarn that is generally more resistant to unraveling and linting, even when cut and/or exposed to liquids, since the fibers are locked together, without requiring application of adhesives or expensive
10 after processing to set the yarns, which after processes and additives can affect the material properties of the yarns. It has also been found that if the yarn is pulled from individual packages, and unwound from the top of the cone or tube, the natural tendency of the yarn to twist as it proceeds through the needle loom amplifies the effectiveness of the needle penetration therethrough.

15 The present invention can use a straight, substantially horizontal, flat needle bed 19 (Fig. 4) or a curved needle bed (Fig. 3), such as used in a Fehrer H-1 needle loom. In the use of a curved needle bed, the yarns generally are subjected to about a 0° to 20° angle arc with respect to the needles (Fig. 4), although greater or lesser arcs also can be used as desired. The use of an arcuate bed tends to give a longer stroke of the needles through
20 the yarn and thus typically increases the effectiveness of the needles capturing and pulling fibers through the yarns for interlocking the core and sheath fibers. The needles, because of the curvature of the needle bed, penetrate at multiple angles to the arc, which

increases the fiber interlocking within the fibrous body of the yarns 10 as shown in Figs. 1 and 5A. This not only creases the effectiveness, but also accomplishes higher output speeds for yarns processed according to the present invention. Upon exiting the needle bed, the yarns proceed through the tensioning rollers 29 (Fig. 2 and 3) and then are either
5 taken up on individual tubes or cones 31 (Fig. 1) or grouped together on a warper or beam for further processing.

In addition, the milled grooves 23 of the needle plate further typically are milled to a depth sufficient, and have side walls 24 of a sufficient spacing, such that two or more yarns 10, 10' (Fig. 4) could be fed on top of one another with their centerlines 27 aligned
10 with each other and with a line of needles as indicated in Fig. 4. The penetration of the needles through both parallel yarns causes an intermixing of the fibers of the two yarns 10 and 10' so as to produce a composite yarn that has two yarns welded or joined along their axis. The resultant yarn has a greater surface area than if the two yarns had been
15 plied together (Figs. 5B – 5C). The present invention thus can be used to form welded yarns wherein yarns of different material types are attached or welded together, as opposed to being twisted together to form a multi-ply yarn, as shown in Fig. 5C. To weld the yarns, the yarns, i.e., a polypropylene with good wicking properties and a cotton yarn with good absorption, are laid one on top of the other in the yarn guide. As the needles punch through the yarns, they intermix and interlock the fibers to form a side-by-side
20 double strand yarn with each of the yarn components 10 and 10' (Fig. 5C) having more exposed surface area over a conventional twisted multi-ply yarn.

A further embodiment of the present invention is shown in Fig. 6. In this embodiment, as the yarns are moved through the needle loom, a fiber mass or fabric 40 can be incorporated with the yarns. The fiber mass generally will be formed from natural or synthetic fibers, or a combination thereof, and is fed in a blanket or sheet from a feed roll 41 along the feed path 14 of the looms, the fiber mass 40 will be fed between the needles and the yarns, with the yarns passing along the milled groves of the needle plate bed on which the fiber mass is moved. The yarns are guided into and along the grooved slots in the needle bed and controlled by their positive tension draft so as to maintain their alignment with the needles. As the needles penetrate and pass out of the fiber mass and yarns, the fibers of the mass 40 and the yarns 10 become intermixed and interlocked so as to produce a fabric with increased dimensional stability and desired properties. Additionally, the fabric mass 40 could be split, such as along dashed lines 42, to form separate fibrous strips 43. Each strip can then be incorporated with or become an integral part of the yarns, bringing different desirable properties and characteristics to the yarns.

Yet another example of the present invention is the advancement and perfection of engineered yarns. These yarns incorporate a core of slit film, multi-deniers/filaments or a textured filament made of polypropylene, nylon, polyester, aramid, rayon, acrylic, or polyethylene wrapped or sheathed with fibers of cotton, synthetics, or combinations thereof. These can be processed through the needle loom, the needles of which will penetrate the filament and entangle the wrapper fibers, so that they become a single entity and to substantially ensure that that the sheath fibers will not slide along the axis of the yarn.

The resultant yarns can be used for a variety of uses, such as for mops or making into mats for abrasive pads or other uses, and have increased strength and absorbency, while also exhibiting better abrasiveness and resistance to unraveling and releasing lint. Thus, the yarns can be provided with the finished appearance and properties of high end
5 yarns while being capable of being formed by less expensive spinning processes.

Example 1

Two yarns were manufactured for Example 1. In the first sample (No. 1), .60 cotton count open-end spun (OE) and Dref spun yarns consisting of 34% rayon, 33% polyester, and 33% cotton were formed. The rayon was a 3 denier X 2 inch fiber
10 manufactured by Lenzing Corporation. The polyester was a 1.5 denier X 1.5 inch length manufactured by KOSA. The cotton was of a mill waste blend with fibers ranging in length from 1 inch to 1/8 inch. These fibers were blended, carded, and open-end spun on a 130 mm rotor, Reiter spinning machine with a 4.0 twist multiple. Four ends were then parallel wound on a tube and twisted on an ICBT two for one twister with an S twist..

15 The second sample (No. 2) consisted of .60 cotton count Dref spun and open end spun yarns composed of mill waste cotton, with fiber lengths of 1 inch to 1/8 inch and being of a cotton polyester blend. The fibers were prepared as in the previous sample through blending and carding. The fibers were then fed into a Dref II spinning frame and spun with a Z twist comparable to the open-end spun yarn. The yarns were then plied as
20 before with an S twist.

Each type of yarn of each sample was then processed through a Fehrer H-1 needle loom. The yarns of Sample No. 1 were processed at a speed of approximately 40

meters/min with the needles being reciprocated at about 1300 revolutions/min to give a puncture rate of about 1365 needle punctures/meter. The needle bed was formed in an arch design, with the needles generally having a penetration depth of 10mm and being positioned at varying degrees of penetration about an arc of about +20 to 0 to -20. The preferred needle used was a Foster 15 X18 X36 X3RBAF .20 6-4B polished. The needles were arranged in the bed in a straight line and the yarn was guided into the H-1 needle loom by ceramic eyelets that directed the yarn into the milled grooves of the needle plate, which grooves kept the yarns positioned directly under the needles. The yarn was then rewound onto tubes.

10 The yarns of Sample No. 2 also were processed through a Fehrer H-1 needle loom at 60 meters/min. The needle bed revolutions was 1300/min. totaling 900 needle punches/meter. The same Foster needle was used, however the penetration depth was increased to 14mm.

A small reeling of each yarn was tied into a bundle having a total length of approximately five inches. One control yarn reeling with no needling, one of each of the Sample No. 1 OE and Dref yarns, and one each of the Sample No. 2 OE and Dref yarns were prepared. These samples and control yarns were then placed into the AATCC standard Kenmore washing machine with varying amounts of warm water and ½ cup of Tide household detergent. A different sampling was used for each test.

20

Wash test of control and Sample Nos. 1 and 2 needle punched OE and Dref spun mop yarns - July 6, 2000

7 minute agitation in washing machine, medium water level

	Sample	No.	color	results
	1. .60/4 OE spun	Control	yellow	complete unraveled/partial degradation
5	2. .60/4 OE spun	No. 1	orange	unravel .25 to .75 inch
	3. .60/4 OE spun	No. 2	teal	unravel 1 to 1.5 in
	A. .60/4 Dref spun	Control	none	unraveled and complete degradation
	B. .60/4 Dref spun	No. 1	black	0 to .25 inch unraveled
10	C. .60/4 Dref spun	No. 2	Lt. green	.25 to .5 inch unraveled

12-15 minute agitation in washing machine, medium water level

	Sample	No.	color	results
	1. .60/4 OE spun	Control	yellow	complete degradation
15	2. .60/4 OE spun	No. 1	orange	1 to 1.5 inch unraveled approx. ½ inch loss length
	3. .60/4 OE spun	No. 2	teal	unravel 1 to 1.5 inch
	A. .60/4 Dref spun	Control	none	complete unravel 2/3 loss of fiber
20	B. .60/4 Dref spun	No. 1	black	unravel .25 to .5 inch loss ½ to 1 inch in length
	C. .60/4 Dref spun	No. 2	Lt. green	unravel .25 to 1 inch no loss of length

15-20 minute HIGH agitation in washing machine, Low water level

	Sample	No.	color	results
25	1. .60/4 OE spun	Control	yellow	complete degradation, loss of ½ of fiber mass
	2. .60/4 OE spun	No. 1	orange	unravel .25 to 2 inch approx. ½ inch loss in length
30	3. .60/4 OE spun	No. 2	teal	unravel 1 to 2.5 inch , approx. ½ to 1 inch loss in length
	A. .60/4 Dref spun	Control	none	complete degradation, massive fiber loss
35	B. .60/4 Dref spun	No. 1	black	unravel .25 to 1 inch, approx. ½ to 1 inch in length
	C. .60/4 Dref spun	No. 2	Lt. green	unravel 1 to 2.5 inch, approx. ½ to ¾ inch loss in length

40

CONCLUSION:

The open-end spun yarns and Dref spun yarns processed by the present invention out performed the control, unprocessed, yarns with the open-end spun yarn samples exhibiting better resistance to unraveling than the Dref spun yarns. The Dref spun yarns processed with the present invention did, however, exhibit significantly greater
5 performance and resistance to unraveling and loss of fiber than the open-end yarns of the control sample.

EXAMPLE 2

A yarn of an open-end design was used, composed of 60% Lenzing 3 denier X 2
10 inch rayon fiber blended with 20% Kosa 2 denier X 2 inch polyester fiber and 20% Sterling 3 denier X 2 inch natural acrylic fiber. The yarns were processed through a fiber control opening line, Crosrol Mark 5 carding machine and spun on a 100mm rotor to a 1/1 cotton count yarn with a 4.0 twist multiple. Four identical ends were then parallel wound onto a tube and twisted on a Volkman 05 two for one twister.

15 A portion of this yarn was then processed through a Fehrer H-1 needle loom. The yarn was processed through the loom as before, and was contained within the grooves of the needle bed. The preferred needle was a Groz-Beckard 15x 18x38x3 222G. Because of the open-end yarn construction and the smaller size and total yarn mass as compared with Example One, a smaller gauge needle with a more aggressive barb structure was
20 preferred. The yarn traveled through the needling zone at about 10 meters per minute. This yielded an estimated approximately 5410 needle penetrations per meter of yarn with

the needles being reciprocated at about 1300 revolutions per minute at about a 13mm penetration depth.

Three reelings of before needling and after needling yarn samples were prepared. These measured approximately five inches in length and the yarns of each sample were cut at one end to resemble a cut-end mop. The sample reelings were then placed into a standard AATC Kenmore washing machine filled ½ full of warm water and one cup of Tide household detergent. The normal heavy washing agitator cycle was used.

minute agitation in washing machine, medium water level

Sample	Results
10 ¼ rayon blend without needling	yarn completely untwisted
¼ rayon blend with needling	no change in appearance

10 minute agitation in washing machine, medium water level

Sample	Results
15 ¼ rayon blend without needling	yarn untwisted, some fiber loss
¼ rayon blend with needling	no change in appearance

30 minute agitation in washing machine, medium water level

Sample	Results
20 ¼ rayon blend without needling	yarn untwisted, increasing fiber loss
¼ rayon blend with needling	no change in appearance

CONCLUSION:

25 The ¼ rayon blend yarn is the preferred yarn in the janitorial field for the application of floor finishes. This application, however, requires the mop to release little, if any lint. This test thus shows how the needling process of the present invention greatly improved the performance of this yarn in not only in the degree of linting but also increasing the life of the mop.

It will be understood by those skilled in the art that while the invention has been described above with reference to certain embodiments and examples, numerous changes, additions and modifications can be made and various equivalents substituted without departing from the spirit and scope of the invention as set forth in the following claims.

CLAIMS

1. A process for forming yarns having enhanced properties, comprising:
 - moving at least one yarn along a feed path;
 - maintaining the yarn under tension as it is moved along its feed path;
 - directing the yarn along a guide channel extending beneath and in alignment with a series of spaced needles aligned with the feed path;
 - aligning and maintaining the yarn in an orientation perpendicular to the needles with the yarn guides; and
 - penetrating the yarn substantially through a centerline thereof and intermixing fibers within the yarn to enmesh the fibers.

2. The process of claim 1 and wherein directing the yarn along a guide channel comprises moving a pair of yarns along the guide channel with the yarns positioned parallel to each other and with both yarns aligned with a line of needles positioned in spaced series and aligned along the feed path.

3. The process of claim 1 and further comprising penetrating the yarn along and at an angle with respect to the centerline of the yarn so that the needles achieve increased penetration of the yarn.

4. The process of claim 1 and wherein the yarns each include core fibers and sheath fibers about the core fibers such that as the needles penetrate and withdraw from the yarns, the core fibers and sheath fibers are intermixed.
5. The process of claim 2 and wherein one of the yarns is of a first material having certain desired properties and the other yarn is of a second, different material having other desired properties such that as the needles penetrate and intermix fibers of the yarns, a composite yarn is formed having the desired properties of both yarns.
6. The process of claim 1 and further comprising passing a fibrous mass adjacent the needles and yarn and penetrating the mass and yarn with the needles so as to intermix the fibers of the yarn with fibers of the mat.
7. The process of claim 1 and wherein directing the yarn along a yarn guide comprises moving the yarn about an arcuate feed path along a groove having sloped sides defining the guide channel, with the yarn engaging and being directed into a central portion of the channel guide by the sloped sides of the groove.

8. The process of claim 7 and further comprising positioning the needles along the guide channel in an arc corresponding to the arcuate feed path and penetrating the yarn with the needles at an angle of approximately 0° to about 20° .
9. A yarn comprised of a series of spun fibers consisting essentially of natural fibers, synthetic fibers or a combination of natural and synthetic fibers, and including at least one core fiber and at least one sheath fiber, wherein said core fiber and said sheath fiber are engaged by needles arranged to penetrate substantially through a centerline of the yarn so as to penetrate and engage said core and sheath fibers and cause said core and sheath fibers to intermix as the needles move therethrough to provide the yarn with enhanced resistance to unraveling.
10. The yarn of claim 9 and wherein the yarn comprises a composite yarn having a first yarn and a second yarn each consisting essentially of natural fibers, synthetic fibers or a combination thereof, the yarns positioned adjacent and parallel to each other such that the needles penetrate approximately through the center of both yarns so that the fibers of both yarns are intermixed to weld the yarns together to form the composite yarn.
11. The yarn of claim 10 and wherein the first and second yarns each have different material properties such that the composite yarn includes the different material properties of both yarns.

12. The yarn of claim 9 and wherein the core and sheath fibers each have different material properties to produce a composite yarn incorporating such different material properties.

1/2

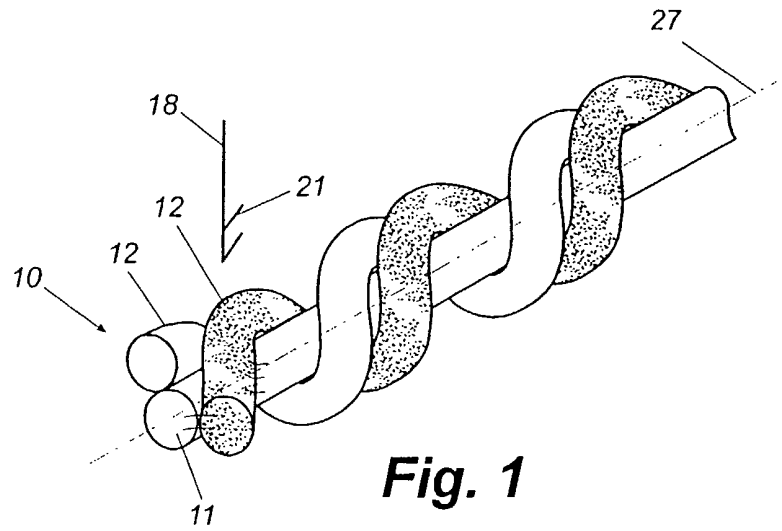

Fig. 1

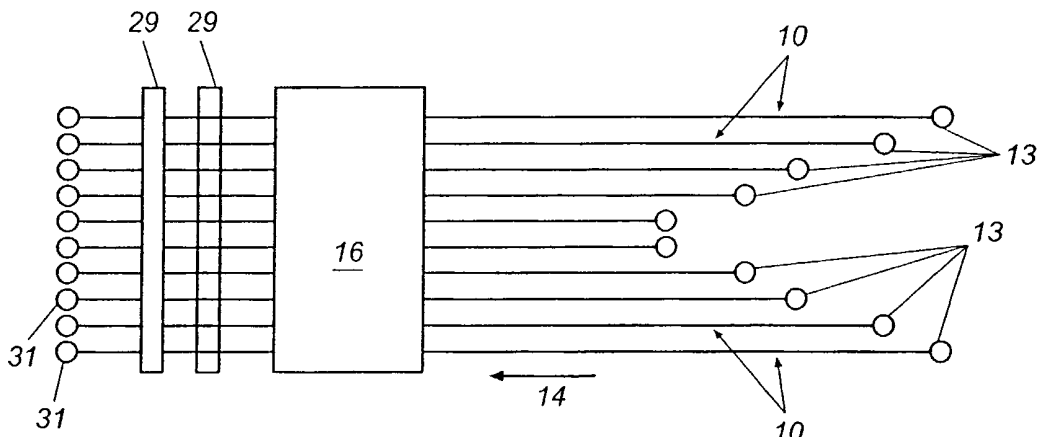

Fig. 2

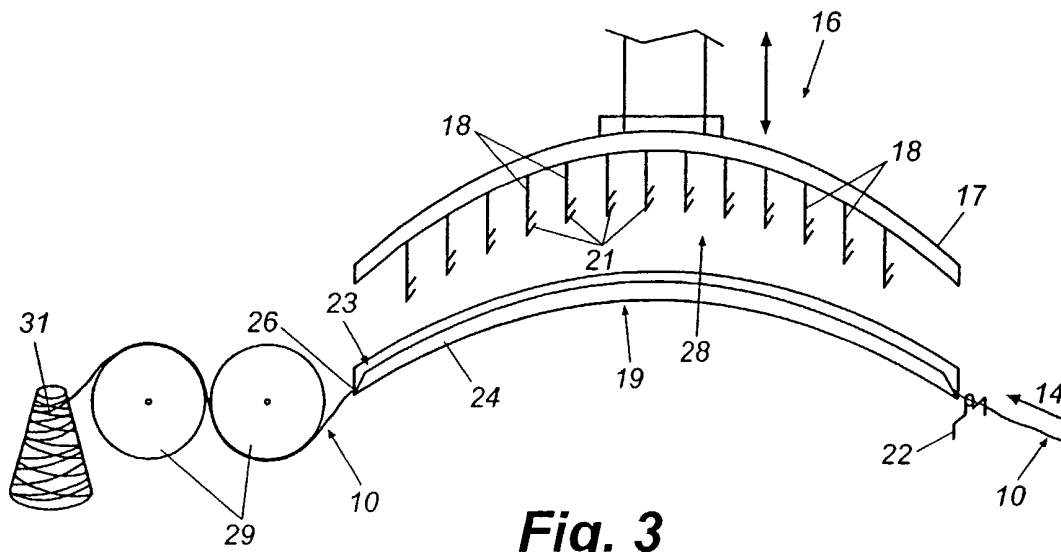

Fig. 3

2/2

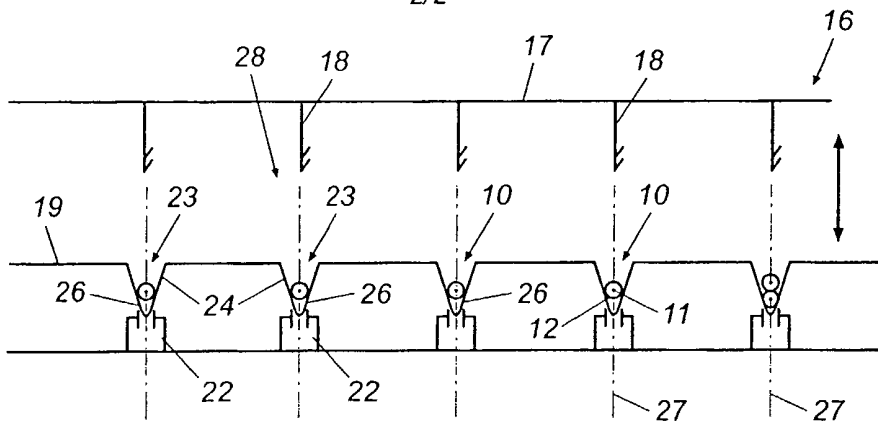

Fig. 4

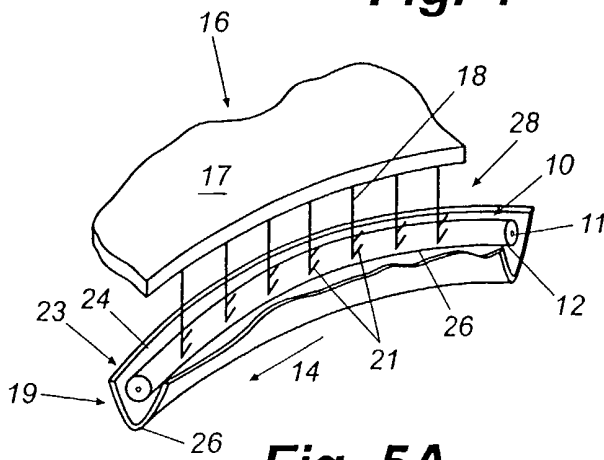

Fig. 5A

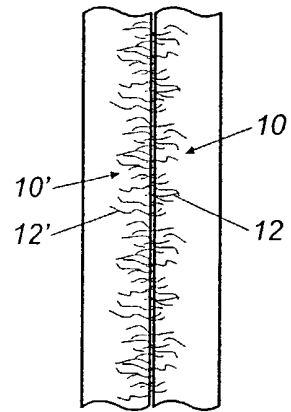

Fig. 5C

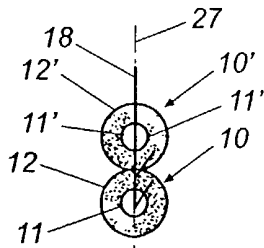

Fig. 5B

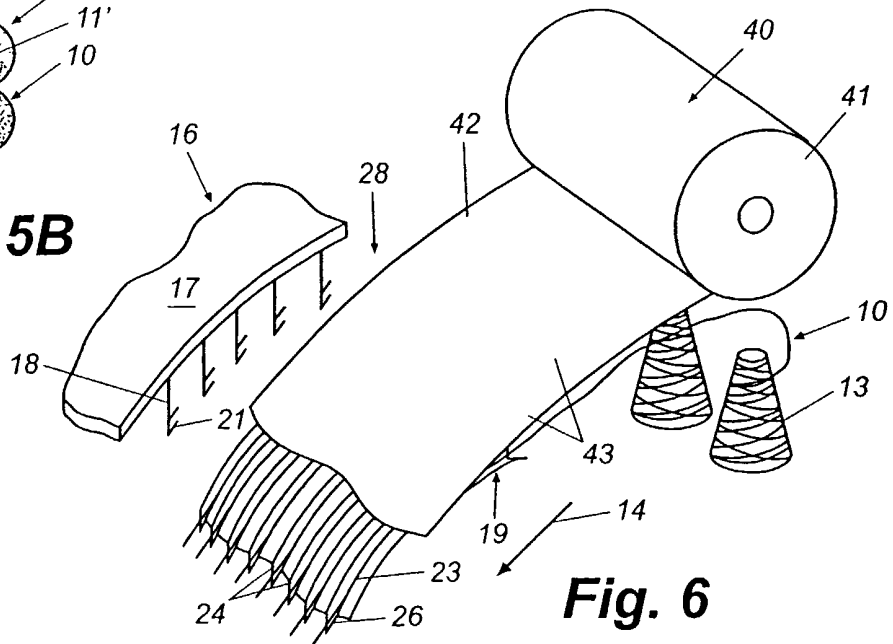

Fig. 6

INTERNATIONAL SEARCH REPORT

International application No.
PCT/US01/26392

A. CLASSIFICATION OF SUBJECT MATTER

IPC(7) :D02J 1/00

US CL :28/253, 247, 107, 115; 57/210

According to International Patent Classification (IPC) or to both national classification and IPC

B. FIELDS SEARCHED

Minimum documentation searched (classification system followed by classification symbols)

U.S. : Please See Extra Sheet.

Documentation searched other than minimum documentation to the extent that such documents are included in the fields searched

Electronic data base consulted during the international search (name of data base and, where practicable, search terms used)

EAST, seach terms: core, sheath, needled, needling, needl\$3

C. DOCUMENTS CONSIDERED TO BE RELEVANT

Category*	Citation of document, with indication, where appropriate, of the relevant passages	Relevant to claim No.
A	US 4,674,271 A (BIRD) 23 June 1987.	1-12
A	US 4,170,868 A (CHAMBLEY et al) 16 October 1979.	1-12
A	US 3,208,125 A (HALL et al) 28 September 1965.	1-12
A	US 5,081,753 A (FINK et al) 21 January 1992.	1-12
A	US 5,140,722 A (AKLYAMA) 25 August 1992.	1-12
A	US 5,375,311 A (NABULON) 27 December 1994.	1-12

Further documents are listed in the continuation of Box C.

See patent family annex.

• Special categories of cited documents	"I"	later document published after the international filing date or priority date and not in conflict with the application but cited to understand the principle or theory underlying the invention
"A" document defining the general state of the art which is not considered to be of particular relevance	"X"	document of particular relevance; the claimed invention cannot be considered novel or cannot be considered to involve an inventive step when the document is taken alone
"E" earlier document published on or after the international filing date	"Y"	document of particular relevance; the claimed invention cannot be considered to involve an inventive step when the document is combined with one or more other such documents, such combination being obvious to a person skilled in the art
"L" document which may throw doubts on priority claim(s) or which is cited to establish the publication date of another citation or other special reason (as specified)	"&"	document member of the same patent family
"O" document referring to an oral disclosure, use, exhibition or other means		
"P" document published prior to the international filing date but later than the priority date claimed		

Date of the actual completion of the international search

13 NOVEMBER 2001

Date of mailing of the international search report

31 DEC 2001

Name and mailing address of the ISA/US
Commissioner of Patents and Trademarks
Box PCT
Washington, D.C. 20231

Facsimile No. (703) 305-3230

Authorized officer

AMY VANATTA

Diane Smith f

Telephone No. (703) 308-0861

INTERNATIONAL SEARCH REPORT

International application No.

PCT/US01/26392

B. FIELDS SEARCHED

Minimum documentation searched

Classification System: U.S.

28/253, 247, 252, 277, 107, 108, 109, 110, 113, 114, 115, 278, 258, 219; 57/2, 90, 91, 206, 210, 207, 208, 225, 227,
243; 428/364, 365, 370, 371, 373, 374, 377, 399