



Europäisches Patentamt
European Patent Office
Office européen des brevets



(11) **EP 1 241 112 A3**

(12) **EUROPEAN PATENT APPLICATION**

(88) Date of publication A3:
26.02.2003 Bulletin 2003/09

(51) Int Cl.7: **B65D 81/32, B65D 75/00,
B65D 75/56**

(43) Date of publication A2:
18.09.2002 Bulletin 2002/38

(21) Application number: **01870157.3**

(22) Date of filing: **11.07.2001**

(84) Designated Contracting States:
**AT BE CH CY DE DK ES FI FR GB GR IE IT LI LU
MC NL PT SE TR**
Designated Extension States:
AL LT LV MK RO SI

(72) Inventors:
• **Etesse, Patrick Jean-François
1040 Brussels (BE)**
• **Degoix, Christophe Nicolas
1090 Brussels (BE)**

(30) Priority: **15.03.2001 EP 18700492**

(74) Representative:
**Morelle, Evelyne Charlotte Isabelle et al
N.V. Procter & Gamble Services Company S.A.
Temselaan 100
1853 Strombeek-Bever (BE)**

(71) Applicant: **THE PROCTER & GAMBLE COMPANY
Cincinnati, Ohio 45202 (US)**

(54) **Flexible multiple compartment pouch**

(57) The present invention relates to a flexible multiple compartment pouch (1), preferably capable of being used, when comprising compositions, to refill a multiple compartment durable container. In a preferred embodiment, the multiple compartment pouch (1) comprises a gripping means (7). In another preferred embodiment, the multiple compartment pouch (1) comprises at least one gusset (6). In yet another preferred embodiment, the multiple compartment pouch comprises at least a first and second compartment (2,3) wherein the first compartment (2) comprises a first composition and the second compartment (3) comprises a second composition and wherein the first and second compositions are incompatible.

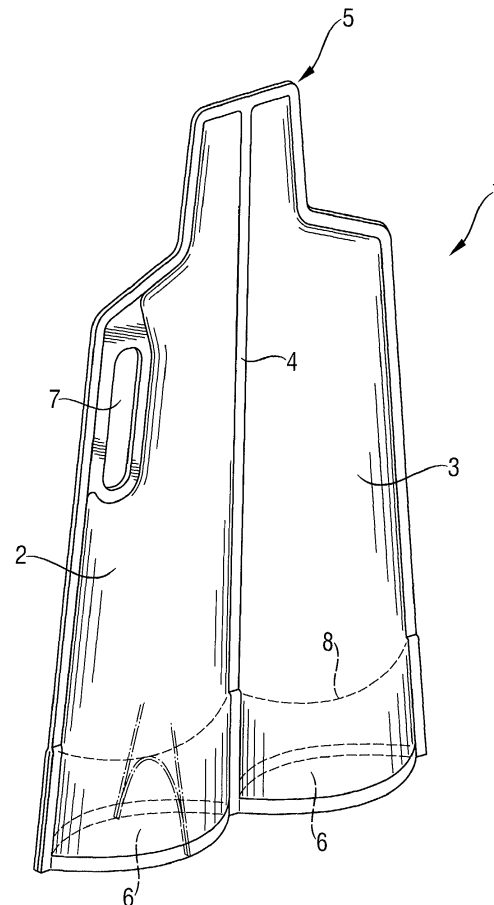

Fig. 1

EP 1 241 112 A3



European Patent Office

EUROPEAN SEARCH REPORT

Application Number
EP 01 87 0157

DOCUMENTS CONSIDERED TO BE RELEVANT

Category	Citation of document with indication, where appropriate, of relevant passages	Relevant to claim	CLASSIFICATION OF THE APPLICATION (Int.Cl.7)
X	JP 60 158007 A (TOYO SEIKAN) 19 August 1985 (1985-08-19) * figures 1-6 *	1	B65D81/32 B65D75/00 B65D75/56
X	JP 11 079203 A (UENO HIROSHI) 23 March 1999 (1999-03-23) * figures 15-19 *	1	
X	JP 09 240682 A (SEISAN NIPPONSHA KK) 16 September 1997 (1997-09-16) * figures 1-3 *	1	
X	DE 93 07 726 U (KLOCKE VERPACKUNGS-SERVICE) 29 July 1993 (1993-07-29) * page 2, line 5 - page 3, line 17; figures 1,2 *	1	
X	FR 2 669 304 A (BROVITEC AG) 22 May 1992 (1992-05-22) * page 6, line 1 - page 8, line 16; figures 1-4 *	1	
X	US 6 164 822 A (BEER JEFFREY SCOTT) 26 December 2000 (2000-12-26) * column 3, line 6 - column 4, line 55; figures 1-5 *	1	TECHNICAL FIELDS SEARCHED (Int.Cl.7) B65D
X	US 6 047 817 A (TAYLOR ANGELA ET AL) 11 April 2000 (2000-04-11) * column 2, line 25 - column 3, line 27; figures 1-7 *	1	
X	EP 1 010 642 A (REILLY DETLEV O ;SCHOMBERT JUERGEN DR (DE)) 21 June 2000 (2000-06-21) * column 2, line 53 - column 3, line 7; figures 1,2 *	1	

~~The present search report has been drawn up for all claims~~

Place of search MUNICH	Date of completion of the search 25 June 2002	Examiner Berrington, N
----------------------------------	---	----------------------------------

CATEGORY OF CITED DOCUMENTS

X : particularly relevant if taken alone
Y : particularly relevant if combined with another document of the same category
A : technological background
O : non-written disclosure
P : intermediate document

T : theory or principle underlying the invention
E : earlier patent document, but published on, or after the filing date
D : document cited in the application
L : document cited for other reasons

& : member of the same patent family, corresponding document

EPO FORM 1503 03/82 (P04C01)

**CLAIMS INCURRING FEES**

The present European patent application comprised at the time of filing more than ten claims.

- Only part of the claims have been paid within the prescribed time limit. The present European search report has been drawn up for the first ten claims and for those claims for which claims fees have been paid, namely claim(s):
- No claims fees have been paid within the prescribed time limit. The present European search report has been drawn up for the first ten claims.

LACK OF UNITY OF INVENTION

The Search Division considers that the present European patent application does not comply with the requirements of unity of invention and relates to several inventions or groups of inventions, namely:

see sheet B

- All further search fees have been paid within the fixed time limit. The present European search report has been drawn up for all claims.
- As all searchable claims could be searched without effort justifying an additional fee, the Search Division did not invite payment of any additional fee.
- Only part of the further search fees have been paid within the fixed time limit. The present European search report has been drawn up for those parts of the European patent application which relate to the inventions in respect of which search fees have been paid, namely claims:
- None of the further search fees have been paid within the fixed time limit. The present European search report has been drawn up for those parts of the European patent application which relate to the invention first mentioned in the claims, namely claims:

1



European Patent
Office

EUROPEAN SEARCH REPORT

Application Number
EP 01 87 0157

DOCUMENTS CONSIDERED TO BE RELEVANT			
Category	Citation of document with indication, where appropriate, of relevant passages	Relevant to claim	CLASSIFICATION OF THE APPLICATION (Int.Cl.7)
X	FR 2 793 220 A (OREAL) 10 November 2000 (2000-11-10) * figure 6 *	1	
X,P	FR 2 801 287 A (THIMONNIER SA) 25 May 2001 (2001-05-25) * page 4, line 11 - page 6, line 26; figures 1-3 *	1	
			TECHNICAL FIELDS SEARCHED (Int.Cl.7)
The present search report has been drawn up for all claims			
Place of search MUNICH		Date of completion of the search 25 June 2002	Examiner Berrington, N
CATEGORY OF CITED DOCUMENTS X : particularly relevant if taken alone Y : particularly relevant if combined with another document of the same category A : technological background O : non-written disclosure P : intermediate document		T : theory or principle underlying the invention E : earlier patent document, but published on, or after the filing date D : document cited in the application L : document cited for other reasons & : member of the same patent family, corresponding document	

EPO FORM 1503 03.82 (P04C01)



The Search Division considers that the present European patent application does not comply with the requirements of unity of invention and relates to several inventions or groups of inventions, namely:

1. Claim : 1

Flexible multiple compartment pouch comprising at least two compartments and a gusset

2. Claims: 2,4-6

Flexible multiple compartment pouch comprising at least two compartments containing different incompatible compositions.

3. Claims: 3,7-9,15,16

Flexible multiple compartment pouch comprising at least two compartments and a gripping means.

4. Claim : 10

Flexible multiple compartment pouch comprising at least two compartments whereby the additional compartments are located within the first.

5. Claims: 11-13,17

Flexible multiple compartment pouch comprising at least two adjacent compartments and further comprising adjacent outlets.

6. Claim : 14

Flexible multiple compartment pouch comprising at least two compartments whereby the outlets of each compartment converge to a connection device.

7. Claims: 18,19

Flexible multiple compartment pouch comprising at least two compartments whereby one compartment contains a liquid detergent.

8. Claim : 20

Flexible multiple compartment pouch comprising at least two compartments, the pouch comprising a sealable film and an aesthetic layer.



European Patent
Office

**LACK OF UNITY OF INVENTION
SHEET B**

Application Number
EP 01 87 0157

The Search Division considers that the present European patent application does not comply with the requirements of unity of invention and relates to several inventions or groups of inventions, namely:

9. Claim : 21

Method of refilling a durable container with a multiple compartment pouch.

**ANNEX TO THE EUROPEAN SEARCH REPORT
ON EUROPEAN PATENT APPLICATION NO.**

EP 01 87 0157

This annex lists the patent family members relating to the patent documents cited in the above-mentioned European search report. The members are as contained in the European Patent Office EDP file on
The European Patent Office is in no way liable for these particulars which are merely given for the purpose of information.

25-06-2002

Patent document cited in search report		Publication date	Patent family member(s)	Publication date
JP 60158007	A	19-08-1985	JP 1489796 C	07-04-1989
			JP 63040726 B	12-08-1988
JP 11079203	A	23-03-1999	NONE	
JP 09240682	A	16-09-1997	JP 3236987 B2	10-12-2001
DE 9307726	U	29-07-1993	DE 9307726 U1	29-07-1993
FR 2669304	A	22-05-1992	FR 2669304 A1	22-05-1992
US 6164822	A	26-12-2000	CA 2335170 A1	10-08-2001
			EP 1123875 A2	16-08-2001
US 6047817	A	11-04-2000	NONE	
EP 1010642	A	21-06-2000	DE 19857812 A1	21-06-2000
			EP 1010642 A1	21-06-2000
FR 2793220	A	10-11-2000	FR 2793220 A1	10-11-2000
			CA 2335905 A1	09-11-2000
			EP 1094976 A1	02-05-2001
			WO 0066455 A1	09-11-2000
FR 2801287	A	25-05-2001	FR 2801287 A1	25-05-2001