



- (51) **International Patent Classification:**
A61F 13/49 (2006.01) A61F 13/495 (2006.01)
A61F 13/494 (2006.01)
- (21) **International Application Number:**
PCT/US2014/067892
- (22) **International Filing Date:**
1 December 2014 (01.12.2014)
- (25) **Filing Language:** English
- (26) **Publication Language:** English
- (30) **Priority Data:**
61/919,067 20 December 2013 (20.12.2013) US
- (71) **Applicant: THE PROCTER & GAMBLE COMPANY** [US/US]; One Procter & Gamble Plaza, Cincinnati, Ohio 45202 (US).
- (72) **Inventors: MARTYNUS, Cornelia, Beate;** P&G Service GmbH, Sulzbacher Str. 40-50, 65824 Schwalbach (DE). **HECKER, Rolf;** P&G Service GmbH, Sulzbacher Str. 40-50, 65824 Schwalbach (DE). **FREIBOTH, Sandra;** P&G Service GmbH, Sulzbacher Str. 40-50, 65824 Schwalbach (DE). **MACURA, Anna, Elizabeth;** 1 Procter & Gamble Plaza, Cincinnati, Ohio 45202 (US). **GILLMAN, Elisa,**

Ann; 1 Procter & Gamble Plaza, Cincinnati, Ohio 45202 (US).

(74) **Agent: GUFFEY, Timothy B.;** c/o THE PROCTER & GAMBLE COMPANY, Global Patent Services, One Procter & Gamble Plaza, C8-229, Cincinnati, Ohio 45202 (US).

(81) **Designated States** (unless otherwise indicated, for every kind of national protection available): AE, AG, AL, AM, AO, AT, AU, AZ, BA, BB, BG, BH, BN, BR, BW, BY, BZ, CA, CH, CL, CN, CO, CR, CU, CZ, DE, DK, DM, DO, DZ, EC, EE, EG, ES, FI, GB, GD, GE, GH, GM, GT, HN, HR, HU, ID, IL, IN, IR, IS, JP, KE, KG, KN, KP, KR, KZ, LA, LC, LK, LR, LS, LU, LY, MA, MD, ME, MG, MK, MN, MW, MX, MY, MZ, NA, NG, NI, NO, NZ, OM, PA, PE, PG, PH, PL, PT, QA, RO, RS, RU, RW, SA, SC, SD, SE, SG, SK, SL, SM, ST, SV, SY, TH, TJ, TM, TN, TR, TT, TZ, UA, UG, US, UZ, VC, VN, ZA, ZM, ZW.

(84) **Designated States** (unless otherwise indicated, for every kind of regional protection available): ARIPO (BW, GH, GM, KE, LR, LS, MW, MZ, NA, RW, SD, SL, ST, SZ, TZ, UG, ZM, ZW), Eurasian (AM, AZ, BY, KG, KZ, RU, TJ, TM), European (AL, AT, BE, BG, CH, CY, CZ, DE, DK, EE, ES, FI, FR, GB, GR, HR, HU, IE, IS, IT, LT, LU,

[Continued on next page]

(54) **Title: DIAPER WITH IMPROVED SHAPE AND COMFORT**

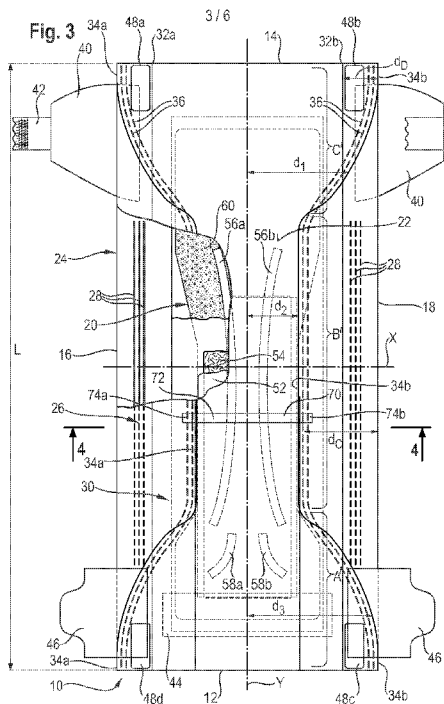

(57) **Abstract:** The invention relates to an infant or adult diaper. More particularly, the invention relates to an infant or adult diaper (10) having a longitudinal centerline (Y) and a lateral centerline (X) perpendicular to the longitudinal centerline (Y), wherein the diaper (10) comprises a topsheet (22) and a backsheet (24) and positioned therein between an absorbent core (20), and a first longitudinally extending elastic cuff (30a) and second longitudinally extending elastic cuff (30b), the first and the second elastic cuff (30a, 30b) being positioned on either longitudinal side of the topsheet (22) and opposing each other, and wherein the diaper (10) has a crotch region (B), positioned in between a front region (A) and a back region (C) and the first and the second longitudinally extending elastic cuff (30a, 30b) each have a crotch region (B'), positioned in between a front region (A') and a back region (C'), these regions of the longitudinally extending elastic cuffs (30a, 30b) being positioned in the respective regions of the diaper (10), and the first longitudinally extending elastic cuff (30a) and the second longitudinally extending elastic cuff (30b) each have a proximal edge (32a, 32b), at which the respective longitudinally extending elastic cuff is attached to the diaper and the the first longitudinally extending elastic cuff (30a) and the second longitudinally extending elastic cuff (30b) each have a distal edge (34a, 34b), at least the crotch region (B') of which is not attached to the diaper (10) and forms a free flap (38a, 38b) and wherein the diaper (10) comprises a transverse separator (70) being attached to the first longitudinally extending elastic cuff (30a) and the second longitudinally extending elastic cuff (30b), wherein each of the least one of longitudinally extending elastic cuffs (30a, 30b) has a distance to the longitudinal centerline (Y) at each point on the longitudinal centerline (Y) and wherein for at least one first longitudinally extending elastic cuff (30a) there is at least one first point on the longitudinal centerline (Y) where the distal edge (34) of the first longitudinally extending elastic cuff (30a) the has a first distance to longitudinal centerline (Y) and

there is at least one second point on the longitudinal centerline (Y) where the distal edge (34) of the first longitudinally extending elastic cuff (30a) the has a second distance to longitudinal centerline (Y) the and wherein the first distance is greater than the second distance when the diaper is in a flat position.



LV, MC, MK, MT, NL, NO, PL, PT, RO, RS, SE, SI, SK, **Published:**
SM, TR), OAPI (BF, BJ, CF, CG, CI, CM, GA, GN, GQ, — *with international search report (Art. 21(3))*
GW, KM, ML, MR, NE, SN, TD, TG).

DIAPER WITH IMPROVED SHAPE AND COMFORT

FIELD OF THE INVENTION

This invention is directed to diapers, including infant diapers, training pants, and adult
5 incontinence articles, and the like having an improved fit and leakage protection. In one aspect, the improved fit and leakage protection is achieved by a transverse separator connecting transversely opposite cuffs.

BACKGROUND OF THE INVENTION

10 Several diaper types have been proposed with components to improve fit and / or reduce leakage of feces and urine from the diaper, to reduce soiling of the genitals or other skin by the feces, or to reduce mixing of urine and feces, to further reduce the risk of irritation of the skin. For example, diapers with a topsheet with an opening, providing a passageway to a void space for collected feces and urine have been proposed; also proposed are diapers with two openings to
15 receive the urine and feces in separate areas; also proposed are diapers with a transversely positioned three-dimensional resilient barrier wall or partition placed in the centre of the diaper, to receive feces and urine respectively on either side of said wall or partition, and to avoid migration of the feces to the front of the article.

20 For example, EP 1 219 274 B1 (Tabata et al.) discloses a disposable absorbent article with at least one standing cuff. Such a standing cuff requires certain stretching members and therefore appear complex and costly in production.

25 EP 1 232 736 B1 (Toyoshima et al.) discloses an absorbent article with a pair of three-dimensional guards and a plurality of associated elastic members. Also there three-dimensional guards appear complex and costly in production. Further, they might comprise the wearing comfort of the absorbent article in some way and might make it more difficult for a caretaker to properly place the article on a wearer.

30 The inventors found however that, conventional cuffs and in particular relatively high conventional cuffs can be used in combination with certain cuff connections. When used with such

transverse separator even high cuffs provide a reliable leakage protection and are high wearing comfort.

SUMMARY OF THE INVENTION

The invention relates to an infant or adult diaper. More particularly, the invention relates to an infant or adult diaper (10) having a longitudinal centerline (Y) and a lateral centerline (X) perpendicular to the longitudinal centerline (Y), wherein the diaper (10) comprises a topsheet (22) and a backsheet (24) and positioned therein between an absorbent core (20), and a first longitudinally extending elastic cuff (30a) and second longitudinally extending elastic cuff (30b), the first and the second elastic cuff (30a, 30b) being positioned on either longitudinal side of the topsheet (22) and opposing each other, and wherein the diaper (10) has a crotch region (B), positioned in between a front region (A) and a back region (C) and the first and the second longitudinally extending elastic cuff (30a, 30b) each have a crotch region (B'), positioned in between a front region (A') and a back region (C'), these regions of the longitudinally extending elastic cuffs (30a, 30b) being positioned in the respective regions of the diaper (10), and the first longitudinally extending elastic cuff (30a) and the second longitudinally extending elastic cuff (30b) each have a proximal edge (32a, 32b), at which the respective longitudinally extending elastic cuff is attached to the diaper and the first longitudinally extending elastic cuff (30a) and the second longitudinally extending elastic cuff (30b) each have a distal edge (34a, 34b), at least the crotch region (B') of which is not attached to the diaper (10) and forms a free flap (38a, 38b) and wherein the diaper (10) comprises a transverse separator (70) being attached to the first longitudinally extending elastic cuff (30a) and the second longitudinally extending elastic cuff (30b), wherein each of the least one of longitudinally extending elastic cuffs (30a, 30b) has a distance to the longitudinal centerline (Y) at each point on the longitudinal centerline (Y) and wherein for at least the first longitudinally extending elastic cuff (30a) there is at least one first point on the longitudinal centerline (Y) where the distal edge (34) of the first longitudinally extending elastic cuff (30a) the has a first distance to longitudinal centerline (Y) and there is at least one second point on the longitudinal centerline (Y) where the distal edge (34) of the first longitudinally extending elastic cuff (30a) has a second distance to longitudinal centerline (Y) the and wherein the first distance is greater than the second distance when the diaper is in a flat position.

BRIEF DESCRIPTION OF THE DRAWINGS

Figure 1 shows a top view of a diaper in flat state suitable for being used with features of the present invention, but not embodying the present invention.

Figure 2 shows a cross-sectional view of the diaper of Figure 1 taken at the section line 2-2.

5 Figure 3 shows a top view of a diaper of the present invention in flat state.

Figure 4 shows a cross-sectional view of the diaper of Figure 3 taken at the section line 4-4.

Figure 5 (a,b,c) shows a schematic view of a diaper according to the present invention and prior art diapers.

Figure 6 shows a perspective view of the diaper of Figures 3 and 4.

10

DETAILED DESCRIPTION OF THE INVENTION

“Diaper” is used herein, to refer to absorbent articles to be placed about the wearer’s lower torso, and include infant (baby and toddler) diapers and adult diapers, and it includes so-called diapers with fasteners, to be fastened around the lower torso, and pant-type diapers.

15 “Front region” (A) and ‘back region’ (C) are used herein to refer to the two regions, which are in use, respectively, the closest to the front of the wearer and the back of the wearer, each spanning the transverse dimension of the diaper or diaper portion or element thereof, e.g. elastic cuff or topsheet, and each region having a longitudinal dimension that is (exactly or about or around) one fourth of the longitudinal dimension of the diaper or diaper portion or element thereof, e.g. elastic
20 cuff or topsheet.

“Crotch region” (B) is used herein to refer to the region positioned between the front region and the back region, having also a longitudinal dimension that is (exactly or about or around) one half of the longitudinal dimension of the diaper, diaper portion or element thereof, e.g. elastic cuff or
25 topsheet.

“Longitudinal” is used herein to refer to the direction which is running substantially parallel or exactly parallel to the longitudinal centerline (Y) of the diaper or diaper portion or topsheet, which may be the machine direction (MD) of the process.

30 When a diaper is provided with longitudinally extending elements, such as longitudinally extending elastic cuffs, these elements can each have a crotch region (B’), positioned in between a front region (A’) and a back region (C’), these regions of the longitudinally extending elements being generally positioned in or adjacent to the respective regions of the diaper.

“Lateral” or “transverse” is used herein to refer to the direction which is substantially perpendicular or exactly perpendicular to the longitudinal centerline (Y) of the diaper or diaper portion or topsheet, which may be the cross-machine direction of the process (CD).

5 “Z-direction” is used herein to refer to the direction perpendicular to the longitudinal direction and perpendicular to the transverse or lateral direction.

“Longitudinal dimension”, “transverse dimension” or “Z-dimension” is used herein to refer to the dimension of the diaper, diaper portion or element thereof, e.g. elastic cuff or topsheet, which is measured respectively in the longitudinal direction, transverse direction or Z-direction of the diaper or diaper portion or element thereof.

10 “Substantially perpendicular” or “substantially parallel” is used herein to refer to directions within 30° or 20° or 10° or 5° from the exact perpendicular or parallel direction, unless stated or specified otherwise.

As used herein, “along” means ‘at least partially substantially parallel to and adjacent to’.

15 “Relaxed” or “relaxed state” or “contracted” or “contracted state” is used herein to refer to the state of the diaper or diaper portion wherein no forces are applied to respectively the diaper or diaper portion.

“Flat state” is used herein to refer to the state of the diaper when the diaper is laid out flat onto an even horizontal surface.

20 “Distal edge” is used herein to refer to the longitudinally extending edge of an elastic cuff which in use is closer to the wearer’s body than the other longitudinally extending edge of the same elastic cuff.

25 A "nonwoven web" as used herein means a manufactured sheet, web or batt of directionally or randomly orientated fibers, bonded by friction, and/or cohesion and/or adhesion, excluding paper and products which are woven, knitted, tufted, stitch-bonded incorporating binding yarns or filaments, or felted by wet-milling, whether or not additionally needled. The fibers may be of natural or man-made origin and may be staple or continuous filaments or be formed in situ. Commercially available fibers have diameters ranging from less than about 0.001 mm to more than about 0.2 mm and they come in several different forms such as short fibers (known as staple, or chopped), continuous single fibers (filaments or monofilaments), untwisted bundles of continuous filaments (tow), and twisted bundles of continuous filaments (yam). Nonwoven webs can be formed by many
30 processes such as meltblowing, spunbonding, solvent spinning, electrospinning, carding and

airlaying. The basis weight of nonwoven webs is usually expressed in grams per square meter (g/m² or gsm).

The invention will be further explained with reference to the figures. Additionally, the invention will be explained with regard to certain of its features. The invention relates to a diaper comprising *inter alia* a topsheet, a backsheet, longitudinally extending elastic cuffs, referred to also as barrier leg cuffs, elastic waist features and a transverse separator. These elements will now first be described in some further detail.

10 Transverse separator

The transverse separator may have a transverse dimension in relaxed state of from 3.0 cm, or from 4.0 cm, or from 5.0 cm, to for example 15.0 cm, or to 10.0 cm, or to 8.0 cm or to 7.0 cm, or to 6.0 cm or to 5.5 cm. The transverse dimension is to be taken between attachment points, e.g. to the cuffs.

15 The transverse separator may have an average longitudinal dimension in relaxed state of at least 2.0 mm, or at least 4.0 mm, or at least 5.0 mm to less than 25.0 mm, 20.0 mm, 15.0 mm, 12.0 mm or less than 10.0 mm. The longitudinal dimension is to be taken over the longitudinal extension of attachment points, e.g. to the cuffs.

If the transverse separator comprises a top strip, the above longitudinal and transverse dimensions are those of that separator wall.

20 It is useful to position the transverse separator in the crotch area of the diaper, for example in the center thereof and a bit closer to the front region of the diaper. The distance from the front edge of the diaper to the edge of the transverse separator facing the front edge of the diaper may therefore be chosen to be 25% to 50% or 30 % to 45% of the total length of the diaper taken from the front edge to the rear edge of the diaper.

25 The transverse separator is elastically extensible in at least the transverse direction, i.e. is able to extend upon application of a force, and to contract to about its original width upon release of said force.

The transverse separator may also be elastically extensible in the longitudinal direction.

30 The transverse separator may be made of an elasticated sheet material, rendering the transverse separator elastically extensible in the transverse direction at least.

The transverse separator may comprise a separation wall being positioned above the top sheet and generally between longitudinally extending cuffs. The transverse separator may further comprise a top strip being positioned above the separation wall and generally between distal ends of such longitudinally extending cuffs. Both these elements can be provided individually from the materials mentioned herein for the transverse separator. Both elements can also be provided from the same material.

“Elasticated” when used herein for the transverse separator means that it is made of an inelastic sheet material that has been provided only in a specific area or in specific areas, i.e. the elasticated area(s), with an elastic material, e.g. one or more elastic bands or strands.

One or more portions of the transverse separator may be elasticated by application of one or more elastic band(s) or strand(s) extending substantially in transverse direction to a sheet material that may be inelastic e.g. an inelastic nonwoven sheet.

The nonwoven sheet material may be made of polyolefins known in the art, such as polyethylene and/or polypropylene, made into fibers, including bicomponent fibers that are then made into a nonwoven sheet. The nonwoven sheet material may be a necked nonwoven. The nonwoven sheet material may be a meltblown nonwoven or spunbond nonwoven or carded nonwoven; it may be a laminate thereof; for example it may be a laminate of spunbond or carded layer or layers and meltblown nonwoven layer(s).

The transverse separator material may be a barrier material; it may be hydrophobic; e.g. it may be hydrophilic and made hydrophobic with a hydrophobic surface coating, such as known in the art, for example a wax or a hydrophobic surface coating comprising one or more silicone polymers or fluorinated polymers. The transverse separator may also be treated with a lotion.

Attachment of the transverse separator sheet to the elastic cuffs

Parts of the transverse separator are attached to the elastic cuffs in the front, crotch region or rear region of the longitudinally extending elastic cuffs. A first cuff attachment area and a second cuff attachment area are formed by attaching respectively a first or second end portion of the transverse separator to an area of the longitudinally extending elastic cuffs.

The transverse separator has a top edge and a bottom edge, these are transversely extending opposing edges. These edges may be joined by two opposing side edges. The bottom edges can be used to connect the transverse separator to other parts of the absorbent article, for example to a

topsheet. The side edges may additionally or alternatively be used to connect the transverse separator to other parts of the absorbent article, for example to longitudinally extending cuffs, in particular to the barrier leg cuffs described below.

5 The attachment of the transverse separator to other portions of the diaper can be done by adhesive bonding, pressure bonding, ultrasonic bonding or any other attachment mean known in the art. A cuff attachment area may comprise one or more individual bond(s). Such individual bond(s) may be arranged according to a certain bonding pattern.

10 It should be understood that if an attachment area comprises more than one individual bond, these are herein considered as a single unitary cuff attachment area.

 The bonding pattern density of the first and/or second cuff attachment area(s) may be more than 20%, or more than 30%, or more than 40%, or more than 60%, up to 100%.

Barrier leg cuffs

15 The absorbent article comprises a pair of barrier leg cuffs, also referred to as longitudinally extending elastic cuffs. The barrier leg cuffs can be formed from a piece of material, typically a nonwoven, which is partially bonded to the rest of the article so that a portion of the material, the barrier leg cuffs, can be partially raised away and stand up from the plane defined by the topsheet when the article is pulled flat as shown e.g. in Fig. 3. The barrier leg cuffs can provide improved containment of liquids and other body exudates approximately at the junction of the torso and legs of the wearer. The barrier leg cuffs extend at least partially between the front edge and the back edge of the diaper on opposite sides of the longitudinal axis. The barrier leg cuffs are delimited by a proximal edge joined to the rest of the article, typically the topsheet and/or the backsheet, and a free distal edge, which is intended to contact and form a seal with the wearer's skin. The barrier leg cuffs are joined at the proximal edge with the chassis of the article by a bond which may be made for
20 example by gluing, fusion bonding or combination of known bonding means. The bond at the proximal edge may be continuous or intermittent. The side of the bond closest to the raised section of the leg cuffs delimits the proximal edge of the standing up section of the leg cuffs.

 The barrier leg cuffs can be integral with the topsheet or the backsheet, or more typically be formed from a separate material joined to the rest of the article. Typically the material of the barrier leg cuffs
30 may extend through the whole length of the diapers but is "tack bonded" to the topsheet towards the front edge and back edge of the article so that in these sections the barrier leg cuff material remains

flush with the topsheet. Alternatively or additionally, the material of the barrier leg cuffs may be bonded or “tack bonded” to another suitable layer and / or to itself. Each barrier leg cuff may comprise one, two or more elastic strings close to this free terminal edge to provide a better seal.

Each cuff may have an elastic tension of at least 20 grams (0.2N) and up to 100 grams
5 (1.0N), or up to 50 grams (0.5N), when extended to a 95% or 80% extension strain.

The cuffs or cuff web material may comprise a nonwoven sheet material. The same nonwoven sheet materials as the ones used to make the transverse separator may be used. The nonwoven sheet material may be a nonwoven barrier sheet material that is liquid impermeable, as
10 known in the art, including for example nonwoven laminate(s) with one or more spunbond layers and/or carded layers, and one or more meltblown layers. The fibers used to form the nonwoven sheet material may be selected from polypropylene fibers, polyethylene fibers, bicomponent fibers, nano-fibers and any combinations thereof.

The cuffs may have any suitable dimensions, for example depending on the diaper
15 dimensions. They may extend about the full length of the diaper. They may have a transverse dimension perpendicular to longitudinal centerline Y of the diaper of for example at least 30 mm, or for example at least 40 mm.

It is useful to provide a diaper according to the present invention, wherein the first point and the second point on the longitudinal centerline are both in front region of diaper and first point is closer to front edge than second point.

It is also useful to provide a diaper according to the present invention, wherein the first point and the second point on the longitudinal centerline are both in back region of diaper and first point is closer to rear edge than second point. The barrier leg cuffs then form a V-shape in the rear or back region of the diaper.

20 It is also useful to provide a diaper according to the present invention, wherein there is at least one third point on the longitudinal centerline where the distal edge of the first longitudinally extending elastic cuff the has a third distance to longitudinal centerline and and wherein the third distance is greater than the second distance when the diaper is in a flat position. It is beneficial, if the first point is in the front region of the diaper and the third point is in back region of diaper The barrier leg cuffs

then form a V-shape in the front region and in the rear region of the diaper. In other words, the barrier leg cuffs then form a double -V-shape.

Absorbent articles according to the present invention can be formed by folding the barrier leg cuffs upon themselves. The barrier leg cuffs have a first major surface and an opposing second major surface. In the crotch region the first surface is oriented towards a wearer and the second surface is oriented towards the article, e.g. the topsheet of the article. By folding the barrier leg cuffs upon
5 themselves in the front and / or the back region a portion of the first surface is folded onto an adjacent portion of the first surface. Thereby in the front and / or the back region a portion a portion of the second surface is oriented towards a wearer. Absorbent articles according to the present invention can also be formed by providing a z-fold in the barrier leg cuffs.

Absorbent articles according to the present invention can also be formed by using the barrier leg
10 cuffs having a different width between their proximal edge and their distal edge at different longitudinal positions. For example, the material used for providing the barrier leg cuffs may have a changing width in the lateral direction at different longitudinal positions.

It is also useful to provide a diaper according to the present invention, wherein the transverse separator is attached at the crotch region of the first longitudinally extending elastic cuff and is attached at the crotch region of the second longitudinally extending elastic cuff. The transverse separator can usefully connect the first longitudinally extending elastic cuff and the second longitudinally extending elastic cuff directly. The transverse separator does not need to be attached to portions of the diaper other than the first longitudinally extending elastic cuff and the second longitudinally extending elastic cuff . Usefully, the transverse separator can extend in a generally transverse direction and is able to exert a force between the first longitudinally extending elastic cuff and the second longitudinally extending elastic cuff, the force having a direction from one free flap towards the other free flap.

Usefully, the transverse separator can comprise a non-woven material or is made from a non-woven material. The transverse separator can comprise an elastic material or is made from an elastic material. The transverse separator can be made of or can comprise a laminate, which comprises an elastic material or a non-woven material.

In addition to the barrier leg cuffs, the article may comprise gasketing cuffs, which are joined to the chassis of absorbent article, in particular the topsheet and/or the backsheet and are placed transversely outwardly relative to the barrier leg cuffs. The gasketing cuffs can provide a better seal around the thighs of the wearer. Usually each gasketing leg cuff will comprise one or more elastic string or elastic element comprised in the chassis of the diaper for example between the topsheet and backsheet in the area of the leg openings.

US3,860,003 describes a disposable diaper which provides a contractible leg opening having a side flap and one or more elastic members to provide an elasticized leg cuff (a gasketing cuff).

US4,808,178 and US4,909,803 issued to Aziz et al. describe disposable diapers having "stand-up" elasticized flaps (barrier leg cuffs) which improve the containment of the leg regions. US4,695,278 and US4,795,454 issued to Lawson and to Dragoo respectively, describe disposable diapers having dual cuffs, including gasketing cuffs and barrier leg cuffs. All or a portion of the barrier leg and/or gasketing cuffs may be treated with a lotion.

15 Topsheet

The diaper comprises a topsheet.

It should be understood that the topsheet herein may be an individual topsheet or a topsheet that is part of a topsheet web, whereby such web is then subsequently divided into a multitude of individual topsheets. For the purpose of the invention, when referring to the topsheet, this shall include a topsheet web, respectively, unless stated otherwise. The same applies for the backsheet and absorbent core (that may be a backsheet web or absorbent core web), as referred to herein.

The topsheet of the diaper 1 herein may be made of any suitable material known in the art, provided it allows urine to pass. Hereto, it may be made of a urine permeable material, including hydrophilic material, or material treated to be hydrophilic. It may be an apertured topsheet which comprise apertures to allow urine to pass to the absorbent core under the topsheet;

The topsheet may be either hydrophilic or hydrophobic.

Preferred topsheet materials are nonwoven materials, including laminates and/or materials with apertures, such as apertured films, aperture formed films.

The topsheet, or for example only the crotch and/or back region thereof, may comprise a skin care composition, e.g. a lotion, as known in the art.

Fastening system

The absorbent article may include a fastening system. The fastening system can be used to provide lateral tensions about the circumference of the absorbent article to hold the absorbent article on the wearer as is typical for taped diapers. This fastening system is not necessary for training pant article
5 since the waist region of these articles is already bonded. The fastening system usually comprises a fastener such as tape tabs, hook and loop fastening components, interlocking fasteners such as tabs & slots, buckles, buttons, snaps, and/or hermaphroditic fastening components, although any other known fastening means are generally acceptable. A landing zone is normally provided on the front waist region for the fastener to be releasably attached. Some exemplary surface fastening systems
10 are disclosed in US 3,848,594, US4,662,875, US 4,846,815, US4,894,060, US4,946,527, US5,151,092 and US 5,221,274 issued to Buell. An exemplary interlocking fastening system is disclosed in US6,432,098. The fastening system may also provide a means for holding the article in a disposal configuration as disclosed in US 4,963,140 issued to Robertson et al.

The fastening system may also include primary and secondary fastening systems, as disclosed in
15 US4,699,622 to reduce shifting of overlapped portions or to improve fit as disclosed in US5,242,436, US5,499,978, US5,507,736, and US5,591,152.

As part of the fastening system, the absorbent article may comprise front ears and back ears as is known in the art. The ears can be integral part of the chassis, for example formed from the topsheet
20 and/or backsheets as side panel. Alternatively, they may be separate elements attached by gluing and/or heat embossing or pressure bonding. The back ears are advantageously stretchable to facilitate the attachment of the tabs on the landing zone and maintain the taped diapers in place around the wearer's waist. The back ears may also be elastic or extensible to provide a more comfortable and contouring fit by initially conformably fitting the absorbent article to the wearer and sustaining this
25 fit throughout the time of wear well past when absorbent article has been loaded with exudates since the elasticized ears allow the sides of the absorbent article to expand and contract.

Elastic waist feature

The absorbent article may also comprise at least one elastic waist feature (not represented) that helps to provide improved fit and containment. The elastic waist feature is generally intended to
30 elastically expand and contract to dynamically fit the wearer's waist. The elastic waist feature

preferably extends at least longitudinally outwardly from at least one waist edge of the absorbent core 28 and generally forms at least a portion of the end edge of the absorbent article. Disposable diapers can be constructed so as to have two elastic waist features, one positioned in the front waist region and one positioned in the back waist region. The elastic waist feature may be constructed in a number of different configurations including those described in US4,515,595, US4,710,189, US5,151,092 and US 5,221,274.

If should be noted, that the design (including the dimensions) of the cuffs, also the gasketing cuffs, and of the elastic waist feature and the fastening system has an influence on the overall fit of the diaper when worn and therefore on the position and functioning of the transverse separator. Where elastics are used in the various portions of the diaper, their elastic behaviour also has such an influence.

Relations between the layers

Typically, adjacent layers and components will be joined together using conventional bonding method such as adhesive coating via slot coating or spraying on the whole or part of the surface of the layer, or thermo-bonding, or pressure bonding or combinations thereof. This bonding is generally not represented in the Figures for clarity and readability but bonding between the layers of the article should be considered to be present unless specifically excluded. Adhesives may be typically used to improve the adhesion of the different layers, for example between the backsheet and the core wrap. The glue may be any standard hotmelt glue as known in the art.

Method of making the article

The absorbent articles of the invention may be made by any conventional methods known in the art. In particular the articles may be hand-made or industrially produced at high speed

Backsheet

The backsheet of the diaper may be liquid impervious, as known in the art. The liquid impervious backsheet preferably comprises a thin plastic film such as a thermoplastic film, for example having a thickness of about 0.01 mm to about 0.05 mm. Suitable backsheet materials comprise typically breathable material, which permit vapors to escape from the diaper while still preventing exudates from passing through the backsheet. Suitable backsheet films include those

manufactured by Tredegar Industries Inc. of Terre Haute, IN and sold under the trade names X15306, X10962 and X10964.

5 The backsheet, or any portion thereof, may be elastically extendable in one or more directions. The backsheet may be attached or joined to a topsheet, the absorbent core, or any other element of the diaper by any attachment means known in the art. It may be highly preferred that the longitudinal side edges of the topsheet and backsheet are directly attached to one another.

10 The essential elements of diaper 10, for which the present invention can be useful, are shown in Figures 1 and 2. Notably, the respective diaper does not already include the features of the present invention, however, serves to illustrate the benefits achievable by the present invention, once the invention is used for a diaper such as shown in Figure 1 and Figure 2.

15 The diaper 10 comprises a front edge 12 and a rear edge 14. The diaper also has a left side edge 16 and a right side edge 18.

20 For the purpose of absorbing liquids, the diaper comprises absorbent core 20. The absorbent core 20 is positioned between a topsheet 22 and a back sheet 24. The topsheet 22 is positioned on the wearer facing side of the diaper 10 and will allow, at least in one portion, the passage of liquids. The backsheet 24, however, is normally liquid proof (but may be vapor permeable).

25 The diaper 10 comprises gasketing cuffs 26, arranged on the wearer facing side, which is shown in the view of Figure 1. The gasketing cuffs 26 comprise elastics 28. These elastics 28 are normally arranged between topsheet 22 and backsheet 24. Alternatively, the elastics 28 can be provided between an extension sheet of the barrier leg cuffs 30 and the backsheet 24. The extension sheet can be joined to or integral with the barrier leg cuff(s). The elastics 28 can also be provided in the form of lines of elastic adhesives.

30 The diaper 10 also comprises barrier leg cuffs 30 (also referred to as "BLCs" or longitudinally extending cuffs). These barrier leg cuffs 30 are readily visible on the barrier facing side of the diaper, which is shown in the view of Figure 1. The barrier leg cuffs 30 exhibit a proximal edge 32 and a distal edge 34. The proximal edge 32 extends along the longitudinal direction of the diaper.

Typically, the barrier leg cuffs 30 are attached to the diaper 10 at least along their proximal edge 32. Normally, at least in the vicinity of front edge 12 and rear edge 14 further attachment areas are present. The barrier leg cuffs 30 also each have a distal edge 34, which also extends in the longitudinal direction.

5

The barrier leg cuffs 30 are equipped with elastics 36 positioned adjacent to distal edge 34. By means of these elastics 36, the barrier leg cuffs 30 can be brought in good contact with a wearer and will remain in contact with the wearer while the diaper 10 is worn. A portion of the barrier leg cuffs 30 is normally not attached to other portions of the diaper 10 and therefore forms a free flap 38. Such a free flap 38 is typically provided at least in the crotch portion B' of the barrier leg cuff 30. Typically, two longitudinally extending barrier leg cuffs are provided on either side of a diaper. As shown in Figure 1, these are barrier leg cuffs 30a and 30b. Each cuff has a respective proximal edge 32a, 32b and a respective distal edge 34a, 34b. Further, each cuff is provided with a free flap 38a, 38b. The barrier leg cuffs and in particular their free flaps 38a, 38b are provided in the form of mirror images and are centered about the longitudinal axis Y of the diaper.

10
15

The diaper 10 is also equipped with a fastening system. In the back region C of the diaper, the fastening system comprises back ears 40. The back ears 40 are provided with adhesive tapes 42. A landing zone 44 for the adhesive tapes 42 is provided in a region of the backsheet 24. When the diaper 10 is placed around the lower torso of a wearer, the back ears 40 co-operate with front ears 46. The front ears 46 comprise a tab portion.

20

Figure 2 provides a cross section view of the diaper as indicated by line 2-2 in Figure 1. This cross sectional view, provides more details about the structure of the core 20. Underneath topsheet 22, an acquisition distribution system 50 is provided. This system comprises an acquisition layer 52, which is placed adjacent to or in proximity of topsheet 22. Underneath the acquisition layer 52 a distribution layer 54, serving for the distribution of liquid, is arranged. Underneath the acquisition distribution system 50, core 20 is placed. As visible in this view, the core 20 comprises a number of channels 56. Also, several channels of different dimensions can be provided, such as further channel 58 as visible in Figure 1. Between such channels absorbent material 60 is arranged. The absorbent material 60 is covered by core wrap 62.

25
30

It is also readily visible from Figure 2, that dedicated attachment means are provided at the proximal edge 32 of the barrier leg cuff 30. As shown, this attachment means can be provided in the form of a barrier leg cuff bond 64. A respective bond can be provided by a longitudinally extending line of glue.

5

With regard to the diaper 10 shown in Figure 1 and Figure 2, which represents a modern diaper (not embodying the present invention), it has become apparent, that the distal edges 34a and 34b of the barrier cuffs 30 have a high degree of freedom of movement. The present invention has benefits in limiting this freedom of movement. This can lead to a better and more reproducible fit, especially in the crotch region.

10

Figure 3 provides a top plane view onto the barrier facing side of a diaper 10 according to the present invention. In the crotch region B of the diaper and thereby the crotch region B' of the barrier leg cuffs, a transverse separator 70 is arranged. The transverse separator 70 is provided in form of a separation wall 78 and a strip 72. The strip 72 is attached to each of the barrier leg cuffs 30a and 30b. A bottom portion of separation wall 78 is further attached to the topsheet 22. The attachment of strip 72 is achieved in attachment areas 74a and 74b. The transverse separator 70 limits the freedom of movement in particular of the free flaps 38a and 38b.

15

Further, another feature of the present invention is apparent in Figure 3. The distal edges 34a and 34b of the barrier leg cuffs 30a are not forming a straight line. Rather, in the front region A and in the back region C of the diaper the barrier leg cuffs are folded upon themselves. (It should be noted, that the back folding is more readily apparent in the three-dimensional view of Figure 6.)

20

Hence, the distal edges of the cuff have a variable distance to the center line Y of the diaper. For example, in the back region C of the diaper the distance measured at a first point on the longitudinal center line Y, is the distance d_1 . At a second point positioned more towards the center of a diaper, the distance between the distal edge of the barrier leg cuff 30b and the center line is d_2 . At a third point the distance between the longitudinal center line Y and the distal edge of the barrier leg cuff is d_3 .

25

30

In one embodiment, for achieving this variation of distance of the distal edge of the barrier leg cuff, the barrier leg cuff is folded over itself in the front and in the rear region. For the purpose of

maintaining such folding, the cuff bonding areas 48a, 48b, 48c and 48d are positioned close to the side edges of the diaper. The cuff bonding areas 48a and 48b are positioned in the rear area of the diaper and close to rear edge 14. The cuff bonding areas 48c and 48d are positioned in the front area of the diaper and close to front edge 12.

5

For example the cuff bonding area 48b is positioned at a relatively short distance d_D to the right side edge 18. This distance can be considerably shorter than the distance of the separator attachment area 74b to the right side edge 18, this distance being the distance d_C . (The distances d_C is to be taken towards the point of the separator attachment area 74b closest to the side edge and the distance d_D is to be taken towards the point of the cuff bonding area 48b most distant to the side edge.) Such an arrangement of attachment areas can further support the curvature of the leg cuffs.

10

However, there are different ways to arrive at such a curvature. For example, alternatively or additionally the extension of the leg cuff material in the lateral direction X can vary. Additionally or alternatively, different folding pattern can be used for the leg cuffs, for example double-folding, in particular in the form of z-folding.

15

It should be noted that the respective leg cuff arrangement has considerable advantages. It is already apparent from Figure 3, that the cuff does not cover a large area of the core. Especially in the front area and the rear area of the diaper free access to almost the full core is provided.

20

Figure 4 provides a cross sectional view taken along line 4-4 of Figure 3. In this cross sectional view it can readily be seen how transverse separator 70 (in particular strip 72) connects distal edge 34a of barrier leg cuff 30a with distal edge 34b of barrier leg cuff 30b. The attachment areas 74a and 74b are provided on the inner side of barrier leg cuff 30a and 30b, this is the side of the barrier leg cuffs generally facing the topsheet 22. The respective attachment area 74a and 74b are provided adjacent to the elastics 36. They could, however, also be provided in other areas of the barrier leg cuffs 30.

25

Figures 5a to 5c illustrate in schematic views some specific benefits of the present invention. Figure 5a shows a conventional diaper. Diaper 10 comprises a left side edge 16 and a right side edge 18. The diaper further comprises a left barrier leg cuff 30a and a right barrier leg cuff 30b. Both barrier

30

leg cuffs are bonded to the diaper 10 (for example its top sheet) at barrier leg cuff bonds 64. The barrier leg cuff bond 64 form lines extending in the longitudinal direction.

Typically the outer dimensions of the diaper 10 are defined by its top sheet and its back sheet. The core of the diaper covers the central region but does not extend over the full area of the top sheet and the back sheet. Hence, it is realistic to assume, that the core of the diaper covers the area extending between the two parallel barrier leg cuff bond lines 64.

It becomes clear therefore, that the conventionally positioned barrier leg cuffs 30a and 30b (represented by the edged areas) cover a certain portion of the core. The coverage may be less, when the diaper is not in the flat position as shown, however a certain coverage must be assumed.

For overcoming this disadvantage another diaper configuration can be considered. In such a configuration, the barrier leg cuffs are arranged differently. The barrier leg cuffs can again be bonded along longitudinally extending barrier leg cuff bond lines 64. The respective arrangement is shown in Figure 5b. The respective bond lines 64 can be positioned at the same distance as shown in Figure 5a. However, in the arrangement shown in Figure 5b the barrier leg cuffs are arranged differently as they extend outwardly from the respective bond lines 64. Thereby the barrier leg cuffs extend (fully or almost) to the left side edge 16 and to the right side edge 18. As it is apparent from Figure 5b, this arrangement provides better access to the core. Also when the diaper is worn, the leg cuffs are not in the way of any matter to be absorbed by the core. (In this regard it should be noted that in view of the gasketing task, the leg cuffs are typically provided from a liquid impermeable material.)

There is, however, a disadvantage associated with the arrangement shown in Figure 5b. When the diaper is worn, the actual position of the leg cuff will depend upon the anatomy of the wearer a lot. Further it can depend on the level of care which is used by a caretaker in placing the article. Therefore it can happen and has been observed to happen, that the barrier leg cuffs extend outward of the side edges of the diaper. This is an aesthetical disadvantage. Moreover, it should be noted that outward of the bond areas of the diaper leg cuff often further gasketing cuffs are used. These gasketing cuffs are typically positioned relatively close to the side edges of the diaper. In the arrangement of Figure 5b hence the barrier leg cuff can interfere with the gasketing cuffs. Indeed, if a

barrier leg cuff is caught between the wearers skin and a gasketing cuff, a potential point of leakage is created.

In the prior art the choice of either a diaper construction generally in line with Figure 5a or a diaper
5 construction generally in line with Figure 5b has to be made. The present invention overcomes this dilemma.

Figure 5c gives a schematic view of the present invention and its benefits. The figure shows a diaper
10 which is essentially of the same dimension as the diaper shown in Figure 5b. At the front end and at the rear end of the diaper, the barrier leg cuffs extend outwardly from the bond lines 64. They reach the respective side edges of the diaper.

However, the arrangement of the barrier leg cuffs in the central portion of the diaper is considerably
different. By using transverse separator 70, the barrier leg cuffs and thereby also the side edges are
15 pulled together. It should be noted, that transverse separator 70 makes a connection between the distal edges of the barrier leg cuffs. Hence the distal edges go inward from the very corners of the diaper to attachment points with the transverse separator 70 and then go outward again to the very corners of the diaper.

20 Thereby the two leg cuffs essentially assume a double-V shape. This shape ensures that high access to the core is given and that the leg cuffs do not interfere with material to be absorbed. It should be noted that material to be absorbed will typically reach the diaper either in the front region or in the rear region. It is therefore of essential benefit to have open and free access to the core.

25 This benefit can be achieved without compromising good fit and liquid protection of the diaper. Transverse separator 70 ensure that the barrier leg cuffs are pulled inward and their distal edges cannot extend outward of the left side edge 16 or the right edge 18 of the diaper.

Figure 6 provides a perspective view of the diaper 10 according to the present invention. The diaper
30 10 is shown in a non-flat configuration. This configuration at least in part approximates the configuration which the diaper assumes when being worn. The figure illustrates more accurately the position which is taken by the barrier leg cuffs in such configuration. At the rear end C of the diaper

10 both barrier leg cuffs are folded upon themselves. Hence, a fold over area 76 is provided. A similar fold over area is provided in the front area A, but is less readily visible in this view.

5 It is also visible in this configuration that the barrier leg cuffs 30a and 30b stand up above the topsheet 22. Thereby, the free flaps 38a and 38b have a high freedom of movement. To a certain extend, this freedom of movement is limited by the elastics 36 (as shown in Fig. 3 and 4). However, the transverse separator 70 provides in an efficient way a further limitation of the freedom of movement. The transverse separator 70 assumes a position which is defined by an equilibrium of several forces, which can be carefully designed and influenced. These forces include those exerted
10 by the barrier leg cuffs 30a and 30b, by the elastics 36 of these cuffs and by the transverse separator 70 itself.

The dimensions and values disclosed herein are not to be understood as being strictly limited to the exact numerical values recited. Instead, unless otherwise specified, each such dimension is
15 intended to mean both the recited value and a functionally equivalent range surrounding that value. For example, a dimension disclosed as “40 mm” is intended to mean “about 40 mm”.

Every document cited herein, including any cross referenced or related patent or application, is hereby incorporated herein by reference in its entirety unless expressly excluded
20 or otherwise limited. The citation of any document is not an admission that it is prior art with respect to any invention disclosed or claimed herein or that it alone, or in any combination with any other reference or references, teaches, suggests or discloses any such invention. Further, to the extent that any meaning or definition of a term in this document conflicts with any meaning or definition of the same term in a document incorporated by reference, the meaning or definition
25 assigned to that term in this document shall govern.

While particular embodiments of the present invention have been illustrated and described, it would be obvious to those skilled in the art that various other changes and modifications can be made without departing from the spirit and scope of the invention. It is
30 therefore intended to cover in the appended claims all such changes and modifications that are within the scope of this invention.

CLAIMS

What is claimed is:

1. An infant or adult diaper (10) having a longitudinal centerline (Y) and a lateral centerline (X) perpendicular to the longitudinal centerline (Y), wherein the diaper (10) comprises a topsheet (22) and a backsheet (24) and positioned therein between an absorbent core (20), and a first longitudinally extending elastic cuff (30a) and second longitudinally extending elastic cuff (30b), the first and the second elastic cuff (30a, 30b) being positioned on either longitudinal side of the topsheet (22) and opposing each other, and wherein the diaper (10) has a crotch region (B), positioned in between a front region (A) and a back region (C) and the first and the second longitudinally extending elastic cuff (30a, 30b) each have a crotch region (B'), positioned in between a front region (A') and a back region (C'), these regions of the longitudinally extending elastic cuffs (30a, 30b) being positioned in the respective regions of the diaper (10), and the first longitudinally extending elastic cuff (30a) and the second longitudinally extending elastic cuff (30b) each have a proximal edge (32a, 32b), at which the respective longitudinally extending elastic cuff is attached to the diaper and the the first longitudinally extending elastic cuff (30a) and the second longitudinally extending elastic cuff (30b) each have a distal edge (34a, 34b), at least the crotch region (B') of which is not attached to the diaper (10) and forms a free flap (38a, 38b) and wherein the diaper (10) comprises a transverse separator (70) being attached to the first longitudinally extending elastic cuff (30a) and the second longitudinally extending elastic cuff (30b), wherein each of the least one of longitudinally extending elastic cuffs (30a, 30b) has a distance to the longitudinal centerline (Y) at each point on the longitudinal centerline (Y) and wherein for at least the first longitudinally extending elastic cuff (30a) there is at least one first point on the longitudinal centerline (Y) where the distal edge (34) of the first longitudinally extending elastic cuff (30a) the has a first distance to longitudinal centerline (Y) and there is at least one second point on the longitudinal centerline (Y) where the distal edge (34) of the first longitudinally extending elastic cuff (30a) the has a second distance to longitudinal centerline (Y) the and wherein the first distance is greater than the second distance when the diaper is in a flat position.

2. An infant or adult diaper (10) according to claim 1, wherein the first point and the second point are both in front region (A) of diaper and first point is closer to front edge (12) than second point.
3. An infant or adult diaper (10) according to claim 1 or 2, wherein the first point and the second point are both in back region (C) of diaper and first point is closer to rear edge (14) than second point.
4. An infant or adult diaper (10) according to any one of the preceding claims, wherein there is at least one third point on the longitudinal centerline (Y) where the distal edge (34) of the first longitudinally extending elastic cuff (30a) has a third distance to longitudinal centerline (Y) and wherein the third distance is greater than the second distance when the diaper is in a flat position.
5. An infant or adult diaper (10) according to claim 4, wherein the first point is in the front region (A) of the diaper and the third point is in back region (C) of diaper.
6. The diaper (10) according to any one of the preceding claims, wherein at least one longitudinally extending elastic cuff (30a, 30b) is folded upon itself.
- 5 7. The diaper (10) according to any one of the preceding claims, wherein at least one longitudinally extending elastic cuff (30a, 30b) has a different width between their proximal edge and their distal edge at different longitudinal positions
8. The diaper (10) according to claim 1, wherein the transverse separator (70) is attached at the crotch region (B') of the first longitudinally extending elastic cuff (30a) and is attached at the crotch region (B') of the second longitudinally extending elastic cuff (30b).
9. The diaper (10) according to any one of the preceding claims, wherein the transverse separator (70) extends in a generally transverse direction and is able to exert a force between the first longitudinally extending elastic cuff (30a) and the second longitudinally extending elastic cuff (30b), the force having a direction from one free flap (38a) towards the other free flap (38b).

10. The diaper (10) according to any one of the preceding claims, wherein the transverse separator (70) is attached to at least one of the longitudinally extending elastic cuffs by means of an adhesive.
11. The diaper (10) according to any one of the preceding claims, wherein the transverse separator (70) comprises a separation wall (78).
12. The diaper (10) according to the preceding claim, wherein the transverse separator (70) comprises a strip (72) positioned at the top edge of the separation wall (78).
13. The diaper (10) according to claim 9 or 10, wherein the transverse separator (70) is provided in the form of a comprises a separation wall (78) and a strip (72).
14. The diaper (10) according to claim 10 or 11, wherein the strip has a width, as measured in the longitudinal direction of the diaper (10), from about 2 mm to about 25 mm.
15. The diaper (10) according to any one of the preceding claims, wherein the transverse separator (70) comprises an elastic material or is made from an elastic material.

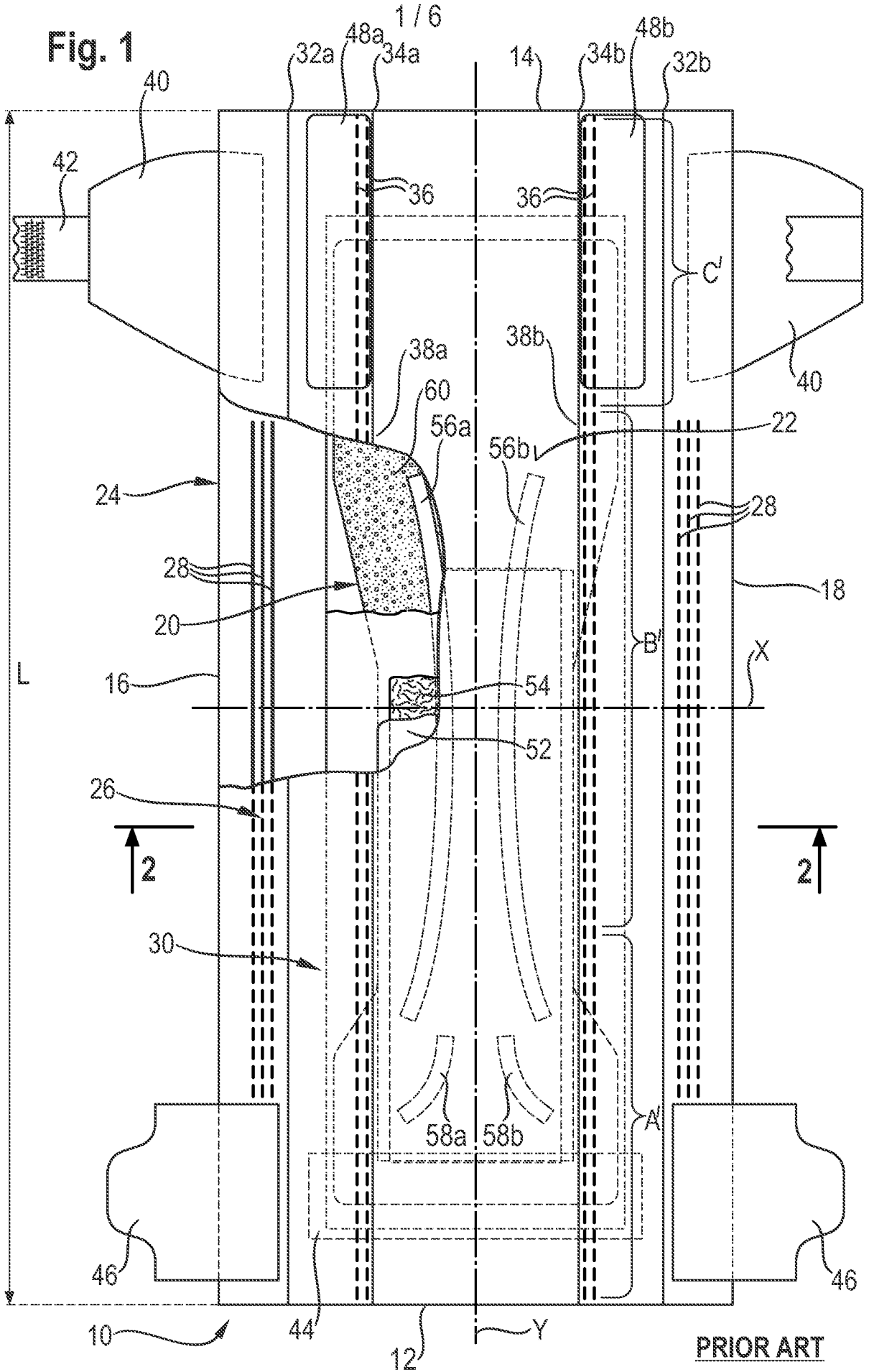
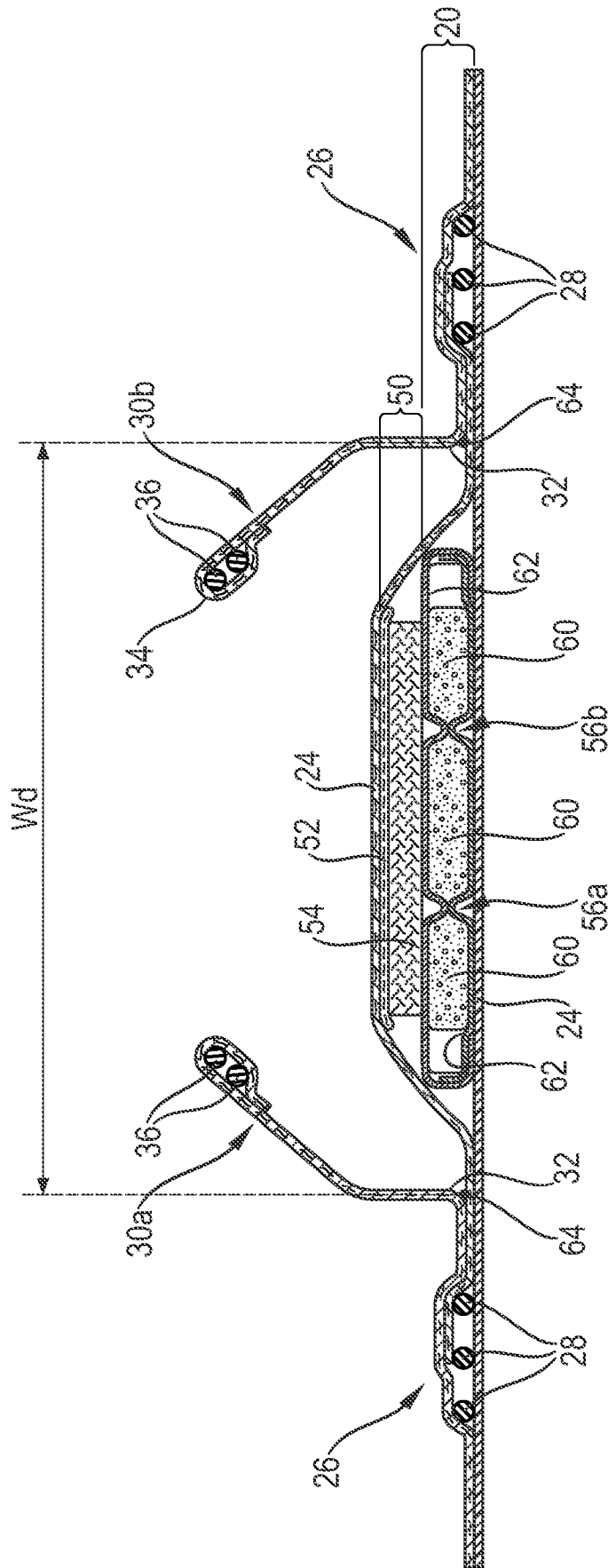

Fig. 2



PRIOR ART

Fig. 3

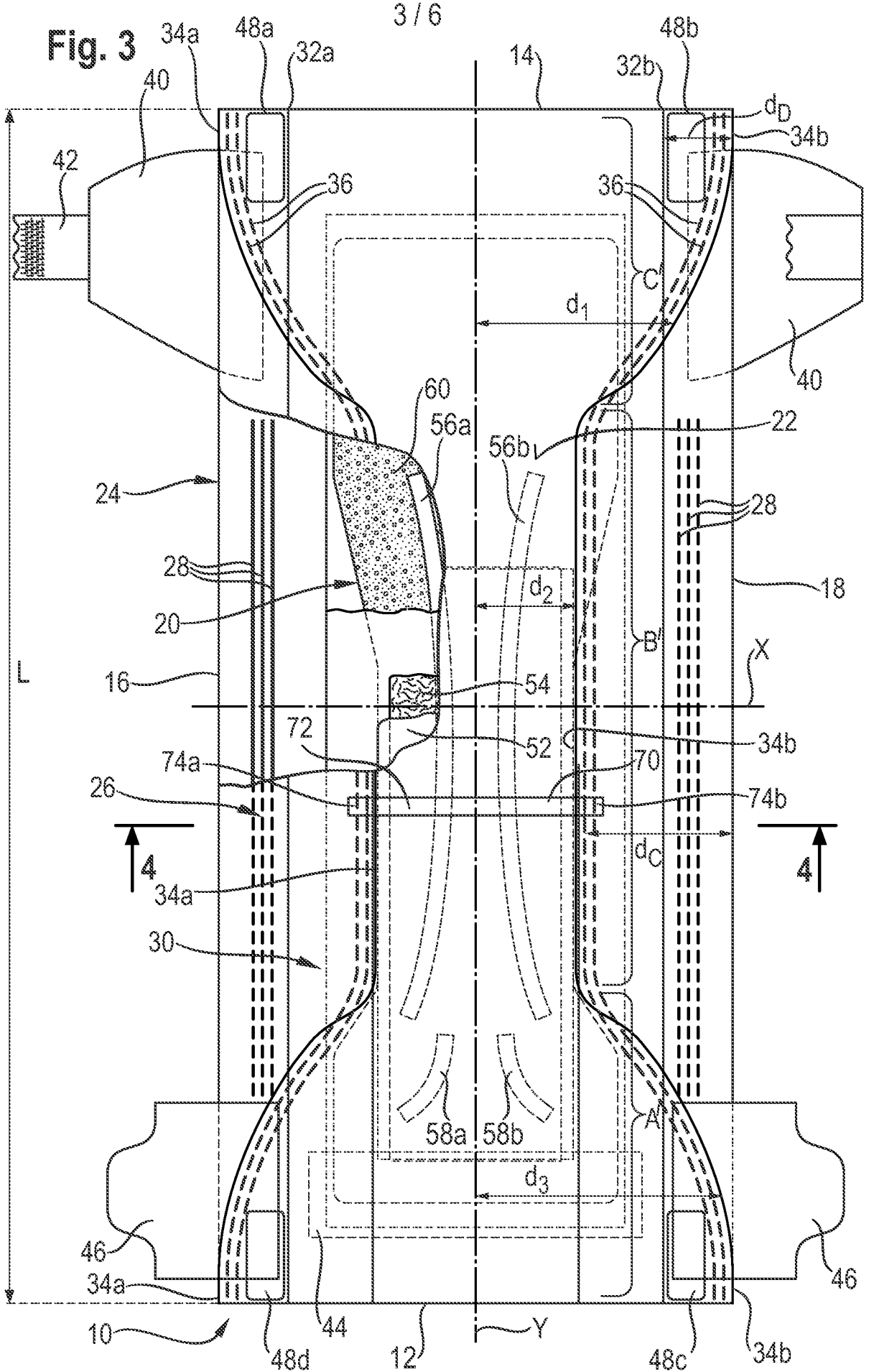

Fig. 4

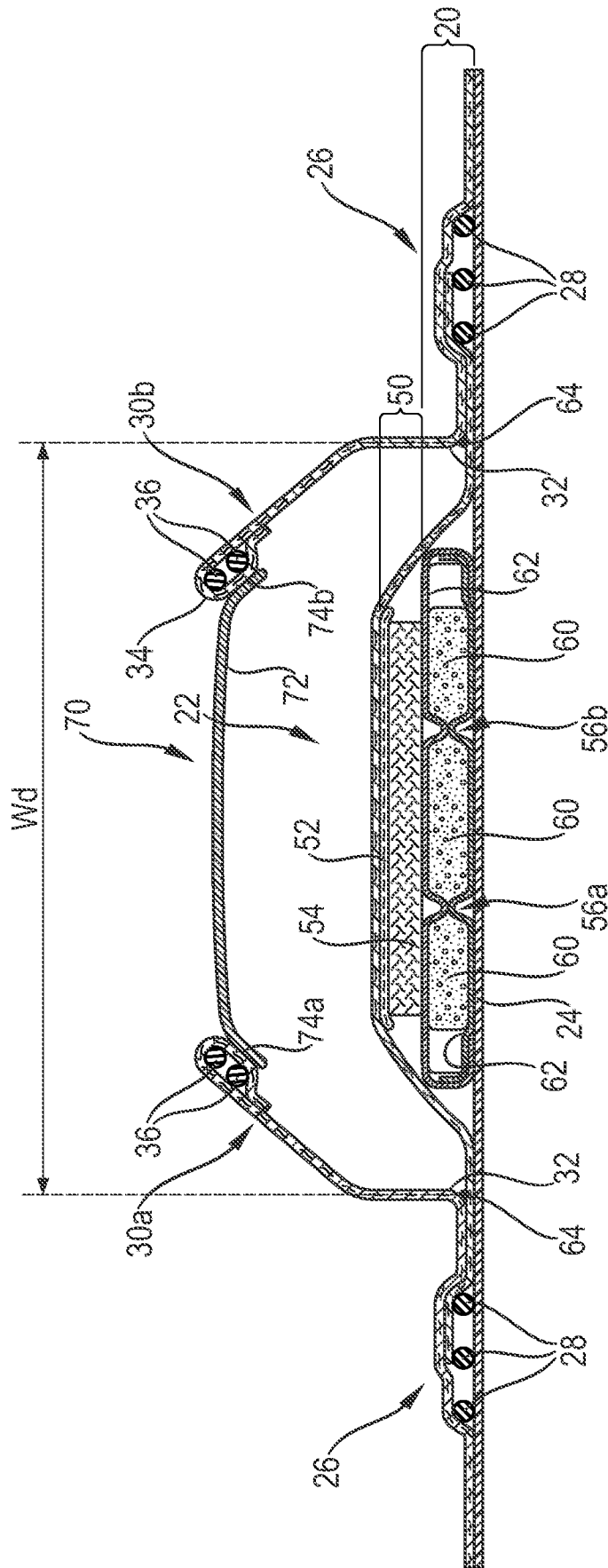

Fig. 5a

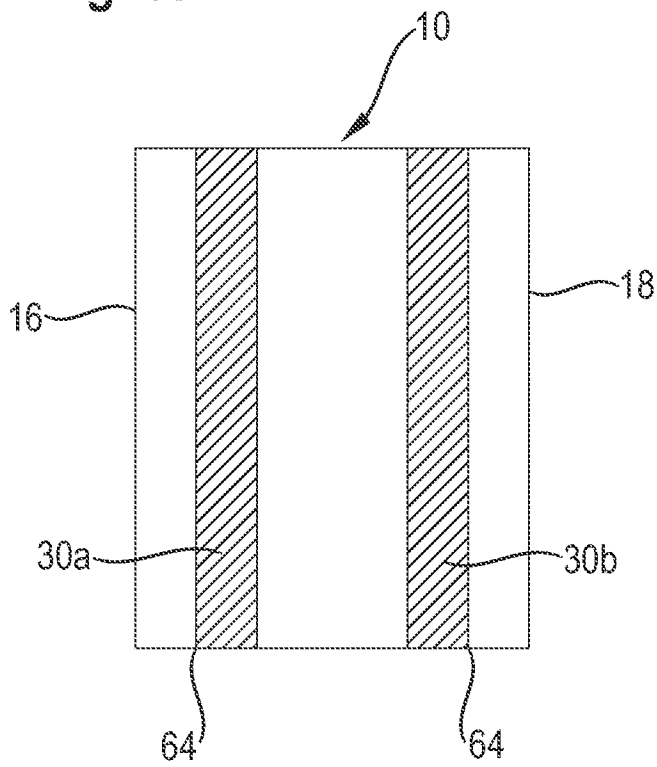

Fig. 5b

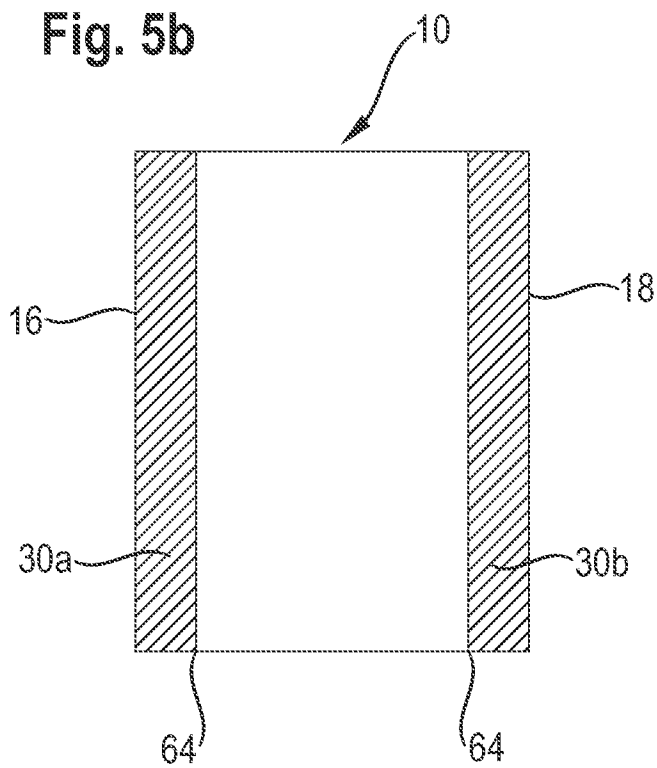
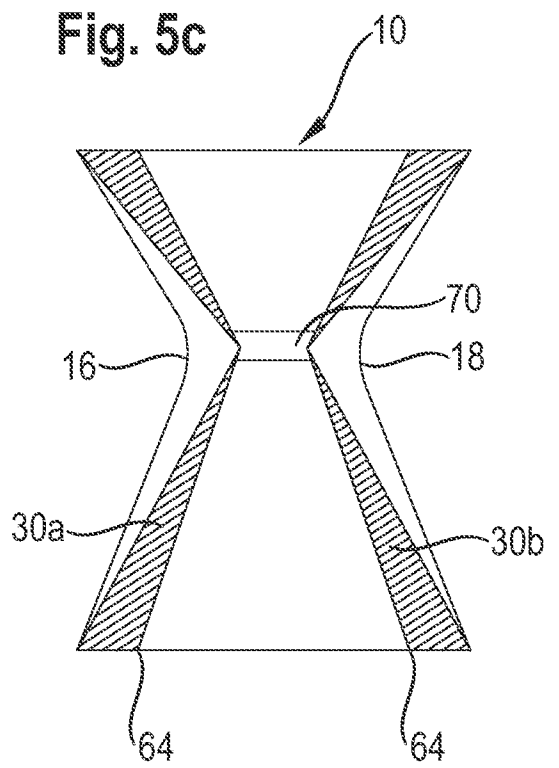

Fig. 5c



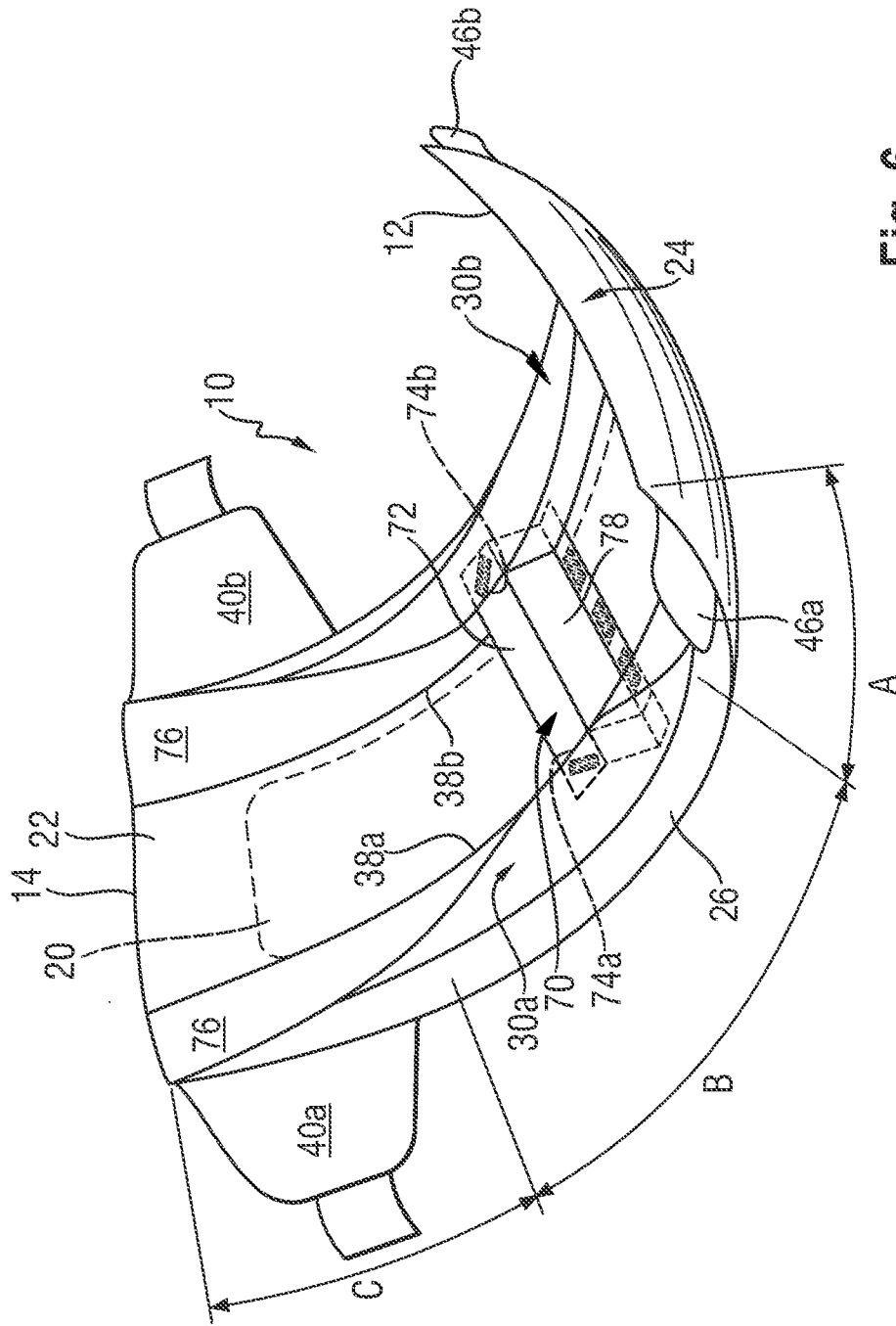

Fig. 6

INTERNATIONAL SEARCH REPORT

International application No
PCT/US2014/067892

A. CLASSIFICATION OF SUBJECT MATTER
INV. A61F13/49 A61F13/494 A61F13/495
ADD.
According to International Patent Classification (IPC) or to both national classification and IPC

B. FIELDS SEARCHED
Minimum documentation searched (classification system followed by classification symbols)
A61F

Documentation searched other than minimum documentation to the extent that such documents are included in the fields searched

Electronic data base consulted during the international search (name of data base and, where practicable, search terms used)
EPO-Internal, WPI Data

C. DOCUMENTS CONSIDERED TO BE RELEVANT

Category*	Citation of document, with indication, where appropriate, of the relevant passages	Relevant to claim No.
X	US 2006/135931 A1 (SUZUKI SACHIYO [JP] ET AL) 22 June 2006 (2006-06-22) figures 1,12 page 1, paragraph 1 page 1, paragraph 6 - page 2, paragraph 16 page 4, paragraph 45-47 page 5, paragraph 50 page 6, paragraph 61	1-15
X	WO 94/14395 A1 (PROCTER & GAMBLE [US]) 7 July 1994 (1994-07-07) page 1, lines 7-9 page 3, lines 13-27 page 8, line 34 - page 9, line 37 page 10, lines 24-31 page 11, lines 5-29 page 11, line 34 - page 12, line 6 figures 1,4	1-15

Further documents are listed in the continuation of Box C.

See patent family annex.

* Special categories of cited documents :

- "A" document defining the general state of the art which is not considered to be of particular relevance
- "E" earlier application or patent but published on or after the international filing date
- "L" document which may throw doubts on priority claim(s) or which is cited to establish the publication date of another citation or other special reason (as specified)
- "O" document referring to an oral disclosure, use, exhibition or other means
- "P" document published prior to the international filing date but later than the priority date claimed

"T" later document published after the international filing date or priority date and not in conflict with the application but cited to understand the principle or theory underlying the invention

"X" document of particular relevance; the claimed invention cannot be considered novel or cannot be considered to involve an inventive step when the document is taken alone

"Y" document of particular relevance; the claimed invention cannot be considered to involve an inventive step when the document is combined with one or more other such documents, such combination being obvious to a person skilled in the art

"&" document member of the same patent family

Date of the actual completion of the international search 2 March 2015	Date of mailing of the international search report 11/03/2015
---	--

Name and mailing address of the ISA/ European Patent Office, P.B. 5818 Patentlaan 2 NL - 2280 HV Rijswijk Tel. (+31-70) 340-2040, Fax: (+31-70) 340-3016	Authorized officer Beins, Ulrika
--	-------------------------------------

INTERNATIONAL SEARCH REPORT

 International application No
 PCT/US2014/067892

C(Continuation). DOCUMENTS CONSIDERED TO BE RELEVANT		
Category*	Citation of document, with indication, where appropriate, of the relevant passages	Relevant to claim No.
X	US 2007/156110 A1 (THYFAULT KEVIN [US]) 5 July 2007 (2007-07-05) page 1, paragraph 10 page 2, paragraph 21-24 figure 1 -----	1-15
X	US 2006/009746 A1 (NAKAJIMA KAIYO [JP] ET AL) 12 January 2006 (2006-01-12) figures 1,5 page 1, paragraph 5 page 1, paragraph 9 - page 2, paragraph 10 page 4, paragraph 47-49 page 6, paragraph 64 page 8, paragraph 78 -----	1,4-15
A	WO 98/53779 A1 (MOELNLYCKE AB [SE]; JOENBRINK ANNA KARIN [SE]) 3 December 1998 (1998-12-03) figures 1-14 -----	1-15

INTERNATIONAL SEARCH REPORT

Information on patent family members

International application No

PCT/US2014/067892

Patent document cited in search report	Publication date	Patent family member(s)	Publication date
US 2006135931	A1	22-06-2006	CA 2587964 A1 29-06-2006
			CN 101083969 A 05-12-2007
			EP 1829514 A1 05-09-2007
			JP 2006174966 A 06-07-2006
			KR 20070085784 A 27-08-2007
			MY 139829 A 30-10-2009
			TW I295169 B 01-04-2008
			US 2006135931 A1 22-06-2006
			WO 2006067992 A1 29-06-2006

WO 9414395	A1	07-07-1994	AT 169208 T 15-08-1998
			AU 691481 B2 21-05-1998
			AU 5746994 A 19-07-1994
			BR 9307674 A 08-09-1999
			CA 2149126 A1 07-07-1994
			CN 1090163 A 03-08-1994
			CZ 9501534 A3 17-01-1996
			DE 69320204 D1 10-09-1998
			DE 69320204 T2 21-01-1999
			DK 0674499 T3 02-11-1998
			EG 20197 A 30-10-1997
			EP 0674499 A1 04-10-1995
			ES 2119156 T3 01-10-1998
			FI 953007 A 16-06-1995
			GR 3027596 T3 30-11-1998
			HK 1012943 A1 23-06-2000
			HU 218519 B 28-09-2000
			JP 3375635 B2 10-02-2003
			JP H08504637 A 21-05-1996
			MA 23055 A1 01-07-1994
			MY 131375 A 30-08-2007
			NO 952363 A 15-06-1995
			NZ 259229 A 26-01-1998
			SG 63580 A1 30-03-1999
			TR 27778 A 09-08-1995
			TW 297766 B 11-02-1997
			US 6010490 A 04-01-2000
			WO 9414395 A1 07-07-1994

US 2007156110	A1	05-07-2007	NONE

US 2006009746	A1	12-01-2006	CN 1984627 A 20-06-2007
			EP 1767176 A1 28-03-2007
			JP 4791362 B2 12-10-2011
			KR 20070024714 A 02-03-2007
			MY 138454 A 30-06-2009
			TW I272940 B 11-02-2007
			US 2006009746 A1 12-01-2006
			US 2009234316 A1 17-09-2009
			WO 2006006539 A1 19-01-2006

WO 9853779	A1	03-12-1998	AT 250914 T 15-10-2003
			AU 733992 B2 31-05-2001
			AU 7679898 A 30-12-1998
			DE 69818697 D1 06-11-2003
			DE 69818697 T2 12-08-2004
			EP 1017345 A1 12-07-2000
			JP 2002501417 A 15-01-2002

INTERNATIONAL SEARCH REPORT

Information on patent family members

International application No

PCT/US2014/067892

Patent document cited in search report	Publication date	Patent family member(s)	Publication date
		NZ 501717 A	31-08-2001
		PL 336985 A1	31-07-2000
		RU 2207836 C2	10-07-2003
		TR 9902912 T2	21-07-2000
		US 6409711 B1	25-06-2002
		WO 9853779 A1	03-12-1998
<hr/>			