



US 20090177203A1

(19) **United States**

(12) **Patent Application Publication**  
**Reiley**

(10) **Pub. No.: US 2009/0177203 A1**

(43) **Pub. Date: Jul. 9, 2009**

(54) **DEVICES, SYSTEMS AND METHODS FOR RE-ALIGNMENT OF BONE**

(22) Filed: **Jan. 4, 2008**

**Publication Classification**

(75) Inventor: **Mark A. Reiley, Piedmont, CA (US)**

(51) **Int. Cl.**  
*A61F 5/00* (2006.01)  
*A61B 17/80* (2006.01)  
*A61B 17/04* (2006.01)

Correspondence Address:  
**RYAN KROMHOLZ & MANION, S.C.**  
**POST OFFICE BOX 26618**  
**MILWAUKEE, WI 53226 (US)**

(52) **U.S. Cl. .... 606/87; 606/280; 606/301**

(57) **ABSTRACT**

A bone re-angling device may be used in performing an osteotomy. The re-angling device may be a generally wedge-shaped body. The re-angling device maybe coupled to the bone using a fixation member.

(73) Assignee: **InBone Technologies, Inc.**

(21) Appl. No.: **12/006,720**

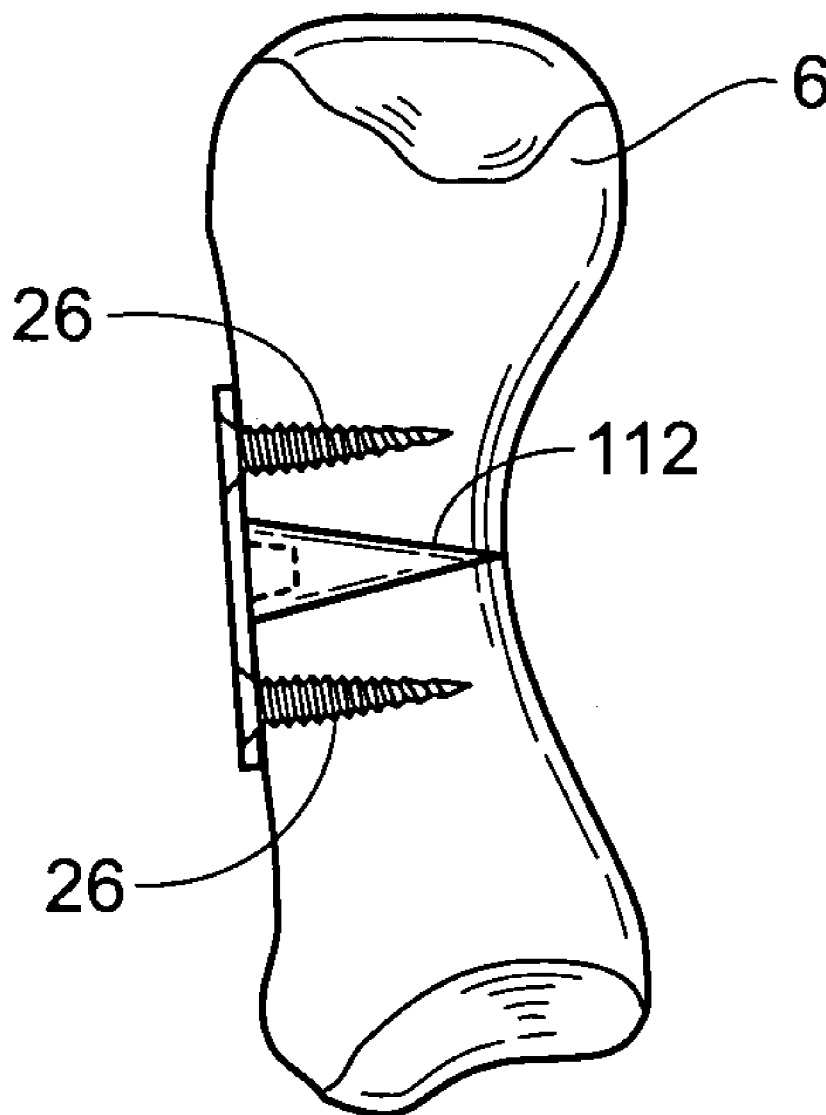

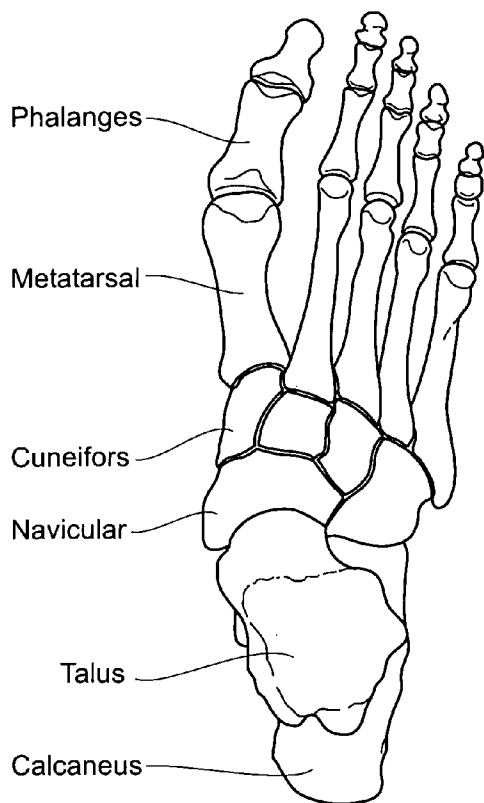

Fig. 1

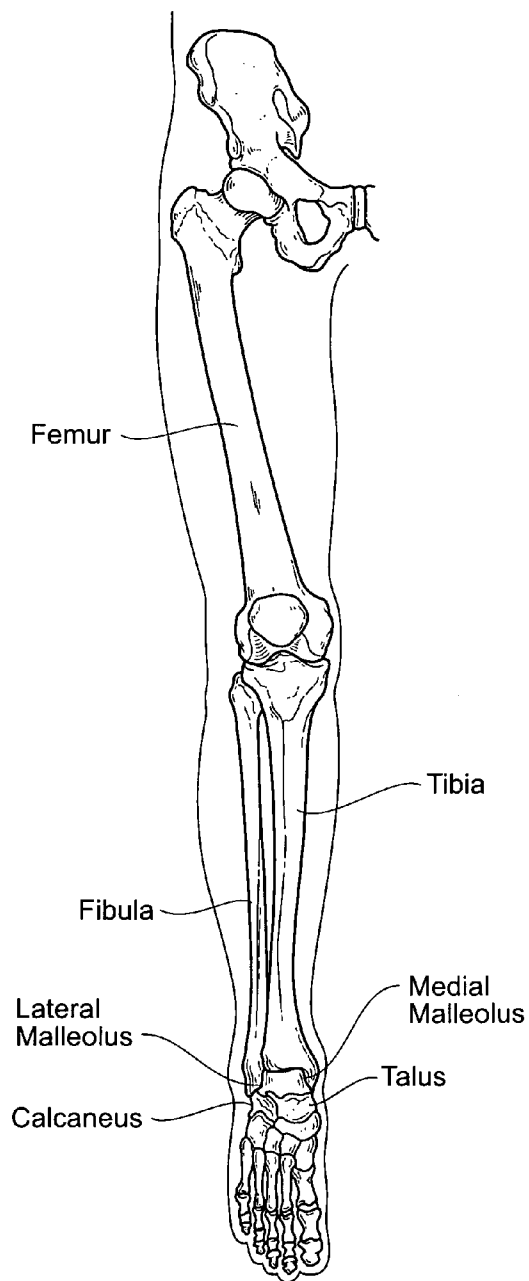

Fig. 2

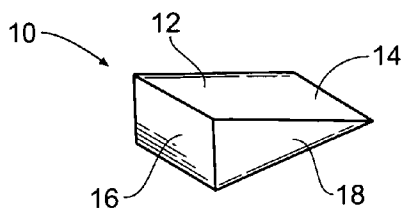

Fig. 3

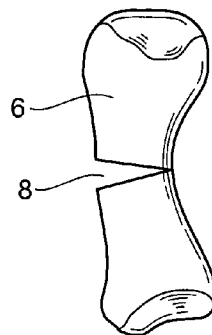

Fig. 4A

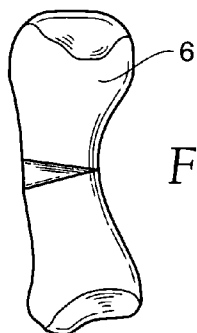

Fig. 4B

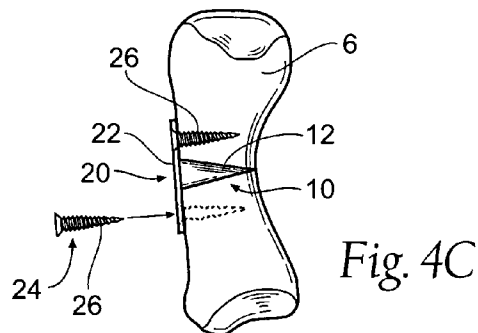

Fig. 4C

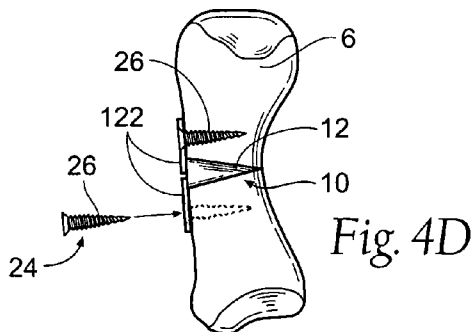

Fig. 4D

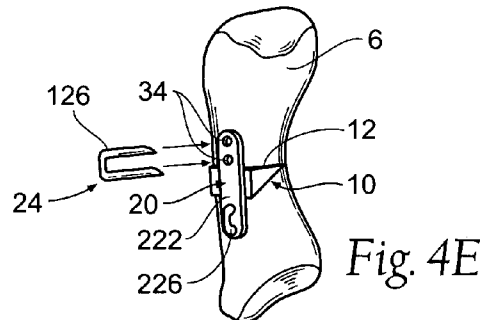

Fig. 4E

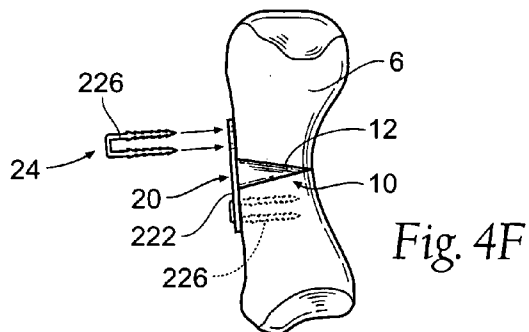
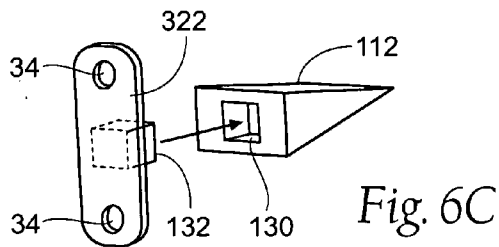
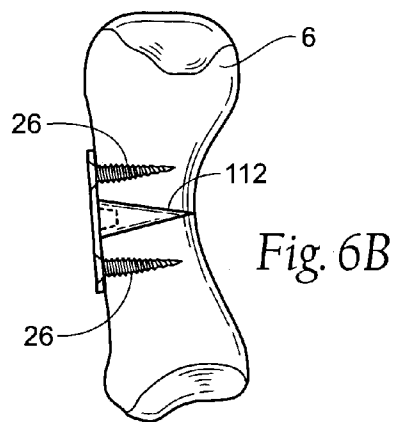
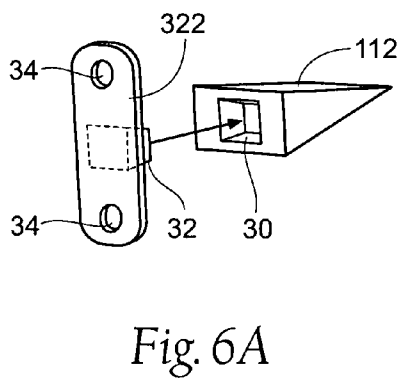
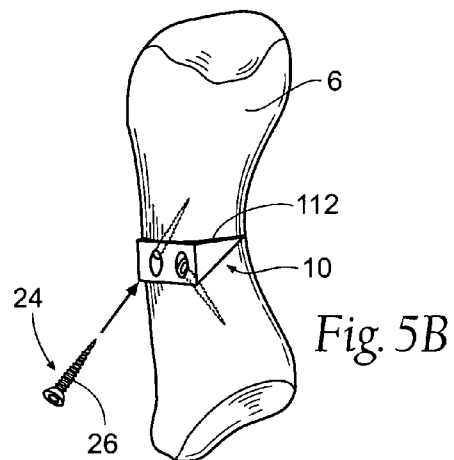
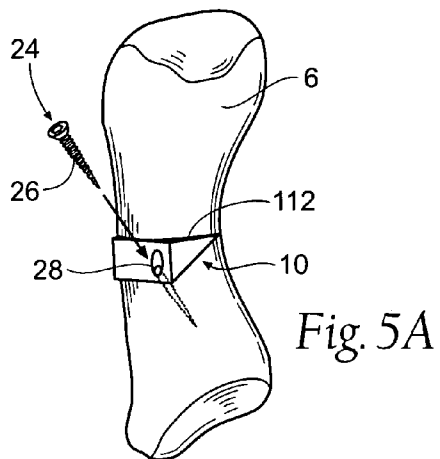

Fig. 4F



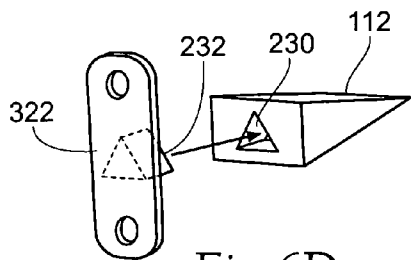

Fig. 6D

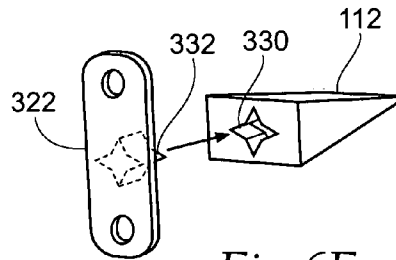

Fig. 6E

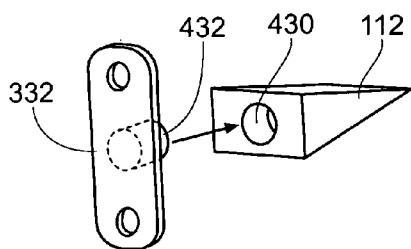

Fig. 6F

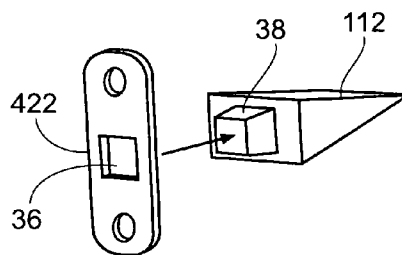

Fig. 6G

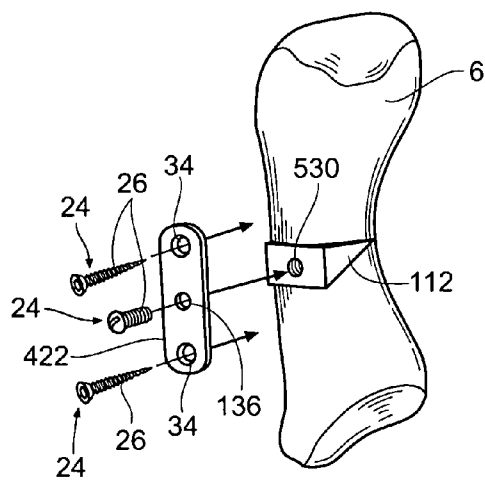

Fig. 7A

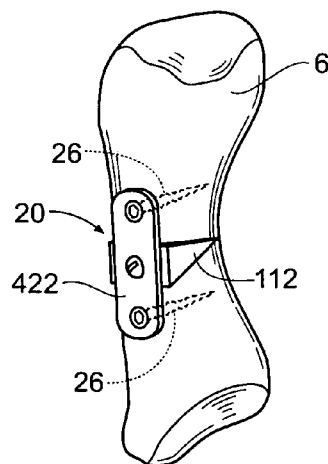

Fig. 7B

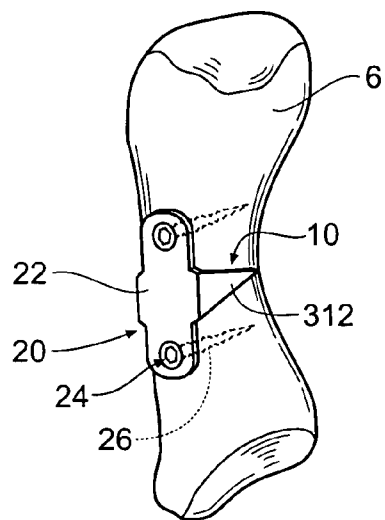

Fig. 8

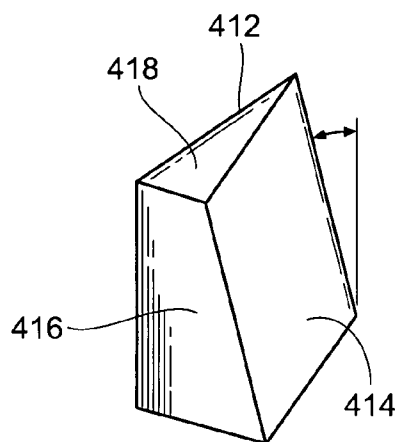

Fig. 9A

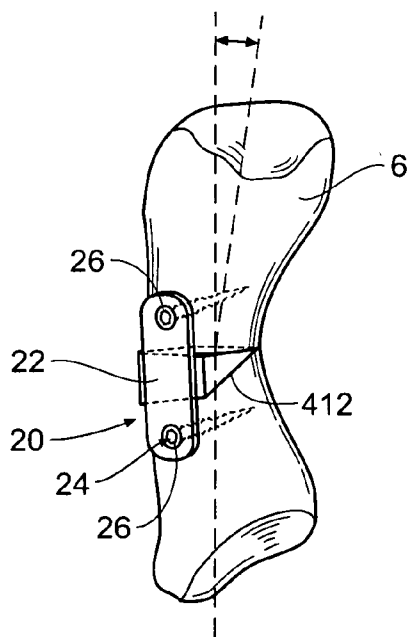

Fig. 9B

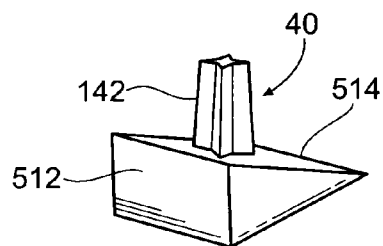
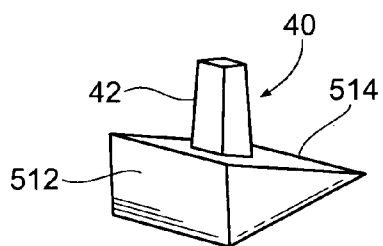
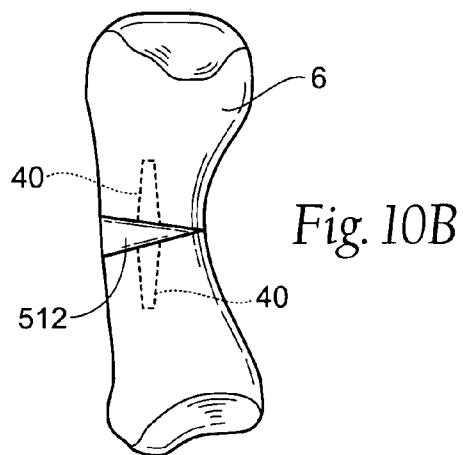
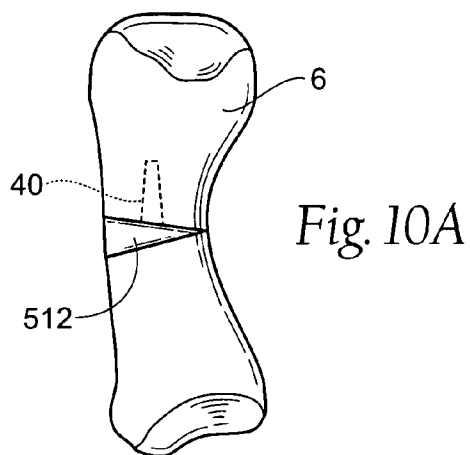

Fig. 10C

Fig. 10D

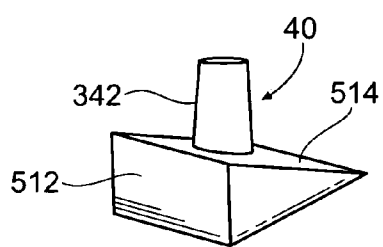
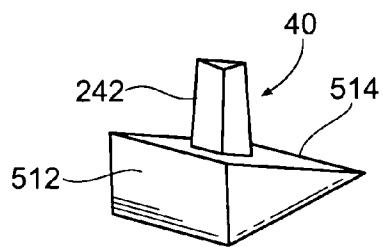

Fig. 10E

Fig. 10F

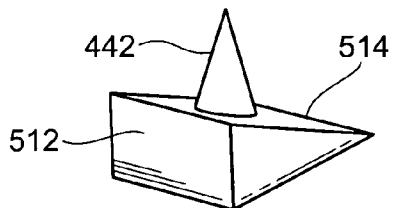

Fig. 10G

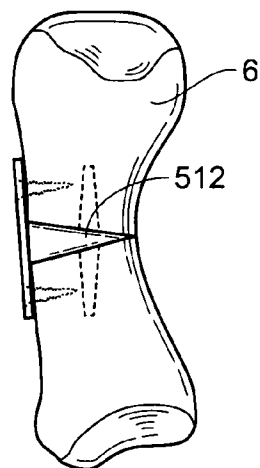

Fig. 10H

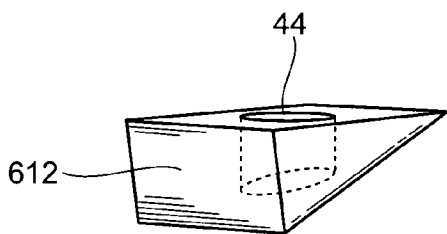

Fig. 11A

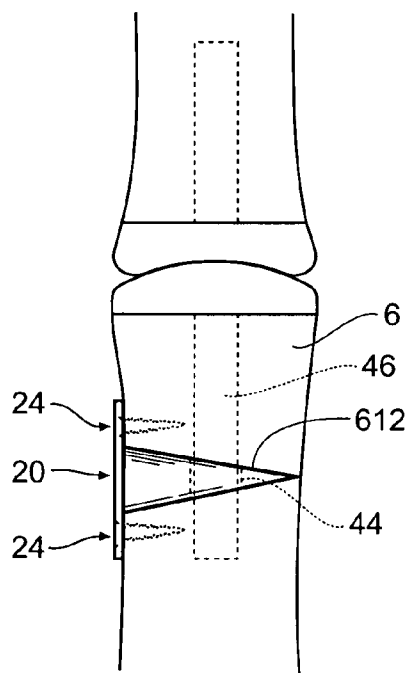

Fig. 11B



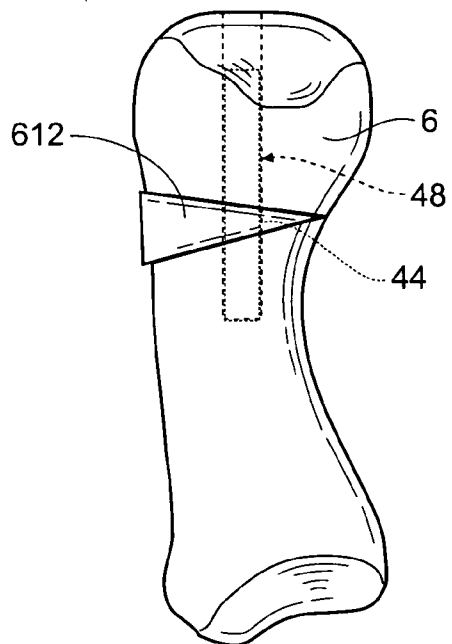

Fig. 11C

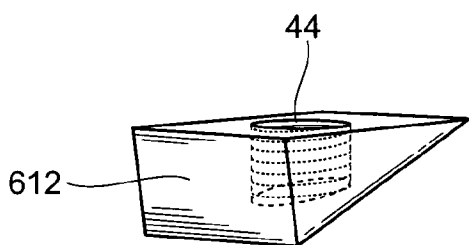

Fig. 11D

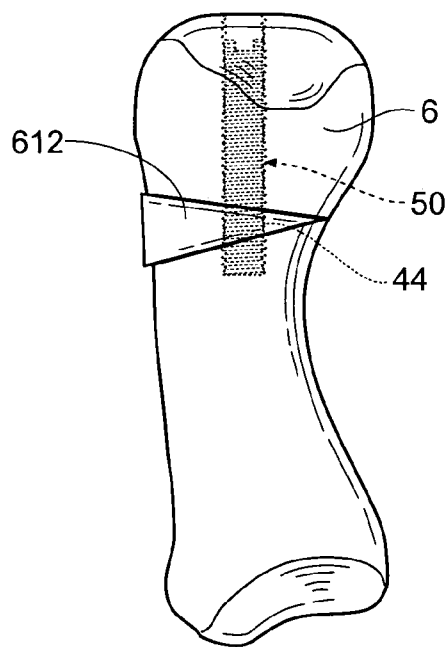

Fig. 11E

**DEVICES, SYSTEMS AND METHODS FOR RE-ALIGNMENT OF BONE**

**FIELD OF THE INVENTION**

[0001] The invention generally relates to devices, systems, and methods for realignment of bone, e.g. during bony osteotomy.

**BACKGROUND OF THE INVENTION**

[0002] There are many occasions in orthopedic surgery when a bone is angled improperly due to congenital deformity, trauma, failed surgeries, and uneven arthritic wear in joints. A surgical operation called an osteotomy is done to correct this misalignment. In an osteotomy the bone is cut and then realigned to correct the improper angle.

[0003] In an osteotomy procedure, the surgeon removes a wedge of bone near a damaged joint. The procedure shifts weight from an area where there is damaged cartilage to an area where there either more cartilage or healthier cartilage. In this manner, weight is spread more evenly across the joint cartilage.

[0004] Osteotomy is commonly performed on the knee or hip joint. Osteotomy may help correct knee deformities such as bowleg or knock-knee deformities. Osteotomy may also be used to correct damage due to arthritis. For example, osteotomy may be performed in patients too young for a total joint replacement.

[0005] It is desirable to provide a new device which both simplifies the re-angling operations and enables correction to be more precise.

**SUMMARY OF THE INVENTION**

[0006] The invention provides devices, systems, and methods for re-aligning or re-angling a bone.

[0007] One aspect of the invention provides a system comprising a body sized and shaped to re-align a bone region toward a desired anatomic position and at least one fixation member for securing the body to the bone region.

[0008] In one embodiment, the fixation member includes at least one fixation plate sized and configured for association with the body to secure the body to the bone region.

[0009] In one embodiment, the fixation member comprises at least one screw and/or at least one staple and/or at least one stem.

[0010] In one embodiment, the body includes at least one aperture formed through it sized and configured for engagement with a fixation member. In this arrangement, the aperture can include internal threads for receiving a screw.

[0011] In one embodiment, the body is generally wedge-shaped.

[0012] In one embodiment, the fixation member includes a fixation plate formed with a first surface geometry. In this arrangement, the body includes a second surface geometry that mates with the first surface geometry.

[0013] In one embodiment, the system further comprises a total joint replacement including a stem. In this arrangement, the body includes an aperture formed through it sized and configured for engaging the stem.

[0014] Another aspect of the invention provides an osteotomy device comprising a generally wedge-shaped body and at least one intramedullary post extending from the wedge-shaped body.

[0015] Another aspect of the invention provides a method comprising providing a body sized and shaped to re-align a bone region toward a desired anatomic position and at least one fixation member for securing the body to the bone region. The method includes selecting an bone region, forming a cavity in the bone region sized and configured to receive the body, and inserting the body in the bone region to re-align the bone region toward a desired anatomic position. The method includes fixing the body to the bone region with the fixation member.

[0016] Another aspect of the invention provides a method comprising providing a body sized and shaped to re-align a bone region toward a desired anatomic position and at least one fixation plate sized and configured for association with the body to secure the body to the bone region. The method includes selecting an bone region, forming a cavity in the bone region sized and configured to receive the body, and inserting the body in the bone region to re-align the bone region toward a desired anatomic position. The method includes fixing the body to the bone region with the fixation plate.

[0017] Another aspect of the invention provides a method comprising providing a body sized and shaped to re-align a bone region toward a desired anatomic position, the body including at least one aperture formed through it sized, and a fixation member sized and configured for engagement with aperture. The method includes selecting a bone region, forming a cavity in the bone region sized and configured to receive the body, and inserting the body in the bone region to re-align the bone region toward a desired anatomic position. The method includes fixing the body to the bone region by engaging the fixation member through the aperture.

[0018] Other objects, advantages, and embodiments of the invention are set forth in part in the description which follows, and in part, will be obvious from this description, or may be learned from the practice of the invention.

**BRIEF DESCRIPTION OF THE DRAWINGS**

[0019] FIG. 1 is a top view of a foot.

[0020] FIG. 2 is a front view of a leg.

[0021] FIG. 3 is a perspective view of a re-angling device according to the present invention.

[0022] FIG. 4A is a plan view of a bone with a wedge shaped gap cut therein.

[0023] FIG. 4B shows a re-angling device of the type shown in FIG. 3 being inserted into the bone of the type shown in FIG. 4A.

[0024] FIGS. 4C to 4F show a re-angling device of the type shown in FIG. 3 being secured to a bone of the type shown in FIG. 4A using alternative fixation plate and fixation member.

[0025] FIGS. 5A and 5B show an alternative embodiment of a re-angling device being inserted into a bone.

[0026] FIG. 6A is an exploded perspective view of an alternative re-angling device and fixation plate wherein the re-angling device is formed with a protrusion and the fixation plate is formed with a mating aperture.

[0027] FIG. 6B shows the alternative re-angling device and fixation plate of FIG. 6A secured in a bone of the type shown in FIG. 4A.

[0028] FIGS. 6C to 6F show additional alternative embodiments of the re-angling device and fixation plate of FIG. 6A.

[0029] FIG. 6G is an exploded perspective view of an alternative re-angling device and fixation plate wherein the re-

angling device is formed with an aperture and the fixation plate is formed with a mating protrusion.

[0030] FIG. 7A is an exploded perspective view of an alternative re-angling device and fixation plate being inserted into a bone of the same type shown in FIG. 4A.

[0031] FIG. 7B shows the alternative re-angling device and fixation plate of FIG. 7A secured in a bone of the same type as shown in FIG. 4A.

[0032] FIG. 8 shows an alternative re-angling device with an integrally formed fixation plate secured in a bone of the same type as shown in FIG. 4A.

[0033] FIG. 9A is a perspective view of an alternative embodiment of a re-angling device.

[0034] FIG. 9B shows the alternative re-angling device of FIG. 9A secured to a bone of the same type as shown in FIG. 4A by a fixation plate and fixation members.

[0035] FIGS. 10A and 10B show an alternative re-angling device inserted into a bone of the type shown in FIG. 4A.

[0036] FIGS. 10C to 10G show various alternative embodiments of the re-angling device of FIG. 10A.

[0037] FIG. 10H shows the re-angling device of FIG. 10B secured in the bone with a fixation plate and fixation members.

[0038] FIG. 11A is a perspective view of an alternative embodiment of the re-angling device of FIG. 3 with a hole therethrough for a total joint replacement stem.

[0039] FIG. 11B shows the re-angling device of FIG. 11A inserted into a bone.

[0040] FIG. 11C is a perspective view of an alternative embodiment of the re-angling device like that shown in FIG. 11A, inserted into a bone with the hole receiving a fixation pin.

[0041] FIG. 11D is a perspective view of an alternative embodiment of the re-angling device like that shown in FIG. 11A, the hole being internally threaded for receiving a screw.

[0042] FIG. 11E shows the re-angling device of FIG. 11E inserted into a bone and fixated with a screw through the hole.

#### DESCRIPTION OF THE PREFERRED EMBODIMENT

[0043] Although the disclosure hereof is detailed and exact to enable those skilled in the art to practice the invention, the physical embodiments herein disclosed merely exemplify the invention which may be embodied in other specific structures. While the preferred embodiment has been described, the details may be changed without departing from the invention, which is defined by the claims.

[0044] FIGS. 1 and 2 show the anatomy of the human foot and leg, respectively. While it is contemplated that osteotomy may be in any part of the human anatomy, osteotomy is commonly performed on the metatarsal and the femur.

##### I. Re-Angling Device with Separate Fixation Plate

[0045] FIG. 3 shows a device 10 for re-angling or realigning a bone region according to the present invention. This device 10 is sized and configured to be inserted into a gap formed in the bone region to accommodate placement of the device 10. The device 10 is sized and configured to re-angle or realign the bone region toward a desired anatomic position, e.g., during an osteotomy procedure.

[0046] In a first illustrated embodiment, the re-angling device 12 is generally wedge shaped, and is sized and configured to fit into a wedge-shaped gap cut into the bone region. The size and configuration of the re-angling device 12 can

vary, as long as it functionally serves to re-angle or realign the bone region in a desired manner.

[0047] In the embodiment shown in FIG. 3, the re-angling device 12 includes a generally rectangular base 16, a pair of wedge surfaces 14 which extend from laterally opposed edges of the base 16 and meet at a point opposite the base 16, and a pair of end surfaces 18 which extend from laterally opposed edges of the base 16 and engage one edge of each wedge surface 14.

[0048] In order to insert the device 12 into the bone 6, an appropriately sized wedge of bone is removed from the application site, creating a wedge-shaped gap 8, as shown in FIG. 4A. The application site is chosen by the physician based on the anatomy of the patient. The gap 8 is created using any appropriate surgical device, such as an appropriately sized and configured surgical saw. The device 12 is then inserted into the gap 8 in the bone 6 as shown in FIG. 4B. The device 12 may then be secured to the bone 6. The device 12 may be secured to the bone by any known method used in the art, for example, and not limited to bone cement, a temporary plate, and a permanent plate.

[0049] In one method of fixation, as shown in FIG. 4C, the device 12 is secured in the gap by placing a fixation plate 20 over the re-angling device 12. The fixation plate 20 is then attached to the bone 6 using a fixation member 24. In some circumstances, it may be desirable to drill pilot holes in either the fixation plate 20 or the bone 6 prior to inserting the fixation member 24. The fixation member 24 preferably extends through the fixation plate 20 and into the bone 6 to secure the re-angling device 12 to the bone 6.

[0050] In the embodiment shown in FIG. 4C, the fixation plate 20 takes the form of a single fixation plate 22 that extends across the entire length of the re-angling device 12.

[0051] It is also contemplated that the fixation plate 20 could take the form of multiple fixation plates 122, each of which extends across only a portion of the re-angling device, as shown in FIG. 4D.

[0052] In the representative embodiments shown in FIGS. 4C and 4D the fixation members 24 comprises screws 26, such as surgical screws. However, it should be understood that the fixation members may be chosen from a variety of fixation members known in the art. For example, the fixation member 24 could also be a bone staple 126, as shown in FIG. 4E or a barbed bone staple 226 as shown in FIG. 4F.

[0053] As shown in FIG. 4E, it may be desirable to provide the fixation plate 20 with at least one preformed aperture 34 through which a fixation member 24 may extend to secure the fixation plate 20 to the bone 6. The aperture 34 may be threaded or not threaded depending on the type of fixation member 24 to be used.

[0054] The size and shape of the device 10, fixation plate 20, and fixation members 24 are chosen by the physician based on each individual patient's anatomy and the type of bone in which the device is to be used.

[0055] The device 10, the fixation plate 20, and the fixation members 24 may be made of various materials commonly used in the prosthetic arts including, but not limited to, metals, ceramics, tantalum, polyethylene, biologic type polymers, hydroxyapatite, rubber, titanium, titanium alloys, tantalum, chrome cobalt, surgical steel, or any other total joint replacement metal and/or ceramic, bony in-growth surface, sintered glass, artificial bone, any porous metal coat, metal

meshes and trabeculations, metal screens, uncemented metal or ceramic surface, other bio-compatible materials, or any combination thereof.

**[0056]** It may be desirable to provide the device **10**, the fixation plate **20**, and the fixation members **24** with surfaces, or a portion of a surface, that allow for bony ingrowth. The surfaces of the device **10**, fixation plate **20**, and fixation members **24** could be covered with biological bone substitute or biological stimulators for example, but not limited to hydroxygretite, calcium phosphate, calcium sulfate, or one of the bone morphogenic stimulators. Alternatively, the surfaces of device **10**, the fixation plate **20**, and the fixation members **24** could be covered with surface texturing to induce bony in-growth. The surface texturing can comprise, e.g., through holes, and/or various surface patterns, and/or various surface textures, and/or pores, or combinations thereof. The device **10** can be coated or wrapped or surfaced treated to provide the surface texturing, or it can be formed from a material that itself inherently possesses a surface conducting to bony in-growth, such as a porous mesh, hydroxyapatite, or other porous surface.

**[0057]** It may further be desirably for the device **10** to be covered with various coatings such as antimicrobial, anti-thrombogenic, and osteoinductive agents, or a combination thereof.

#### II. Re-Angling Device Fixed with One or More Crossing Screws

**[0058]** It is further contemplated that the re-angling device **10** described above may be fixed by one or more fixation members inserted through the alternative re-angling device **112** as shown in FIGS. **5A** and **5B**. The re-angling device **112** may take generally the same form as described above. However, in such an embodiment the need for a fixation plate **20** is eliminated.

**[0059]** In order to insert the alternative re-angling device **112** into the bone **6**, an appropriately sized wedge of bone is removed from the application site, creating a wedge-shaped gap **8**, as shown in FIG. **4A**. The wedge-shaped gap **8** is formed using any appropriate surgical device, such as an appropriately sized and configured surgical saw. As discussed in reference to the embodiments above, the application site is chosen by the physician based on the anatomy of the patient. The size and particular configuration of the alternative re-angling device **112** is also selected by the physician based on the anatomy of the patient. The alternative re-angling device **112** may then be inserted into the gap **8** in the bone **6** and secured to the bone **8** by a fixation member **24** as shown in FIG. **5A**. In the illustrated embodiment the fixation member **24** comprises a threaded screw **26**. The fixation member **24** is secured using any appropriate surgical devices, such as an appropriately sized and configured surgical screwdriver. As shown in FIG. **5A**, the screw **26** is screwed through the re-angling device **112** and into the bone **6**. It is further contemplated that multiple fixation members **24** could be utilized to fasten a single re-angling device **112**, as shown in FIG. **5B**. It may be desirable, but not necessary, to have a pilot hole in the re-angling device **112** to aid in insertion of the at least one fixation member **24**. The re-angling device could be preformed with an aperture, such as a pilot hole **28**, as shown in FIG. **5A**. Alternatively, the pilot hole **28** could be drilled in the device **112** by the surgeon either before or after inserting the re-angling device **112** in the bone **6**. The re-angling device **112** and fixation members **24** may be formed of any appro-

priate prosthetic material as describe above, and if desirable may include surfaces adapted to promote bony-in-growth as also described above.

#### III. Re-Angling Device with Slot for Attachment to a Fixation Plate

**[0060]** In an additional representative embodiment, a re-angling device **10** may be removably coupled to a fixation plate **20**. As shown in FIG. **6A**, the re-angling device **112** and fixation plate **322** may take generally the same form as described above. However, the re-angling device **112** includes a first surface geometry **30** and the fixation plate **20** includes a second surface geometry **32** that nests or mates with the first surface geometry **30**. In the illustrated embodiment, the first surface geometry comprises a female aperture **30** and the second surface geometry comprises a mating male protrusion **32**. The protrusion **32** is sized and configured to be received in the aperture **30** formed in the re-angling device **112**. The mating male and female configurations may be reversed. That is, the first surface geometry on the device can comprise a male projection and the second surface geometry on the device comprises a mating female aperture.

**[0061]** In the first representative embodiment, the protrusion **32** and the aperture **30** each take a tapered rectangular shape. The protrusion **32** and aperture **30** may take any shape including, but not limited to square (see FIG. **6C**), morse taper, triangular (see FIG. **6D**), star-shaped (see FIG. **6E**), or round (see FIG. **6F**).

**[0062]** The re-angling device **112** and the fixation plate **322** may be coupled prior to inserting the re-angling device **112** into the bone **6**. Alternatively, the re-angling device **112** may first be inserted into the bone **6**, then the fixation plate **322** may be coupled to the re-angling device **112**.

**[0063]** The fixation plate **322** is then fixed to the bone **6** by at least one fixation member **24**, as shown in FIG. **6B** and described in further detail above. In the illustrated embodiment, the fixation member **24** takes the form of a screw **26**, however it should be understood that the fixation member **24** may take any form.

**[0064]** Alternatively the re-angling device **212** may be formed with a protrusion **38** and the fixation plate **422** may be formed with a mating aperture **36**, as shown in FIG. **6H**. The illustrated embodiment includes a rectangular tapered protrusion **38** and a generally rectangular aperture **36**, however as described above, the aperture **36** and protrusion **38** may take any mating shape.

**[0065]** In order to insert the device **112** into the bone, an appropriately sized wedge of bone is removed from the application site, creating a wedge-shaped gap **8**, as shown in FIG. **4A**. The application site is chosen by the physician based on the anatomy of the patient.

**[0066]** The re-angling device **112,212**, fixation plate **322,422** and fixation members **24** may be formed of any appropriate prosthetic material as describe above, and if desirable may include surfaces adapted to promote bony-in-growth as also described above.

#### IV. Re-Angling Device with Hole for Screw Attachment to a Fixation Plate

**[0067]** In an additional representative embodiment both the re-angling device **10** and the fixation plate **20** may be preformed with an aperture. As shown in FIG. **7A**, an aperture **530** is formed in the re-angling device **112** and an aperture **136** is formed in the fixation plate **422**. In this manner, the

fixation plate 422 may be fixed to the re-angling device 112 via a fixation member 24 such as a screw 26, as shown in FIG. 7B.

[0068] It is contemplated that the aperture 136 in the fixation plate 422 and the aperture 530 in the re-angling device 112 could be threaded as shown in FIG. 7A, or unthreaded. It is also contemplated that the aperture 136 in the fixation plate 422 could be threaded while the aperture 530 in the re-angling device 112 is not threaded, or vice versa.

[0069] It may be desirable, although not necessary, to provide the fixation plate 422 with at least one aperture 34 through which the fixation members 24 may extend as shown in FIG. 7A. It may be desirable, but not necessary, to provide the at least one aperture 34 with internal threads as shown in FIG. 7A.

[0070] The re-angling device 112 is generally wedge-shaped, as described above. The size and specific configuration of the re-angling device 112, fixation plate 422, and fixation members 24 are chosen by the physician based on each individual patient's anatomy and the type of bone in which the device 112 is to be used. The re-angling device 112 and the fixation plate 422 may be attached prior to inserting the re-angling device 112 into the bone 6, or after the re-angling device 112 has been inserted into the bone 6.

[0071] As described above with respect to the previous embodiments, in order to insert the re-angling device 112 into the bone 6, an appropriately sized wedge of bone is removed from the application site, creating a wedge-shaped gap 8, as shown in FIG. 4A. The wedge-shaped gap 8 is formed using any appropriate surgical device, such as an appropriately sized and configured surgical saw. As discussed in reference to the embodiments above, the application site is chosen by the physician based on the anatomy of the patient. The size and particular configuration of the re-angling device is also selected by the physician based on the anatomy of the patient. The re-angling device 112 is then inserted into the gap 8 in the bone 6 and secured to the bone 6 by a fixation member 24 as shown in FIG. 7B. In the illustrated embodiment the fixation member 24 comprises a threaded screw 26, however it should be understood that any appropriate fastener may be utilized. The fixation member 24 is secured using any appropriate surgical devices, such as an appropriately sized and configured surgical screwdriver. As shown in FIG. 7B, the screw 26 is screwed through the fixation member 422 and into the bone 6.

[0072] The re-angling device 112, fixation plate 422 and fixation members 24 may be formed of any appropriate prosthetic material as describe above, and if desirable may include surfaces adapted to promote bony-in-growth as also described above.

#### V. Re-Angling Device with Integral Fixation Plate

[0073] In an additional representative embodiment, the re-angling device 10 and the fixation plate 20 are integrally formed as a single device 312, as shown in FIG. 8. The alternative re-angling device 312 may take generally the same wedge-shaped configuration as described above.

[0074] To insert the device 312 into the bone 6, an appropriately sized wedge of bone 6 is removed from the application site, creating a wedge-shaped gap 8, as shown above in FIG. 4A. The application site is chosen by the physician based on the anatomy of the patient. The device 312 is then inserted into the gap 8 in the bone as shown in FIG. 8 and secured to the bone 6. In one embodiment, the re-angling device 312 may be fixed to the bone through at least one fixation member 20. In

the illustrated embodiment, the fixation member 20 takes the form of a screw 26. However, the fixation member 20 may comprise any suitable fixation member, including, by means of example a surgical screw or a surgical staple. As described above, and shown in FIG. 7A, it may be desirable, although not necessary to include apertures 34 in the fixation plate portion 22 of the device 312 through which the fixation members 24 may extend. It is further contemplated that in some situations it may be desirable, although not necessary, to provide the apertures 34 in the fixation plate portion 22 with pre-formed threads, as described in detail above.

[0075] The size and the particular configuration of the re-angling device 312 are preferably chosen by the physical based on the anatomy of the patient being treated.

[0076] The re-angling device 312 and fixation members 24 may be formed of any appropriate prosthetic material as describe above, and if desirable may include surfaces adapted to promote bony-in-growth as also described above.

#### VI. Wedge with Angle in Two Planes

[0077] In an additional representative embodiment shown in FIGS. 9A and 9B, the re-angling device 412 may be formed such that the bone 6 may be angled in two planes. The configuration of the re-angling device is similar to that shown in FIG. 3 and described above, however the base 416 is generally trapezoidal, rather than rectangular.

[0078] To insert the device 412 into the bone 6, an appropriately sized wedge of bone 6 is removed from the application site, creating a wedge-shaped gap 8, as shown above in FIG. 4A. The application site is chosen by the physician based on the anatomy of the patient. The device 412 is then inserted into the gap 8 in the bone as shown in FIG. 9B and secured to the bone 6. In one embodiment, the re-angling device 412 may be fixed to the bone through at least one fixation member 20. In the illustrated embodiment, the fixation member 20 takes the form of a screw 26. However, the fixation member 20 may comprise any suitable fixation member, including, by means of example a surgical screw or a surgical staple. As described above, and shown in FIG. 7A, it may be desirable, although not necessary to include apertures 34 in the fixation plate portion 22 of the device 312 through which the fixation members 24 may extend. It is further contemplated that in some situations it may be desirable, although not necessary, to provide the apertures 34 in the fixation plate portion 22 with pre-formed threads, as described in detail above.

[0079] The size and the particular configuration of the re-angling device 412 are preferably chosen by the physical based on the anatomy of the patient being treated.

[0080] The re-angling device and fixation members may be formed of any appropriate prosthetic material as describe above, and if desirable may include surfaces adapted to promote bony-in-growth as also described above.

#### VII. Re-Angling Device with Intramedullary Post

[0081] In an additional representative embodiment, the re-angling device 512 may include at least one intramedullary post 40, as shown in FIG. 10A. The intramedullary post 40 may extend into the bone 6 to further secure the re-angling device 512 within the bone 6.

[0082] To insert the device 512 into the bone 6, an appropriately sized wedge of bone 6 is removed from the application site, creating a wedge-shaped gap 8, as shown above in FIG. 4A. At least one aperture may be formed in the bone 6, the aperture being adapted to accept the at least one intramedullary post 40. The application site is chosen by the physician based on the anatomy of the patient. The device 512 is then

inserted into the gap **8** in the bone as shown in FIG. **8** and secured to the bone **6**. The size and the particular configuration of the re-angling device **512** are preferably chosen by the physical based on the anatomy of the patient being treated.

[0083] It is further contemplated that the re-angling device **512** could be formed with a pair of posts **40**, as shown in FIG. **10B**.

[0084] It is further contemplated that the post **40** on the re-angling device **512** could take any shape. For example, the post could be square (see FIG. **10C**), star-shaped (see FIG. **10D**), triangular (see FIG. **10E**), rounded (see FIG. **10F**) or pointed (see FIG. **10G**).

[0085] The re-angling device **512** may be formed of any appropriate prosthetic material as describe above, and if desirable may include surfaces adapted to promote bony-in-growth as also described above.

#### VIII. Re-Angling Device for Use with Stem of Total Joint Replacement or Internal Fixation

[0086] It is also contemplated that any of the re-angling devices described above may be formed with a hole **44** there-through as shown in FIG. **11A**.

[0087] The hole **44** may be sized and configured for the particular application. For example, the hole **44** may be sized and configured such that when the re-angling device **612** is inserted into the bone **6**, the stem **46** of a total joint replacement may be inserted through the hole **44**, as shown in FIG. **11B**. Alternatively, the hole **44** may be sized and configured for receiving a pin **48**, as shown in FIG. **11C**. Alternatively, the hole **44** may be internally threaded, as shown in FIG. **11D**, and be sized and configured for receiving a screw **50**, as shown in FIGS. **11D** and **11E**. In any embodiment, the basic configuration of the re-angling device **612** is the same as described above. The particular size and configuration of the device **612** is determined by the physician based on the bone being treated and the anatomy of the patient.

[0088] In order to insert the device **612** into the bone, an application site is chosen by the physician based on the anatomy of the patient. An appropriately sized wedge of bone is removed from the application site, creating a wedge-shaped gap **8**, as shown in FIG. **4A**. The device **612** may then be inserted into the gap in the bone as shown in FIG. **11B**. The device **612** may then be secured to the bone **6** by any known method used in the art. For example, the device **612** may be secured in the gap **8** by placing a fixation plate **20** over the re-angling device **612**, as FIG. **11B** shows. The fixation plate **20** can be attached to the bone **6** using at least one fixation member **24**. The fixation member **24** preferably extends through the fixation plate **20** and into the bone **6** to secure the re-angling device **612** to the bone **6**. In the illustrative embodiment, the fixation member **24** comprises at least one screw, however any appropriate fixation member **24** may be utilized without departing from the invention. In FIG. **11B**, the re-angling device **612** is oriented so that the hole **44** receives the stem **46** of a total joint replacement. In other embodiments, the device **612** may be oriented so that the hole receives a pin **48** (FIG. **11C**) or a screw **50** (FIG. **11E**), which can be installed using standard surgical procedures known in the art. The pin **48** or screw **50** secures the re-angling device **612** to the bone through the hole **44**. In these arrangements, a fixation plate **20** (as shown in FIG. **11B**) need not be provided, but optionally, it can be, if additional fixation is desired.

[0089] It may be desirable to provide the fixation plate **20** or plates with at least one preformed aperture **34** through which a fixation member **24** may extend to secure the fixation plate

**20** to the bone **6**, as shown in FIGS. **6A** and **6B**. The aperture **34** may be threaded or not threaded.

[0090] The re-angling device **612** and fixation members **20**, **24**, **46**, **48**, and **50** may be formed of any appropriate prosthetic material as describe above, and if desirable may include surfaces adapted to promote bony-in-growth as also described above.

[0091] The foregoing is considered as illustrative only of the principles of the invention. Furthermore, since numerous modifications and changes will readily occur to those skilled in the art, it is not desired to limit the invention to the exact construction and operation shown and described. While the preferred embodiment has been described, the details may be changed without departing from the invention, which is defined by the claims.

I claim:

1. A system comprising a body sized and shaped to re-align a bone region toward a desired anatomic position; and at least one fixation member for securing the body to the bone region.
2. A system according to claim 1 wherein the fixation member includes at least one fixation plate sized and configured for association with the body to secure the body to the bone region.
3. A system according to claim 1 wherein the fixation member includes at least two fixation plates each sized and configured for association with the body to secure the body to the bone region.
4. A system according to claim 1 wherein the fixation member comprises at least one screw.
5. A system according to claim 1 wherein the fixation member comprises at least one staple.
6. A system according to claim 5 wherein the staple comprises at least one barbed staple.
7. A system according to claim 1 wherein the body includes at least one aperture formed through it sized and configured for engagement with a fixation member.
8. A system according to claim 7 wherein the aperture includes internal threads.
9. A system according to claim 1 wherein the body is generally wedge-shaped.
10. A system according to claim 1 wherein said the fixation member includes a fixation plate formed with a first surface geometry, and wherein the body includes a second surface geometry that mates with the first surface geometry.
11. A system according to claim 10 wherein the first surface geometry comprises at least one projection and the second surface geometry comprises at least one mating aperture, or vice versa.
12. A system according to claim 1 further comprising a total joint replacement including a stem; and wherein the body includes an aperture formed through it sized and configured for engaging the stem.
13. A system according to claim 1 wherein at least one of the body and the fixation member comprises a prosthetic material.
14. A system according to claim 1 wherein at least one of the body and the fixation member comprises a biological material.

**15.** A system according to claim 1 wherein at least one of the body and the fixation member includes a region permitting bony in-growth and/or through-growth.

**16.** A system of claim 1 wherein said fixation member and the body are integrally formed.

**17.** An osteotomy device comprising a generally wedge-shaped body; and at least one intramedullary post extending from the wedge-shaped body.

**18.** A method comprising providing a body sized and shaped to re-align a bone region toward a desired anatomic position and at least one fixation member for securing the body to the bone region, selecting an bone region; forming a cavity in the bone region sized and configured to receive the body; inserting the body in the bone region to re-aligned the bone region toward a desired anatomic position; and fixing the body to the bone region with the fixation member.

**19.** A method comprising providing a body sized and shaped to re-align a bone region toward a desired anatomic position and at least one fixation plate sized and configured for association with the body to secure the body to the bone region; selecting an bone region; forming a cavity in the bone region sized and configured to receive the body; inserting the body in the bone region to re-aligned the bone region toward a desired anatomic position; and fixing the body to the bone region with the fixation plate.

**20.** A method comprising providing a body sized and shaped to re-align a bone region toward a desired anatomic position, the body including at least one aperture formed through it sized, and a fixation member sized and configured for engagement with aperture; selecting an bone region; forming a cavity in the bone region sized and configured to receive the body; inserting the body in the bone region to re-aligned the bone region toward a desired anatomic position; and fixing the body to the bone region by engaging the fixation member through the aperture.

\* \* \* \* \*