



(51) International Patent Classification:

A61B 5/00 (2006.01) *A61M 21/02* (2006.01)
A61B 5/02 (2006.01) *G02B 27/01* (2006.01)
A61M 21/00 (2006.01) *G06F 3/01* (2006.01)

(21) International Application Number:

PCT/US2018/020547

(22) International Filing Date:

01 March 2018 (01.03.2018)

(25) Filing Language:

English

(26) Publication Language:

English

(30) Priority Data:

62/466,281 02 March 2017 (02.03.2017) US

(71) Applicant: SANA HEALTH, INC. [US/US]; 1904 5th Ave., San Rafael, CA 94901 (US).

(72) Inventor: HANBURY, Richard; 1904 5th Ave., San Rafael, CA 94901 (US).

(74) Agent: VOSEN, Steven, R.; 1569 Solano Ave., #206, Berkeley, CA 94707 (US).

(81) Designated States (unless otherwise indicated, for every kind of national protection available): AE, AG, AL, AM, AO, AT, AU, AZ, BA, BB, BG, BH, BN, BR, BW, BY, BZ, CA, CH, CL, CN, CO, CR, CU, CZ, DE, DJ, DK, DM, DO, DZ, EC, EE, EG, ES, FI, GB, GD, GE, GH, GM, GT, HN, HR, HU, ID, IL, IN, IR, IS, JO, JP, KE, KG, KH, KN, KP, KR, KW, KZ, LA, LC, LK, LR, LS, LU, LY, MA, MD, ME, MG, MK, MN, MW, MX, MY, MZ, NA, NG, NI, NO, NZ, OM, PA, PE, PG, PH, PL, PT, QA, RO, RS, RU, RW, SA, SC, SD, SE, SG, SK, SL, SM, ST, SV, SY, TH, TJ, TM, TN, TR, TT, TZ, UA, UG, US, UZ, VC, VN, ZA, ZM, ZW.

(84) Designated States (unless otherwise indicated, for every kind of regional protection available): ARIPO (BW, GH, GM, KE, LR, LS, MW, MZ, NA, RW, SD, SL, ST, SZ, TZ, UG, ZM, ZW), Eurasian (AM, AZ, BY, KG, KZ, RU, TJ, TM), European (AL, AT, BE, BG, CH, CY, CZ, DE, DK, EE, ES, FI, FR, GB, GR, HR, HU, IE, IS, IT, LT, LU, LV, MC, MK, MT, NL, NO, PL, PT, RO, RS, SE, SI, SK, SM, TR), OAPI (BF, BJ, CF, CG, CI, CM, GA, GN, GQ, GW, KM, ML, MR, NE, SN, TD, TG).

Published:

— with international search report (Art. 21(3))

(54) Title: METHODS AND SYSTEMS FOR MODULATING STIMULI TO THE BRAIN WITH BIOSENSORS

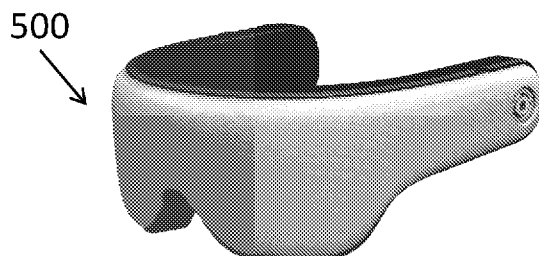

FIG. 5

(57) Abstract: Visual and auditory stimuli are provided to a patient to treat various neurological disorders or conditions and/or to provide improved mental or physical performance. The visual and auditory stimuli are provided by a wearable headset or sleep mask that may be comfortably worn by a user, such as in bed to induce sleep. The wearable headset or sleep mask includes, or works in cooperation with, sensors that determine the state of the user and modify the operation of the headset for treating various disorders or contentions.



METHODS AND SYSTEMS FOR MODULATING STIMULI TO THE BRAIN WITH BIOSENSORS

TECHNICAL FIELD

[0001] The present disclosure relates to medical and consumer devices and methods. In particular, the present disclosure relates to modulating, with biosensor feedback, neurological stimuli to a subject to treat various neurological disorders or conditions and/or to provide relaxation and/or performance enhancement.

BACKGROUND ART

[0002] Sensory stimulation has been used to treat various disorders. For example, binaural beats have applied to induce various mental states to encourage sleep, relaxation, meditation, creativity, and other desirable mental states. Combinations of auditory and visual stimuli have been applied to encourage such mental states as well. The application of such therapy, however, has been less than ideal in many circumstances. Equipment to provide the stimulus can be bulky, expensive, generally inaccessible, and below the critical efficacy threshold for widespread use, typically only helping subsets of the population. Users may find the use of such equipment difficult in many circumstances, such as when trying to sleep in a bedroom or an airplane cabin.

[0003] To treat various neurological disorders and conditions, pharmaceuticals and/or supplements are often used instead of sensory stimulation. The use of pharmaceuticals, however, can be less than ideal in many circumstances. Often, pharmaceuticals are expensive, rely on patient-compliance, and may require a prescription from a medical professional. Pharmaceuticals may be effective in only a small, less than ideal portion of the general population. To treat insomnia, for example, pharmaceuticals and supplements such as melatonin and Zolpidem (e.g., AMBIENTTM) have questionable efficacy. Pharmaceuticals often lead to undesirable side effects. For example, some pharmaceutical for treating insomnia can lead to deprivation in certain ranges of deep sleep and increases in mortality rates.

[0004] For at least these reasons, improved methods and systems to treat neurological disorders and other conditions that overcome at least some of the aforementioned challenges are desired.

DISCLOSURE OF INVENTION

[0005] The present disclosure relates to medical devices and methods which may be used, for example, to provide stimulus to a subject to treat various neurological disorders or conditions, where the stimulus provided may include one or more of an auditory, a visual, or a tactile

stimulus. In certain embodiments, sensory stimulation is tailored to an individual's response to that stimulus, resulting in greatly enhanced benefits to the user. Certain embodiments include biosensors that measure heart rate, heart rate variability, temperature, brain activity (detected, for example and without limitation by an electroencephalogram (EEG)), eye movement or levels of relaxation (detected, for example and without limitation by an electromyography (EMG)), and/or acceleration of the user to determine the effectiveness of the device and method and then modify the stimulus to achieve desired results. Thus, for example, if a user is using the device or method to relax and the biosensor indicates that a user has reached a relax state, then the device or method is programmed to reduce the intensity and/or time of the stimulus, or to favor certain types of stimulus.

[0006] In certain embodiments, the sensory stimulation is tailored to the user based on the biological response of the individual in real time. Thus, for example and without limitation, measurements of heart rate, brain activity, temperature, and/or indications of stress levels or sleep may be obtained and used to modify the time, intensity, and/or pattern of stimuli provided to a person.

[0007] Examples of neurological disorders which may be treated with devices and methods may include, but are not limited to, insomnia, post-traumatic stress disorder (PTSD), brain injuries including, but not limited to traumatic brain injury (TBI), mild traumatic brain injury (mTBI), or injury from oxygen deprivation of the brain from strokes, depression, anxiety, mood disorders, personality disorders, eating disorders, psychotic disorders, and balance disorders. Alternatively, or in combination, the stimulus provided by the medical devices and methods described herein may provide cognitive benefits and/or enhancement, including, but not limited to, improving neuroplasticity, motor skills, coordination, reaction times, alertness, energy, working memory, mood, relaxation, improved sleep (latency and or quality) and feelings of wellbeing.

[0008] In certain embodiments, stimuli may be provided to the wearer of a headset or sleep mask that may be comfortably worn by a user, such as in bed to induce sleep. The wearable headset or sleep mask may be operated by a personal computing device of the user, such as smartphone, having downloaded and active thereon a control application or "app" for the therapy. The wearable headset or sleep mask may also concurrently provide tactile stimuli, and the tactile stimuli may be provided from bone conduction transducer that may concurrently provide the auditory stimuli. Various patterns of the stimuli to induce different user responses are also disclosed. Certain embodiments thus alter, in real time, stimulus to the user based on the

response of the individual using one or more sensors mounted within the headset sensing biological signals, including but not limited to heart rate, heart rate variability, temperature, motion, galvanic skin response, eye movement or state of relaxation using EMG and EEG. The sensor measures the response of the individual to the stimulus and alters the patterns accordingly.

[0009] The primary ways by which the stimulus can be optimally altered using the sensor data includes, but are not limited to, changing the volume of the auditory stimulation and brightness of the visual stimulation in response to the change in level of relaxation or arousal of the subject, and/or shortening or lengthening the duration of each of the sections in the patterns disclosed.

[0010] In certain embodiments, a device is provided that produces an output that may be perceived by a user of the device as a visual, auditory or tactile stimulus at one or more frequencies, or in one or more frequency ranges. This is augmented to include a sensor providing changes to the stimulus. In certain embodiments, the stimuli may be turned on and off at frequencies that are believed to induce one or more frequencies of electrical activity in the brain, which are generally accepted as being delta waves (1.0 to 3.0 Hz), theta waves (3.0 to 7.0 Hz), alpha waves (7.0 to 12 Hz), beta waves (12 to 38 Hz), and gamma waves (38 to 42 Hz).

[0011] Thus, for example, one embodiment device produces an output that may be perceived by a user of the device as a stimulus at sequential frequencies, such as sequences of alpha waves, theta waves, and delta waves. In certain embodiments, the stimuli are a coordinated auditory and visual stimulation, providing right and left eyes and ears to pulsed light and pulsed auditory in each of the ranges listed above. As one example, the coordinated stimulation may be: 1) both eyes and both ears being stimulated at the same time; 2) the left eye and ear being stimulated at the same time, followed by the right eye and ear being stimulated at the same time; 3) both eyes being stimulated at the same time, followed by both ears being stimulated at the same time; or 4) the right eye and left ear being stimulated at the same time, followed by the left eye and right eye being stimulated at the same time. In each case, the stimulation may include, for example, sequentially stimulating in the alpha wave range, followed by the theta wave range, followed by the delta wave range. The stimulation can last for a period of one minute up to an hour.

[0012] It is one aspect to provide a method of providing stimulation to a user for a treatment time. The method includes: providing a headset to be worn by the user, where the headset includes four stimuli sources including a left light source activated to provide visual stimuli to the left eye of the user, a right light source activated to provide visual stimuli to the right eye of the user, a left vibration source activated to provide auditory stimuli to the left side of a head of

the user, and a right vibration source activated to provide auditory stimuli to the right side of the head of the user; obtaining a measurement of the user using a sensor; determining a state of the user from the obtained measurement; activating each of the stimuli sources between a high stimuli and a low stimuli at a stimulation frequency for a period of time including, where at least part of the activating includes activating at least two of the four stimuli sources out of phase with the activating of at least two other of the four stimuli sources; and modifying the activating according to the determined state of the user. In one embodiment, the activating further includes synchronously activating the four stimuli sources for a period of time.

[0013] In another embodiment, the activating includes one or more of: synchronously activating the left light source and the left vibration source out of phase with the right light source and the right vibration source for a period of time, synchronously activating the left light source and the right light source out of phase with the left vibration source and the right vibration source for a period of time, or synchronously activating the left light source and the right vibration source out of phase with the left vibration source and the right light source for a period of time.

[0014] In yet another embodiment, the activating includes alternating between: synchronously activating the four stimuli sources for a period of time, synchronously activating the left light source and the left vibration source out of phase with the right light source and the right vibration source for a period of time, synchronously activating the left light source and the right light source out of phase with the left vibration source and the right vibration source for a period of time, and synchronously activating the left light source and the right vibration source out of phase with the left vibration source and the right light source for a period of time.

[0015] In one embodiment, modifying includes modifying the stimulation frequency of the four stimuli sources. In another embodiment, the modifying includes modifying the temporal length of the activating of the four stimuli sources. In yet another embodiment, the modifying includes modifying a high stimuli level of at least one stimuli source of the four stimuli sources. In one embodiment, the modifying includes modifying the temporal length of the activating of the four stimuli sources.

[0016] In one embodiment, the sensor is a heart rate sensor, a heart rate variability (HRV) sensor, a temperature sensor, a motion sensor, a galvanic skin response sensor, an accelerometer, an EEG or an EMG. In one embodiment, the determined state of the user is a state of sleep or the level or change in level of relaxation or arousal.

[0017] In another embodiment, the modifying includes modifying a high stimuli level of the left vibration source and the right vibration source. In one embodiment, the modifying includes modifying a high stimuli level of the left light source and the right light source. In yet another embodiment, the activating according to the determined state of the user includes modifying the temporal length of the activating of the four stimuli sources.

[0018] In one embodiment, the activating includes activating each of the stimuli sources at a first stimulation frequency for a first period of time and activating each of the stimuli sources at a second stimulation frequency for a second period of time, where the first stimulation frequency is in a first frequency range of 1.0 and 3.0 Hz, 3.0 to 7.0 Hz, 7.0 to 12 Hz, 12 to 38 Hz or 38 to 42 Hz, and where the second stimulation frequency is in a second frequency range of 1.0 and 3.0 Hz, 3.0 to 7.0 Hz, 7.0 to 12 Hz, 12 to 38 Hz or 38 to 42 Hz, and where the first stimulation frequency is in a different frequency range than the second stimulation frequency range.

[0019] In one embodiment, the determined state of the user is a state of sleep determined to be REM sleep, the where the modifying the activating according to the determined state of the user includes reducing the high stimuli level at least one of the four stimuli sources. In another embodiment, the sensor is a temperature sensor, an EMG sensor, a heart rate sensor, an HRV sensor, and EEG sensor, or an accelerometer. In yet another embodiment, the sensor is two or more sensors including a first sensor including one of an HRV sensor or a heart rate sensor and one or more sensors including a temperature sensor, an EMG sensor, an EEG sensor, or an accelerometer. In one embodiment, the modifying the activating according to the determined state of the user includes reducing the stimuli level of each of four stimuli sources until the stimuli sources are turned off.

[0020] In one embodiment, the sensor is a heart rate sensor or a heart rate variability (HRV) sensor, where the determined state of the user is a state of relaxation or sleep state indicated by the HRV. In another embodiment, the determined state of the user is a state of relaxation or sleep state indicated by an increase in HRV, and where the modifying the activating according to the determined state of the user includes reducing the stimuli level of each of four stimuli sources until the stimuli sources are turned off and/or shortening the treatment time. In yet another embodiment, the determined state of the user is a less relaxed state or stressed state indicated by a decrease in HRV, and where the modifying the activating according to the determined state of the user includes increasing the stimuli level of each of four stimuli sources and/or increasing the treatment time.

[0021] In one embodiment, the determined state of the user is a hemispheric imbalance of brainwaves, where the sensor is an EEG sensor, where the state is the hemispheric imbalance of brainwaves includes a more active hemisphere of the brain, and where the modifying the activating according to the determined state of the user includes increasing the high stimuli level stimuli sources to the less active hemisphere of the brain.

[0022] One embodiment is a device to provide stimulation to a user for a treatment time. The device includes: a headset to be worn by the user, where the headset includes four stimuli sources including a left light source activated to provide visual stimuli to the left eye of the user, a right light source activated to provide visual stimuli to the right eye of the user, a left vibration source activated to provide auditory stimuli to the left side of a head of the user, and a right vibration source activated to provide auditory stimuli to the right side of the head of the user, a sensor in to obtain a measurement of the user; and a processor. The processor is programmed to accept the measurement and determine a state of the user from the measurement, determine a state of the user from the obtained measurement, activate each of the stimuli sources between a high stimuli and a low stimuli at a stimulation frequency for a period of time including, where at least part of the activating includes activating at least two of the four stimuli sources out of phase with the activating of at least two other of the four stimuli sources, and modify the activation of each of the stimuli sources according to the state of the user.

[0023] In one embodiment, the sensor includes one or more of a heart rate sensor, a heart rate variability (HRV) sensor, a temperature sensor, a motion sensor, a galvanic skin response sensor, an accelerometer, an EEG or an EMG. In another embodiment, the processor is programmed to further activate the four stimuli sources synchronously for a period of time. In yet another embodiment, the processor is programmed to alternate between synchronously activating the four stimuli sources for a period of time, synchronously activating the left light source and the left vibration source out of phase with the right light source and the right vibration source for a period of time, synchronously activating the left light source and the right light source out of phase with the left vibration source and the right vibration source for a period of time, and synchronously activating the left light source and the right vibration source out of phase with the left vibration source and the right light source for a period of time.

[0024] In one embodiment, the state of the user is a state of sleep or the level or change in level of relaxation or arousal determined from a temperature sensor, a heart rate or HRV sensor. In yet another embodiment, the processor is programmed to modify the activation of each of the stimuli sources according to the state of the user includes one or more of changing the high

stimuli level at least one of the four stimuli sources, the stimulation frequency, or the treatment time.

[0025] In one embodiment, the state of the user is a state of hemispheric imbalance of brainwaves, where the sensor is an EEG sensor, where processor is programmed to increase the high stimuli level stimuli sources to the less active hemisphere of the brain.

[0026] These features together with the various ancillary provisions and features which will become apparent to those skilled in the art from the following detailed description, are attained by the methods and system for providing stimulation to a user of the present invention, embodiments thereof being shown with reference to the accompanying drawings, by way of example only, wherein:

BRIEF DESCRIPTION OF DRAWINGS

[0027] FIGS. 1A and 1B show schematic diagrams of therapeutic systems to provide therapeutic auditory, visual, and/or tactile stimulus to the user;

[0028] FIGS. 2A and 2B show schematic diagrams of the controller for the therapeutic systems of FIGS. 1A and 1B;

[0029] FIG. 3A shows a first embodiment therapeutic wearable headset or sleep mask;

[0030] FIG. 3B shows a user wearing the therapeutic wearable headset and sleep mask of FIG. 3A;

[0031] FIG. 4 shows a flow chart of a therapeutic method of providing therapeutic auditory, visual, and/or tactile stimulus, according to several embodiments;

[0032] FIG. 5 is a front right perspective view of a second embodiment therapeutic wearable headset or sleep mask;

[0033] FIG. 6 is a top right exploded view of the therapeutic wearable headset or sleep mask of FIG. 5;

[0034] FIG. 7A, 7B, and 7C are a bottom right perspective view, a rear view, and a left view, respectively, of a third embodiment therapeutic wearable headset or sleep mask;

[0035] FIG. 8 is an exploded front view of the embodiment of FIG. 7A.

MODE(S) FOR CARRYING OUT THE INVENTION

[0036] FIGURE 1A is a schematic diagram of a first embodiment therapeutic system **100**. Therapeutic system **100** provides one or more outputs that a person wearing the therapeutic system may experience as auditory, visual, and/or tactile stimulus. Thus, in one embodiment, therapeutic system may comprise a left light source **110L**, a right light source **110R**, a left vibration source **120L**, a right vibration source **120R**, and a controller **130** for independently controlling and coordinating the action of the light and vibration sources. Thus, for example, therapeutic system **100** may be positioned on the head of a user with left light source **110L** positioned over the left eye to provide a left visual stimulus, right light source **110R** positioned over the right eye to provide a right visual stimulus, left vibration source **120L** positioned to provide left ear auditory stimuli, and right vibration source **120R** positioned to provide right ear auditory stimuli.

[0037] In one embodiment, left and right light sources **110L**, **110R** may each comprise light-emitting diodes, an incandescent light source having a wavelength filter, a fluorescent light source, a backlit LCD panel, or other light source configured to provide to the user light at a desired, predetermined wavelength or wavelength range.

[0038] In certain embodiments, left and right light sources **110L**, **110R** are separately controlled to provide output at a stimulation frequency comprising alternating between a high stimuli, where the light sources are activated (or “on”) and where the light sources have a lower, or no activation (both referred to herein as being “off”). The alternating may, for example and without limitation, be in the form of a square wave, a triangular shape wave, a sine wave, or some other waveform.

[0039] The alternating may, for example and without limitation, be in the form of a square wave, a triangular shape wave, a sine wave, or some other waveform.

[0040] Thus, for example and without limitation, a light source may be programmed to provide an output of light that alternates between a high light level (a high stimuli) and a lower light level (a low stimuli) at a rate, or stimulation frequency of between 1.0 and 42 Hz.

[0041] In one embodiment, left and right vibration sources **120L**, **120R** may each comprise earbuds, miniature speakers, or other vibration sources that can provide auditory stimuli to a user. In certain other embodiments, left and right vibration sources **120L**, **120R** may comprise bone conduction transducers in the audible frequency range to provide vibrations to the user’s skull bone that is sensed as auditory by the user’s ear. Optionally, one or more of left and right

vibration sources **120L**, **120R** may also produce vibrations that are sensed as tactile stimuli. Thus, for example, controller **130** may provide first signals to bone conduction transducers that vibrate or oscillate at a first frequency that can be interpreted by the user as auditory stimuli and may provide second signals at a second, lower frequency that can be interpreted as a tactile sensation by the user. In other words, bone conduction transducers may be adapted to provide both auditory and tactile stimulus to the user.

[0042] In certain embodiments, left and right vibration sources **120L**, **120R** provide output at specific one or more frequencies or a range of frequencies. In one embodiment, left and right vibration sources **120L**, **120R** are separately controlled to provide output at a stimulation frequency comprising alternating between a high stimuli, where the vibration sources are activated (or “on”) and where the vibration sources have a lower, or no activation (or “off”). In certain embodiments, left and right light sources **110L**, **110R** are separately controlled to provide output at a stimulation frequency comprising alternating between a high stimuli, where the light sources are activated (or “on”) and where the light sources have a lower activation, or no activation (both referred to herein as being “off”). The alternating may, for example and without limitation, be in the form of a square wave, a triangular shape wave, a sine wave, or some other waveform.

[0043] In one embodiment, the intensity of the high and low stimuli of light and vibration, the stimulation frequency, and the time over which the stimulation is provided are controlled by controller **130** in differing stimulation patterns. The stimulation patterns may include, but are not limited to: 1) all of the stimuli being synchronous (the high and low stimuli occurring at the same time); or 2) pairs of stimuli being synchronous and out of phase with other pairs of stimuli. Examples of pairs of stimuli being synchronous and out of phase with other pairs of stimuli include: a) the first pair being left side light and vibration and the second pair being right side light and vibration; b) the first pair being left side light and right side light and the second pair being right side vibration and left side vibration; and c) the first pair being left side light and right side vibration and the second pair being right side vibration and left side light.

[0044] In one embodiment, the intensity of the high and low vibration and light stimuli, the stimulation frequency, and the time over which the stimulation is provided are controlled by controller **130**.

[0045] Thus, for example and without limitation, a vibration source may be programmed to provide an output at an audio frequency of 256 Hz that alternates between a high vibration level (a high stimuli) and a lower vibration level (a low stimuli) at a rate, or stimulation frequency of

between 1.0 and 42 Hz. Thus, in this example, the vibration source is the product of an audio frequency and a square wave.

[0046] Therapeutic system **100** also includes a sensor assembly **150** that obtains one or more measurements from the user of the therapeutic system. Thus, for example and without limitation, sensor assembly **150** may include, or is in communication with, a sensor that measures some property or characteristic of the user, including but not limited to, heart rate, heart rate variability, body temperature, or blood pressure, and includes electronics that provide a signal indicative of the measurement to controller **130**. In other embodiments, one or more sensors are connected to sensor assembly **150** by wired or wireless connectors. Thus, in various embodiments, the sensors may include one or more: electrodes for sensing electrical activity in the brain, as in a 2 or 4 lead EEG, a temperature sensor, and/or a heartbeat sensor, or one or more EMG sensors positioned, for example and without limitation, to measure eye movement to ascertain when REM sleep is reached, and/or to measure muscle tone to aid in determining states of relaxation. Controller **130** may utilize the signal from sensor assembly **150** to modify the intensity and/or timing of the light and vibration sources.

[0047] In one embodiment controller **130** includes: an output **131** to provide signals to actuate light sources **110L** and **110R**, vibration sources **120L** and **120R**, and any other components that provide sensory input to the user; an input **132** to accept signals from sensor assembly **150**; a non-transitory memory **133** for storing programming and data for system **100**; a processor **134**; and a communications module **135**. Memory **133** includes instructions that are accessible to processor **134** for operating the components that provide sensory input to the user, including but not limited to light sources **110L** and **110R**, vibration sources **120L** and **120R**, including accepting input provided to input **132** and modifying signals provided to components that provide sensory input to the user, including but not limited to light sources **110L** and **110R**, vibration sources **120L** and **120R**. Communications module **135** provides for the transfer of information to or from controller **130** by wired or wireless means.

[0048] FIGURE 1B is a schematic diagram of a second embodiment therapeutic system **100'**. Second embodiment therapeutic system **100'** is generally similar to first embodiment therapeutic system **100**, except as explicitly noted. Specifically, second embodiment therapeutic system **100'** includes a left tactile stimulus source **121L** and a right tactile stimulus source **121R**, each of which may be individually controlled and coordinated with the controller **130** to provide tactile stimuli to a user of therapeutic system **100'**.

[0049] FIGURES 2A and 2B show schematic diagrams of the controller **130** of therapeutic system **100** or **100'**. As shown in FIG. 2A, therapeutic system **100** or **100'** may optionally include an external control unit **130a** that may wirelessly communicate with a wireless receiver/transmitter **130c** of the controller **130** through a wireless connection **131a**. The wireless connection **131a** may comprise a Bluetooth connection, a Bluetooth LE connection, a WiFi connection, a ZigBee connection, an infrared (IR) connection, a radiofrequency (RF) connection, or an inaudible auditory signal connection, to name a few examples. The external control unit **130a** may comprise a custom-built, electronic controller. In many embodiments, the external control unit **130a** may comprise a personal computing device of the user that may have downloaded onto and operating, a custom computer application or “app” to operate the system **100** or **100'** to provide a therapeutic regimen. For example, the personal computing device may comprise a personal computer, a personal laptop computer, a tablet computer (such as an Apple iPad, a Samsung Galaxy Tab, a Microsoft Surface, or an Amazon Fire, to name a few examples), a smartphone (such as an Apple iPhone, a Samsung Galaxy phone, or a Google Nexus phone, to name a few examples), and the custom computer application or “app” may be an application or “app” downloadable from an application distribution platform such as Apple iTunes, Apple Store, Google Play, Google Chrome Web Store, Amazon App Store, or Microsoft Windows Store, to name a few examples. The application may include one or more therapeutic regimens that the user may select for implementation by the therapeutic system **100** or **100'**. In some embodiments, the application may allow the user to provide feedback information about the efficacy of the therapeutic regimen(s), the feedback may be uploaded and collected by a central server(s) in communication with the application, and the therapeutic regimen(s) may be improved or optimized based on the feedback from the one or more users. Alternatively, or in combination, as shown in FIG. 2B, the system **100** or **100'** may further comprise an external control unit **130a**, such as a custom-built controller, that may communicate with the controller **130** through a wired connection **131a**, for example, a USB, FireWire, or Lightning connection, to name a few examples.

[0050] FIGURE 3A shows one embodiment of therapeutic system **100** as including a first embodiment therapeutic wearable headset or sleep mask **140** which integrates the light, vibration, and, optionally, tactile sources into a single form factor for presentation to a user. Thus, for example, when a user places wearable headset or sleep mask **140** on their head, left light source **110L** is positioned over the left eye to provide a left visual stimulus, right light source **110R** is positioned over the right eye to provide a right visual stimulus, left vibration source **120L** is positioned to provide left ear auditory stimuli, and right vibration source **120R** is positioned to provide right ear auditory stimuli.

[0051] As discussed above and herein, the left vibration source **120L** and the right vibration source **120R** may each comprise bone conduction transducer that may provide both auditory and tactile stimulus. Alternatively, wearable headset or sleep mask **140** is therapeutic system **100** which includes left tactile stimulus source **121L** and right tactile stimulus source **121R**, each of which may be individually controlled and coordinated with the controller **130**, as described above regarding FIG. 1B.

[0052] As discussed above and herein, the therapeutic wearable headset or sleep mask **140** may be operated with an external controller **130a** (e.g., a smartphone) in communication with the controller **130** through a wireless connection **131a**, for example. The user **US** may have an option to turn tactile stimulation on or off, for example. FIG. 3B shows a user **US** wearing the therapeutic wearable headset or sleep mask **140**.

[0053] Figure 5 is a front right perspective view and Figure 6 is a top right exploded view of a second embodiment therapeutic wearable headset or sleep mask **500**. Headset **500** is generally similar to headset **140**, except as explicitly stated.

[0054] As shown in FIGS. 5 and 6, headset **500** includes a cover **510**, sensor assembly **150**, controller **130**, light sources **110L** and **110R**, and vibration sources **120L** and **120R**. Sensor assembly **150** may include a biometric sensor system, such as that which is sold under the name of VALENCELL BENCHMARK™ (Raleigh, NC), that includes an infrared light source and detector, which can be used to detect heart rate using pulse oximetry, an accelerator, and a processing unit. Sensor assembly **150** includes a sensor module circuit board that contains a digital optical detector system. This detector controls the LEDs and converts the optical signals reflected from the user's skin to digital format and communicates over the internal I2C bus to the PerformTek® processor. The accelerometer is also read via the internal I2C bus for activity signal.

[0055] Controller **130** may include, for example and without limitation, a Nordic Semiconductor ASA (Oslo, Norway) model NRF51822 Multiprotocol BLUETOOTH® low energy/2.4 GHz RF System on Chip, and a VLSI Solution (Tampere, Finland) model VS1000 audio module.

[0056] Light sources **110L** and **110R** may include, for example and without limitation, Lite-On, Inc. (Milpitas, CA) Bin G3/W2/AU model LTST-020VSKT LEDs. Vibration sources **120L** and **120R** are Basen Technology Co, Ltd model PN: OEM-E170a earbuds.

[0057] Sensor assembly **150** may include, for example and without limitation, a PerformTek® processor which polls sensor data over the internal I2C bus and converts the raw measurements into data registers of biometric values (i.e. Heart Rate, Cadence, VO2) and processes those values further into higher level user assessments (i.e. Calories Burned, Distance, VO2 max, fitness level, and the period between heart rate beats (the Heart Rate Interval, or RR Interval)). The PerformTek® processor runs algorithms to convert the raw signals to a register array of biometric values and high-level assessments. These values are available for reading via the UART or I2C firmware interface. In addition, sensor module diagnostics such as signal quality, error codes, and serial number ID are available.

[0058] Sensor assembly **150** further includes control lines for interfacing controller **130** with the PerformTek® processor include a Power On Self-Test (POST), UART or I2C communication interface, and a wake-from-standby line (WAKE). The host processor can control much of the functionality of the sensor module via a software protocol interface over the UART or I2C interface.

[0059] In one embodiment, sensor assembly **150** determines a current Heart Rate, which is provided to controller **130**. In another embodiment, sensor assembly **150** also provides accelerometer data to controller **130**.

[0060] In yet another embodiment, sensor assembly **150** includes one or more EEG sensors, as are known in the field, and provides brain electrical activity measurements to controller **130**.

[0061] In another embodiment, sensor assembly **150** includes one or more EMG sensors positioned, for example and without limitation, to measure eye movement to ascertain when REM sleep is reached, and/or to measure muscle tone to aid in determining states of relaxation. EMG sensors, as are known in the field, and provides brain electrical activity measurements to controller **130**.

[0062] Figures 7A, 7B, and 7C are a bottom right perspective view, a rear view, and a left view, respectively, and Figure 8 is an exploded front view of a third embodiment therapeutic wearable headset or sleep mask **700**. Headset **700** is generally similar to headset **500**, except as explicitly stated.

[0063] Headset **700** differs from headset **500** in that headset **700** includes left and right audio jacks **701L** and **701R** into which left and right earbuds **120L** and **120R**, respectively, may be plugged into. Alternatively, stereo headphones (not shown) may be plugged into one of jacks

701L or 701R, where the jacks are appropriately programmed to provide stereo sound to the headphones.

[0064] FIGURE 4 shows a flow chart of an exemplary therapeutic method **400** for providing therapeutic auditory, visual, and/or tactile stimulus. In a step **410**, a subject having a neurological disorder or condition may be identified. Examples of neurological disorders may include, but are not limited to, insomnia, post-traumatic stress disorder (PTSD), brain injuries such as traumatic brain injury (TBI), mild traumatic brain injury (mTBI), or injuries to the brain due to oxygen deprivation, such as strokes, depression, anxiety, mood disorders, personality disorders, eating disorders, and psychotic disorders. Alternatively, a subject may be selected to undergo a therapeutic method **400** for the purpose of performance enhancement of mental and/or physical tasks for to aid the subject in napping or sleeping. In a step **420**, the subject may be provided the therapeutic system or headwear, such as the system **100** or **100'** described above. In a step **430**, the subject may wear the therapeutic system or headwear, such as wearable headset or sleep mask **140**, **500**, or **700**. In a step **440**, headset **140** executes programming **450** provided in controller **130** to provide stimuli to the subject. The programming provides two or more of auditory, visual, and/or tactile stimulus are concurrently provided by headset **140** to the subject, and thus, for example, may provide power to activate left light source **110L**, right light source **110R**, left vibration source **120L** and or right vibration source **120R**. The programming also includes modifying the auditory, visual, and/or stimuli in response to measurements obtained by sensor assembly **150** and provided to controller **130**.

[0065] As discussed above and herein, the left vibration source **120L** and the right vibration source **120R** may each comprise bone conduction transducer that may provide both auditory and tactile stimulus. Alternatively, wearable headset or sleep mask **140** **500**, or **700** is therapeutic system **100'** which includes left tactile stimulus source **121L** and right tactile stimulus source **121R**, each of which may be individually controlled and coordinated with the controller **130**, as described above regarding FIG. 1B.

[0066] In certain embodiments, providing two or more of auditory, visual, and/or tactile stimulus concurrently may provide improved therapeutic benefits as compared to providing only one of auditory, visual, or tactile stimulus at one time. The two or more auditory, visual, and/or tactile stimulus may thus combine to provide the improved therapeutic benefits, for example (i.e., the two or more auditory, visual, and/or tactile stimulus may synergize in a way to provide improved results over providing two of the stimuli individually.)

[0067] Exemplary instructions for providing stimuli may be provided, for example, by programming **450**, which includes one or more subroutines. One such subroutine is subroutine **450e**, which analyzes measurements obtained from sensor assembly **150** and stores the analyzed measurements in memory **113**. Subroutine **450a** includes instructions for the simultaneous activation of all active auditory, visual, and/or tactile stimulus sources. Optionally, the activation of all sources may include the activation of tactile stimulation to run throughout all subsequent auditory and/or visual stimulation. Another exemplary subroutine **450b** may include instructions for alternating the left auditory, visual, and/or tactile stimulus sources with the right auditory, visual, and/or tactile stimulus sources (i.e., the left stimuli and right stimuli take turns being active.) Another exemplary subroutine **450c** may include instructions for alternating the visual sources with the auditory and/or tactile sources (i.e., the visual stimuli and the auditory/tactile stimuli take turns being active.) Another exemplary subroutine **450d** may include instructions for alternating the left auditory and/or tactile source and the right visual source with the right auditory and/or tactile source and the left visual source (i.e., opposite auditory/tactile stimuli take turns being active.).

[0068] In certain embodiments, one or more of subroutines **450a**, **450b**, **450c**, or **450d**, access the analyzed measurements from subroutine **450e** and modifies the instructions they provide to the auditory, visual, and/or tactile stimuli depending on real-time or near real-time measurements of the user obtained from sensor assembly **150**. Such programming is further described below.

[0069] In step **440**, programming **450**, including by not limited to subroutines **450a**, **450b**, **450c**, and **450d**, may each be applied one or more times, individually or in combination with one another. The programming may, in addition, provide sequences of output in subroutines **450a**, **450b**, **450c**, and **450d** at different frequencies and/or timings. Thus, for example the subroutines may provide output at specific frequencies that change as the subroutine is repeated. Thus, for example, subroutine **450a** may provide auditory output to vibration source **120R** or **120L** at a frequency of 256 Hz that is turned on and off, that is it is pulsed, at a pulse frequency of 1 Hz for 2 minutes. This square pulse auditory signal thus generates signals at a frequency of 1 Hz in addition to higher harmonics. At a subsequent time, the output at 256 Hz is pulsed at twice the previous pulse frequency for 2 minutes. In this manner, the auditory frequency of 256 Hz may be modulated over a wide range, including frequencies corresponding to brain wave frequencies.

[0070] In addition, by alerting the output between left and right channels, the brain may be stimulated in a way that it is forced to communicate between the left and right sides of the brain.

This forced communication, for example, can allow PTSD memories to be wired to both sides of the brain, thereby stopping undesirable flashbacks.

[0071] In step 440, subroutine 450e receives measurements from sensor assembly 150 and stores analyzed measurements. In one embodiment, sensor assembly 150 provides instantaneous, or nearly instantaneous, measurements from the user. Thus, for example and without limitation, sensor assembly 150 provides a sequence of measurements of beat-to-beat intervals of the heart of the user, that is, the time interval between the last two heart beats, which is also referred to, without libation, as the NN intervals. Controller 130 then computes and stores values of the heart rate variability (HRV), which is a mathematical representation of the physiological phenomenon of variation in the time interval between heartbeats.

[0072] In another embodiment, sensor assembly 150 provides accelerometer data, which is stored by controller 130 and used to modify stimuli to the user. The accelerometer provides data on the movement of the user and is used to provide information related to the user's respiration rate and eye movement. The accelerometer is sensitive to movement of the wearer and in certain embodiment provides an indication of eye motion. The accelerometer may be calibrated to determine signals that correspond to REM sleep, which may be stored in memory 133. The accelerometer information may then be used by controller 130 to determine if the user is experiencing REM sleep. When this is found to be the case, controller 130 may reduce the brightness and/or volume of the stimuli at a rate, for example, of 20% every 20 secs, until the light and/or sound are turned off.

[0073] In yet another embodiment, sensor assembly 150 includes a thermocouple or other temperature sensor that provides data on the temperature of the user, which is stored by controller 130 and which is used determine a stage of sleep of the user. The thermocouple may be calibrated to determine signals that correspond to REM sleep, which may be stored in memory 133. The temperature measurement may then be used by controller 130 to determine if the user is experiencing REM sleep. When this is found to be the case, controller 130 may reduce the brightness and/or volume of the stimuli at a rate, for example, of 20% every 20 sec, until the light and/or sound are turned off.

[0074] In another embodiment, sensor assembly 150 provides EEG data from the user, which is stored by controller 130 and which is used to modify stimuli to the user. The EEG data may be used to determine how relaxed the user is and if there is any hemispheric imbalance. Thus, for example, if the EEG data indicates that one side of the brain is consistently more active than the other side, the stored EEG data can be used to increase stimuli to that other side of the brain.

[0075] In one embodiment, a time-domain calculation of NN intervals is used to compute the HRV. Thus, for example, the sequence of NN intervals (“NN_i”) is accepted from sensor assembly **150** and stored in memory **133**. After the accumulation NN_i for a period of time, T, the HRV is calculated as approximated by the root mean square of successive differences between adjacent NNs, or RMSSD. Thus, at a time T from the beginning of the accumulation of data, if N consecutive NN intervals are stored in memory **133**, the following calculation is performed in processor **134** according to a program stored in the memory:

$$RMSSD = \sqrt{\frac{1}{N-1} (\sum_{i=1}^{N-1} (NN_{i+1} - NN_i)^2)}$$

[0076] The initial value of RMSSD (that is, RMSSD₀) is stored in memory **133** as a baseline. Thereafter, at the end of each period T, the calculation of RMSSD is repeated covering that time period. As a result, a sequence of RMSSD_j values are computed. Next the difference between the current RMSSD value and the baseline RMSSD₀ is computed as ΔRMSSD_j = RMSSD_j - RMSSD₀. ΔRMSSD is a measure of the change between the current HRV and the baseline, initial HRV.

[0077] In general, it is realized by those skilled in the art, that an increased in HRV is associated with a relaxed state, or a sleep state, and that a decrease in HRV is associated with a less relaxed, or stressed, state. For uses of therapeutic system **100** intended to calm a person or to induce sleep, a positive ΔRMSSD indicates that the person is becoming relaxed and that the system is working as intended. A negative ΔRMSSD indicates that the person is not becoming more relaxed. In one embodiment, an indication that the person is relaxed (ΔRMSSD > 0) is used to modify the treatment by reducing the treatment time and/or intensity of the stimuli, and an indication that the person is less relaxed (ΔRMSSD < 0) is used to modify the treatment to increase the treatment time and/or the intensity of the stimuli.

[0078] Thus, for example an without limitation, if -10% < ΔRMSSD < +10%, no change is made to the stimuli, if ΔRMSSD > +10%, then the treatment time and/or stimuli is decreased (for example by decreasing the time and/or intensity of stimuli by 10%), and if ΔRMSSD < -10%, then the treatment time and/or stimuli is increased (for example by increasing the time and/or intensity of stimuli by 10%).

[0079] The calculations described above are provided by way of explanation, and are not meant to limit the scope of the calculations or how the operation of therapeutic system **100** is or is not modified using HRV measurements.

[0080] Although the above steps show method **400** of treating a patient in accordance with embodiments, a person of ordinary skill in the art will recognize many variations based on the teaching described herein. The steps may be completed in a different order. Steps may be added or deleted. Some of the steps may comprise sub-steps. Many of the steps may be repeated as often as beneficial to the treatment.

[0081] One or more of the steps of the method **400** may be performed with the circuitry as described herein, for example, circuitry of the controller **130** or the external control unit **130a** such as one or more of a processor or logic circuitry such as a central processing unit (CPU) or a programmable array logic for field programmable gate array. The circuitry may be programmed to provide one or more of the steps of the method **400**, and the program may comprise program instructions stored on a computer readable memory or programmed steps of the logic circuitry such as the programmable array logic or the field programmable gate array, for example.

EXAMPLE 1

[0082] The following describes an example of a stimulation pattern that has been found by empirical studies to be effective for inducing sleep, including napping, increasing neuroplasticity, treating brain injuries from strokes, TBI, or mTBI, improving balance, including improving fine motor control and reaction times, and treating PTSD, to name a few indications.

[0083] Light and auditory stimulus at a first frequency may be provided for a first time segment, then at a second lower frequency for a second time segment, and then at a third lower frequency for a third time segment. Each time segment may include one or more sub-segments of light and auditory stimulus, each sub-segment comprising one of the subroutines described above, for example. The light and auditory stimulus may end after a pre-determined time period, such as 20 minutes. The light and auditory stimulus may be ramped back up (i.e., starting from the third frequency, then transitioning to the second frequency, and finally transitioning to the first frequency), such as to wake the user. Alternatively or in combination, the light and auditory stimulus may be maintained at the second frequency such as to maintain a sleep state of the user. As described above, tactile stimulus may be provided concurrently with the auditory stimulus. The light may be provided at a wavelength of 580 nm and the auditory having a frequency of 256 Hz may be provided, or any of a number of auditory frequencies or combinations thereof that the subject can select as they wish.

[0084] Table 1 below describes an exemplary treatment regimen for this example. The stimulation provided in Table 1 first cycles through a block of four Segment A outputs, then

cycles through a block of four Segment B outputs, then cycles through seven blocks of four Segment C outputs, and lastly repeats the block of four Segment A outputs. For Segment A outputs (A1, A2, A3, and A4), the auditory and light outputs cycle 115 or 116 times between being on for 0.1277 seconds and then being off for 0.1277 seconds (that is, at a pulse frequency of 3.9 Hz), followed by no output for 0.5 seconds. For Segment B outputs (B1, B2, B3 and B4), the auditory and light outputs cycle 44 or 45 times between being on for 0.3333 seconds and then being off for 0.3333 seconds (that is, at a pulse frequency of 1.5 Hz) followed by no output for 0.5 seconds. For Segment C outputs (C1, C2, C3 and C4), the auditory and light outputs cycle 14 or 15 times between being on for 1 second and then being off for 1 second (that is, a pulse frequency of 0.5 Hz), followed by no output for 1 second. Segments A1, B1, and C1 pulse the right and left sides of both the light and auditory together, with all outputs are synchronized to be on or off at the same time, as provided by subroutine **450a**. Segments A2, B2, and C2 synchronize the left side light and auditory output, and the right side light and auditory output to be opposite to one another, as provided by subroutine **450b**. Segments A3, B3, and C3 synchronize both lights together to be opposite to both auditory outputs, as provided by subroutine **450c**. Segments A4, B4, and C4 synchronize the right auditory and light to be opposite to the left auditory and light outputs, as provided by subroutine **450d**.

[0085] In one embodiment, subroutine **450e** uses heart rate data to modify the treatment shown in Table 1 as follows. Table I lists a temporal sequence of stimuli. During the execution of each segment, if the current value of ΔRMSSD falls within $-10\% < \Delta\text{RMSSD} < +10\%$, then the segment is followed as listed in Table 1. If during each segment the current value of ΔRMSSD is greater than $+10\%$, then the treatment time and/or stimuli is decreased. This may be accomplished, for example and without limitation, by decreasing the length of time of the current segment by 10%, and/or by decreasing the amplitude of the stimuli (that is, the intensity of stimuli provided to the user) by 10%. If during each segment the current value of ΔRMSSD is less than -10% , then the treatment time and/or stimuli is increased. This may be accomplished, for example and without limitation, by increasing the length of time of the current segment by 10%, and/or by increasing the amplitude of the stimuli (that is, the intensity of stimuli provided to the user) by 10%.

[0086] In another embodiment, sensor assembly **150** provides accelerometer data, which is stored by controller **130** and used to modify stimuli to the user by aiding in the detection of REM sleep where HRV data alone might be insufficient to determine the relaxation state of the users. In yet another embodiment, sensor assembly **150** provides data on the temperature of the user, which is stored by controller **130** and which is used to modify stimuli to the user. The

temperature data is used to refine the sleep staging and modifying the stimuli accordingly. Thus, for example, a lower temperature indicates deeper sleep level, and the stimuli is modified to reduce the intensity of the light and audio. Further, sub-patterns having the greatest relaxation effects are prioritized, and may, for example, reduce the light and/or sound intensity 10%, finish the sub-pattern, and continue to repeat the sub-pattern until the HRV level indicates that the person is asleep.

[0087] In another embodiment, sensor assembly 150 provides EEG data from the user, which is stored by controller 130 and which is used to modify stimuli to the user. The EEG data may be used to determine how relaxed the user is and if there is any hemispheric imbalance. Thus, for example, if the EEG data indicates that the right side of the brain is consistently more active than the stored EEG data can be used to increase stimuli to the opposite side of the brain. This measuring of hemispheric imbalance can also be used as a measure of recovery from concussion, TBI and mTBI. And as a proxy for likely improvements in balance, fine motor skills and reaction speeds, all of which are hampered by hemispheric imbalance.

TABLE 1

	Auditory Left	Auditory Right	Light Left	Light Right
Segments A1-A4 for 120s				
Segment A1 (Light and Auditory both sides pulse together) Repeat 116 times, followed by 0.5 sec gap	On 0.1277s	On 0.1277s	On 0.1277s	On 0.1277s
	Off 0.1277s	Off 0.1277s	Off 0.1277s	Off 0.1277s
Segment A2 (light and auditory on left side, alternating light and auditory on Right). Repeat 116 times, followed by 0.5 sec gap	On 0.1277s	Off 0.1277s	On 0.1277s	Off 0.1277s
	Off 0.1277s	On 0.1277s	Off 0.1277s	On 0.1277s
Segment A3 (both lights together, alternating with both auditory signals together) Repeat 115 times, followed by 0.5 sec gap	On 0.1277s	On 0.1277s	Off 0.1277s	Off 0.1277s
	Off 0.1277s	Off 0.1277s	On 0.1277s	On 0.1277s
Segment A4 (auditory left and light right together, alternating auditory right and light left together) Repeat 115 times, followed by 0.5 sec gap	On 0.1277s	Off 0.1277s	Off 0.1277s	On 0.1277s
	Off 0.1277s	On 0.1277s	On 0.1277s	Off 0.1277s

TABLE 1 (Continued)

	Auditory Left	Auditory Right	Light Left	Light Right
Segments B1-B4 for 120s				
Segment B1 (Light and Auditory both sides pulse together) Repeat 45 times, followed by 0.5 sec gap	On 0.3333s	On 0.3333s	On 0.3333s	On 0.3333s
	Off 0.3333s	Off 0.3333s	Off 0.3333s	Off 0.3333s
Segment B2 (light and auditory on left side, alternating light and auditory on Right) Repeat 44 times, followed by 0.5 sec gap	On 0.3333s	Off 0.3333s	On 0.3333s	Off 0.3333s
	Off 0.3333s	On 0.3333s	Off 0.3333s	On 0.3333s
Segment B3 (both lights together, alternating with both auditory signals together) Repeat 44 times, followed by 0.5 sec gap	On 0.3333s	On 0.3333s	Off 0.3333s	Off 0.3333s
	Off 0.3333s	Off 0.3333s	On 0.3333s	On 0.3333s
Segment B4 (auditory left and light right together, alternating auditory right and light left together) Repeat 44 times, followed by 0.5 sec gap	On 0.3333s	Off 0.3333s	Off 0.3333s	On 0.3333s
	Off 0.3333s	On 0.3333s	On 0.3333s	Off 0.3333s
Repeat the following Segments C1-C4 7 times for a total of 14 minutes				
Segment C1 (Light and Auditory both sides pulse together) Repeat 15 times, followed by 1 sec gap	On 1 sec	On 1 sec	On 1 sec	On 1 sec
	Off 1 sec	Off 1 sec	Off 1 sec	Off 1 sec
Segment C2 (light and auditory on left side, alternating light and auditory on Right) Repeat 15 times, followed by 1 sec gap	On 1 sec	Off 1 sec	On 1 sec	Off 1 sec
	Off 1 sec	On 1 sec	Off 1 sec	On 1 sec
Segment C3 (both lights together, alternating with both auditory signals together) Repeat 14 times, followed by 1 sec gap	On 1 sec	On 1 sec	Off 1 sec	Off 1 sec
	Off 1 sec	Off 1 sec	On 1 sec	On 1 sec
Segment C4 (auditory left and light right together, alternating auditory right and light left together) Repeat 14 times, followed by 1 sec gap	On 1 sec	Off 1 sec	Off 1 sec	On 1 sec
	Off 1 sec	On 1 sec	On 1 sec	Off 1 sec
	Off 1 sec	On 1 sec	On 1 sec	Off 1 sec

TABLE 1 (Continued)

Segments A1-A4 for 120s	Auditory Left	Auditory Right	Light Left	Light Right
Segment A1 (Light and Auditory both sides pulse together) Repeat 116 times, followed by 0.5 sec gap	On 0.1277	On 0.1277	On 0.1277	On 0.1277
	Off 0.1277	Off 0.1277	Off 0.1277	Off 0.1277
Segment A2 (light and auditory on left side, alternating light and auditory on Right) Repeat 116 times, followed by 0.5 sec gap	On 0.1277	Off 0.1277	On 0.1277	Off 0.1277
	Off 0.1277	On 0.1277	Off 0.1277	On 0.1277
Segment A3 (both lights together, alternating with both auditory signals together) Repeat 115 times, followed by 0.5 sec gap	On 0.1277	On 0.1277	Off 0.1277	Off 0.1277
	Off 0.1277	Off 0.1277	On 0.1277	On 0.1277
Segment A4 (auditory left and light right together, alternating auditory right and light left together) Repeat 115 times, followed by 0.5 sec gap	On 0.1277	Off 0.1277	Off 0.1277	On 0.1277
	Off 0.1277	On 0.1277	On 0.1277	Off 0.1277

EXAMPLE 2

[0088] The following describes an example of a stimulation pattern that has been found by empirical studies to be effective for inducing sleep. The stimulation pattern of Example 2 includes the part of the treatment regimen shown in Table 1. Specifically, the stimulation first cycles through a block of four Segment A outputs, then cycles through a block of four Segment B outputs, and then cycles through seven blocks of four Segment C outputs. The repetition of the last block of four Segment A outputs is not provided in Example 2.

[0089] The modification of the segments using subroutine **450e** is the same as in Example 1.

EXAMPLE 3

[0090] The following described example of a stimulation pattern that has been found by empirical studies to be effective for increasing alpha wave brain activity, inducing neuroplasticity, treating stroke or other brain injuries such as TBI, mTBI, including improving balance, improving fine motor control and reaction times, and treating PTSD, to name a few indications.

[0091] HRV is used in the case of TBI and mTBI and PTSD as well – typically a relaxation effect is measured after the device has induced neuroplasticity – the stimulus is maintained at a standard level until that relaxation effect is measured, and then the device shifts towards a sleep modality to help improvements in balance that have occurred.

[0092] In this example, the four subroutines described above and herein are applied and repeated for multiple time segments, each at a predetermined stimulation (repetition) frequency. The four subroutines may be repeated, such as with each segment of the four subroutines lasting 120 seconds, for example. As described above, tactile stimulus may be provided concurrently with the auditory stimulus. The light may be provided at a wavelength of 580 nm and the auditory having a frequency of 432 Hz may be provided.

[0093] Table 2 below describes an exemplary treatment regimen for this example. The stimulation provided in Table 2 cycles through a block of four Segment A outputs 10 times. For Segment A1, A2, A3, and A4, the auditory and light outputs cycle 115 or 116 times between being on for 0.1277 seconds and then being off for 0.1277 seconds, followed by no output for 0.5 seconds. Segment A1 pulses the right and left sides of both the light and auditory together, with all outputs are synchronized to be on or off at the same time, as provided by subroutine **450a**. Segment A2 synchronizes the left side light and auditory output, and the right side light and auditory output to be opposite to one another, as provided by subroutine **450b**. Segment A3 synchronizes both lights together to be opposite to both auditory outputs, as provided by subroutine **450c**. Segment A4 synchronizes the right auditory and light to be opposite to the left auditory and light outputs, as provided by subroutine **450d**.

TABLE 2

	Auditory Left	Auditory Right	Light Left	Light Right
Repeat the following Segments A1-A4 10 times for a total time of 20 minutes				
Segment A1 (Light and Auditory both sides pulse together) Repeat 116 times, followed by 0.5 sec gap	On 0.1277s	On 0.1277s	On 0.1277s	On 0.1277s
	Off 0.1277s	Off 0.1277s	Off 0.1277s	Off 0.1277s
Segment A2 (light and auditory on left side, alternating light and auditory on Right) Repeat 116 times, followed by 0.5 sec gap	On 0.1277s	Off 0.1277s	On 0.1277s	Off 0.1277s
	Off 0.1277s	On 0.1277s	Off 0.1277s	On 0.1277s
Segment A3 (both lights together, alternating with both auditory signals together) Repeat 115 times, followed by 0.5 sec gap	On 0.1277s	On 0.1277s	Off 0.1277s	Off 0.1277s
	Off 0.1277s	Off 0.1277s	On 0.1277s	On 0.1277s
Segment A4 (auditory left and light right together, alternating auditory right and light left together) Repeat 115 times, followed by 0.5 sec gap	On 0.1277s	Off 0.1277s	Off 0.1277s	On 0.1277s
	Off 0.1277s	On 0.1277s	On 0.1277s	Off 0.1277s

EXAMPLE 4

[0094] The following described yet another example of a stimulation pattern that has been found by empirical studies to be effective for increasing energy levels in the subject. Light and auditory stimulus at a first frequency may be provided for a first time segment, then at a second higher frequency for a second time segment, then back at the first frequency for a subsequent time segment, and so forth. Each time segment may include one or more sub-segments of light and auditory stimulus, each sub-segment comprising one of the sub-routines described above, for example. The light and auditory stimulus may end after a pre-determined time period, such as 20 minutes. As described above, tactile stimulus may be provided concurrently with the auditory stimulus. The light may be provided at a wavelength of 580 nm and the auditory having a frequency of 432 Hz may be provided.

[0095] HRV is used to determine the effectiveness of the stimulation – when HRV drops, it indicates an arousal effect, and in the exact reversal of sleep induction, in this mode, where arousal effect is noted in some sub-routines more than others, then these sub-routines are prioritized. When it is desired to wake up the user, the time of a sub-segment for increasing arousal may be increased.

[0096] Table 3 below describes an exemplary treatment regimen for this example. The stimulation provided in Table 3 cycles ten times first through a block of four Segment A outputs, then through a block of four Segment D outputs. For Segment A outputs (A1, A2, A3, and A4), the auditory and light outputs cycle 115 or 116 times between being on for 0.1277 seconds and then being off for 0.1277 seconds, followed by no output for 0.5 seconds. For Segment D outputs (D1, D2, D3 and D4), the auditory and light outputs cycle 44 or 45 times between being on for 0.0667 seconds and then being off for 0.0667 seconds, followed by no output for 0.5 seconds. Segments A1 and D1 pulse the right and left sides of both the light and auditory together, with all outputs are synchronized to be on or off at the same time, as provided by subroutine **450a**. Segments A2 and D2 synchronize the left side light and auditory output, and the right side light and auditory output to be opposite to one another, as provided by subroutine **450b**. Segments A3 and D3 synchronize both lights together to be opposite to both auditory outputs, as provided by subroutine **450c**. Segments A4 and D4 synchronize the right auditory and light to be opposite to the left auditory and light outputs, as provided by subroutine **450d**.

TABLE 3

	Auditory Left	Auditory Right	Light Left	Light Right
Repeat 10 times: Segments A1-A4 followed by Segments D1-D4, for a total time of 20 minutes				
Segment A1 (Light and Auditory both sides pulse together) Repeat 116 times, followed by 0.5 sec gap	On 0.1277s	On 0.1277s	On 0.1277s	On 0.1277s
	Off 0.1277s	Off 0.1277s	Off 0.1277s	Off 0.1277s
Segment A2 (light and auditory on left side, alternating light and auditory on Right) Repeat 116 times, followed by 0.5 sec gap	On 0.1277s	Off 0.1277s	On 0.1277s	Off 0.1277s
	Off 0.1277s	On 0.1277s	Off 0.1277s	On 0.1277s
Segment A3 (both lights together, alternating with both auditory signals together) Repeat 115 times, followed by 0.5 sec gap	On 0.1277s	On 0.1277s	Off 0.1277s	Off 0.1277s
	Off 0.1277s	Off 0.1277s	On 0.1277s	On 0.1277s
Segment A4 (auditory left and light right together, alternating auditory right and light left together) Repeat 115 times, followed by 0.5 sec gap	On 0.1277s	Off 0.1277s	Off 0.1277s	On 0.1277s
	Off 0.1277s	On 0.1277s	On 0.1277s	Off 0.1277s
Segment D1 (Light and Auditory both sides pulse together) Repeat 221 times, followed by 0.5 sec gap	On 0.0667s	On 0.0667s	On 0.0667s	On 0.0667s
	Off 0.0667s	Off 0.0667s	Off 0.0667s	Off 0.0667s
Segment D2 (light and auditory on left side, alternating light and auditory on Right) Repeat 221 times, followed by 0.5 sec gap	On 0.0667s	Off 0.0667s	On 0.0667s	Off 0.0667s
	Off 0.0667s	On 0.0667s	Off 0.0667s	On 0.0667s
Segment D3 (both lights together, alternating with both auditory signals together) Repeat 221 times, followed by 0.5 sec gap	On 0.0667s	On 0.0667s	Off 0.0667s	Off 0.0667s
	Off 0.0667s	Off 0.0667s	On 0.0667s	On 0.0667s
Segment D4 (auditory left and light right together, alternating auditory right and light left together) Repeat 221 times, followed by 0.5 sec gap	On 0.0667s	Off 0.0667s	Off 0.0667s	On 0.0667s
	Off 0.0667s	On 0.0667s	On 0.0667s	Off 0.0667s

EXAMPLE 5

[0097] The following Table 4 lists experimental results for the use of the inventive methods. The table lists what was being tested or treated, details of the conditions, the number of subjects, and the results of the tests. In each case, the stimulation in Example 1 for treating non-sleep related problems and for inducing a short sleep, and the stimulation in Example 2 was used for all other treatments.

[0098] This is modified by changing brightness and volume, but also selected which of the four subsections, is working to produce the most stable rMSSD. And will adjust accordingly

[0099] Several of the treatments provided improvements in physical and/or mental performance, such as improving fine motor control and reaction times. This may be due to the device providing improved neuroplasticity in the days after treatment. Other treatments provided improvements in performing tasks and recovery from brain injury, such as injuries resulting from oxygen deprivation (strokes) and for those suffering from traumatic brain injury (TBI) or mild traumatic brain injury, and my provide improving balance, improving fine motor control. Other treatments provided relief to sufferers of PTSD by reducing the subject’s response to triggering stimuli.

TABLE 4

Treatment For	Details	No. of subjects	Results
Pain Management	Reduction of chronic nerve damage pain and improvement of sleep on self. Use of device for 3 months with 20 min/day of use of device	1	Eliminated chronic nerve damage pain for the time the device was used.
PTSD	Treating PTSD. Device use time of 5 hours.	3	Reduced flashbacks, nightmares and hypervigilance in all 3 subjects
Performance Enhancement	Marksmanship (rifles and pistols), endurance and speed driving (advanced surveillance, coordination and evasion). 6 hours training each subject.	20	Significant improvements in marksmanship in all participants and ease of concentration during speed driving, faster times on endurance trials for 19/20 subjects
Performance Enhancement	Fine motor skills on bomb disposal personnel 3 hours training with device	3	Improved performance of fine motor skills on bomb disposal VR simulation for all subjects

TABLE 4 (Continued)

<u>Treatment For</u>	<u>Details</u>	<u>No. of subj ects</u>	<u>Results</u>
Performance Enhancement	Fine motor skills of surgeons- 3 hours training each	3	Improved performance of fine motor skills on surgical procedures VR simulation for all subjects.
Performance Enhancement	Pistol use and marksmanship. 3 hours training	2	10% and 30% respectively increased speed in stripping and reassembling weapons. (average each of 5 tests, pre and post training) 6% average improvement in marksmanship scores - highly significant for such level of skill for all subjects
Performance Enhancement and PTSD	Performance by anti-terror and anti-drug squads of an elite firearms unit of a police force. 3 hours training each.	5	10% average improvement in scores. Total absence of any PTSD
Performance Enhancement	Marksmanship. 2 hours training	1	average grouping shrunk from 5 inches to 1 inch at 200 yds.
Brain State	Increasing alpha activity. 4 hours total training time per subject. Group 1 L&S stimulation and biofeedback. Group 2 - just L&S stimulation Group 3 just biofeedback, Group 4 control. Double blinded - those administering had no idea of what was predicted to happen	20	Results as predicted. Group 1 greatest change, followed by group 2, Group 3 least change of active groups. Group 4 no change.
Performance Enhancement	Marksmanship.	3 + 15	Significant improvement for all subjects.
Mental Performance Enhancement	Attention, learning and resistance to interrogation - 4 hours each person. Conduct after Capture course.	3	positive reports from all subjects
Performance Enhancement	Motion sickness for fixed wing aircraft pilots who have developed problems. 4 hours training per subject	4	Dramatic improvements in half of subjects. Small improvements in remaining half of subjects
PTSD	PTSD symptoms - test to remove neurological symptoms of flashbacks, nightmares and cold sweats	33	Successful in 31/33 subjects
Performance Enhancement	Driver performance using VR simulators for reaction speeds and performance under stress	2	Immediate increase in reaction speeds and improved performance for all subjects

TABLE 4 (Continued)

Treatment For	Details	No. of subjects	Results
Performance Enhancement	Professional soccer player performance. Trained for 4 hours. Battery of 21 tests	1	5-25% increase in speeds to complete tests
Inducing Sleep	Sleep patterning and circadian rhythm adjustment for crews setting endurance records. members each year. Also used for improving safety drills when parachuting	6	All subjects fell asleep using the device during training, including one subject that was ill with a virus and couldn't otherwise sleep.
Performance Enhancement	Race car driver performance. Ten days of training for 30 minutes per day.	1	Subject won his first Grand Prix of the season.
Performance Enhancement	Soccer player kicking performance. 5 days of 1 hour each day	1	Subject went from 5th ranked to highest ranked
Stroke Recovery	Use on 6 year post stroke subjects. four hours training.	10	Observable balance improvement in 7/10 subjects. 3 subjects had had dramatic improvements in their sleep.
Epilepsy Seizure Reduction	Effect on seizures of photosensitive epileptics. 4 hours training	3	One subject was found to not be epileptic. The other two subjects had a reduction in both severity and frequency of seizures, for at least a period of at least one month.
Concussion Recovery	Effect on concussions	18	All subjects appeared to have recovery happen at very fast speed.
Performance Enhancement	Effect on musical ability of a jazz musician.	1	Greatly improved performance speed
PTSD	PTSD. Treatment protocol lasting 3 sessions of 2 hours each	22	19 individuals saw a cessation of major symptoms - flashbacks, nightmares, cold sweats and hypervigilance. the remaining 3 appeared to be calmer after treatment, but did not stop the major neurological symptoms
Sleep	Insomnia	1	Goes to sleep 4 times in 45 mins
Pain Management	Chronic Regional Pain Syndrome	1	Subject had constant pain on touching arms with no relief in 3 years Subject saw immediate pain relief on first use of the device. Continued use over the following weeks results in periods of time without pain grow up to four hours following each use. Averaging at two hours.

TABLE 4 (Continued)

Treatment For	Details	No. of subj ects	Results
Pain Management and Sleep	Chronic pain	1	After six months of use, the subject continues getting 30% more sleep, and a significant reduction in pain. Device continues to be used 3-4 times a week for 20 min.

[00100] While preferred embodiments of the present invention have been shown and described herein, it will be obvious to those skilled in the art that such embodiments are provided by way of example only. Numerous variations, changes, and substitutions will now occur to those skilled in the art without departing from the invention. It should be understood that various alternatives to the embodiments of the invention described herein may be employed in practicing the invention. It is intended that the following claims define the scope of the invention and that methods and structures within the scope of these claims and their equivalents be covered thereby. The invention includes all of the different combinations embodied herein.

[00101] It is to be understood that the invention includes all of the different combinations embodied herein. Throughout this specification, the term “comprising” shall be synonymous with “including,” “containing,” or “characterized by,” is inclusive or open-ended and does not exclude additional, unrecited elements or method steps. “Comprising” is a term of art which means that the named elements are essential, but other elements may be added and still form a construct within the scope of the statement. “Comprising” leaves open for the inclusion of unspecified ingredients even in major amounts.

CLAIMS

WHAT IS CLAIMED IS:

1. A method of providing stimulation to a user for a treatment time, the method comprising:
 - providing a headset to be worn by the user, where the headset includes four stimuli sources including a left light source activated to provide visual stimuli to the left eye of the user, a right light source activated to provide visual stimuli to the right eye of the user, a left vibration source activated to provide auditory stimuli to the left side of a head of the user, and a right vibration source activated to provide auditory stimuli to the right side of the head of the user;
 - obtaining a measurement of the user using a sensor;
 - determining a state of the user from the obtained measurement;
 - activating each of said stimuli sources between a high stimuli and a low stimuli at a stimulation frequency for a period of time including, where at least part of said activating includes activating at least two of said four stimuli sources out of phase with the activating of at least two other of the four stimuli sources; and
 - modifying said activating according to said determined state of the user.
2. The method of claim 1, where said activating further includes synchronously activating said four stimuli sources for a period of time.
3. The method of claim 1, where said activating includes one or more of
 - synchronously activating said left light source and said left vibration source out of phase with said right light source and said right vibration source for a period of time,
 - synchronously activating said left light source and said right light source out of phase with said left vibration source and said right vibration source for a period of time,
 - or
 - synchronously activating said left light source and said right vibration source out of phase with said left vibration source and said right light source for a period of time.
4. The method of claim 2, where said activating includes alternating between
 - synchronously activating said four stimuli sources for a period of time,
 - synchronously activating said left light source and said left vibration source out of phase with said right light source and said right vibration source for a period of time,
 - synchronously activating said left light source and said right light source out of phase with said left vibration source and said right vibration source for a period of time,
 - and
 - synchronously activating said left light source and said right vibration source out of phase with said left vibration source and said right light source for a period of time.

5. The method of any one of the above claims, where modifying includes modifying said stimulation frequency of said four stimuli sources.
6. The method of any one of claims 1-4, where modifying includes modifying the temporal length of said activating of said four stimuli sources.
7. The method of any one of claims 1-4, where modifying includes modifying a high stimuli level of at least one stimuli source of said four stimuli sources.
8. The method of any one of claims 1-4, where modifying includes modifying the temporal length of said activating of said four stimuli sources.
9. The method of any one of claims 1-4, where said sensor is a heart rate sensor, a heart rate variability (HRV) sensor, a temperature sensor, a motion sensor, a galvanic skin response sensor, an accelerometer, an EEG or an EMG.
10. The method of claim 9, where said determined state of the user is a state of sleep or the level or change in level of relaxation or arousal.
11. The method of claim 10, where said modifying includes modifying a high stimuli level of said left vibration source and said right vibration source.
12. The method of claim 10, and where said modifying includes modifying a high stimuli level of said left light source and said right light source.
13. The method of claim 10, where said modifying said activating according to said determined state of the user includes modifying the temporal length of said activating of said four stimuli sources.
14. The method of claim 10, where said activating includes activating each of said stimuli sources at a first stimulation frequency for a first period of time and activating each of said stimuli sources at a second stimulation frequency for a second period of time, where said first stimulation frequency is in a first frequency range of 1.0 and 3.0 Hz, 3.0 to 7.0 Hz, 7.0 to 12 Hz, 12 to 38 Hz or 38 to 42 Hz, and where said second stimulation frequency is in a second frequency range of 1.0 and 3.0 Hz, 3.0 to 7.0 Hz, 7.0 to 12 Hz, 12 to 38 Hz or 38 to 42 Hz, and where said first stimulation frequency is in a different frequency range than said second stimulation frequency range.
15. The method of claim 10, where said determined state of the user is a state of sleep determined to be REM sleep, said where said modifying said activating according to said determined state of the user includes reducing the high stimuli level at least one of said four stimuli sources.
16. The method of claim 15, where said sensor is a temperature sensor, an EMG sensor, a heart rate sensor, an HRV sensor, and EEG sensor, or an accelerometer.

17. The method of claim 15, where said sensor is two or more sensors including a first sensor including one of an HRV sensor or a heart rate sensor and one or more sensors including a temperature sensor, an EMG sensor, an EEG sensor, or an accelerometer.
18. The method of claim 15, where said modifying said activating according to said determined state of the user includes reducing the stimuli level of each of four stimuli sources until the stimuli sources are turned off.
19. The method of claim 18, where said modifying said activating according to said determined state of the user includes reducing the stimuli level of each of four stimuli sources 20% every 20 seconds.
20. The method of claim 10, where said sensor is a heart rate sensor or a heart rate variability (HRV) sensor, where said determined state of the user is a state of relaxation or sleep state indicated by the HRV.
21. The method of claim 20, where said determined state of the user is a state of relaxation or sleep state indicated by an increase in HRV, and where said modifying said activating according to said determined state of the user includes reducing the stimuli level of each of four stimuli sources until the stimuli sources are turned off and/or shortening the treatment time.
22. The method of claim 20, where said determined state of the user is a less relaxed state or stressed state indicated by a decrease in HRV, and where said modifying said activating according to said determined state of the user includes increasing the stimuli level of each of four stimuli sources and/or increasing the treatment time.
23. The method of claim 9, where said determined state of the user is a hemispheric imbalance of brainwaves, where said sensor is an EEG sensor, where said state is the hemispheric imbalance of brainwaves includes a more active hemisphere of the brain, and where said modifying said activating according to said determined state of the user includes increasing the high stimuli level stimuli sources to the less active hemisphere of the brain.
24. A device to provide stimulation to a user for a treatment time, the device comprising:
 - a headset to be worn by the user, where the headset includes four stimuli sources including a left light source activated to provide visual stimuli to the left eye of the user, a right light source activated to provide visual stimuli to the right eye of the user, a left vibration source activated to provide auditory stimuli to the left side of a head of the user, and a right vibration source activated to provide auditory stimuli to the right side of the head of the user;
 - a sensor in to obtain a measurement of the user; and
 - a processor programmed to
 - accept said measurement and determine a state of the user from the

measurement,

determine a state of the user from the obtained measurement;

activate each of said stimuli sources between a high stimuli and a low stimuli at a stimulation frequency for a period of time including, where at least part of said activating includes activating at least two of said four stimuli sources out of phase with the activating of at least two other of the four stimuli sources, and

modify the activation of each of said stimuli sources according to said state of the user.

25. The device of claim 24, where said sensor includes one or more of a heart rate sensor, a heart rate variability (HRV) sensor, a temperature sensor, a motion sensor, a galvanic skin response sensor, an accelerometer, an EEG or an EMG.
26. The device of any one of claims 24 or 25, where said processor is programmed to further activate said four stimuli sources synchronously for a period of time.
27. The device of claim 26, where said processor is programmed to alternate between
synchronously activating said four stimuli sources for a period of time,
synchronously activating said left light source and said left vibration source out of phase with said right light source and said right vibration source for a period of time,
synchronously activating said left light source and said right light source out of phase with said left vibration source and said right vibration source for a period of time,
and
synchronously activating said left light source and said right vibration source out of phase with said left vibration source and said right light source for a period of time.
28. The device of any one of claims 24 or 25, where state of the user is a state of sleep or the level or change in level of relaxation or arousal determined from a temperature sensor, a heart rate or HRV sensor.
29. The device of any one of claims 24 or 25, where said processor is programmed to modify the activation of each of said stimuli sources according to said state of the user includes one or more of changing the high stimuli level at least one of said four stimuli sources, the stimulation frequency, or the treatment time.
30. The device of any one of claims 24 or 25, where state of the user is a state of hemispheric imbalance of brainwaves, where said sensor is an EEG sensor, where processor is programmed to increase the high stimuli level stimuli sources to the less active hemisphere of the brain.

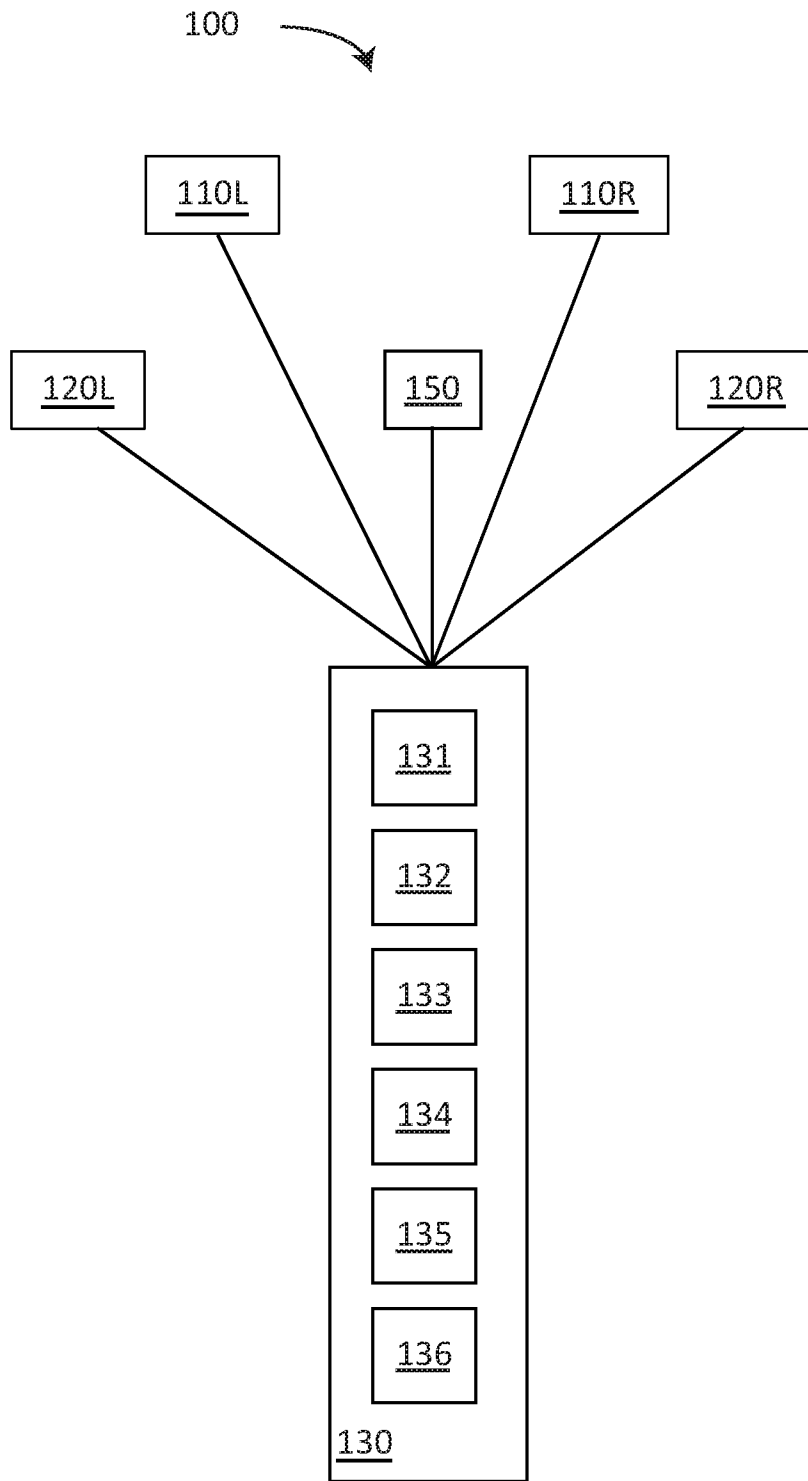

FIG. 1A

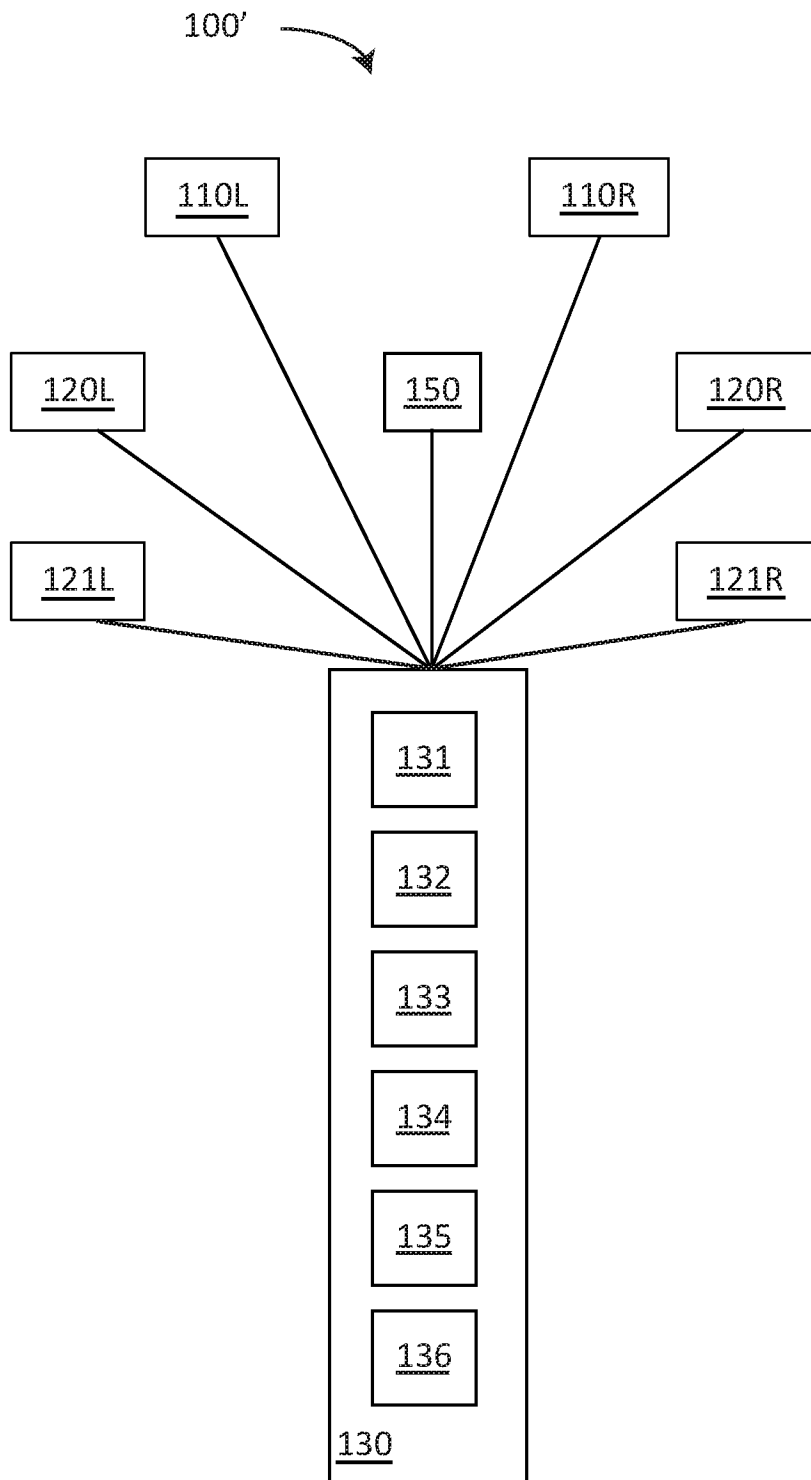

FIG. 1A

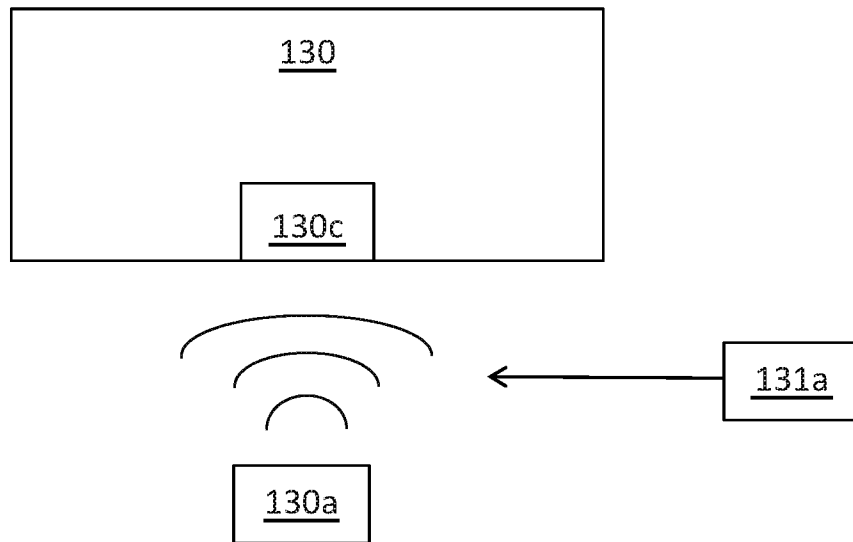

FIG. 2A

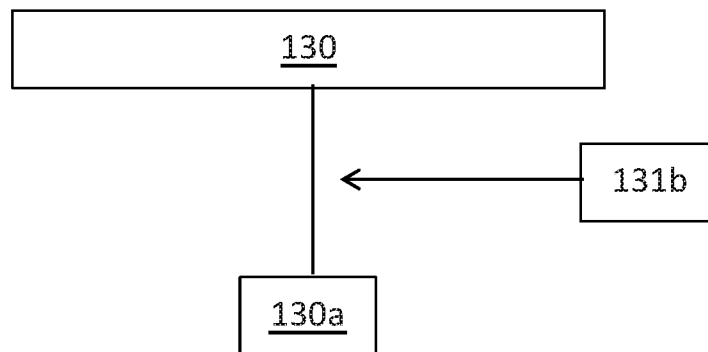

FIG. 2B

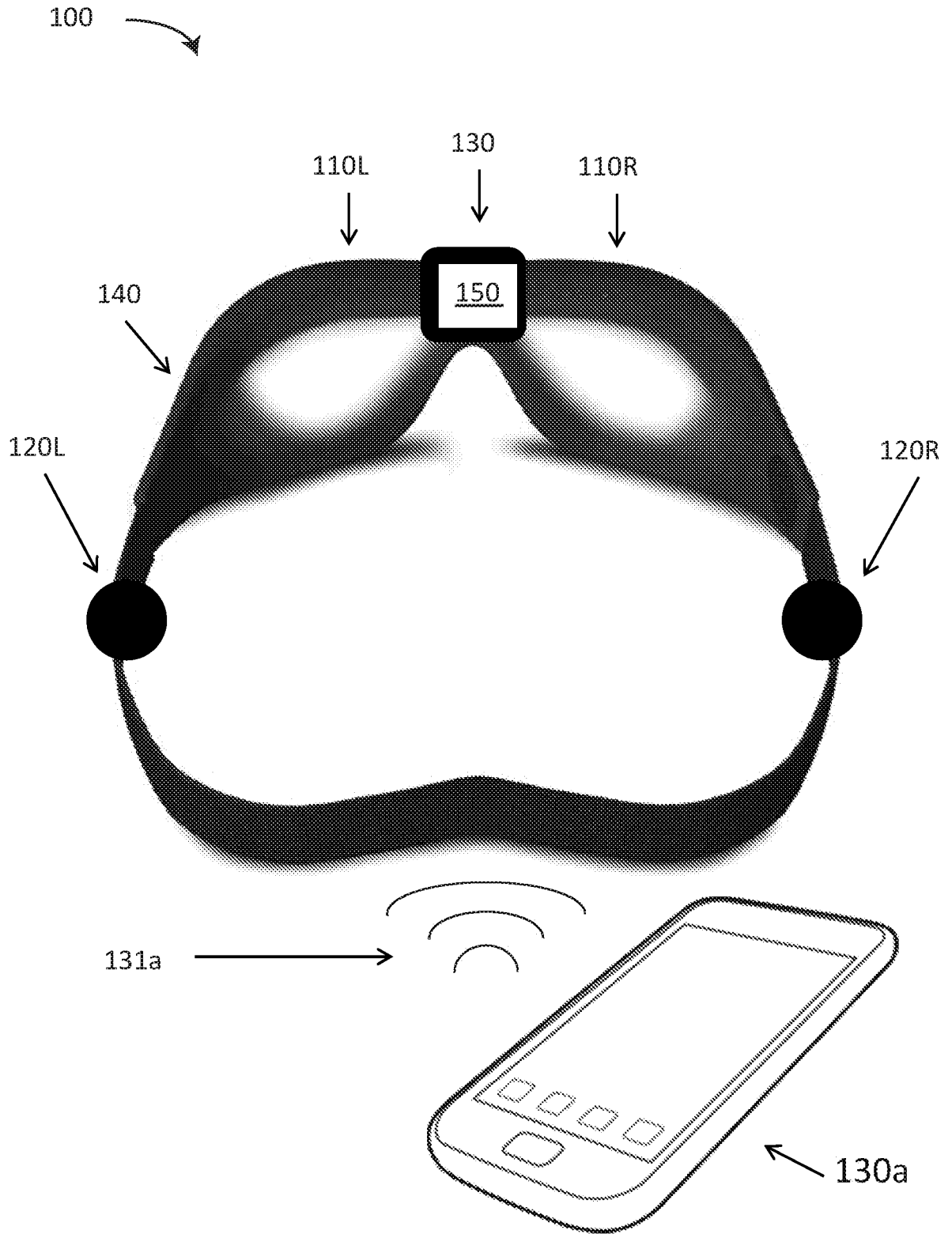

FIG. 3A

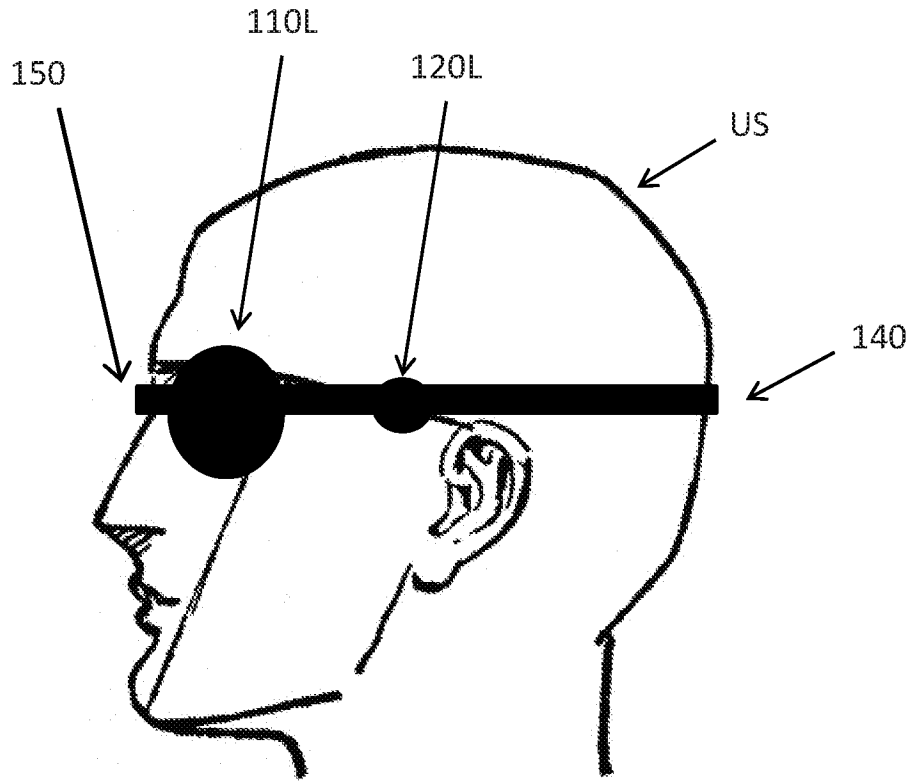

FIG. 3B

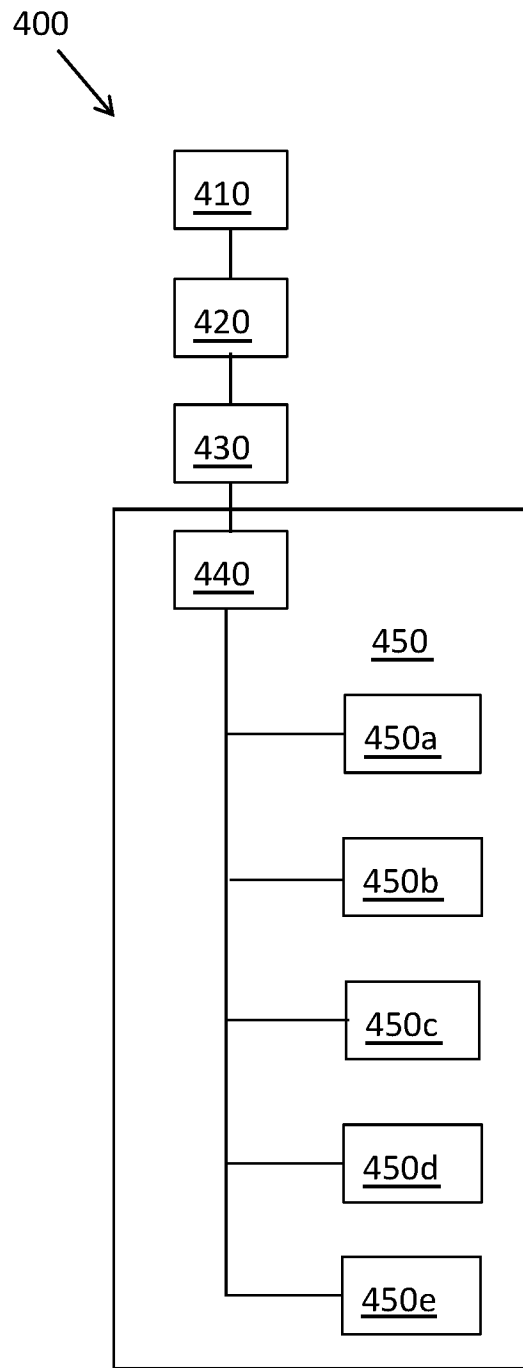

FIG. 4

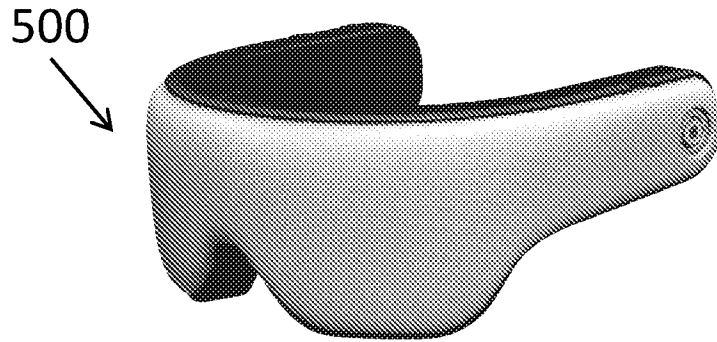

FIG. 5

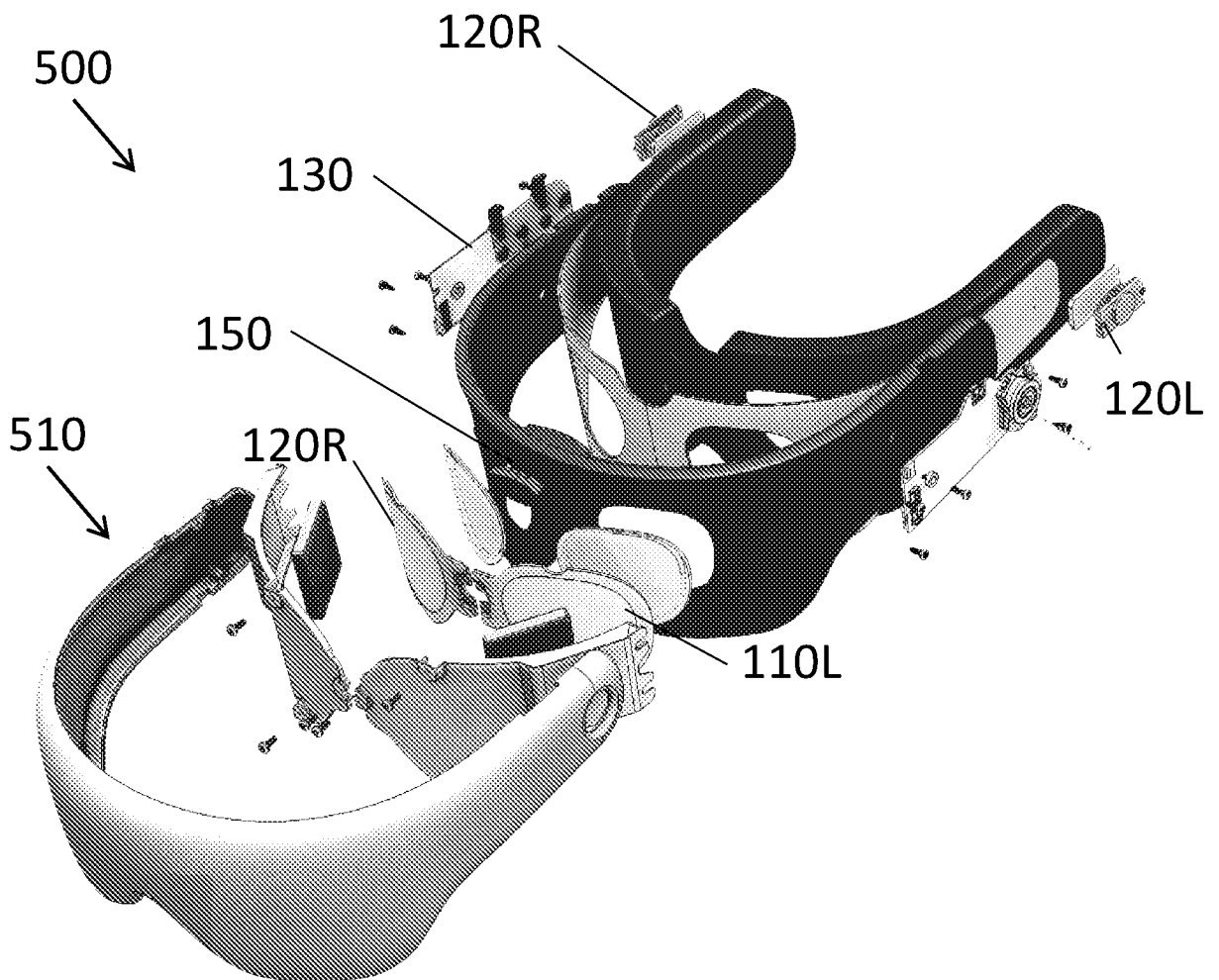

FIG. 6

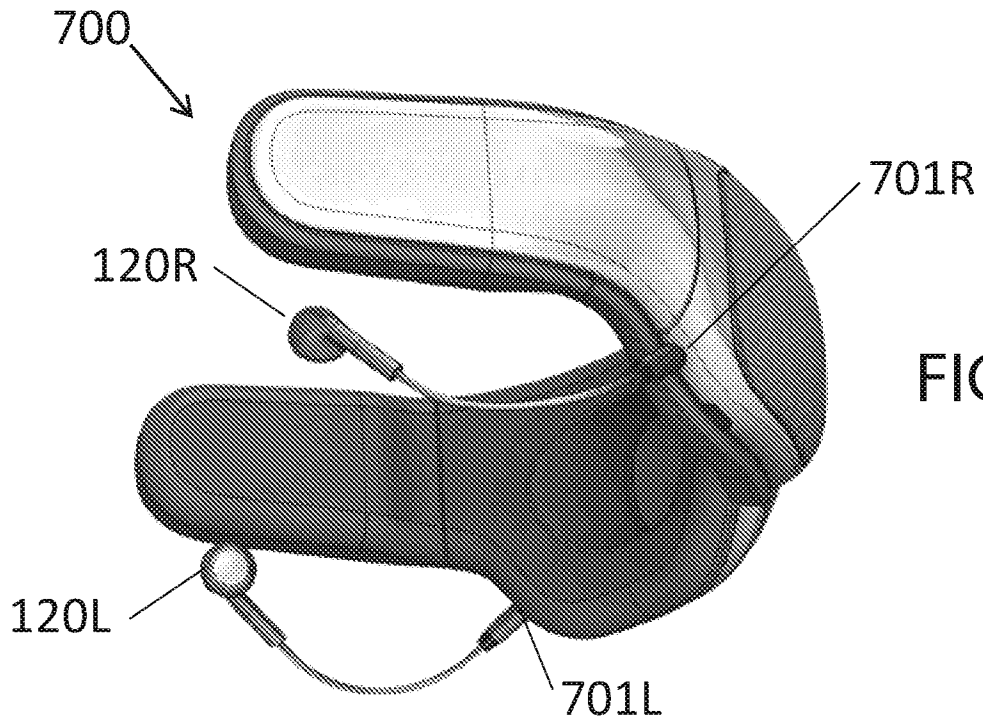

FIG. 7A

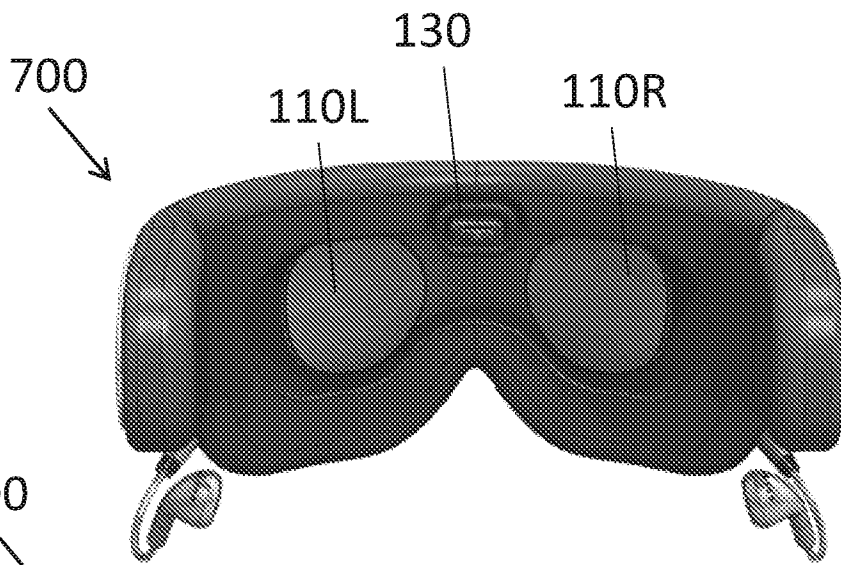

FIG. 7B

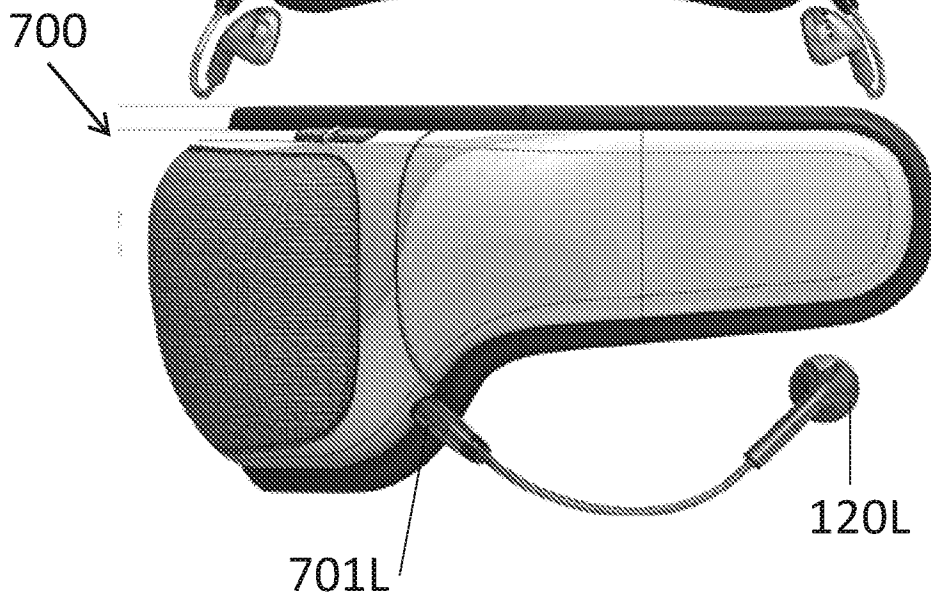

FIG. 7C

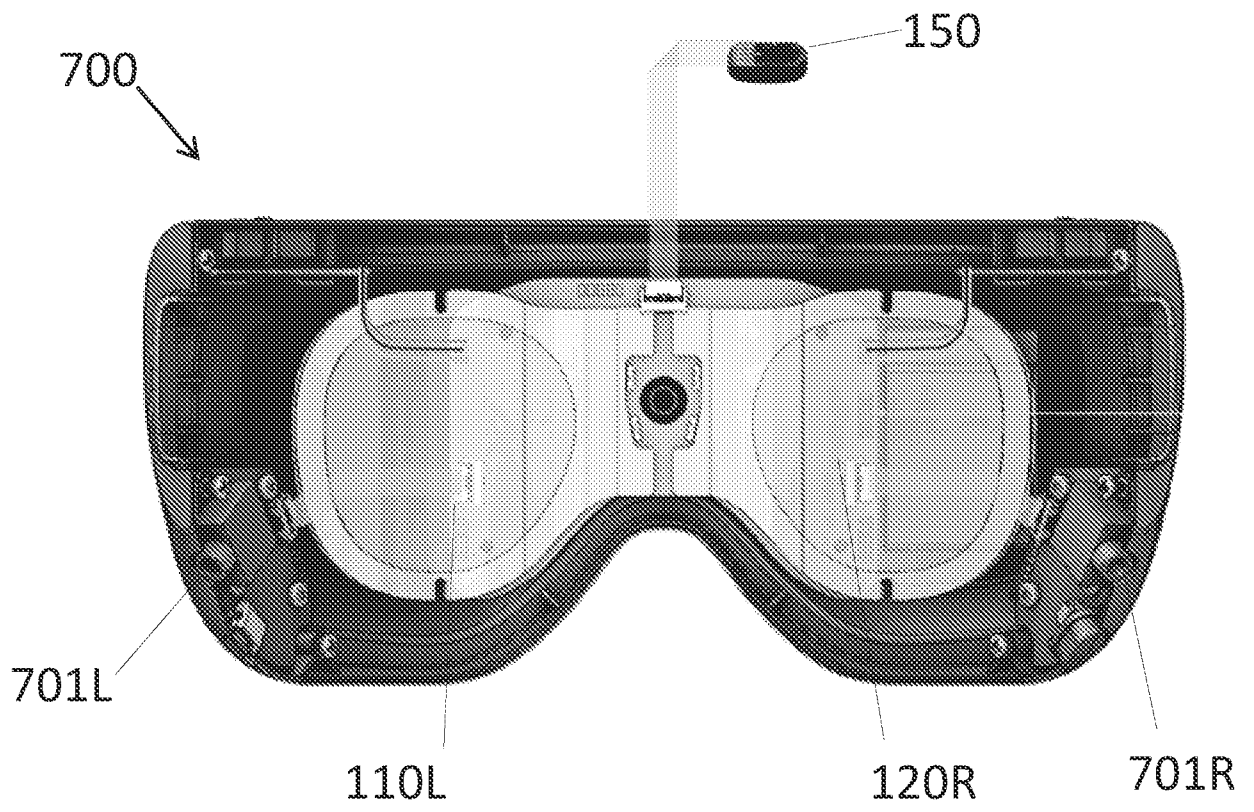

FIG. 8

INTERNATIONAL SEARCH REPORT

International application No.

PCT/US2018/020547

A. CLASSIFICATION OF SUBJECT MATTER

IPC(8) - A61B 5/00; A61B 5/02; A61M 21/00; A61M 21/02; G02B 27/01; G06F 3/01 (2018.01)

CPC - A61B 5/024; A61B 5/6803; A61M 21/00; A61M 2021/0022; A61M 2021/0027; A61M 21/02 (2018.02)

According to International Patent Classification (IPC) or to both national classification and IPC

B. FIELDS SEARCHED

Minimum documentation searched (classification system followed by classification symbols)

See Search History document

Documentation searched other than minimum documentation to the extent that such documents are included in the fields searched

USPC - 600/27; 600/301; 600/544; 600/545; 607/45 (keyword delimited)

Electronic data base consulted during the international search (name of data base and, where practicable, search terms used)

See Search History document

C. DOCUMENTS CONSIDERED TO BE RELEVANT

Category*	Citation of document, with indication, where appropriate, of the relevant passages	Relevant to claim No.
Y	US 2014/0336473 A1 (GRECO) 13 November 2014 (13.11.2014) entire document	1-3, 5-14, 20, 24-26, 28, 29
Y	US 5,343,261 A (WILSON) 30 August 1994 (30.08.1994) entire document	1-3, 5-14, 20, 24-26, 28, 29
Y	US 2012/0211013 A1 (OTIS) 23 August 2012 (23.08.2012) entire document	14
A	US 8,838,247 B2 (EVOKE NEUROSCIENCE, INC.) 16 September 2014 (16.09.2014) entire document	1-30
A	US 2013/0267759 A1 (NEWPORT BRAIN RESEARCH LABORATORY INC.) 10 October 2013 (10.10.2013) entire document	1-30

 Further documents are listed in the continuation of Box C.
 See patent family annex.

* Special categories of cited documents:

"A" document defining the general state of the art which is not considered to be of particular relevance

"E" earlier application or patent but published on or after the international filing date

"L" document which may throw doubts on priority claim(s) or which is cited to establish the publication date of another citation or other special reason (as specified)

"O" document referring to an oral disclosure, use, exhibition or other means

"P" document published prior to the international filing date but later than the priority date claimed

"T" later document published after the international filing date or priority date and not in conflict with the application but cited to understand the principle or theory underlying the invention

"X" document of particular relevance; the claimed invention cannot be considered novel or cannot be considered to involve an inventive step when the document is taken alone

"Y" document of particular relevance; the claimed invention cannot be considered to involve an inventive step when the document is combined with one or more other such documents, such combination being obvious to a person skilled in the art

"&" document member of the same patent family

Date of the actual completion of the international search

13 April 2018

Date of mailing of the international search report

07 MAY 2018

Name and mailing address of the ISA/US

Mail Stop PCT, Attn: ISA/US, Commissioner for Patents

P.O. Box 1450, Alexandria, VA 22313-1450

Facsimile No. 571-273-8300

Authorized officer

Blaine R. Copenheaver

PCT Helpdesk: 571-272-4300

PCT OSP: 571-272-7774