



(12) **EUROPEAN PATENT APPLICATION**

(43) Date of publication:
23.04.2003 Bulletin 2003/17

(51) Int Cl.7: **F24D 3/10, F24H 9/12**

(21) Application number: **02016826.6**

(22) Date of filing: **29.07.2002**

(84) Designated Contracting States:
**AT BE BG CH CY CZ DE DK EE ES FI FR GB GR
IE IT LI LU MC NL PT SE SK TR**
Designated Extension States:
AL LT LV MK RO SI

(72) Inventors:
• **Zaia, Franco**
31016 Cordignano (Prov. of Treviso) (IT)
• **Agostinetti, Daniele**
31010 Farra di Soligo (Prov. of Treviso) (IT)

(30) Priority: **15.10.2001 SM 200100020**

(74) Representative: **Modiano, Guido, Dr.-Ing. et al**
Modiano & Associati SpA
Via Meravigli, 16
20123 Milano (IT)

(71) Applicant: **R.D.Z. S.p.A.**
33077 Sacile (Pordenone) (IT)

(54) **Distribution Module for Heating or Cooling Circuit**

(57) A distribution module (1), particularly for distributing heating or cooling water, comprising a containment compartment (2) for a plurality of ducts (3a,3b,

6,10,16,20,22,23) suitable to connect at least one first high-temperature circuit and/or one second low-temperature circuit, which are mutually connected by an adjustment valve (7) and a calibration valve (8).

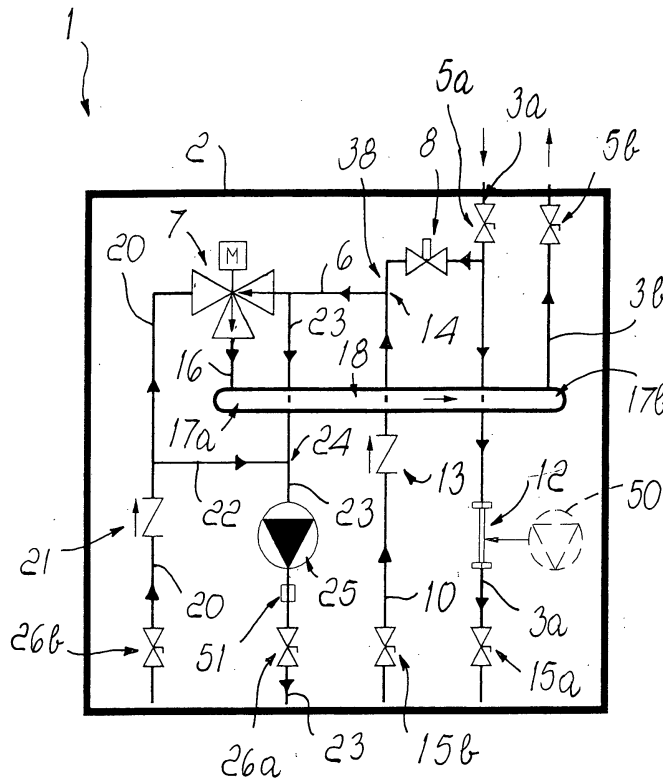

Fig. 1

Description

[0001] The present invention relates to a distribution module particularly suitable to be used to distribute water for heating or cooling.

[0002] Currently, a building or a portion of a building are usually heated or cooled by means of water, brought respectively to a high or low temperature by passing through a heat source, such as a boiler, or a cooling unit.

[0003] Such water is circulated in a distribution circuit toward one or more heat exchangers of the water-air type, such as radiators, radiating panels or a fan coil system.

[0004] Currently, water distribution to heat exchangers is usually controlled by means of electronic devices suitable to affect the adjustment of the boiler and the water circuits on the basis of measurements performed for example by room thermostats.

[0005] Accordingly, in modern building technology there is the drawback of providing technical sections reserved for placing the electronic devices and most of all the adjustment and control elements operated by such devices (for example pumps, calibration valves, mixing and/or distribution valves).

[0006] The main drawback is particularly that it is necessary to determine the technical section in each instance, according to each specific building structure, since every building has a specific heat demand, preset areas at different temperatures (for example, a home usually requires a daytime area, a night area and optionally a guest area) and other specific characteristics that require dedicated technical choices.

[0007] Accordingly, the installer of the system must have great experience and availability of time and resources, which affects the overall cost of the system.

[0008] In any case, the important problem of not having uniform technical solutions between two separate heating systems and of not having high efficiency or assurance of results between the systems remains evident; this is worsened by the fact that the presence of specialist workers of various kinds is often required, since the installer of the hydraulic components often does not have a specialization that is sufficient to install the electrical section as well.

[0009] As a consequence of all the above-mentioned problems and drawbacks, sometimes heating systems are installed which operate incorrectly, with high consumption and a high risk of abnormal operation and breakdowns, with obvious dissatisfaction of the user.

[0010] The situation is even worse when a mixed thermal system, providing both high temperatures by means of radiators and low temperatures by means of floor- or wall-mounted radiating panels, is required.

[0011] The aim of the present invention is to solve the noted problems, eliminating the drawbacks of the cited prior art and thus providing an invention that allows to install simply and rapidly a heating system in a building or in a portion of a building.

[0012] Within this aim, a further object is to provide an invention that allows even non-specialized personnel to perform the installation, often requiring a single installer for the entire system.

5 **[0013]** Another object is to provide an invention that allows unified and simultaneous management of a plurality of high-temperature circuits (for example radiators) together with a plurality of low-temperature circuits (such as floor- or wall-mounted radiating panels), and allows to use the same system for summer cooling.

10 **[0014]** Another object is to minimize not only the installation costs of the system but also its management costs.

15 **[0015]** Another object of the invention is to optimize temperature control, ensuring that comfortable conditions for the user are maintained automatically.

[0016] Another object is to have an installation that is compact, reliable over time and aesthetically pleasant.

[0017] Another object is to provide an invention that is structurally simple and has low manufacturing costs.

20 **[0018]** This aim and these and other objects that will become better apparent hereinafter are achieved by a distribution module, particularly for distributing heating or cooling water, characterized in that it comprises a containment compartment for a plurality of ducts suitable to constitute at least one first high-temperature circuit and/or one second low-temperature circuit, which are mutually connected by means of an adjustment valve and a calibration valve, and a panel for the electrical wiring of said valves.

25 **[0019]** Further characteristics and advantages of the present invention will become apparent from the following detailed description of a particular embodiment thereof, illustrated only by way of non-limitative example in the accompanying drawings, wherein:

Figure 1 is a schematic view of the circuit according to the invention;

Figure 2 is a schematic view of the circuit of the invention applied to a heating system provided with one high-temperature circuit and one low-temperature circuit;

Figure 3 is a schematic view of the circuit of the invention applied to a heating system provided with two high-temperature circuits and two low-temperature circuits;

Figure 4 is a schematic view of the circuit of the invention applied to a heating system provided with three high-temperature circuits and three low-temperature circuits;

Figure 5 is a schematic view of the circuit of the invention applied to a heating and cooling system provided with one high-temperature circuit and one low-temperature circuit;

Figure 6 is a schematic view of the circuit of the invention according to an operating mode for feeding only the high-temperature circuit;

Figure 7 is a schematic view of the circuit of the in-

vention according to an operating mode for feeding only the low-temperature circuit;

Figure 8 is a schematic view of the circuit of the invention according to an operating mode for feeding both the high-temperature circuit and the low-temperature circuit.

[0020] With reference to Figure 1, the reference numeral 1 designates a distribution module, particularly suitable for distributing heating or cooling water in a building or in a portion thereof.

[0021] The distribution module 1 comprises a compartment, designated by the reference numeral 2, for containing a plurality of ducts suitable to allow to adjust the flow-rate and temperature of the water to be sent to heating bodies, such as for example radiators, radiating panels and/or fan coils.

[0022] A cabinet or enclosure, either recessed or arranged against a wall, is used for example as a compartment 2.

[0023] The compartment 2 is provided with a first duct 3a, suitable for the inflow of hot water arriving from a heat source, such as for example a boiler, designated by the reference numeral 4 in Figures 2 to 5.

[0024] Proximate to the first duct 3a there is advantageously a second duct, designated by the reference numeral 3b, which is designed to return to the boiler 4 an identical flow-rate of water, cooled beforehand in said heating bodies.

[0025] Inside compartment 2, the first and second ducts 3a and 3b are conveniently controlled by a first flow control valve 5a and a second flow control valve 5b, for example of the ball type.

[0026] Downstream of the first flow control valve 5a, the first duct is affected by a third duct, designated by the reference numeral 6, for connection to an adjustment or mixing valve, such as a three-way valve, designated by the reference numeral 7.

[0027] A calibration valve 8, such as for example a micrometric lockshield valve, is arranged along said third duct 6 and is suitable to adjust the flow-rate of hot water circulating in a first high-temperature circuit, designated by the reference numeral 9 in Figure 6, for supplying heating bodies, such as radiators, which operate in optimum conditions with water at a temperature of 70 to 80°C.

[0028] The water is returned from the radiators by means of a fourth duct, designated by the reference numeral 10 in Figure 6, which is connected to the third duct 6 downstream of the calibration valve or micrometric lockshield valve 8.

[0029] Circulation of the water in the first circuit is usually ensured by the first pump, designated by the reference numeral 11 in Figures 2 to 5, which is integrated in the boiler 4.

[0030] If a very high flow-rate, higher than the one that can be produced by the first pump 11, is required in the first circuit, it is possible to replace a portion or segment,

designated by the reference numeral 12, of the first duct 3a with a second pump 50.

[0031] In order to ensure clockwise circulation in the first circuit 9, a first one-way valve 13 of Figure 1 is inserted along the fourth duct 10, specifically upstream of a first tee, designated by the reference numeral 14, where the fourth duct 10 and the third duct 6 merge.

[0032] Moreover, a third flow control valve 15a and a fourth flow control valve 15b are also preferably employed and are located respectively proximate to the outlet of the first duct 3a and the inlet of the fourth duct 10.

[0033] As the micrometric lockshield valve 8 opens, the flow-rate of water diverted toward the mixing valve 7 increases; when the lockshield valve is completely open, the flow-rate along the first duct 3a is approximately nil, since the first circuit has much higher load losses than those generated by the first lockshield valve 8.

[0034] The water arriving at the mixing valve 7 is diverted, by means of a fifth duct 16, into a first end 17a of a first manifold, designated by the reference numeral 18, which is arranged approximately horizontally.

[0035] The second duct 3b for the return of the water toward the boiler 4 is connected to a second end 17b of the manifold 18.

[0036] Figure 6 clearly shows that the flow-rate through the mixing valve 7 and the manifold 18 is equal to the entire flow-rate processed by the first boiler pump 11, since the flow-rate diverted to the radiators merges again in the third duct 6, after partial cooling, at the first tee 14.

[0037] Figure 7 illustrates the operation of the invention exclusively for low-temperature heating by circulating water in a second low-temperature circuit, designated by the reference numeral 19.

[0038] Such second circuit 19 comprises heating bodies which are suitable to operate in optimum conditions with water at a temperature between 35 and 50 °C, such as for example radiating panels.

[0039] In order to achieve this use, the lockshield valve 8 is placed in the fully open position; likewise, the mixing valve 7 is adjusted so as to allow an at least partial inflow of water from a sixth duct, designated by the reference numeral 20, for return from said radiating panels.

[0040] A second one-way valve 21 is conveniently arranged along the sixth duct 20 and is suitable to allow circulation of the water in the second circuit 19 only clockwise.

[0041] A seventh duct, designated by the reference numeral 22 and termed bypass duct, is connected downstream of the second one-way valve 21 and is suitable to make a fraction of the water flow-rate merge toward an eighth duct 23 for supplying the radiating panels.

[0042] The eighth duct 23 connects the third duct 6, downstream of the first tee 14, to the second tee, des-

ignated by the reference numeral 24, with the bypass duct 22, then to a third pump 25, and from there to the outlet toward the radiating panels.

[0043] The third pump circulates water between the sixth, seventh and eighth ducts 20, 22 and 23 and the radiating panels.

[0044] The inflow of water from the third duct 6 into the eighth duct 23 is regulated by the mixing valve 7; the smaller the flow-rate entering the mixing valve 7 through the third duct 6, the higher the flow-rate circulating in the sixth and eighth ducts 20 and 23.

[0045] The flow-rate along the bypass duct 22 accordingly adapts to the flow-rate that arrives from the eighth duct 23, in order to keep the flow-rate in the second circuit 19 approximately constant.

[0046] It can be noted that the mixing valve 7, by adjusting the flows of hot water that arrives from the boiler 4 (by means of the third duct 6) and of cooled water that arrives from the radiating panels, determines the temperature of the water that leaves the eighth duct 23 and thus also determines the amount of heat transferred to the room to be heated.

[0047] Conveniently, a fifth flow control valve 26a and a sixth flow control valve 26b are provided at said outlet of the eighth duct 23, and likewise at the inlet of the sixth duct 20.

[0048] Figure 8 illustrates a module 1 that distributes and controls water in the first high-temperature circuit 9 and simultaneously in the second low-temperature circuit 19.

[0049] The water that arrives from the fourth duct 10, partially cooled during its passage through the radiators until it reaches a temperature that is approximately 5 + 10 °C lower than the boiler temperature, enters in the third duct 6 and from there, depending on the mixing valve 7, partially enters the eighth duct 23 and partially enters the manifold 18 to return to the boiler 4.

[0050] The fraction of water that enters the eighth duct 23 increases as the demand for heat in the room heated by the radiating panels increases; likewise, an equivalent amount of water flows from the sixth duct 20 into the mixing valve 7 and from there to the manifold 18 and to the boiler.

[0051] When the demand for heating decreases, the adjustment of the mixing valve 7 varies, so as to have a low flow-rate of water arriving from the sixth duct 20 and likewise a low flow-rate of water entering the eighth duct 23.

[0052] A first application of the module 1 is shown in Figure 2; in addition to the boiler 4, which is provided with the first built-in pump 11, the figure shows a first area that is heated by means of radiators (only one radiator, designated by the reference numeral 27, has been shown for the sake of simplicity), and a second area that is heated by means of radiating panels, one of which is designated by the reference numeral 28.

[0053] The first and second areas can be mutually distinct or can be the same if differentiated heating is re-

quired or if winter heating by means of radiators 27 and summer cooling by means of radiating panels 28 is required.

[0054] Usually, in any case, this first application of the invention is suitable for use in homes, for example by using radiators for heating the bathrooms and radiating panels to heat and cool the other rooms; this solution also has the advantage of not requiring installation of the second pump 50, since the flow-rate required by the first circuit 9 is very low.

[0055] Temperature control in the second areas is provided for example by means of a room thermostat, designated by the reference letters TA and by the reference numeral 29, which is connected to an electrical panel 30 suitable to provide the electrical wiring of the mixing valve 7 and of the feed pumps.

[0056] The electrical panel 30 is advantageously integrated in the module 1, so that the connections, not shown in the figures, to the valves and pumps, integrated in the module 1, are provided directly during production and are not left to the installer.

[0057] Figure 3 illustrates a second application of the module 1, which is more complicated because it comprises two sets of radiating panels, designated by the reference numerals 28a and 28b, and two sets of radiators 27a and 27b.

[0058] In this manner it is possible to heat four independent areas, such as for example a daytime area, a night area, and two bathrooms.

[0059] Temperature control of each area is advantageously performed by means of room thermostats, designated by the reference numerals 29a, 29b, 29c and 29d in Figure 3, which are all connected to the electrical panel 30.

[0060] Each one of the sets of radiators 27a and 27b and of radiating panels 28a and 28b is fed by means of zone valves, such as valves of the type commonly known as "on/off" (i.e., "fully-open or fully closed"), conveniently connected to the electrical panel 30 and controlled thereby.

[0061] The example shown in Figure 3 illustrates a first pair of zone valves 31a and 31b for feeding the radiating panels and a second pair of zone valves 32a and 32b for feeding the radiators.

[0062] The first pair of zone valves 31a and 31b adjusts the feeding of water from the eighth duct 23 to the radiating panels 28a and 28b; likewise, the second pair of zone valves 31c and 31d connects the first duct 3a to the radiators 27a and 27b.

[0063] Figure 4 illustrates a third application of the invention, which is suitable to feed three sets of radiating panels 28 and three sets of radiators 29, which are respectively controlled by room thermostats generally designated by the reference numeral 29.

[0064] Feed control is performed, in this particular application which is illustrated only by way of example, by means of separate zone valves, designated by the reference numeral 32, which are installed proximate to the

radiating panels 28 and are appropriately connected electrically to the electrical panel 30.

[0065] In all these applications, the mixing valve 7 can be controlled in various manners.

[0066] A first manner consists in using a first capillary probe, designated by the reference numeral 51 in Figure 1, which is suitable to read the temperature of the water at the delivery of the third pump 25 and to send the corresponding signal to a thermostatic actuator; such actuator directly controls the mixing valve 7 according to the reference temperature preset by the user.

[0067] A second manner of controlling the mixing valve 7 uses an electric servo control operated by an electronic control unit, designated by the reference numeral 52 in Figure 5 and connected to the electrical panel 30.

[0068] The electronic control unit 52 processes the signals sent by a second temperature probe 53, located at the delivery of the third pump 25, and by a third probe 54 for detecting the external temperature.

[0069] A variation of the module 1, shown in Figure 5, comprises preinstalled ducts suitable to allow the interconnection of a water cooling unit, designated by the reference numeral 33, which is provided with a built-in fourth feed pump 34.

[0070] The ducts are constituted for example by a second manifold 35, arranged along the first duct 3a downstream of the first flow control valve 5a, which is fed by a ninth duct, designated by the reference numeral 36, which is suitable to send the cold water (at a temperature of $15 \div 16$ °C).

[0071] Return of the water, heated in passing within the radiating panels 28, to the cooling unit 33 is ensured by a tenth duct 37, which affects the second duct 3b upstream of the second flow control valve 5b.

[0072] The operation of the cooling system requires the closure of the first and second valves 5a and 5b in order to cut off the boiler 4; the lockshield valve 8 is preferably arranged in a fully open position, so as to exclude circulation of water in the first circuit 9.

[0073] As shown in Figure 1, one manner for fully avoiding any circulation in the first circuit 9 consists in providing the first tee 14 at a lower height than the lockshield valve 8, so as to produce a head or riser, designated by the reference numeral 38, which is suitable to facilitate the passage of the water through said lockshield valve.

[0074] Use of the invention entails that the installer places the compartment 2, which contains the components and the distribution and adjustment elements described above, in the preset location (for example, but not necessarily, in a cupboard or recessed into a wall).

[0075] The installer must then merely provide the hydraulic connections for delivery and return to the boiler and to the heating elements and the electrical connections from any external control and monitoring devices (for example external probes and control panels) to the electrical panel 30.

[0076] It is thus evident that the invention has achieved the intended aim and objects, a module for distributing heating or cooling water for a heating system of a building having been devised which allows quick and easy installation of such heating system.

[0077] The installation does not require highly specialized personnel, since most of the hydraulic and electrical connections have already been provided during the production of the module.

[0078] The invention therefore allows to provide easy, efficient, unified and simultaneous management of a plurality of high- and low-temperature circuits, and to use the same system for summer cooling.

[0079] By way of the above described module it is possible to greatly reduce both installation times and installation costs.

[0080] Finally, the installation is compact, reliable over time and aesthetically pleasant, since all the adjustment and control elements are located inside the compartment.

[0081] The invention is of course susceptible of numerous modifications and variations, all of which are within the scope of the appended claims .

[0082] Thus, for example, it is possible to provide a module in which one or both of the first and second manifolds 18 and 35 are replaced with ordinary pipes, preferably offset with respect to the plane on which the other pipes lie.

[0083] Although this solution is less valid from the point of view of robustness and thermal efficiency of the system, it is simpler and cheaper.

[0084] Likewise, the mechanical and electrical adjustment of the heating system can be the most appropriate according to the specific requirements of the installer and/or user.

[0085] The materials used, as well as the dimensions that constitute the individual components of the invention, may of course be more pertinent according to specific requirements.

[0086] The various means for performing certain different functions must not coexist certainly only in relation to the illustrated embodiment but can be present per se in many embodiments, even if such embodiments have not been illustrated.

[0087] The disclosures in San Marino Patent Application No. SM-A-200100020 from which this application claims priority are incorporated herein by reference.

[0088] Where technical features mentioned in any claim are followed by reference signs, those reference signs have been included for the sole purpose of increasing the intelligibility of the claims and accordingly, such reference signs do not have any limiting effect on the interpretation of each element identified by way of example by such reference signs.

Claims

1. A distribution module, particularly for distributing heating or cooling water, **characterized in that** it comprises a containment compartment for a plurality of ducts suitable to connect at least one first high-temperature circuit and/or one second low-temperature circuit, which are mutually connected preferably by means of at least one adjustment valve and a calibration valve. 5
2. The distribution module according to claim 1, **characterized in that** it comprises a panel for the electrical wiring of said valves. 10
3. The distribution module according to claim 1, **characterized in that** said compartment comprises a first duct for the inflow of hot water arriving from an external heat source, such as a boiler. 15
4. The distribution module according to claim 3, **characterized in that** proximate to said first duct there is a second duct for returning to said heat source the water circulated in at least one of said at least one first and second circuits. 20
5. The distribution module according to one or more of the preceding claims, **characterized in that** said first duct comprises a portion or segment that can be replaced with a second pump, arranged in series to said first pump and suitable to ensure the correct feeding of said first circuit. 25
6. The distribution module according to one or more of the preceding claims, wherein said heat source comprises a first feeder pump, **characterized in that** said compartment comprises a third pump suitable to circulate water in said second low-temperature circuit. 30
7. The distribution module according to one or more of the preceding claims, **characterized in that** said first high-temperature circuit is suitable to distribute heating water to one or more heating bodies, such as radiators and/or fan coils. 35
8. The distribution module according to one or more of the preceding claims, **characterized in that** said second low-temperature circuit is suitable to distribute heating or cooling water to one or more radiating panels, of the floor- or wall-mounted type. 40
9. The distribution module according to one or more of the preceding claims, **characterized in that** said first duct is affected by a third duct for connection to said adjustment valve, which is constituted by a mixing valve such as a three-way valve. 45
10. The distribution module according to claims 1 and 9, **characterized in that** along said third duct there is said calibration valve, which is constituted by a micrometric lockshield valve suitable to adjust the flow-rate of hot water that circulates in said first high-temperature circuit. 50
11. The distribution module according to one or more of the preceding claims, **characterized in that** said compartment comprises a fourth duct that allows the outflow of water from said heating bodies toward a first tee located along said third duct. 55
12. The distribution module according to claims 1 and 11, **characterized in that** said first tee between said fourth and third ducts is arranged downstream of said calibration valve.
13. The distribution module according to one or more of the preceding claims, **characterized in that** it comprises, along said fourth duct, a first one-way valve which is arranged upstream of said first tee between said fourth and third ducts and allows the water to circulate in said first circuit only clockwise.
14. The distribution module according to one or more of the preceding claims, **characterized in that** the extent of the opening of said calibration valve determines the flow-rate of water diverted toward said mixing valve.
15. The distribution module according to claims 1 and 14, **characterized in that** when said calibration valve is fully open, the flow-rate along said first duct is approximately equal to zero, since said calibration valve, when open, has much lower load losses than those generated by said first circuit.
16. The distribution module according to one or more of the preceding claims, **characterized in that** said mixing valve diverts the incoming water into a fifth duct for connection to a first end of a first manifold, which is advantageously arranged horizontally.
17. The distribution module according to claims 1 and 16, **characterized in that** said second duct for returning the water to said heat source is connected to a second end of said manifold.
18. The distribution module according to one or more of the preceding claims, **characterized in that** it comprises a sixth duct for connection between said radiating panels and said mixing valve.
19. The distribution module according to one or more of the preceding claims, **characterized in that** a second one-way valve is arranged along said sixth duct and allows circulation of the water in said sec-

ond circuit exclusively clockwise.

20. The distribution module according to one or more of the preceding claims, **characterized in that** it comprises a seventh bypass duct for mutually connecting said sixth duct and an eighth feed duct for said radiating panels, which is connected to said third duct, downstream of said first tee. 5
21. The distribution module according to claims 1 and 20, **characterized in that** said seventh duct is suitable to send at least part of the water flow-rate leaving said second one-way valve toward a second tee, between said seventh and eighth ducts, which is located upstream of a third feed pump for said second circuit. 10
22. The distribution module according to claims 1 and 21, **characterized in that** said third pump circulates water between said sixth, seventh and eighth ducts and said radiating panels. 15
23. The distribution module according to one or more of the preceding claims, **characterized in that** said mixing valve adjusts the inflow of water from said third duct into said eighth duct and also proportionally adjusts the inflow of water in input from said sixth duct, so as to ensure a substantially constant flow-rate along said fifth duct. 25
24. The distribution module according to one or more of the preceding claims, **characterized in that** said mixing valve, by adjusting the flow-rates of hot water arriving from said third duct and of cooled water arriving from said radiating panels, determines the temperature of the water in output from said eighth duct. 30
25. The distribution module according to one or more of the preceding claims, **characterized in that** said mixing valve is controlled by said electrical panel, integrated in said module, according to one or more temperature sensing devices, such as a room thermostat or a capillary probe. 35
26. The distribution module according to one or more of the preceding claims, **characterized in that** it comprises one or more zone valves, such as "on/off" or "fully open or fully closed" valves, for selectively sending water from said first and/or eighth ducts to said heating bodies and/or radiating panels. 40
27. The distribution module according to one or more of the preceding claims, **characterized in that** the adjustment of said mixing valve is performed by means of a first capillary probe which is suitable to read the temperature of the water at the delivery of 45

said third pump and to send the corresponding signal to a thermostatic control actuator for said mixing valve, depending on a reference temperature preset by the user.

28. The distribution module according to one or more of the preceding claims, **characterized in that** said mixing valve is adjusted by means of an electric servo control, controlled by an electronic controller which is connected to said electrical panel, on the basis of signals sent by a second temperature probe located at the delivery of said third pump, and by a third temperature probe for detecting the external temperature. 5
29. The distribution module according to one or more of the preceding claims, **characterized in that** said first and second ducts are preferably controlled by a first flow control valve and a second flow control valve, such as a ball valve. 10
30. The distribution module according to one or more of the preceding claims, **characterized in that** it comprises a third flow control valve and a fourth flow control valve, located respectively proximate to the outlet of said first duct and the inlet of said fourth duct. 15
31. The distribution module according to one or more of the preceding claims, **characterized in that** it comprises a fifth flow control valve and a sixth flow control valve, which are located proximate to the outlet of said eighth duct and the inlet of said sixth duct. 20
32. The distribution module according to one or more of the preceding claims, **characterized in that** it comprises a plurality of separate ducts suitable to allow the interconnection of a known type of water cooling unit, which is provided with a fourth built-in feed pump. 25
33. The distribution module according to claims 1 and 32, **characterized in that** said separate ducts are constituted by a second manifold which is arranged, along said first duct, downstream of said first flow control valve and is fed by a ninth duct connected upstream to said cooling unit. 30
34. The distribution module according to claims 1 and 33, **characterized in that** it comprises a tenth duct for connection between said second duct and said refrigeration unit, suitable for the return of the water heated in said radiating panels into said cooling unit. 35

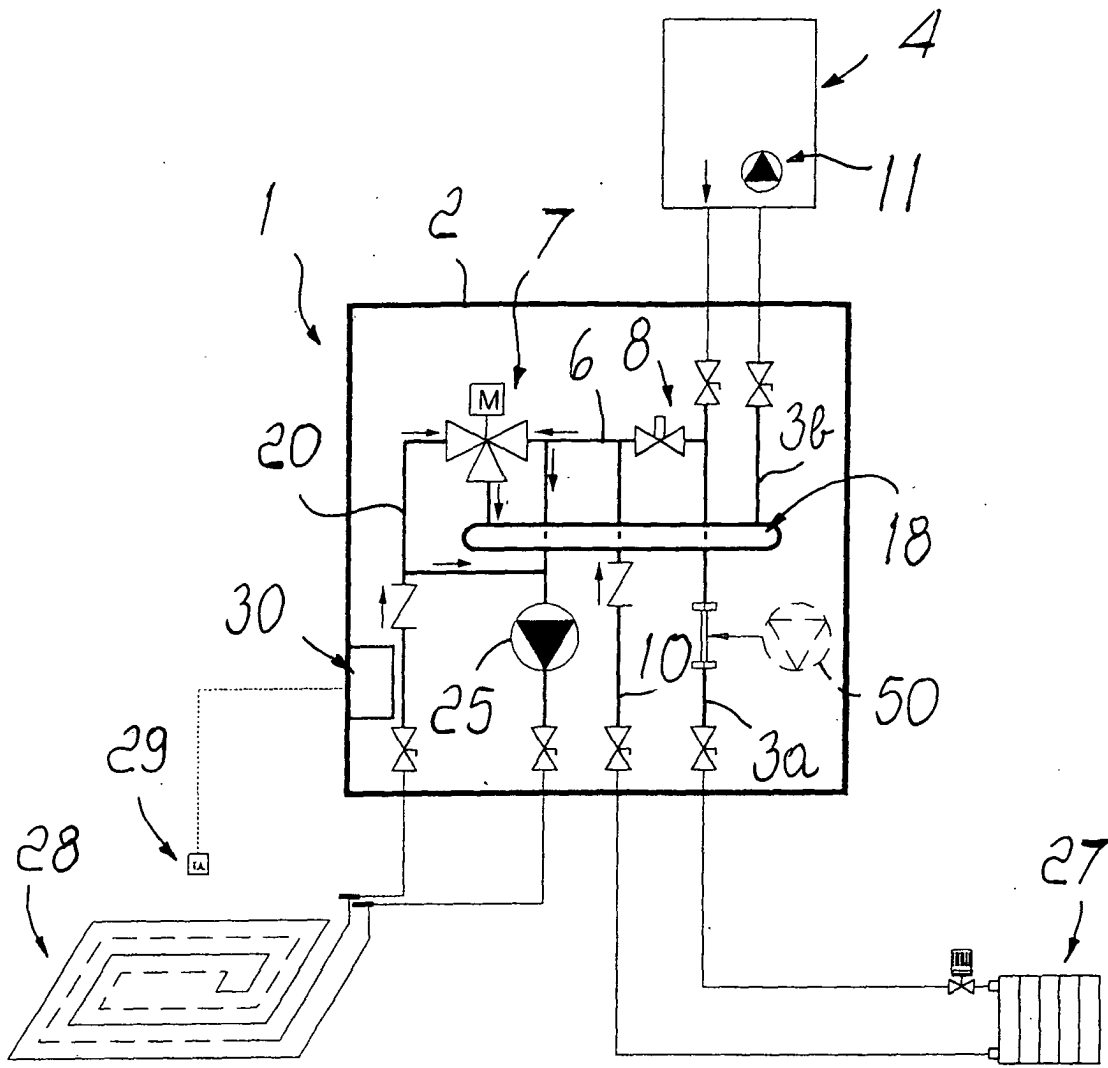

Fig. 2

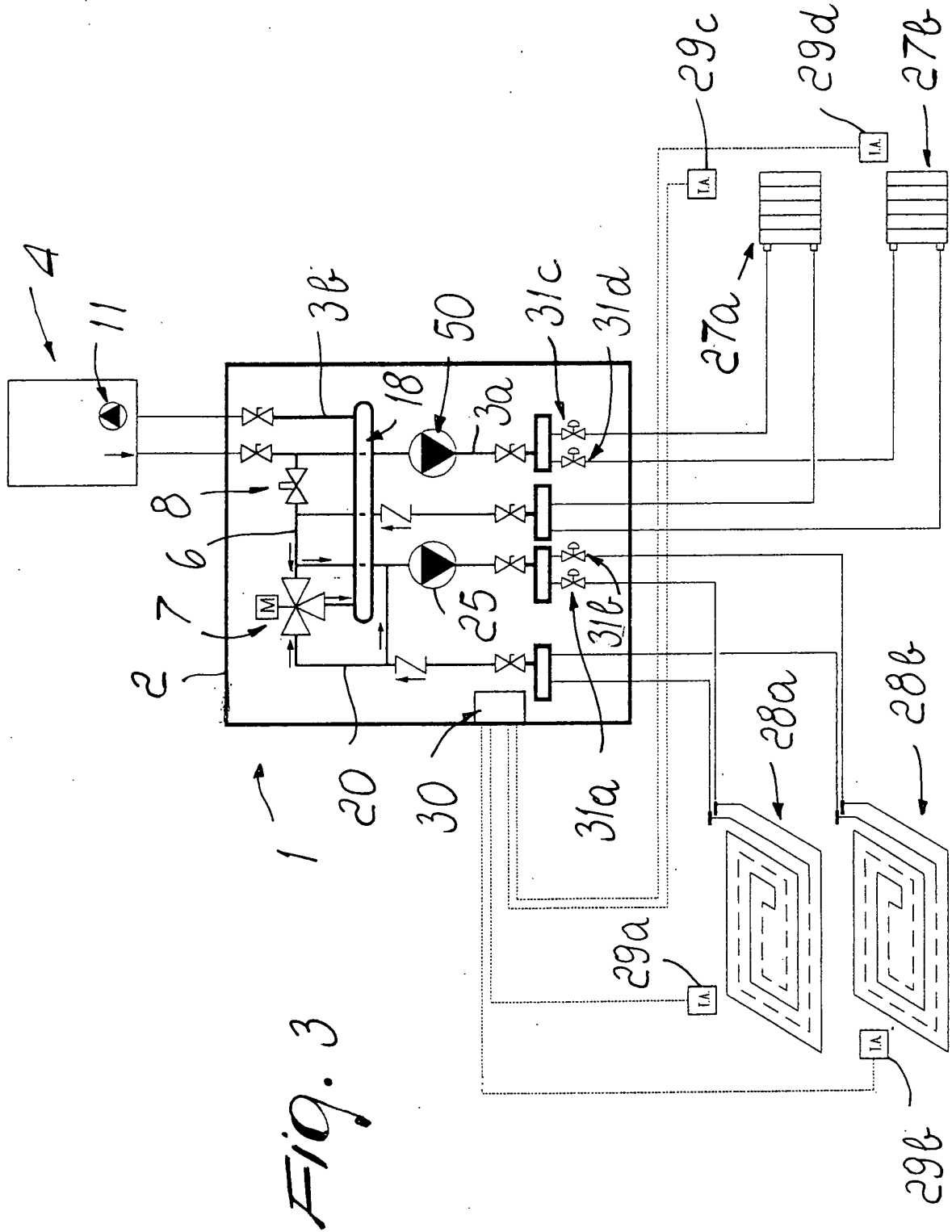

Fig. 3

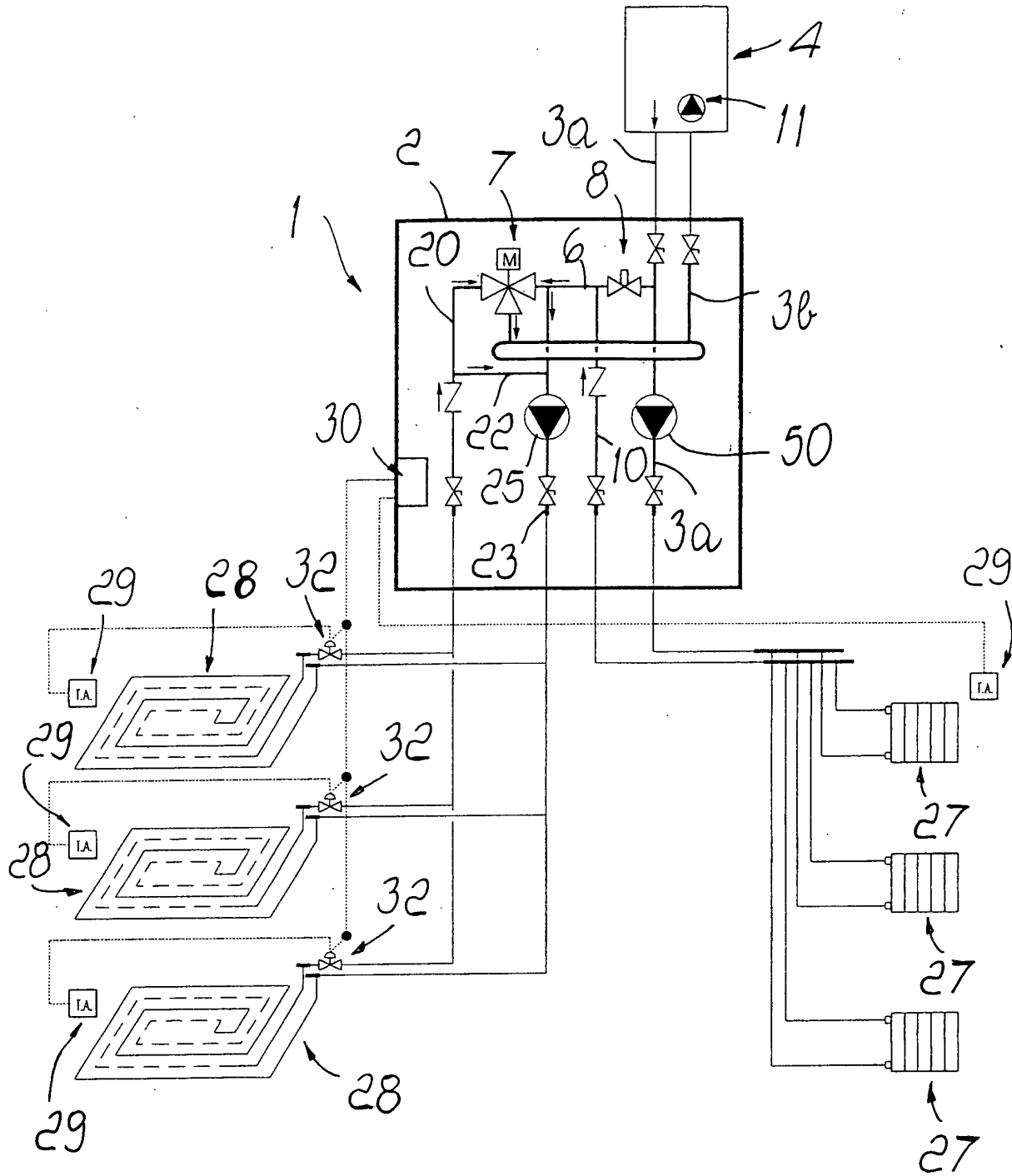
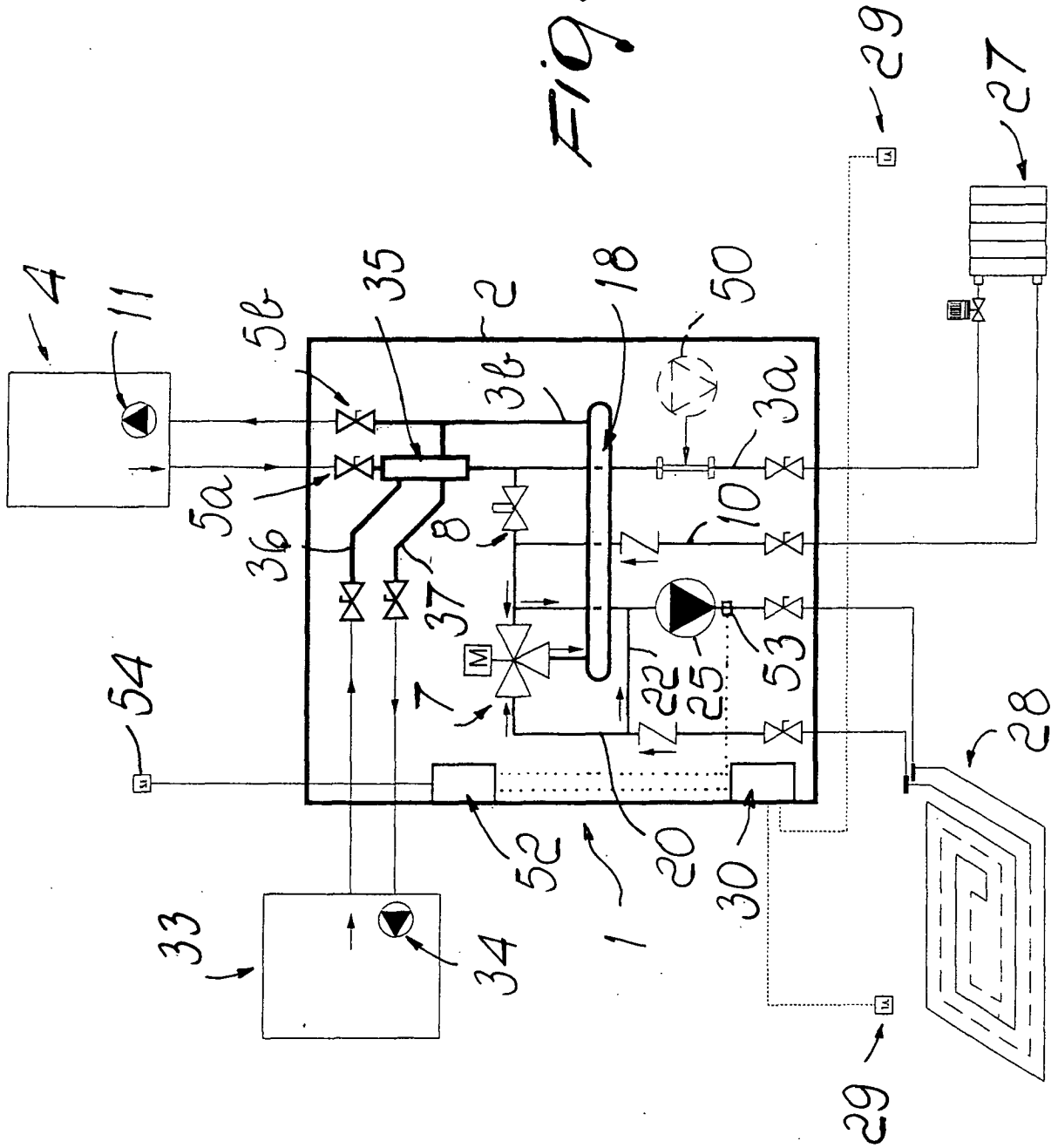

FIG. 4

Fig. 5



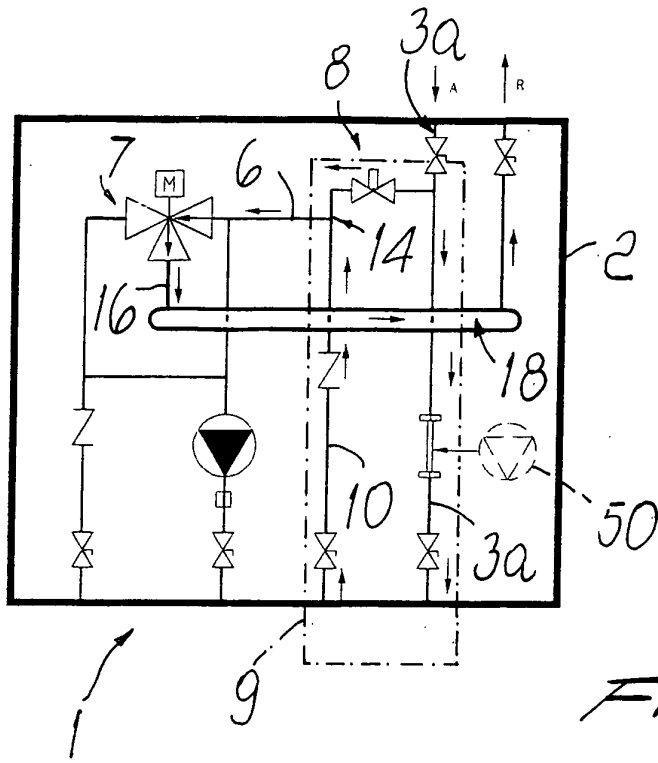

FIG. 6

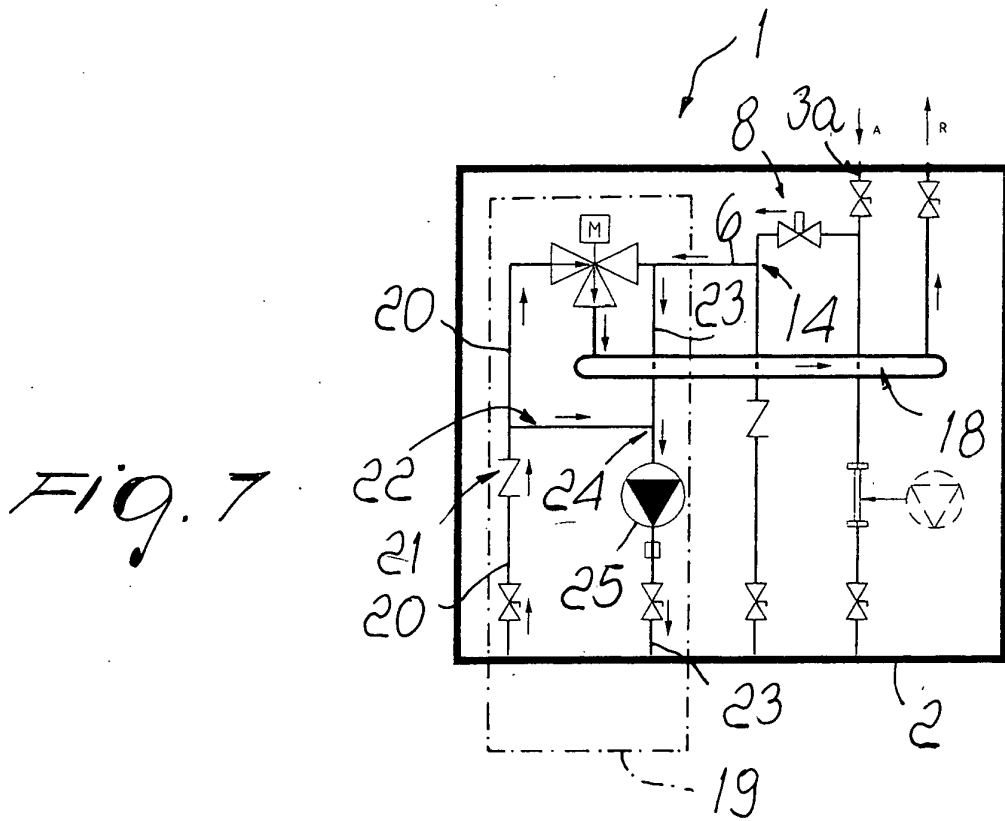

FIG. 7

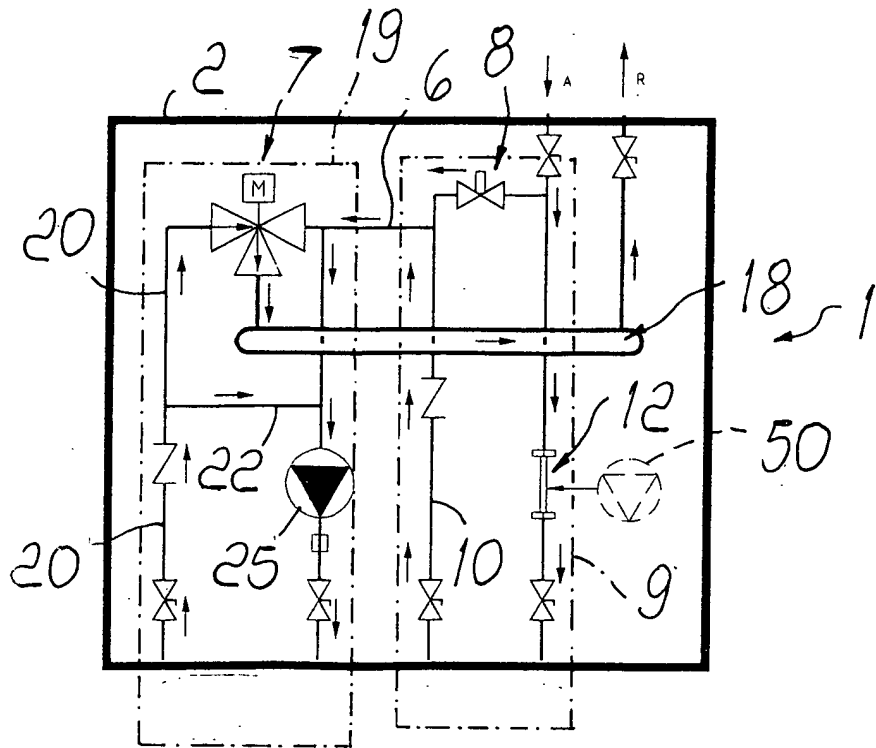

Fig. 8



European Patent
Office

EUROPEAN SEARCH REPORT

Application Number
EP 02 01 6826

DOCUMENTS CONSIDERED TO BE RELEVANT			
Category	Citation of document with indication, where appropriate, of relevant passages	Relevant to claim	CLASSIFICATION OF THE APPLICATION (Int.Cl.7)
X	FR 2 733 822 A (FINANC & COMM CHABLAIS) 8 November 1996 (1996-11-08)	1-9,14, 18,25, 27-31	F24D3/10 F24H9/12
Y	* page 8, line 8 - page 12, line 36; figure 1 *	10-12,26	
A	---	13, 15-17, 19-24	
Y	EP 0 806 612 A (COMPEX BAUBERATUNGS UND AUSFUE) 12 November 1997 (1997-11-12) * the whole document *	10-12,26	
X	DE 196 44 773 A (KERMI GMBH) 30 April 1998 (1998-04-30)	1,3,4,7	
A	* figures 1,5-7 *	9-31	
X	EP 1 039 249 A (KERMI GMBH) 27 September 2000 (2000-09-27)	1,3,4,7, 8	
A	* figures 1-6 *	9-31	
X	EP 0 957 319 A (BAUNACH HANS GEORG) 17 November 1999 (1999-11-17)	1,3,4,7	TECHNICAL FIELDS SEARCHED (Int.Cl.7)
A	* the whole document *	9-31	F24D F24H
A	EP 0 309 440 A (SCHWARZ ALOIS) 29 March 1989 (1989-03-29)	26	
A	* figure 1 *		
A	US 5 284 204 A (MORGAN DEAN T) 8 February 1994 (1994-02-08)	32-34	
A	* column 3, line 44-68; figure 1 *		
A	DE 34 04 849 A (ZORTEA REMBERT) 16 August 1984 (1984-08-16)	32-34	
A	* page 12, paragraph 2 - page 13, paragraph 1; figure 8 *		
The present search report has been drawn up for all claims			
Place of search		Date of completion of the search	Examiner
MUNICH		20 January 2003	Leclaire, T
CATEGORY OF CITED DOCUMENTS			
X : particularly relevant if taken alone		T : theory or principle underlying the invention	
Y : particularly relevant if combined with another document of the same category		E : earlier patent document, but published on, or after the filing date	
A : technological background		D : document cited in the application	
O : non-written disclosure		L : document cited for other reasons	
P : intermediate document		& : member of the same patent family, corresponding document	

EPC FORM 1503 03 B2 (P04001)

**ANNEX TO THE EUROPEAN SEARCH REPORT
ON EUROPEAN PATENT APPLICATION NO.**

EP 02 01 6826

This annex lists the patent family members relating to the patent documents cited in the above-mentioned European search report. The members are as contained in the European Patent Office EDP file on the European Patent Office is in no way liable for these particulars which are merely given for the purpose of information.

20-01-2003

Patent document cited in search report		Publication date	Patent family member(s)	Publication date
FR 2733822	A	08-11-1996	FR 2733822 A1	08-11-1996
EP 0806612	A	12-11-1997	DE 29609069 U1 EP 0806612 A2	29-08-1996 12-11-1997
DE 19644773	A	30-04-1998	DE 19644773 A1 AT 195369 T AU 6910298 A CZ 9901482 A3 DE 29704807 U1 DE 29724080 U1 DE 59702160 D1 DK 934492 T3 WO 9819111 A1 EP 0934492 A1 PL 333067 A1	30-04-1998 15-08-2000 22-05-1998 15-12-1999 05-06-1997 17-02-2000 14-09-2000 18-12-2000 07-05-1998 11-08-1999 08-11-1999
EP 1039249	A	27-09-2000	DE 19912821 A1 EP 1039249 A2	19-10-2000 27-09-2000
EP 0957319	A	17-11-1999	DE 19821256 C1 EP 0957319 A2 PL 333089 A1	16-09-1999 17-11-1999 22-11-1999
EP 0309440	A	29-03-1989	AT 71452 T DE 3867581 D1 EP 0309440 A2	15-01-1992 20-02-1992 29-03-1989
US 5284204	A	08-02-1994	NONE	
DE 3404849	A	16-08-1984	AT 382709 A AT 48683 A DE 3404849 A1	10-04-1987 15-08-1986 16-08-1984

EPO FORM P4459

For more details about this annex : see Official Journal of the European Patent Office, No. 12/82