



INTERNATIONAL APPLICATION PUBLISHED UNDER THE PATENT COOPERATION TREATY (PCT)

<p>(51) International Patent Classification ⁷ : A46B 9/06, 15/00</p>	<p>A1</p>	<p>(11) International Publication Number: WO 00/64307 (43) International Publication Date: 2 November 2000 (02.11.00)</p>												
<p>(21) International Application Number: PCT/JP00/01737 (22) International Filing Date: 22 March 2000 (22.03.00)</p> <p>(30) Priority Data: <table border="0"> <tr> <td>11/114824</td> <td>22 April 1999 (22.04.99)</td> <td>JP</td> </tr> <tr> <td>11/114825</td> <td>22 April 1999 (22.04.99)</td> <td>JP</td> </tr> <tr> <td>11/114826</td> <td>22 April 1999 (22.04.99)</td> <td>JP</td> </tr> <tr> <td>11/114827</td> <td>22 April 1999 (22.04.99)</td> <td>JP</td> </tr> </table> <p>(71) Applicant (for all designated States except US): KAO CORPORATION [JP/JP]; 14-10, Nihonbashikayabacho 1-chome, Chuo-ku, Tokyo 103-8210 (JP).</p> <p>(72) Inventors; and (75) Inventors/Applicants (for US only): SUZUKI, Akira [JP/JP]; Kao Corporation Research Laboratories, 1-3, Bunka 2-chome, Sumida-ku, Tokyo 131-8501 (JP). MAEDA, Kouji [JP/JP]; Kao Corporation Research Laboratories, 1-3, Bunka 2-chome, Sumida-ku, Tokyo 131-8501 (JP). MIURA, Eiki [JP/JP]; Kao Corporation Research Laboratories, 2606, Akabane, Ichikaimachi, Haga-gun, Tochigi 321-3497 (JP). IMAI, Naoki [JP/JP]; Kao Corporation Research Laboratories, 2606, Akabane, Ichikaimachi, Haga-gun, Tochigi 321-3497 (JP). KUBO, Mitsuyuki</p> </p>		11/114824	22 April 1999 (22.04.99)	JP	11/114825	22 April 1999 (22.04.99)	JP	11/114826	22 April 1999 (22.04.99)	JP	11/114827	22 April 1999 (22.04.99)	JP	<p>[JP/JP]; Kao Corporation Research Laboratories, 2606, Akabane, Ichikaimachi, Haga-gun, Tochigi 321-3497 (JP).</p> <p>(74) Agents: ARUGA, Mitsuyuki et al.; Kyodo Building, 3-6, Nihonbashiningyocho 1-chome, Chuo-ku, Tokyo 103-0013 (JP).</p> <p>(81) Designated States: CN, US, European patent (DE, FR, GB).</p> <p>Published With international search report.</p>
11/114824	22 April 1999 (22.04.99)	JP												
11/114825	22 April 1999 (22.04.99)	JP												
11/114826	22 April 1999 (22.04.99)	JP												
11/114827	22 April 1999 (22.04.99)	JP												

(54) Title: TOOTHBRUSH

(57) Abstract

The invention relates to a toothbrush comprising rubber-like bar bristles set with an inclination toward the outside; a toothbrush comprising rubber-like bar bristles set alternately with bristle bundles in an upright position with their tips projected from the tips of the bristle bundles; a toothbrush comprising rubber-like bar bristles each having a cross-sectional shape that its face is wider at the peripheral side of a handle head than at the central side thereof; a toothbrush comprising a mixed bristle part composed of rubber-like bar bristles and soft bristle bundles, said mixed part being formed in a peripheral portion on the bristle-setting surface, and hard bristle bundles set in the central portion; and a toothbrush comprising rubber-like bar bristles set with the bases thereof connected to each other only on the side of the back surface of a handle head. According to the toothbrushes of the invention, a high massaging effect on gums, particularly, peripheries and papillae thereof is achieved, to say nothing of removal of sordes on teeth.

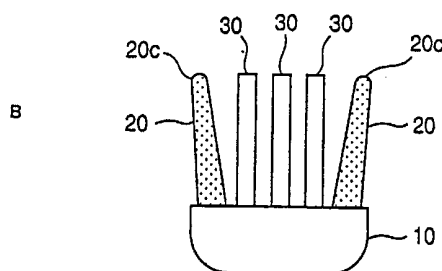
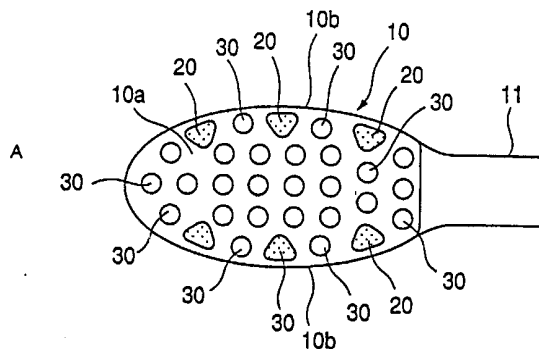

FOR THE PURPOSES OF INFORMATION ONLY

Codes used to identify States party to the PCT on the front pages of pamphlets publishing international applications under the PCT.

AL	Albania	ES	Spain	LS	Lesotho	SI	Slovenia
AM	Armenia	FI	Finland	LT	Lithuania	SK	Slovakia
AT	Austria	FR	France	LU	Luxembourg	SN	Senegal
AU	Australia	GA	Gabon	LV	Latvia	SZ	Swaziland
AZ	Azerbaijan	GB	United Kingdom	MC	Monaco	TD	Chad
BA	Bosnia and Herzegovina	GE	Georgia	MD	Republic of Moldova	TG	Togo
BB	Barbados	GH	Ghana	MG	Madagascar	TJ	Tajikistan
BE	Belgium	GN	Guinea	MK	The former Yugoslav Republic of Macedonia	TM	Turkmenistan
BF	Burkina Faso	GR	Greece			TR	Turkey
BG	Bulgaria	HU	Hungary	ML	Mali	TT	Trinidad and Tobago
BJ	Benin	IE	Ireland	MN	Mongolia	UA	Ukraine
BR	Brazil	IL	Israel	MR	Mauritania	UG	Uganda
BY	Belarus	IS	Iceland	MW	Malawi	US	United States of America
CA	Canada	IT	Italy	MX	Mexico	UZ	Uzbekistan
CF	Central African Republic	JP	Japan	NE	Niger	VN	Viet Nam
CG	Congo	KE	Kenya	NL	Netherlands	YU	Yugoslavia
CH	Switzerland	KG	Kyrgyzstan	NO	Norway	ZW	Zimbabwe
CI	Côte d'Ivoire	KP	Democratic People's Republic of Korea	NZ	New Zealand		
CM	Cameroon			PL	Poland		
CN	China	KR	Republic of Korea	PT	Portugal		
CU	Cuba	KZ	Kazakstan	RO	Romania		
CZ	Czech Republic	LC	Saint Lucia	RU	Russian Federation		
DE	Germany	LI	Liechtenstein	SD	Sudan		
DK	Denmark	LK	Sri Lanka	SE	Sweden		
EE	Estonia	LR	Liberia	SG	Singapore		

DESCRIPTION

TOOTHBRUSH

5 TECHNICAL FIELD

The present invention relates to toothbrushes capable of effectively massaging gums together with the removal of sordes on teeth, and particularly to toothbrushes having rubber-like bar bristles for massaging
10 gums.

BACKGROUND ART

As toothbrushes for massaging gums, there have been known, for example, a toothbrush provided with tongue
15 piece-like rubber massaging members into longitudinal edge portions on the bristle-setting surface of a handle head (Japanese Utility Model Application Laid-Open No. 1738/1972), a toothbrush provided with rubber-made bristles the tips of which are curved outward (Japanese
20 Utility Model Application Laid-Open No. 35527/1987), etc. However, these toothbrushes have involved the following respective problems. In the case of the former toothbrush, its massaging effect on gums can be scarcely achieved when the teeth are brushed in vertical and oblique directions,
25 setting aside the brushing in lateral directions, since the rubber massaging members are in the form of a tongue piece and projected only up to a position lower than

bristle bundles. In the case of the latter toothbrush,
force is hard to transmit to gums because the tips of the
rubber-made bristles are curved from the beginning, and so
only low massaging effect can be achieved. There has not
5 been yet achieved under the circumstances any fully
satisfactory massaging effect on gums by the conventional
toothbrushes.

It is an object of the present invention to provide
a toothbrush which can solve such problems of the
10 conventional toothbrushes as described above and achieve a
high massaging effect on gums, particularly, peripheries
and papillae thereof.

DISCLOSURE OF THE INVENTION

15 The above object of the present invention can be
achieved by a toothbrush comprising rubber-like bar
bristles set with an inclination toward the outside into
at least parts of longitudinal edge portions on the
bristle-setting surface of a handle head.

20 The above object of the present invention can also
be achieved by a toothbrush comprising rubber-like bar
bristles set alternately with bristle bundles in an
upright position with their tips projected from the tips
of the bristle bundles into at least parts of longitudinal
25 edge portions on the bristle-setting surface of a handle
head.

The above object of the present invention can

further be achieved by a toothbrush comprising rubber-like bar bristles each having a cross-sectional shape that its face is wider at the peripheral side of a handle head than at the central side thereof, which are set into at least
5 parts of longitudinal edge portions on the bristle-setting surface of the handle head.

The above object of the present invention can still further be achieved by a toothbrush comprising a mixed bristle part composed of rubber-like bar bristles and
10 bristle bundles having softness to an extent that gums are not damaged, said mixed part being formed in a peripheral portion on the bristle-setting surface of a handle head, and a bristle part composed of bristle bundles harder than the bristle bundles set in the peripheral portion, said
15 bristle part being formed in the central portion on the bristle-setting surface of the handle head.

The above object of the present invention can yet still further be achieved by a toothbrush comprising rubber-like bar bristles, the bases of which are connected
20 to each other only on the side of the back surface of a handle head, set into at least parts of the bristle-setting surface of the handle head.

BRIEF DESCRIPTION OF THE DRAWINGS

25 Figs. 1A and 1B illustrate a toothbrush according to a first embodiment of the present invention, Fig. 1A is a schematic plan view illustrating a handle head thereof,

and Fig. 1B is a schematic side elevation thereof viewed from the left side.

Fig. 2 is an enlarged cross-sectional view illustrating an example of a rubber-like bar bristle.

5 Figs. 3A and 3B illustrate a toothbrush according to a second embodiment of the present invention, Fig. 3A is a schematic plan view illustrating a handle head thereof, and Fig. 3B is a schematic side elevation thereof viewed from the left side.

10 Figs. 4A and 4B illustrate a toothbrush according to a third embodiment of the present invention, Fig. 4A is a schematic plan view illustrating a handle head thereof, and Fig. 4B is a schematic side elevation thereof viewed from the left side.

15 Fig. 5 is a schematic plan view illustrating a handle head of a toothbrush according to a fourth embodiment of the present invention.

Fig. 6 is a sectional view illustrating principal parts in a handle head of a toothbrush according to a
20 fifth embodiment of the present invention.

Figs. 7A, 7B and 7C illustrate setting examples of rubber-like bar bristles, Figs. 7A and 7B are sectional views illustrating principal parts in a handle head, in which rubber-like bar bristles are set in connection with
25 each other at both sides of the handle head, and Fig. 7C is a sectional view illustrating principal parts in a handle head, in which rubber-like bar bristles are set

independently of each other.

Description of characters:

- 10: Handle head
 - 10a: Bristle-setting surface
 - 5 10b: Longitudinal edge portion
 - 10c: Front end
 - 10d: End on a handle side
 - 10e: Back surface
- 11: Handle
- 10 12: Through-hale
 - 20: Rubber-like bar bristle
 - 20a: Base
 - 20b: Bristle part
 - 20c: Bristle top (tip)
- 15 21: Connecting member
 - 30: Bristle bundle
 - 30a: Bristle bundle (soft)
 - 30b: bristle bundle (hard)

20 BEST MODE FOR CARRYING OUT THE INVENTION

When rubber-like bar bristles are set with an inclination toward the outside in the present invention, the angle of inclination is preferably 2 to 15°, particularly 2 to 5° in an outside direction of a longitudinal edge of a handle head based on a line perpendicular to the bristle-setting surface of the handle head. In this case, it is advantageous that at least parts

of the rubber-like bar bristles are projected from the tips of the bristle bundles set into the bristle-setting surface, since they become easy to strike on peripheral gingivae and interdental papillae, so that the peripheries and papillae of gums can be massaged at the same time and with high efficiency. By the way, the degree of the projection is preferably about 0.5 to 3.0 mm. In this case, it is further desirable from the viewpoint of achieving a more effective massaging effect that the rubber-like bar bristles be set alternately with the bristle bundles into at least parts of longitudinal edge portions on the bristle-setting surface, since the rubber-like bar bristles are prevented from being concentrated at one place, so that they become easy to reach interdental papillae.

On the other hand, when the rubber-like bar bristles are not inclined in the outside direction, they are preferably set alternately with bristle bundles in an upright position with their tips projected from the tips of the bristle bundles by about 0.5 to 3.0 mm into at least parts of longitudinal edge portions on the bristle-setting surface.

When rubber-like bar bristles each having a cross-sectional shape that its face is wider at the peripheral side of a handle head than at the central side thereof, are set in the present invention, any rubber-like bar bristles may be used irrespective of their specific shape

so far as they each have a cross-sectional shape that its face is wider at the peripheral side than at the central side in order for the rubber-like bar bristle to be easier to deflect in the outside direction of the handle head than in the inside direction thereof upon use. However, those having substantially a triangular or trapezoidal shape in section are particularly preferred because they are excellent in the ability to deflect in the outside direction. In this case, it is also preferred from the viewpoint of having a soft feel in the mouth that each corner be suitably rounded. In this case, the rubber-like bar bristles may be in the form of a square bar having the same thickness on the whole. However, it is further preferred from the viewpoint of achieving an excellent massaging effect due to deflection elasticity that the square bar be tapered off upward, and from the viewpoint of having a soft feel like the above that the tip thereof be also suitably rounded.

When a mixed bristle part composed of rubber-like bar bristles and bristle bundles having softness to an extent that gums are not damaged is formed in a peripheral portion on the bristle-setting surface of a handle head, and a bristle part composed of bristle bundles harder than the bristle bundles set in the peripheral portion is formed in the central portion on the bristle-setting surface of the handle head, it is simple and advantageous that a difference in hardness between the bristle bundles

set in the central portion and the bristle bundles set in the peripheral portion is made by, for example, suitably varying the resilience, length or thickness of the bristle bundles set in the central and peripheral portions, or the thickness of the individual bristles making up the bristle bundles irrespective of specific imparting means thereof. In this case, the soft bristle bundles set in the peripheral portion may also be formed in plural rows inward from the peripheral end. However, it is desirable from the viewpoint of achieving a high effect by the hard bristle bundles set in the central portion on removal of sordes on teeth that the soft bristle bundles be formed in only a row of the outermost row along the periphery of the bristle-setting surface. In this case, the rubber-like bar bristles set in combination with the soft bristle bundles set in the peripheral portion may be set over the overall periphery of the bristle-setting surface. However, it is further preferred from the viewpoint of achieving an efficient massaging effect on gums that they be set in only longitudinal edge portions on the bristle-setting surface.

When rubber-like bar bristles are set with the bases thereof connected to each other only on the side of the back surface of a handle head, it is preferred that a connected member of rubber-like bar bristles the bases of which have been connected to each other be set into the handle head in such a manner that the bristle parts of the

connected member are fitted into through-holes cut in the handle head from the side of the back surface of the handle head so as to project from the bristle-setting surface, since they can be set efficiently and certainly.

5

EXAMPLES

The present invention will hereinafter be described in further detail with reference to the drawings illustrating embodiments of the present invention.

10 Figs. 1A and 1B illustrate a first embodiment. Rubber-like bar bristles 20, the tips of which have been rounded, are set with an inclination of about 4° toward the outside from respective longitudinal edge portions 10b into the longitudinal edge portions 10b opposed to each other on the bristle-setting surface 10a of a handle head 10 connected to the tip of a handle 11. The tips of the rubber-like bar bristles 20 are arranged at substantially the same level as the tips of bristle bundles 30 set in an upright position into the bristle-setting surface 10a, and 15 moreover the rubber-like bar bristles 20 are set alternately with the bristle bundles 30 in the same row at the longitudinal edge portions 10b.

According to this embodiment, since the rubber-like bar bristle 20 is a straight bar not curved up to the tip, 25 force is easy to apply to gums in all of vertical, lateral and oblique directions, so that a high massaging effect is achieved, and moreover the bar bristles 20 do not prevent

the bristle bundles 30 set into the bristle-setting surface 10a from removing sordes on teeth, since they are inclined toward the outside.

The rubber-like bar bristles 20 each have a cross-sectional shape of substantially a triangular form that its face is wider at the peripheral side of the handle head 10 than at the central side, wherein a corner thereof is opposed to the central side, and a side corresponding to it is located substantially in parallel with the longitudinal edge portion 10b of the handle head 10 in order for the rubber-like bar bristles to be easier to deflect in the outside direction of the handle head 10 than upon use. By the way, the corners of the substantial triangle are suitably rounded so as to have a soft feel.

Fig. 2 illustrates another example of the cross-sectional shape of the rubber-like bar bristle 20. This bar bristle has substantially a trapezoidal shape and is set into the bristle-setting surface with the shorter side 20x of the parallel sides located on the central side of the handle head 10 and with the longer side 20y thereof located on the peripheral side of the handle head 10.

The rubber-like bar bristles 20 are gradually tapered off upward, and tips 20c thereof are rounded. Incidentally, the rubber-like bar bristles 20 may be formed irrespective of materials such as rubber and rubber-like synthetic resins so far as the material has deflection resilience. However, preferable examples of the

material include styrene-butadiene rubber, ethylene-propylene rubber and silicone rubber.

Reference numeral 30 indicates a bristle bundle, and a proper number of the bristle bundles is set into the bristle-setting surface 10a of the handle head 10 as before. Incidentally, as a material for the bristle bundles 30, natural fur or artificial bristles made of nylon, polybutylene terephthalate or the like may be used irrespective of the kind of the material.

Fig. 3 illustrates a second embodiment, and the toothbrush of this embodiment is constructed in the same manner as in the first embodiment illustrated in Figs. 1A and 1B except that the tips of the rubber-like bar bristles 20 are projected by about 2 mm from the tips of the bristle bundles 30 set in an upright position into the bristle-setting surface 10a. More specifically, the rubber-like bar bristles 20 according to this embodiment are set with an inclination toward the outside of the longitudinal edge portions 10b on the bristle-setting surface 10a and with the tips thereof projected from the bristle bundles 30.

According to this embodiment, a far excellent massaging effect on peripheries and papillae of gums is achieved, since the rubber-like bar bristles 20 are projected from the bristle bundles 30.

Fig. 4 illustrates a third embodiment, and the toothbrush of this embodiment is constructed in the same

manner as in the second embodiment illustrated in Figs. 3A and 3B except that the rubber-like bar bristles 20 are set in an upright position into the bristle-setting surface 10a without inclining them. More specifically, the rubber-like bar bristles 20 according to this embodiment are set alternately with bristle bundles 30 in an upright position into the bristle-setting surface 10a with the tips thereof projected from the tips of the bristle bundles 30.

According to this embodiment, an excellent massaging effect on peripheries and papillae of gums is achieved, since the rubber-like bar bristles 20 are prevented from being concentrated at one place, and projected from the tips of the bristle bundles 30.

Fig. 5 illustrates a fourth embodiment, wherein bristle bundles 30a having softness to an extent that gums are not damaged and rubber-like bar bristles 20 are set alternately with each other by only one row in the same row along the periphery of the bristle-setting surface 10a excluding an end 10d of the bristle-setting surface 10a on the handle side. By the way, the rubber-like bar bristles 20 are set only into longitudinal edge portions 10b opposed to each other on the bristle-setting surface 10a, and not set into the front end 10c and the end 10d on the handle side.

A proper number of bristle bundles 30b prepared harder than the bristle bundles 30a set into the peripheral portion is set into the other portion on the

bristle-setting surface 10a, i.e., the central portion so as to achieve a sufficient effect on removal of sordes on teeth. In this embodiment, a difference in hardness between the bristle bundles 30b set in the central portion and the bristle bundles 30a set in the peripheral portion is made by suitably varying the resilience, length or thickness of the bristle bundles as described above. Incidentally, as materials for the bristle bundles 30a and 30b, natural fur or artificial bristles made of nylon, polybutylene terephthalate or the like may be used irrespective of the kind of the material as described above.

According to this embodiment, besides the fact that gums can be effectively massaged by the rubber-like bar bristles 20, the gums are not damaged because the bristle bundles 30a set into the peripheral portion are soft, and moreover a high effect can be achieved on removal of sordes on teeth because the bristle bundles 30b set in the central portion are hard.

Fig. 6 illustrates a fifth embodiment, wherein the bases 20a of the rubber-like bar bristles 20 set into the longitudinal edge portions 10b on the bristle-setting surface 10a are connected to each other only on the side of the back surface 10e of the handle head 10 through a connecting member 21. A material for the connecting member 21 may be different from the above-described material for the rubber-like bar bristles 20. However, the same

material is preferably used to integrally mold both.

Such a toothbrush can be produced with extreme efficiency by fitting a connected member of plural rubber-like bar bristles 20, the bases 20a of which have been
5 connected to each other through the connecting member 21, into through-holes 12 cut in advance in the handle head 10, into which the bristle bundles 30 have been set, from the side of the back surface 10e of the handle head 10 so as to project the bristle parts 20b of the rubber-like bar
10 bristles 20 from the bristle-setting surface 10a, thereby setting the connected member into the handle head 10.

According to this embodiment, since the bristle-setting surface 10a of the handle head 10 are exposed between the rubber-like bar bristles 20, the bristle
15 bundles 30 can also be set between the rubber-like bar bristles 20, so that the setting area of the bristle bundles is prevented from being extremely narrowed like the toothbrushes illustrated in Figs. 7A and 7B. Therefore, the toothbrush does not interfere with the effect of the
20 bristle bundles on removal of sordes on teeth, and moreover, a higher gum-massaging effect can be brought about by the rubber-like bar bristles 20. In addition, since the respective rubber-like bar bristles 20 are connected to each other on the side of the back surface
25 10e of the handle head 10, the rubber-like bar bristles 20 are prevented from falling off like the toothbrush illustrated in Fig. 7C.

INDUSTRIAL APPLICABILITY

When the toothbrushes according to the present invention are used, a high massaging effect on gums, particularly, peripheries and papillae thereof can be
5 achieved by the elastic sliding action of the rubber-like bar bristles, to say nothing of removal of sordes on teeth. Therefore, the toothbrushes also have an excellent effect on improvement and prevention of gingivitis and the like.

CLAIMS

1. A toothbrush comprising rubber-like bar bristles set with an inclination toward the outside into at least
5 parts of longitudinal edge portions on the bristle-setting surface of a handle head.

2. The toothbrush according to Claim 1, wherein at least parts of the rubber-like bar bristles are projected from the tips of bristle bundles set into the bristle-
10 setting surface.

3. The toothbrush according to Claim 1, wherein the rubber-like bar bristles and the bristle bundles are set alternately with each other into at least parts of the longitudinal edge parts on the bristle-setting surface.

4. A toothbrush comprising rubber-like bar bristles set alternately with bristle bundles in an upright position with their tips projected from the tips of the bristle bundles into at least parts of longitudinal edge portions on the bristle-setting surface of a handle head.
15

5. A toothbrush comprising rubber-like bar bristles each having a cross-sectional shape that its face is wider at the peripheral side of a handle head than at the central side thereof, which are set into at least parts of longitudinal edge portions on the bristle-setting surface
20 of the handle head.

6. A toothbrush comprising a mixed bristle part composed of rubber-like bar bristles and bristle bundles

having softness to an extent that gums are not damaged, said mixed part being formed in a peripheral portion on the bristle-setting surface of a handle head, and a bristle part composed of bristle bundles harder than the
5 bristle bundles set in the peripheral portion, said bristle part being formed in the central portion on the bristle-setting surface of the handle head.

7. The toothbrush according to Claim 6, wherein a difference in hardness between the bristle bundles set in
10 the central portion and the bristle bundles set in the peripheral portion is made by varying the resilience, length or thickness of the bristle bundles, or the thickness of the individual bristles making up the bristle bundles.

15 8. The toothbrush according to Claim 6, wherein the bristle bundles set in the peripheral portion are formed in only a row of the outermost row along the periphery of the bristle-setting surface.

20 9. A toothbrush comprising rubber-like bar bristles, the bases of which are connected to each other only on the side of the back surface of a handle head, set into at least parts of the bristle-setting surface of the handle head.

25 10. The toothbrush according to Claim 9, wherein a connected member of the rubber-like bar bristles, the bases of which have been connected to each other is set into the handle head in such a manner that the bristle

parts of the connected member are fitted into through-holes cut in advance in the handle head from the side of the back surface of the handle head so as to project from the bristle-setting surface.

Fig. 1

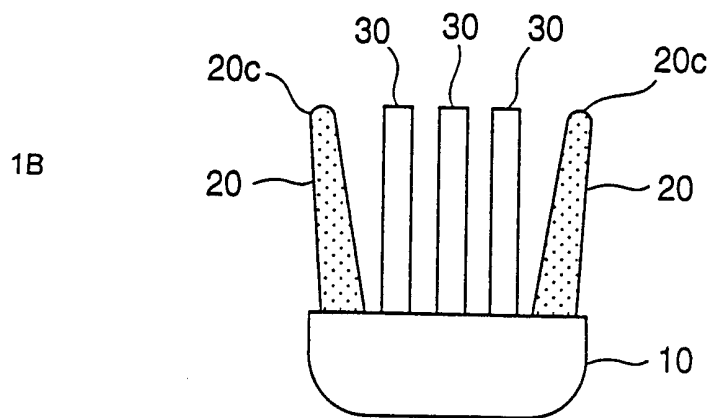
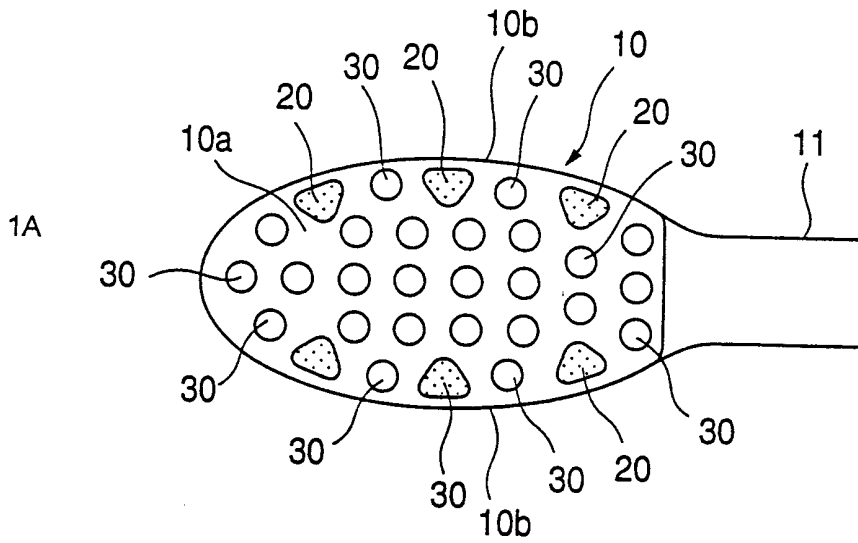

Fig. 2

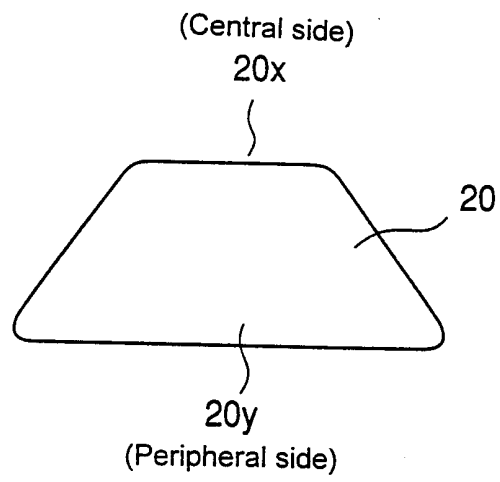

Fig. 3

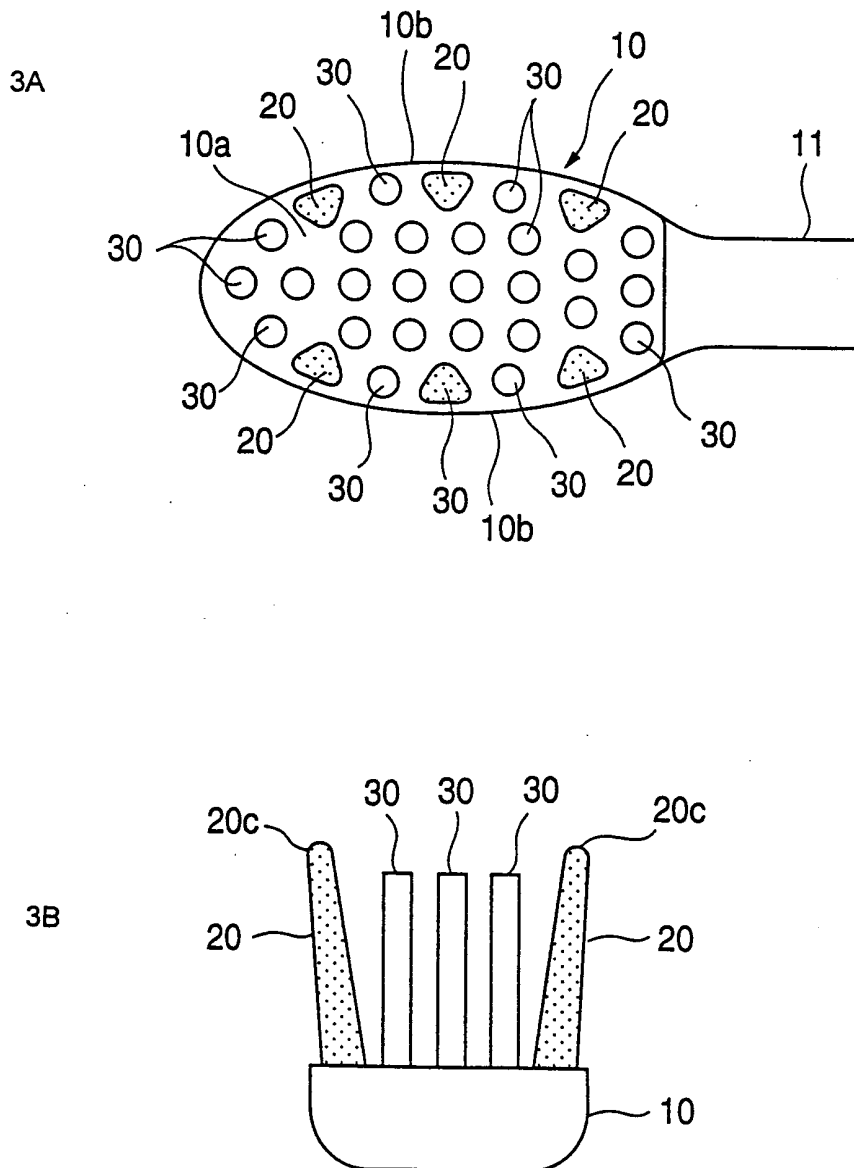

Fig. 4

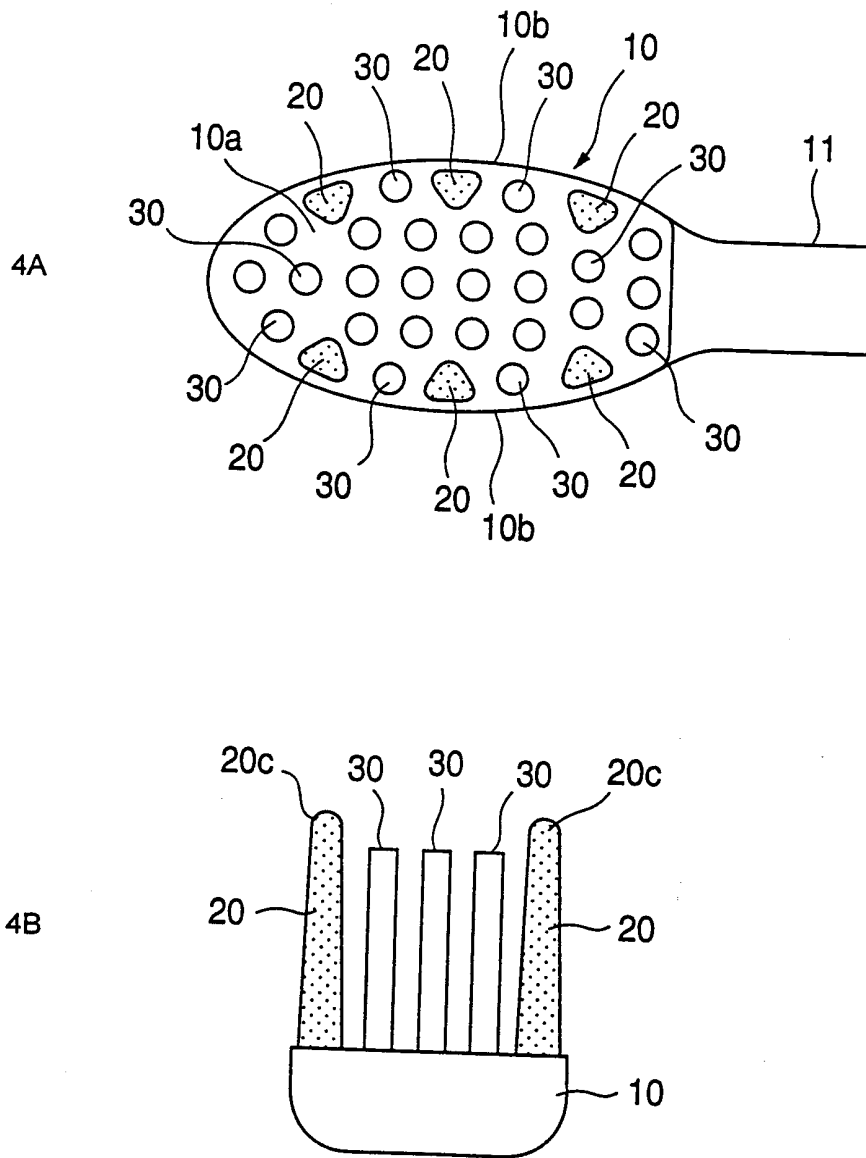

Fig. 5

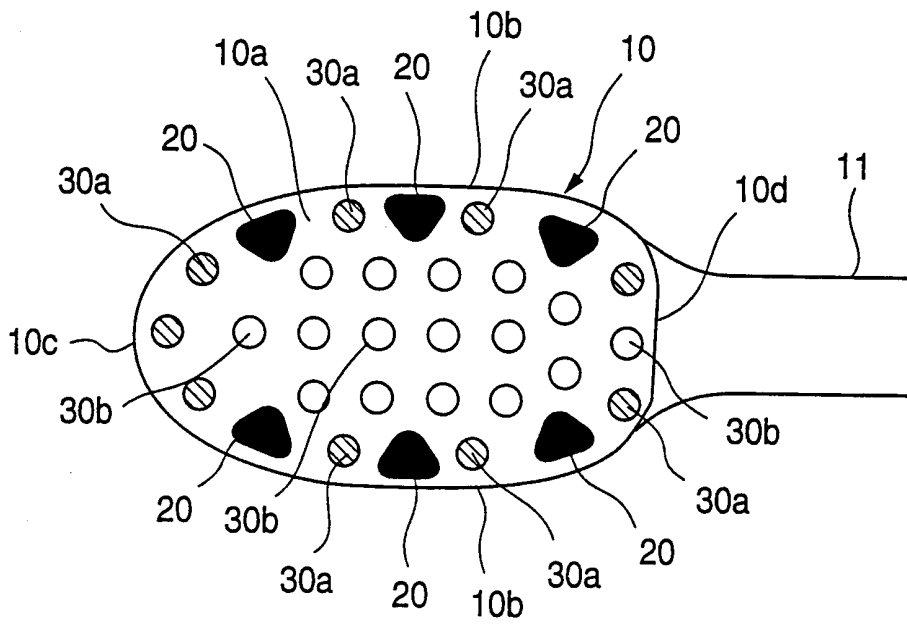

Fig. 6

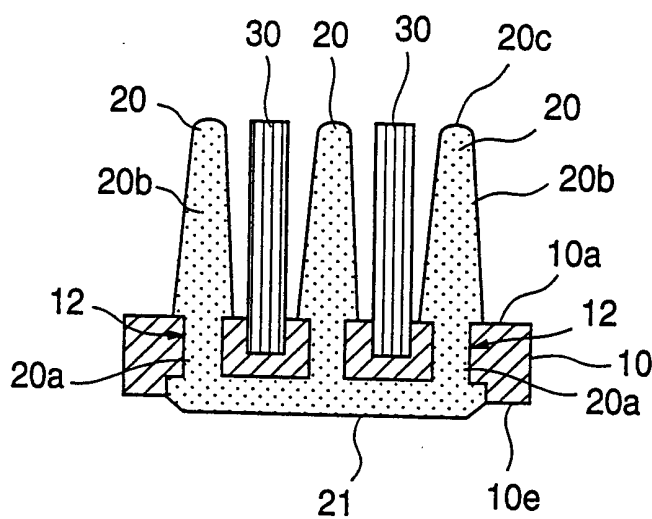
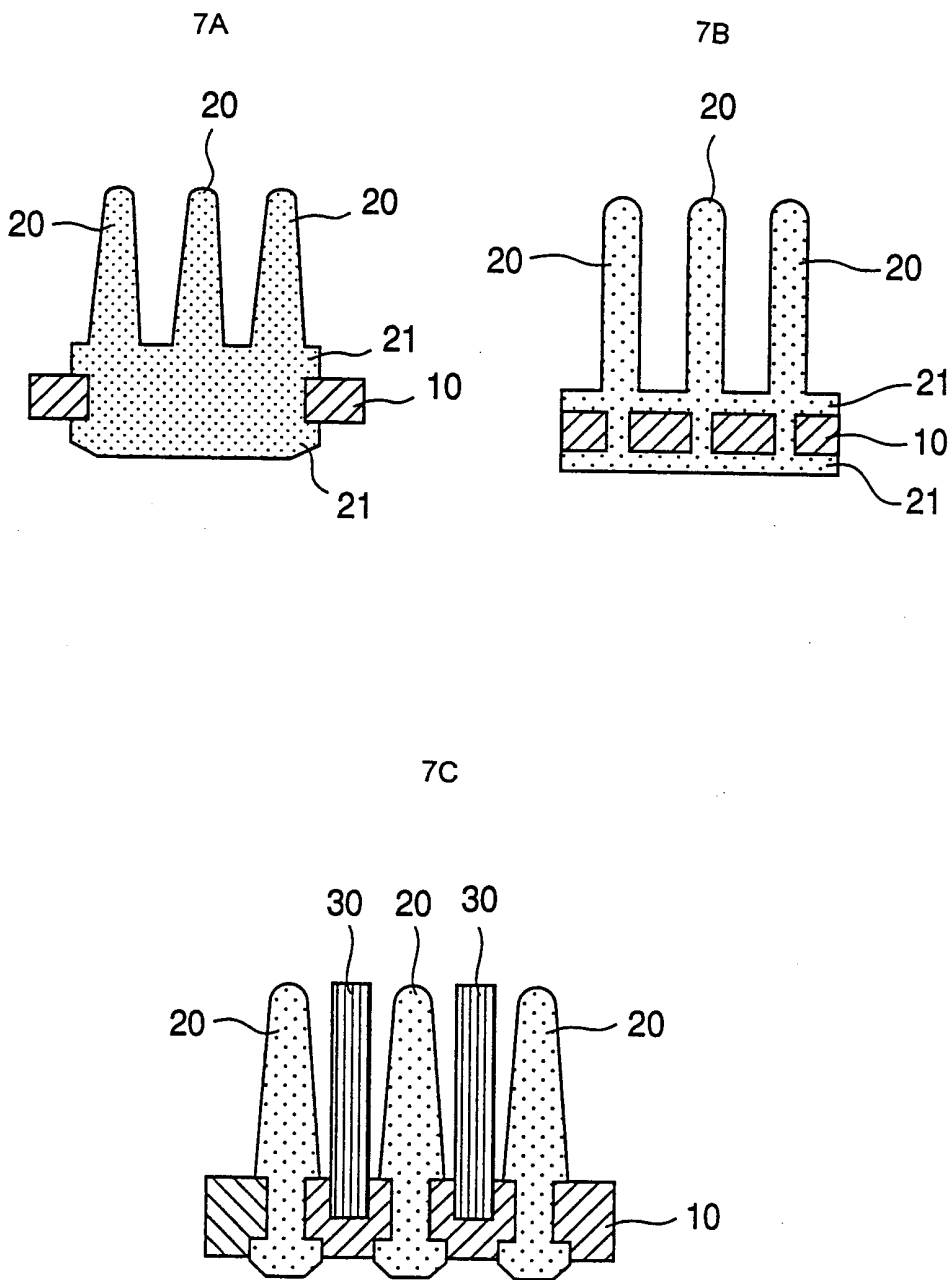

Fig. 7



INTERNATIONAL SEARCH REPORT

International Application No.
PCT/JP 00/01737

A. CLASSIFICATION OF SUBJECT MATTER
IPC 7 A46B9/06 A46B15/00

According to International Patent Classification (IPC) or to both national classification and IPC

B. FIELDS SEARCHED

Minimum documentation searched (classification system followed by classification symbols)
IPC 7 A46B

Documentation searched other than minimum documentation to the extent that such documents are included in the fields searched

Electronic data base consulted during the international search (name of data base and, where practical, search terms used)

EPO-Internal

C. DOCUMENTS CONSIDERED TO BE RELEVANT

Category °	Citation of document, with indication, where appropriate, of the relevant passages	Relevant to claim No.
A	US 2 042 239 A (PLANDING) 26 May 1936 (1936-05-26) page 1, right-hand column, line 13 -page 1, left-hand column, line 17; figures -----	1-10
A	US 1 924 152 A (CONEY) 29 August 1933 (1933-08-29) page 1, line 43 -page 2, line 41; figures -----	1-10
P,A	FR 2 773 962 A (SYNTHELABO) 30 July 1999 (1999-07-30) page 4, line 8 -page 9, line 15; figures -----	1-10

Further documents are listed in the continuation of box C.

Patent family members are listed in annex.

° Special categories of cited documents :

- "A" document defining the general state of the art which is not considered to be of particular relevance
- "E" earlier document but published on or after the international filing date
- "L" document which may throw doubts on priority claim(s) or which is cited to establish the publication date of another citation or other special reason (as specified)
- "O" document referring to an oral disclosure, use, exhibition or other means
- "P" document published prior to the international filing date but later than the priority date claimed

- "T" later document published after the international filing date or priority date and not in conflict with the application but cited to understand the principle or theory underlying the invention
- "X" document of particular relevance; the claimed invention cannot be considered novel or cannot be considered to involve an inventive step when the document is taken alone
- "Y" document of particular relevance; the claimed invention cannot be considered to involve an inventive step when the document is combined with one or more other such documents, such combination being obvious to a person skilled in the art.
- "&" document member of the same patent family

Date of the actual completion of the international search

28 June 2000

Date of mailing of the international search report

06/07/2000

Name and mailing address of the ISA

European Patent Office, P.B. 5818 Patentlaan 2
NL - 2280 HV Rijswijk
Tel. (+31-70) 340-2040, Tx. 31 651 epo nl,
Fax: (+31-70) 340-3016

Authorized officer

Triantaphillou, P

INTERNATIONAL SEARCH REPORT

Information on patent family members

International Application No

PCT/JP 00/01737

Patent document cited in search report	Publication date	Patent family member(s)	Publication date
US 2042239 A	26-05-1936	NONE	
US 1924152 A	29-08-1933	BE 396960 A FR 757031 A GB 395624 A	18-12-1933
FR 2773962 A	30-07-1999	AU 2061499 A WO 9937181 A	09-08-1999 29-07-1999