

(19)
(12)

(KR)
(Y1)

(51) 。 Int. Cl. ⁷
F16H 57/02

(45)
(11)
(24)

2001 10 12
20 - 0240669
2001 07 19

(21) 20 - 2001 - 0012140
(22) 2001 04 26

(73) 1

(72)

(74)

:
가 :

(54)

가 , 가

(13) (14)가 1 (15) (12) 2 (13) (16) (17, 17') (18) (14') (21) (25, 26) 1 (12) 2 (21)

가 가 가

3

, , , ,

1 ;

2 ;

3 ;

4 .

1: 2: 3: 12, 13: 14:
 15: 16: 17, 17 : 19:

(Ball Bearing)

가

1 (1) (2), (3) (1) (3)
 (4), (5) (1) (2) (6)
 (Coupling) (7)

(1) (2), (3) 가 (7)

ring) (8, 9, 10, 11)

(7) (6)가

(Shaft Bea

가

2 , 1 (Flange)
 2 가 1 2 , 1 2 (Shaft)
 , 가

2 가가

2 , 3

2 , 가 3 (18) , 1 (12) 2 (13) (18) 가
 , 가 (15) (16)

(1) 1 (12) 2 (13) (1) (22) (2) (23) ,
 (2) (12, 13) (18) (15) (1)
 5) (20) (21) (14) 가 (14) , (1)
 17, 17) (1) (2) (21) (

가 2 (19) , (19)
 가 (21) (20)

4

4 (15) (1) (2),
 (2) (3) (12, 13) (3)가 (20)
 (18) 가 (15) (20)
 (25, 26) (15) (21) (14)
 가 (14)가 (12, 13)
 (25, 26) (8, 9, 10, 1
 1)

가

가 .

가 ,

(57)

1.

1 (12) 2 (13) ;

1 (12) 2 (13) (18) ,
(15) ;

(15) (14) (21) 1 (12) 2 (13)
(14) ;

(14) 1 (12) 2 (13)
(17, 17) .

2.

1 ,

(15) (19) , (19) 가
(21) (20)

1

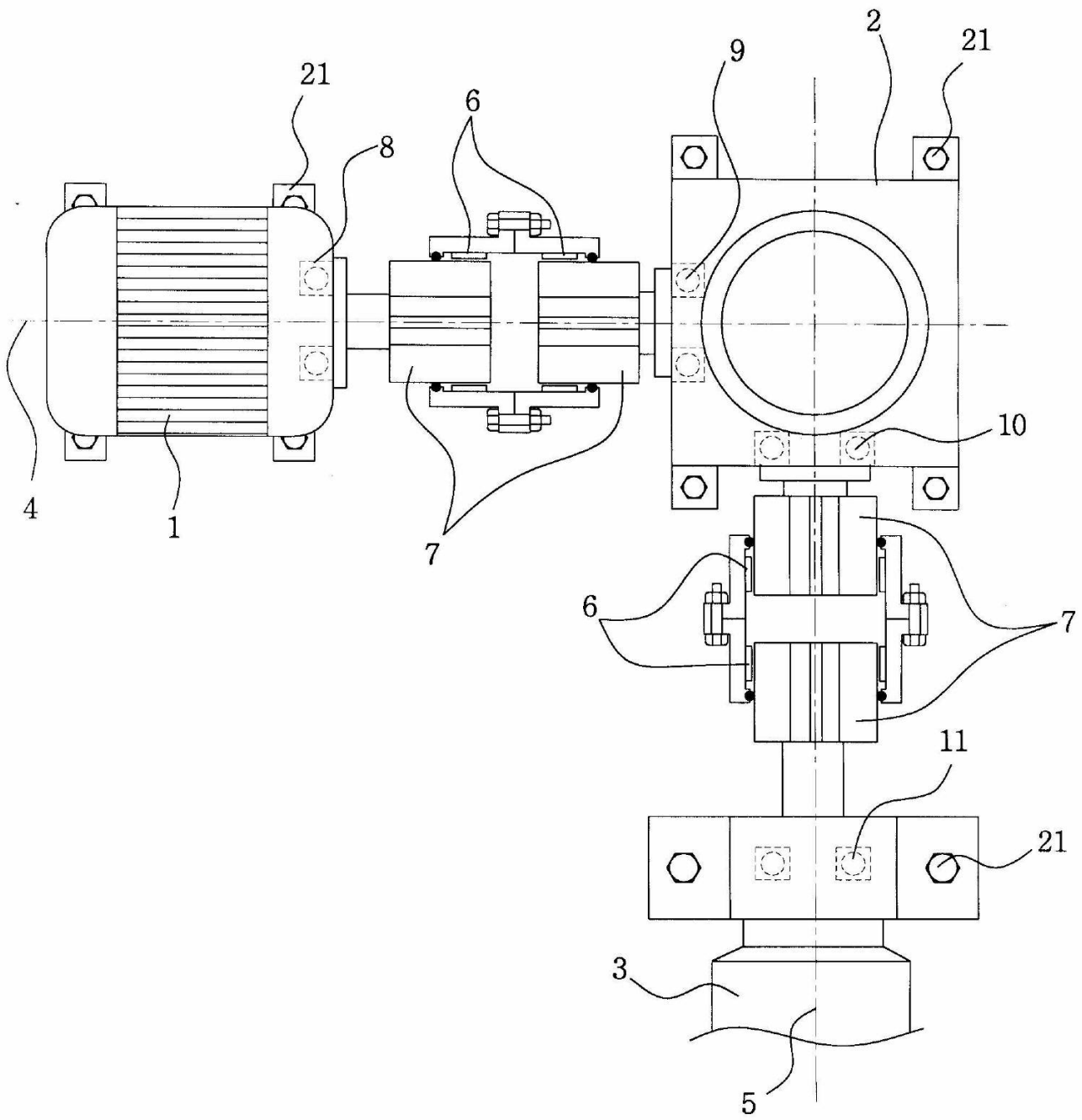

2

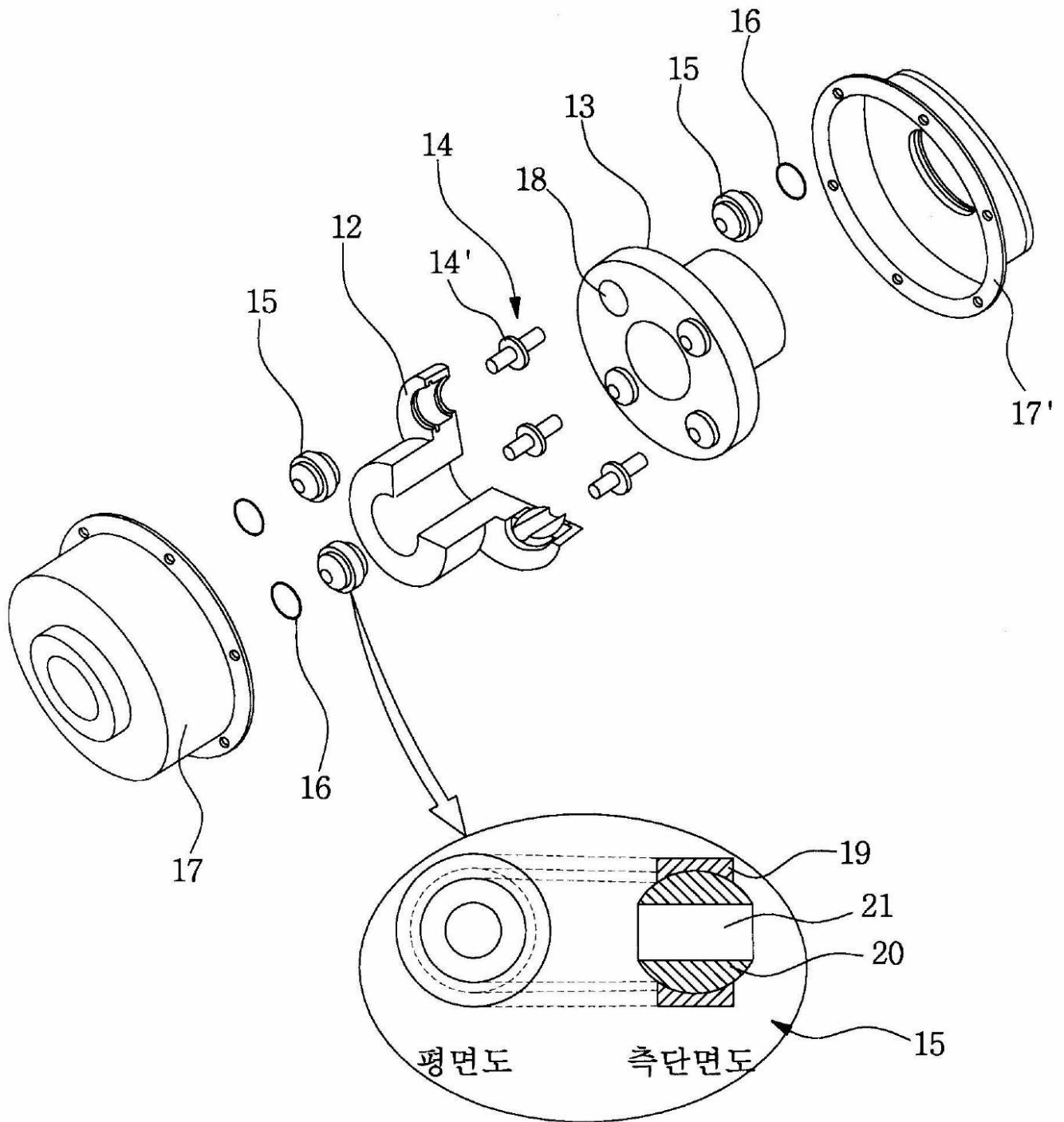

3

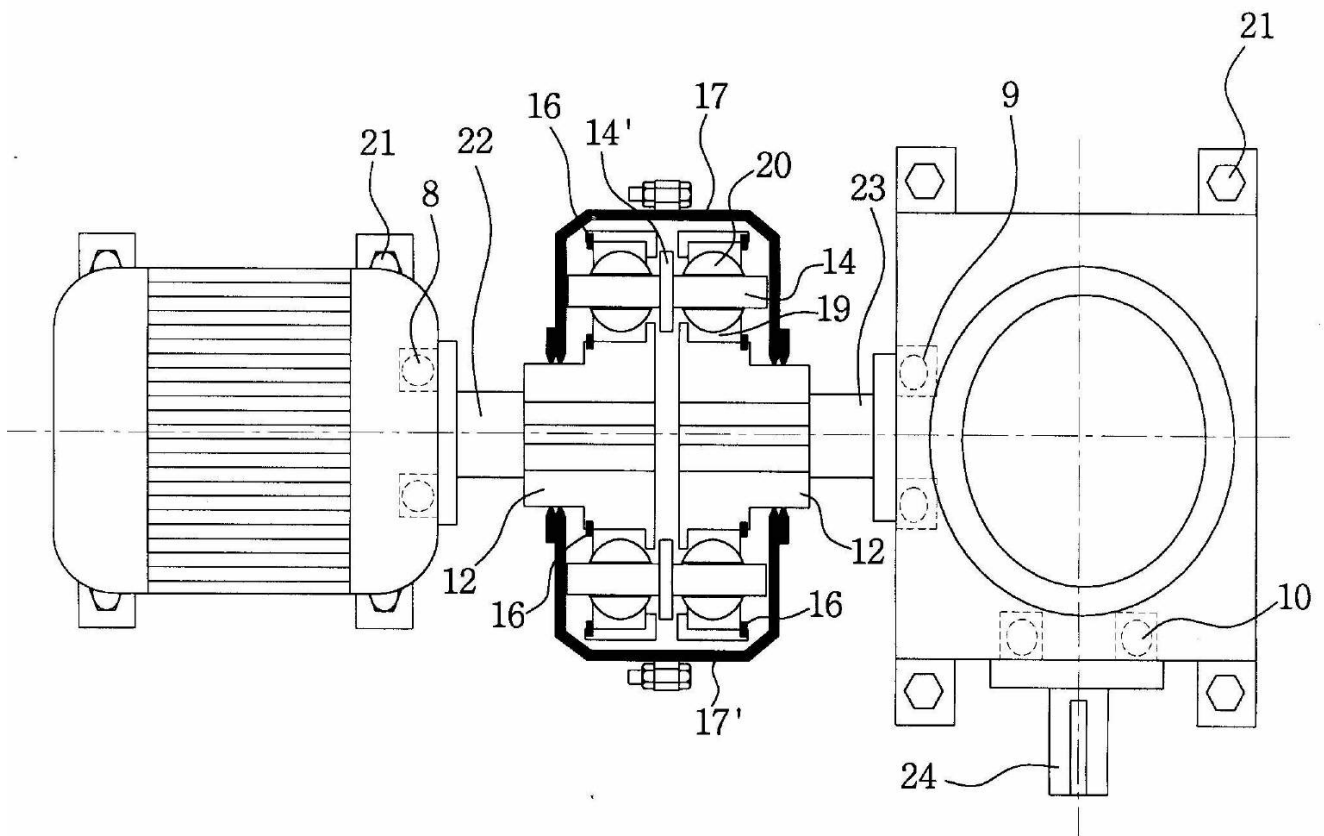

4

