

(12) UK Patent Application (19) GB (11) 2 321 725 (13) A

(43) Date of A Publication 05.08.1998

(21) Application No 9701882.4

(22) Date of Filing 30.01.1997

(71) Applicant(s)  
**Motorola Inc**  
(Incorporated in USA - Illinois)  
1303 East Algonquin Road, Schaumburg,  
Illinois 60196, United States of America

(72) Inventor(s)  
**Michael John Hill**

(74) Agent and/or Address for Service  
**Sarah J Spaulding**  
Motorola Limited, European Intellectual Property  
Operation, Midpoint, Alencon Link, BASINGSTOKE,  
Hampshire, RG21 7PL, United Kingdom

(51) INT CL<sup>6</sup>  
G05F 1/46 , G06K 19/07

(52) UK CL (Edition P )  
G3U UAE9 U207 U208

(56) Documents Cited  
WO 89/07295 A1

(58) Field of Search  
UK CL (Edition O ) G3U UAE9 UAX , H4L LAPS  
INT CL<sup>6</sup> G05F , G06K

(54) Abstract Title

**Apparatus and method for dissipating excess power received by a contactless portable data carrier**

(57) A portable data carrier includes a receiving circuit 202 for use thereby in a contactless mode to receive a power signal. The portable data carrier further includes a rectifying element 206 connected to the receiving circuit and having two voltage outputs, whereby the difference between the two voltage outputs reflects an amplitude of the power signal. A comparator element determines the difference between the two voltage outputs and generates a control signal 210 whose amplitude varies substantially proportionately to the difference between the two voltages. Switchable resistive elements  $R_{D1}, R_{D2}$  are manipulated by the control signal, to thereby effect power dissipation, as necessary during periods of excess power reception.

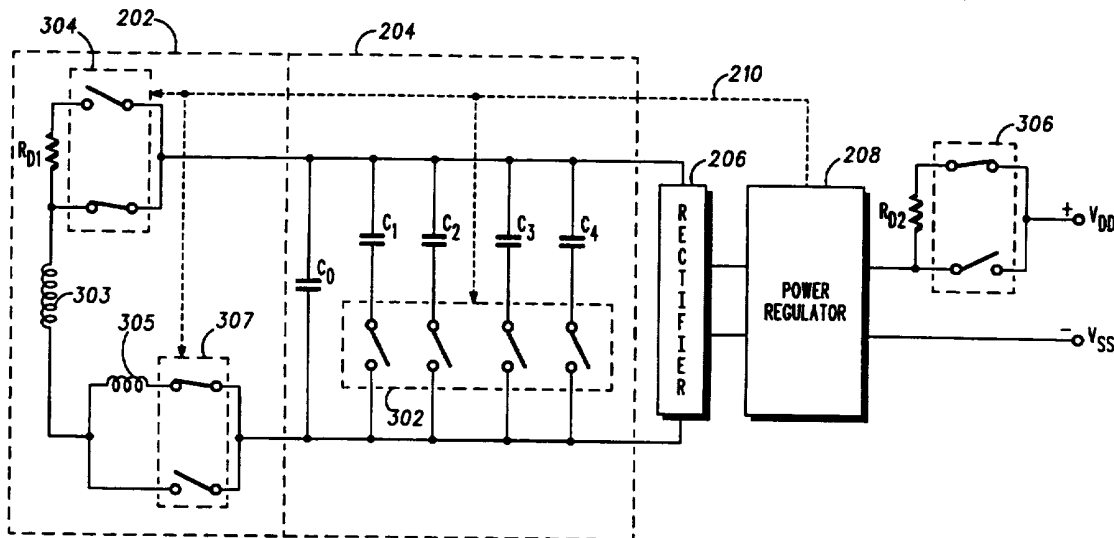
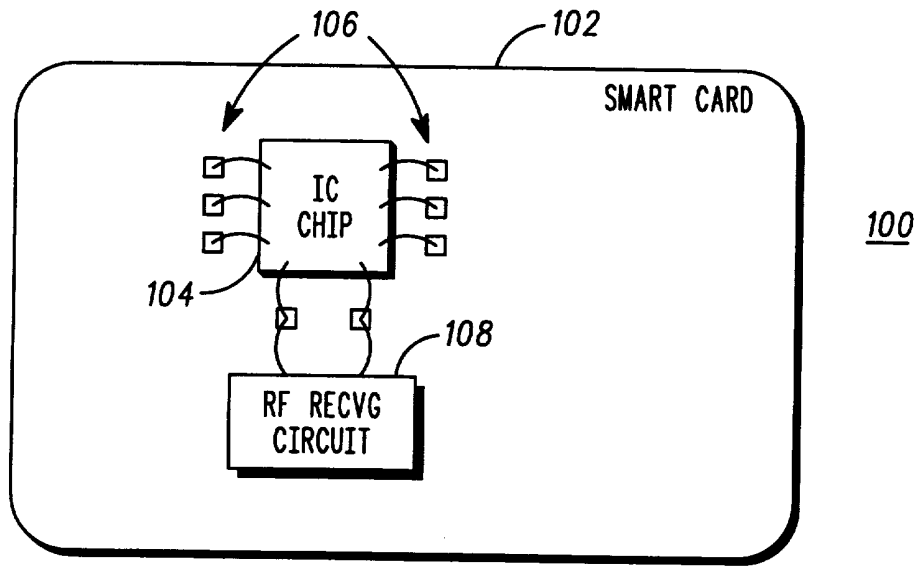

FIG. 3

At least one drawing originally filed was informal and the print reproduced here is taken from a later filed formal copy.

This print takes account of replacement documents submitted after the date of filing to enable the application to comply with the formal requirements of the Patents Rules 1995

GB 2 321 725 A



**FIG. 1**

—PRIOR ART—

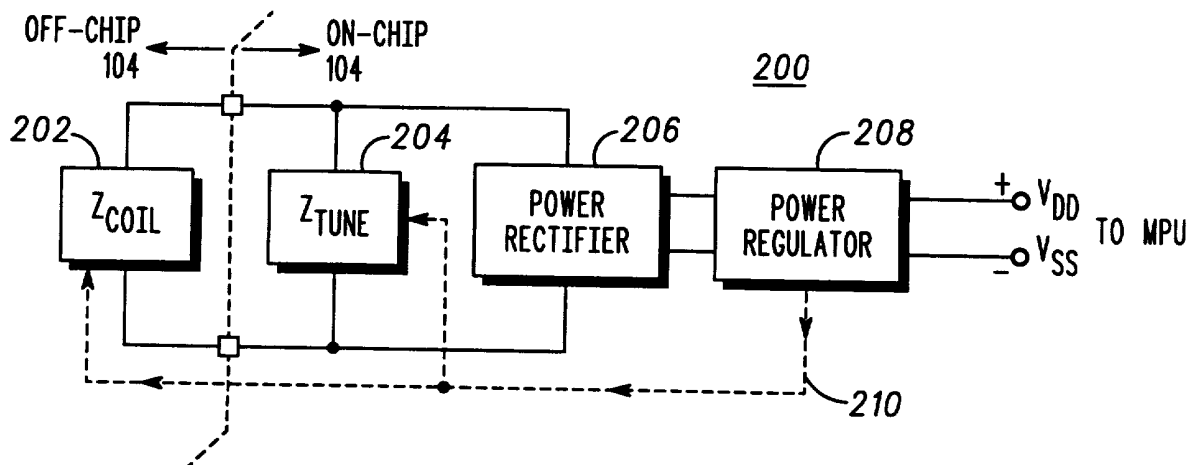

**FIG. 2**

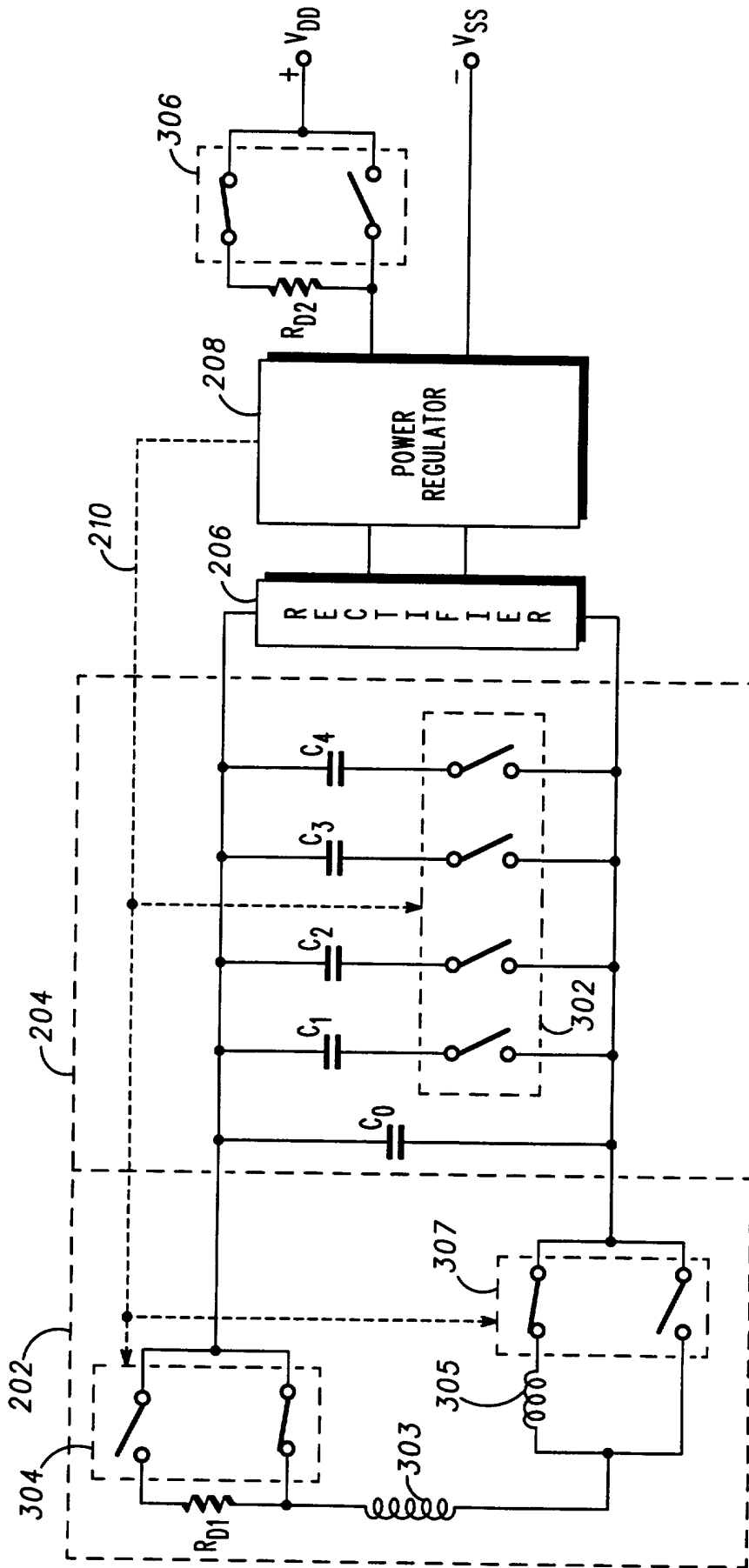

FIG. 3

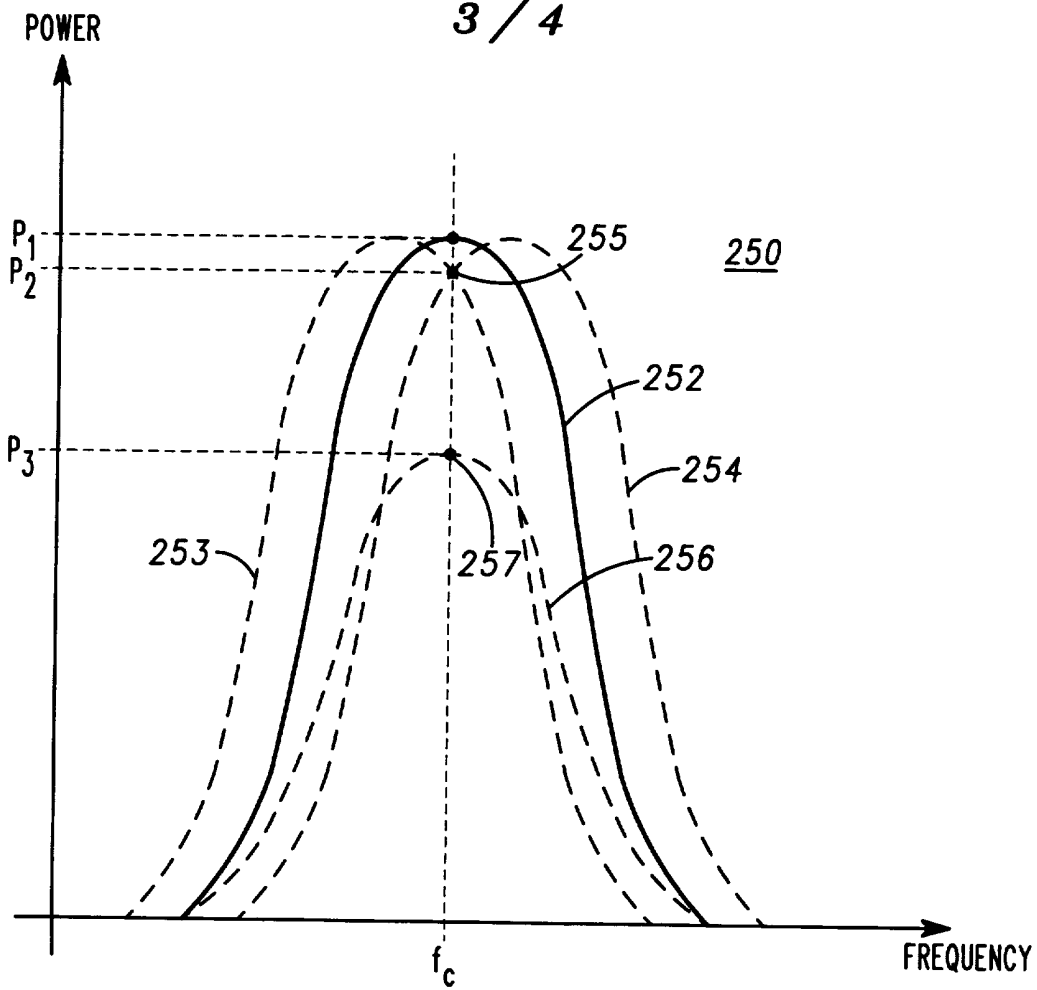

FIG. 2A

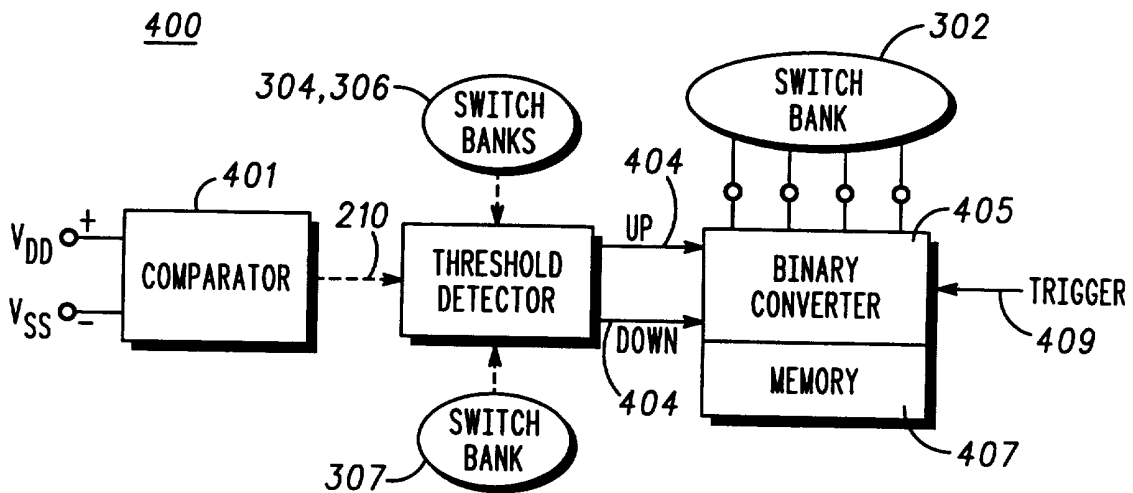

FIG. 4

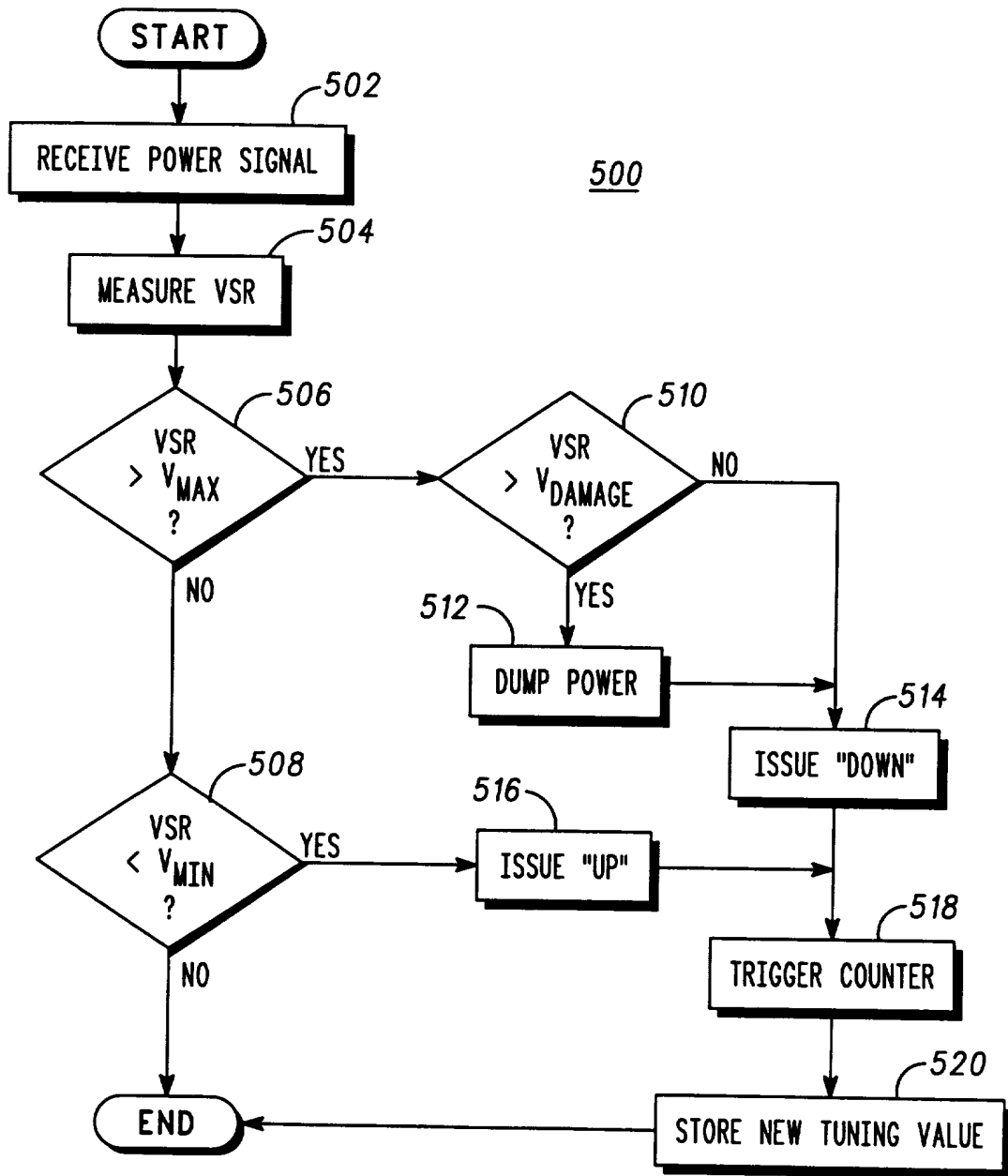

FIG. 5

**APPARATUS AND METHOD FOR DISSIPATING EXCESS  
POWER RECEIVED BY A CONTACTLESS PORTABLE DATA CARRIER**

5                                    Field of the Invention

The present invention relates generally to a portable data carrier designed for use in a contactless mode, and in particular to a method and apparatus for regulating power delivered to such a portable data carrier.  
10

Background of the Invention

15            Portable data carriers (e.g., smart cards or chip cards) are known to include a plastic substrate within which a semiconductor device (i.e., integrated circuit--IC) is disposed for retaining digital data. This digital data may constitute program instructions, user information, or any combination thereof. Moreover, these chip cards are known to be operational in a contacted mode, whereby an array of contact points disposed on the plastic substrate and interconnected with the semiconductor device is used to exchange electrical signals between the chip card and an  
20            external card reader, or terminal. Similarly, there exists smart cards that operate in a contactless mode, whereby a radio frequency (RF) receiving circuit is employed to exchange data between the card and a card terminal. That is, the card need not come into physical contact with the card  
25            terminal in order to exchange data therewith, but rather must simply be placed within a predetermined range of the terminal.  
30

35            Additionally, there exist smart cards that are alternatively operational in either a contacted mode or a contactless mode. Such cards are equipped with both RF

receiving circuitry (for contactless operations) as well as an array of contact pads (for contacted operations). These cards are commonly referred to as combination chip cards, or combi-cards. It should be noted that in both the contacted  
5 chip card and the combi-card arrangements, the array of contact pads typically conform to the ISO Standard 7816, which standard is incorporated herein by reference.

One of the problems of contactless smart card  
10 applications stems from irregular power reception by the smart card. Excessive power levels, inadequate power levels, or simply power levels varying greatly over time, each pose unique problems for the smart card processing unit. By way of example, excessive power levels delivered to a smart card  
15 can result in undesirable heat build up or may even damage the internal circuitry inside the plastic laminate. By contrast, inadequate power levels may result in erroneous data being transferred, or may even compromise the security of the data stored on the smart card.

20 Accordingly, there exists a need for a smart card apparatus and method for regulating power delivered to the card over a wide range of applications. Moreover, a power regulator and method therefore that was automatically  
25 adaptive, allowing for tuning the electrical characteristics to optimize power reception during the life of the smart card, and which accounted for both excessive and inadequate power levels thereafter, would be an improvement over the prior art.

30

#### Brief Description of the Drawings.

FIG. 1 shows a portable data carrier arrangement that can be  
35 used in a contactless mode, according to the invention;

FIG. 2 shows a simplified block diagram of a portion of the contactless portable data carrier shown in FIG. 1;

5 FIG. 2A shows a power curve responsive to several embodiments of the present invention;

FIG. 3 shows a more detailed schematic diagram of the block diagram of FIG. 2;

10 FIG. 4 shows a simplified block diagram of the switch select logic shown in FIG. 3; and

15 FIG. 5 shows a flow diagram depicting operation of the power regulation scheme, in accordance with the present invention.

#### Detailed Description of a Preferred Embodiment.

20 The present invention encompasses a portable data carrier that is used in a contactless mode and receives a power signal from an external reader/terminal. After receipt of the power signal by a radio frequency (RF) receiving circuit, the power signal is rectified, thereby producing a voltage output reflecting an amplitude of the received power  
25 signal. A comparator is then used to determine the voltage output, which comparator generates a control signal whose amplitude varies substantially proportionally to the power level presented thereat. The control signal is operably coupled to a plurality switchable impedances disposed  
30 substantially on the portable data carrier to dynamically alter the electrical characteristics thereof.

The present invention can be best described using the illustrations set forth in FIGS. 1-5. FIG. 1 shows a  
35 combination smart card 100, in accordance with the present invention. Such smart cards are conventionally manufactured



using a plastic substrate 102 having disposed therein an integrated circuit 104, as shown. Electrically connected to the integrated circuit 104 is a plurality of contact pads 106, which typically conform to the International Standard (ISO 5 7816). A radio frequency (RF) receiving circuit 108 is used to gather RF signals emitted for use by the combination smart card 100. In it's simplest form, the RF receiving circuit 108 may comprise an antenna disposed peripherally about the plastic substrate 102. This RF receiving circuit is 10 used to receive, inter alia, a power signal for use by the smart card during operation.

FIG. 2 shows a simplified block diagram of a power regulating portion of the smart card 100, in accordance with 15 a preferred embodiment of the invention. Coil impedance 202 represents the discrete components associated with the RF receiving circuit 108 shown in FIG. 1. It should be noted that this impedance, in accordance with a preferred embodiment, is located "off-chip", as denoted in FIG. 2. Coil impedance 20 202 is further manipulated using a portion of control signal 210, as shown and later described. Tuning impedance 204 is similarly controlled by a portion of control signal 210, as later described, and is located "on-chip." A power rectifier 206 is disposed between the tuning impedance 204 and a 25 power regulator 208. It is the power regulator 208 that generates the control signal 210, which is in turn used to modify the coil impedance 202 and the tuning impedance 204, in accordance with the present invention. Voltages VDD and VSS are presented to the processing unit (MPU) for the 30 smart card 100 shown in FIG. 1. According to a preferred embodiment, this processing unit is also "on-chip."

FIG. 2A shows a set of power curves 250 that illustrate the effects of power regulation and dissipation, according to 35 several embodiments of the invention. As shown, power curve 252 represents the power response of the RF receiving

circuit, tuned to be at optimum power reception,  $P_1$ , at the carrier frequency,  $f_c$ . According to the invention, the power response characteristic 252 is altered by switching impedances into the resonant receiving circuit, as later  
5 described with reference to FIG. 3. In particular, selectively adding reactive components to the receiving circuit has the effect of de-tuning (if less power is desired, or tuning (when more power is desired) as illustrated by power curves 253, 254. That is, by adding series inductance or parallel  
10 capacitance to the resonant circuit, the power response curve is shifted to the left (see curve 253). Similarly, by reducing series inductance or parallel capacitance in the resonant circuit, the power response curve is shifted to the right (see curve 254). In both cases, the apparent power seen by the  
15 smart card processor at the carrier frequency is lowered to a power level,  $P_2$ , at point 255 on both power response curves, as shown. As can be appreciated by those skilled in the art, this technique of tuning and de-tuning the RF receiving circuit can be advantageously employed to selectively affect  
20 power regulation, and thereby control how much power is seen by the processing element of the smart card.

Power dissipation is accomplished in a similar manner, except the switchable impedances are substantially resistive  
25 (i.e., causing nearly zero frequency shift). By selectively switching resistive elements, as described with reference to FIG. 3 below, the power seen by the processor is reduced to a power level,  $P_3$ , as indicated on power curve 256 at point 257. In this manner, excess power received by the RF  
30 receiving circuit can be dissipated across the resistive components, as next described.

FIG. 3 shows a more detailed schematic diagram of a power regulating assembly, in accordance with the present  
35 invention. In particular, it is shown that the tuning impedance 204 is comprised of a plurality of shunt

capacitors  $C_0$ - $C_4$ , and a switch bank 302. (It should be noted that the present invention could well be designed using series inductances, but the shunt capacitors is presently preferred). Switch bank 302 is controlled by a portion of the control signal 210, and is operative to selectively activate shunt capacitors  $C_1$  -  $C_4$ , as shown. Similarly, coil impedance 202 is comprised of an inductor 303, a dissipating resistor  $R_{D1}$  and a series inductor 305, which latter two components are selectively to switched, using switch banks 304 and 307, respectively. Switch bank 304 is controlled by a second portion of the control signal 210, and switch bank 307, is controlled by a third portion of the control signal 210. According to the invention, the second portion of the control signal 210 is used to selectively place the dissipating resistor  $R_{D1}$  in series with the inductor 303. A fourth portion of the control signal 210 is used to selectively enable a second dissipating resistor,  $R_{D2}$ , using a third switch bank 306 (not shown in FIG. 2). It should be noted that  $R_{D2}$  functions in much the same way as  $R_{D1}$ , i.e., to divert undesired energy away from the sensitive circuitry of the smart card 100.

As earlier stated, one of the problems of contactless smart card operations rise in the varying tolerances seen by the card during use. For example when a contactless smart card is presented one centimeter (1 cm) away from the card terminal, that card receives considerably more power than the same card presented, e.g., 9 cm from the card terminal. Under these conditions, it would be beneficial to somehow either reduce the amount of power level seen by the smart card circuitry or dissipate the excess energy in a non-detrimental fashion. The present invention anticipates both of these solutions using a plurality of switchable impedances to reduce the amount of power levels seen by the smart card or to divert excess energy that would otherwise build up and damage the sensitive circuitry on-board the smart card.

According to the invention, the power regulating circuitry reduces the apparent power delivered to the smart card circuitry by effectively detuning the power receiving circuitry. In particular, detuning of the resonant circuit (which comprises an inductor 303, a total capacitance--i.e.,  $C_T$  being the sum of  $C_0$ - $C_4$ --and an inherent resistance) is accomplished by selectively activating shunt capacitors  $C_1$  -  $C_4$ . That is, by selectively engaging capacitors  $C_1$  -  $C_4$ , the total shunt capacitance  $C_T$  is progressively increased until the receiving circuit is sufficiently detuned, thereby reducing the effective power levels seen by the card. In a similar manner, the smart card 100 can be dynamically tuned using the same approach by slightly adjusting the total capacitance  $C_T$  using the switch bank 302. Thus, the apparent power level received by the card can be adjusted (up or down) by tuning or detuning the receiving circuit using control signal 210 and switch bank 302.

According to a preferred embodiment, shunt capacitors  $C_1$  -  $C_n$  can be chosen such that a total shunt capacitance,  $C_T$ , is given by the equation:

$$C_T = (C_0 + \sum(C_1^{2n}))$$

In this manner,  $C_T$  can be binarily changed from a nominal  $C_0$  value, in either an ascending or descending sequence. This allows for either gross changes (e.g., for quickly de-tuning the resonant circuit, and therefor limiting power reception) or minor changes (e.g., for fine-tuning the resonant circuit to optimize power reception). It should be noted that the switching of multiple series inductances (for de-tuning) or multiple series resistors (for power dissipation) can also be accomplished using multiple switches, as described above for use with capacitors  $C_1$ - $C_4$ .

In this manner, finer resolution can be obtained with inductive and resistive elements as well.

Using a different approach, selectively disposed  
5 dissipating resistors RD1, RD2 can be used to dissipate  
excessive power received by the smart card. As earlier  
noted, switch banks 304 and 306 can be selectively activated  
to place these dissipating resistors in series, thereby  
resulting in effective power dissipation. Of course, these  
10 dissipating resistors will heat up, but so long as these  
resistive elements are disposed "off-chip," the internal (i.e.,  
on-chip) smart card circuitry will not be damaged. It is  
noted that the resistive element, according to the invention,  
may be any combination of externally deposited resistors  
15 (e.g., off-chip resistive paste), resistive connections (e.g., by  
using off-chip lossy conductive epoxy), or series resistances  
disposed on-chip. Thus, it can be seen that the problem of  
excess power can be managed according to the invention in  
one of three ways:  
20 1) by effectively de-tuning the resonant circuit, to  
thereby reduce the effective power level seen by the  
power rectifier;  
2) by dissipating the excess power using a series of  
dissipating resistors; or  
25 3) a combination of the above techniques.

Moreover, having a tuning capability provides the  
further benefit of being able to dynamically tune the resonant  
circuit, so that power reception can be optimized. This last  
30 feature is particularly beneficial when compensating for  
electronic parts on a smart card having electrical  
characteristics that change over extended periods of time  
(commonly referred to as "aging").

35 FIG. 4 shows a simplified block diagram 400 depicting  
how the control signal 210 is used by switch banks 302, 304,

306. As mentioned earlier, a comparator 401 is used to determine a voltage difference between  $V_{DD}$  and  $V_{SS}$ . A control signal 210 is generated thereby, which signal is substantially proportional to the measured voltage difference. Control signals 210" and 210'" are used to dump power into the dissipating resistors, using switch banks 304 and 306, as earlier described. Control signal 210' is inputted to a threshold detector 403, which determines whether or not the voltage difference is within an acceptable range (i.e., between  $V_{min}$  and  $V_{max}$ ). Depending on whether or not the voltage difference is within range, the threshold detector 403 generates directional tuning signals 404 (designated "up" and "down"). According to the invention, a "down" signal is generated when the power level is above  $V_{max}$ , and an "up" signal is generated when the power level is below  $V_{min}$ .

The directional tuning signals are then inputted to a binary counter 405 that carries a counter value for controlling switch bank 302. It should be noted that the counter value can be periodically stored in memory 407 (in a preferred embodiment, this would be a non-volatile memory so that the latest tuning value can be retrieved at any time and provided to the switch bank 302). The binary counter value is presented to the switchbank 302 upon receipt of the triggering signal 409, which implementation will be appreciated by those skilled in the art.

FIG. 5 shows a flow diagram 500 depicting the operation of the power regulating circuitry of the smart card, in accordance with the present invention. Upon receipt (502) of a power signal, the shunt regulator voltage (VSR) is measured (504) using the comparator 401 shown in FIG. 4. A decision (506) is then reached to determine whether or not the VSR is greater than  $V_{max}$ . If not, a decision (508) is reached to determine whether or not VSR is less than  $V_{min}$ .

(It should be noted that decisions 506, 508 constitute the functionality of threshold detector 403 shown in FIG. 4.)

5 If the VSR is greater than  $V_{max}$ , another decision (510) is reached, whereby it is determined whether or not VSR is greater than a voltage,  $V_{damage}$ , that may be detrimental to the internal circuitry. If so, power is dumped (512) into dissipating resistors  $R_{D1}$  or  $R_{D2}$ , as shown in FIG. 3. At this point, a "down" signal is issued (514) by the threshold  
10 detector. Similarly, if the VSR is less than  $V_{min}$  (indicating inadequate power level for proper operation of the card), an "up" signal is issued (516) by the threshold detector. The binary counter 405 is then triggered (518), thereby updating the counter values according to the inputted  
15 directional tuning signals, and presenting it to switch bank 302 shown in FIG. 4. According to the invention, this new tuning value is also stored (520) in memory element 407 shown in FIG. 4, before the routine is exited.

20 In the foregoing manner, the present invention advantageously provides for the effective reduction and or dissipation of excess power seen by the smart card. Further, the resonant tuning circuit can be selectively fine-tuned to improve power receiving performance during the operational  
25 life of the smart card.

What is claimed is:

## Claims

1. A portable data carrier having a processing element that includes a receiving circuit for use thereby in a contactless mode to receive a power signal, the portable data carrier comprising:
- 5
- a rectifying element operably coupled to the receiving circuit having two voltage outputs, a difference between the two voltage outputs reflecting an amplitude of the power signal;
- 10
- a comparator element operably coupled to the rectifying element to determine said difference between the two voltage outputs, the comparator element having an output that carries a control signal whose amplitude varies substantially proportionately to said difference between the two voltage outputs; and
- 15
- a switchable resistive element, disposed substantially apart from the processing element and operably coupled to the control signal.
- 20
2. The portable data carrier of claim 1, wherein the switchable resistive element comprises a resistive material located substantially apart from the processing element.
- 25
3. The portable data carrier of claim 2, wherein the switchable resistive element further comprises a switch operably coupled to receive said control signal.
- 30
4. The portable data carrier of claim 3, wherein the switch is disposed substantially within the processing element.
- 35
5. The portable data carrier of claim 3, wherein the switch is disposed substantially apart from the processing element.



6. In a portable data carrier that includes a radio frequency (RF) receiving circuit for use thereby in a contactless mode to receive a power signal, the portable data carrier further including a processing element, a method of dissipating  
5 excess power delivered to the processing element, the method comprising the steps of:

receiving the power signal;

10 determining the input power level based on the power signal;

providing a switchable resistive element; and

15 selectively activating, responsive to the step of determining the input power level, the switchable resistive element, thereby dissipating excess power level delivered to the processing element.

20 7. The method of claim 6, wherein the step of determining the input power level comprises the step of measuring a voltage difference between a pair of output nodes on a rectifying element that is operably coupled to the RF receiving circuit.

25 8. The method of claim 6, wherein the resistive element comprises a plurality of resistors disposed substantially apart from the processing element, and wherein the step of selectively activating comprises the steps of:

30 determining which of the plurality of resistors are required to dissipate the excess power delivered to the processing element; and

35 individually switching, responsive to the step of determining the plurality of resistors based on the counter value.



Application No: GB 9701882.4  
Claims searched: 1 to 8

Examiner: Mr A Oldershaw  
Date of search: 21 April 1997

**Patents Act 1977**  
**Search Report under Section 17**

**Databases searched:**

UK Patent Office collections, including GB, EP, WO & US patent specifications, in:  
UK CI (Ed.O): G3U UAE9, UAX; H4L LAPS  
Int CI (Ed.6): G05F; G06K  
Other:

**Documents considered to be relevant:**

Category	Identity of document and relevant passage	Relevant to claims
X	WO89/07295 (MAGELLAN CORPORATION)	1,6 at least

X	Document indicating lack of novelty or inventive step	A	Document indicating technological background and/or state of the art.
Y	Document indicating lack of inventive step if combined with one or more other documents of same category.	P	Document published on or after the declared priority date but before the filing date of this invention.
&	Member of the same patent family	E	Patent document published on or after, but with priority date earlier than, the filing date of this application.

13