



US 20030208257A1

(19) **United States**

(12) **Patent Application Publication**
Holman et al.

(10) **Pub. No.: US 2003/0208257 A1**

(43) **Pub. Date: Nov. 6, 2003**

(54) **ENDOVASCULAR APPARATUS**

(76) Inventors: **Thomas J. Holman**, Minneapolis, MN (US); **Darlene A. Thometz**, Maple Grove, MN (US); **Fertac Bilge**, South Lake, TX (US); **Paul J. Buscemi**, Long Lake, MN (US); **David H. Donabedian**, Somerset, NJ (US)

No. 09/566,335, filed on May 8, 2000, now Pat. No. 6,319,276, which is a division of application No. 09/111,264, filed on Jul. 6, 1998, now Pat. No. 6,059,823, which is a division of application No. 08/600,834, filed on Feb. 13, 1996, now Pat. No. 5,871,537.

Publication Classification

(51) **Int. Cl.⁷** **A61F 2/06**
(52) **U.S. Cl.** **623/1.11; 623/1.15**

Correspondence Address:
VIDAS, ARRETT & STEINKRAUS, P.A.
6109 BLUE CIRCLE DRIVE
SUITE 2000
MINNETONKA, MN 55343-9185 (US)

(57) **ABSTRACT**

(21) Appl. No.: **10/369,910**

(22) Filed: **Feb. 18, 2003**

Percutaneous treatment of aortic aneurysms and like vascular anomalies by an apparatus and method wherein the apparatus is delivered via catheter and comprises a sleeve with at least one peripheral conduit which is caused to assume an expanded, rigid configuration by the introduction of a chemical or mechanical hardening means, whereby the sleeve is caused to assume an open cylindrical configuration for fluid flow therethrough.

Related U.S. Application Data

(60) Continuation of application No. 10/003,218, filed on Oct. 30, 2001, which is a continuation of application

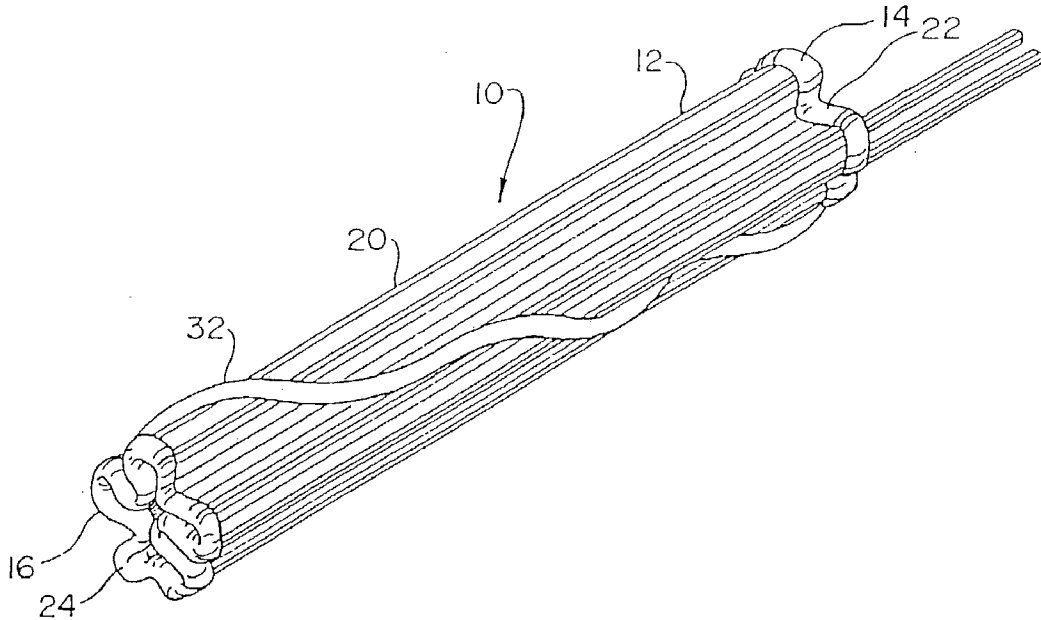

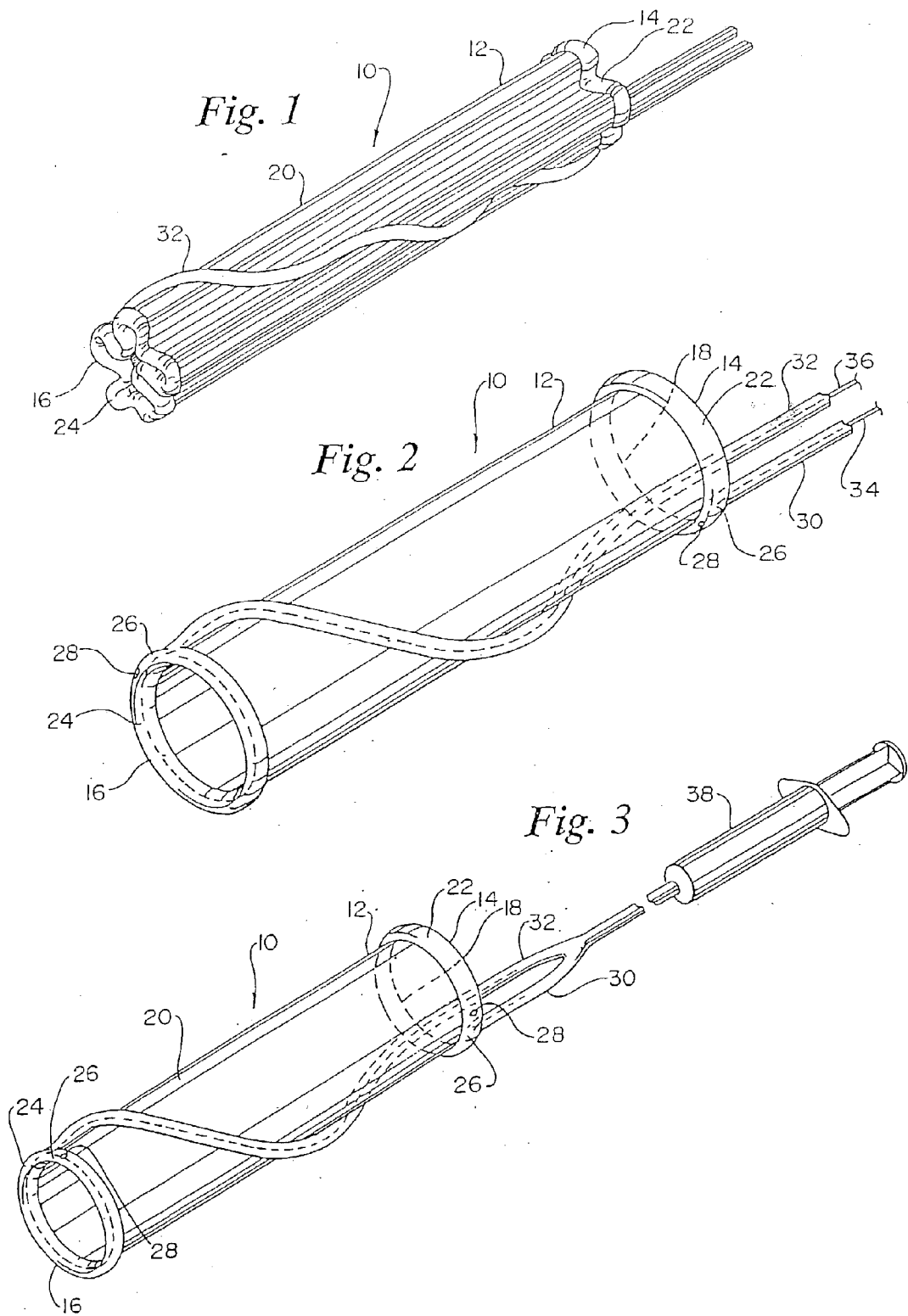

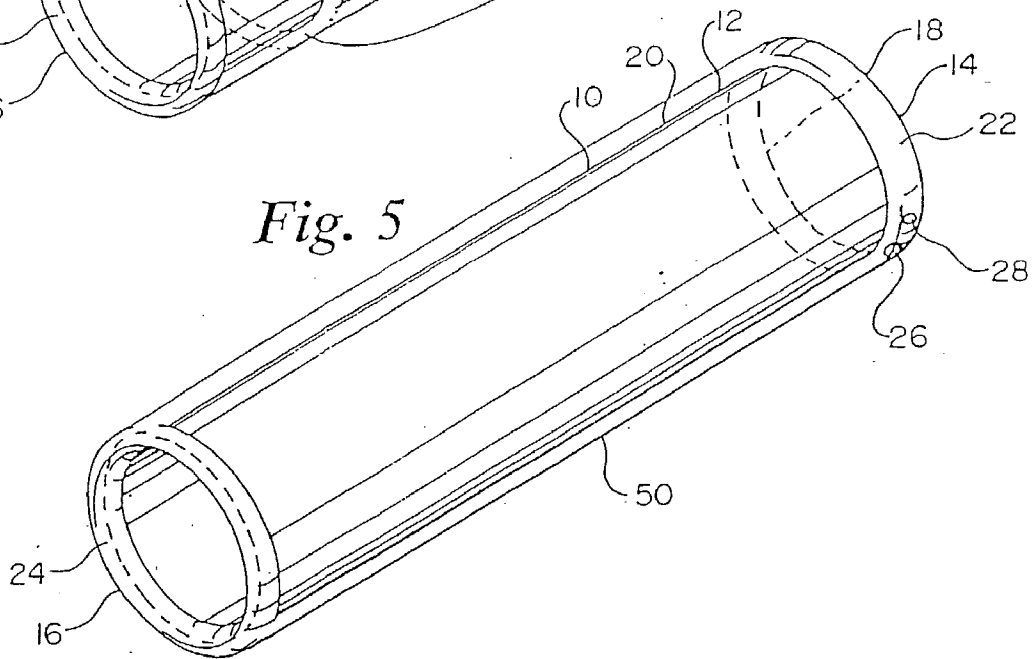
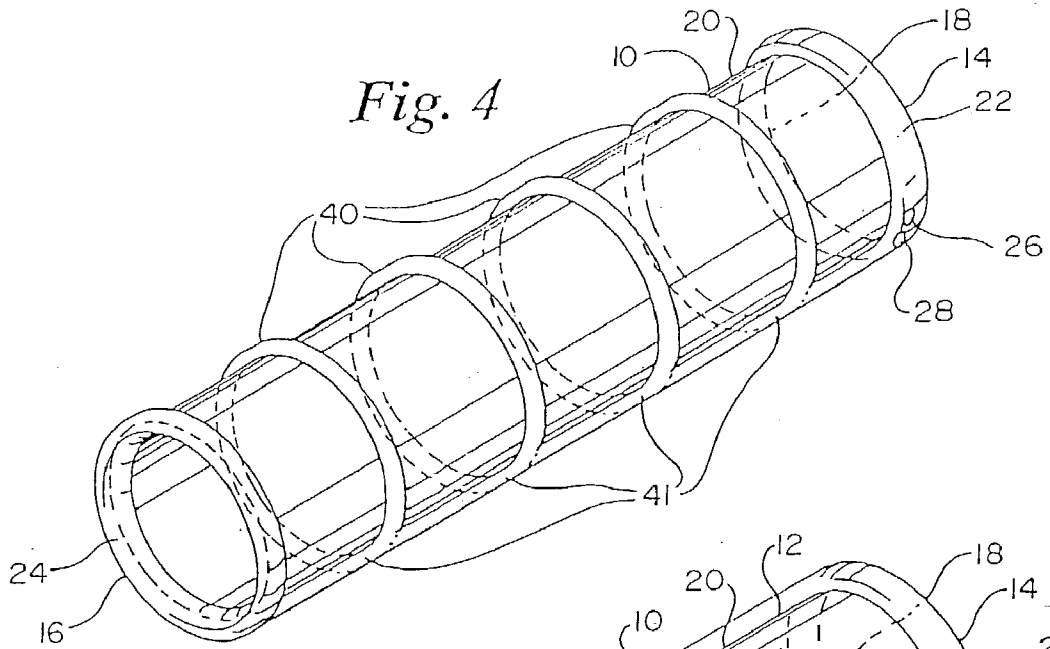

Fig. 6

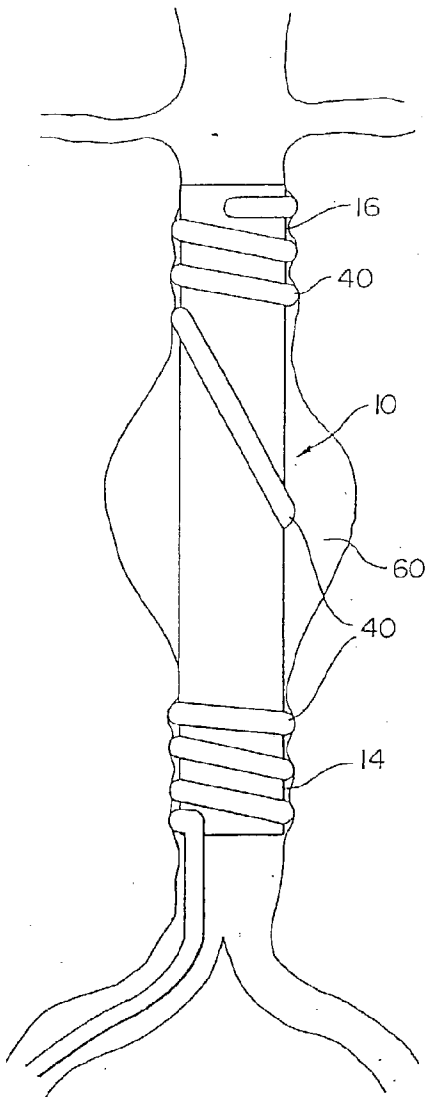

Fig. 7a

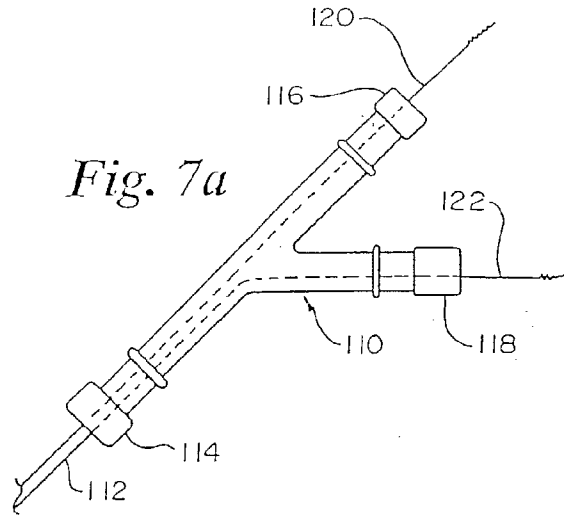

Fig. 7b

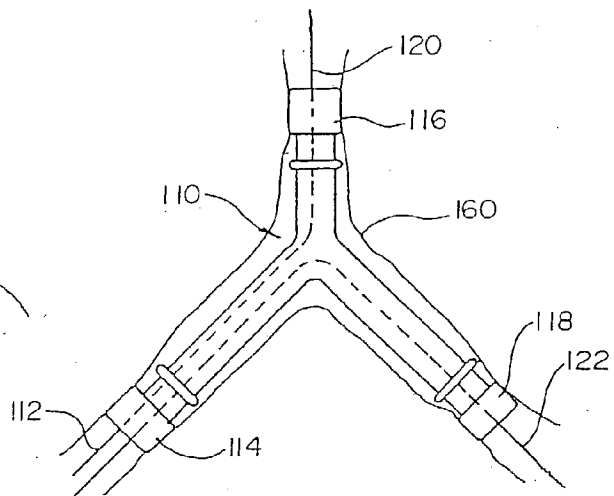

Fig. 8a

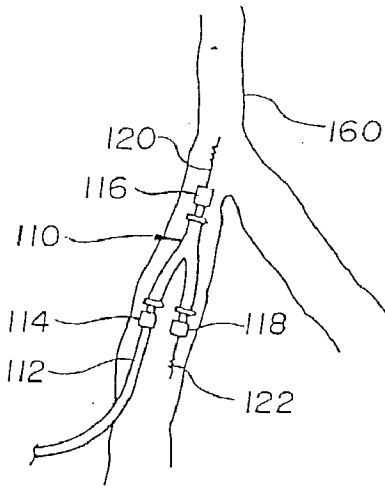

Fig. 8b

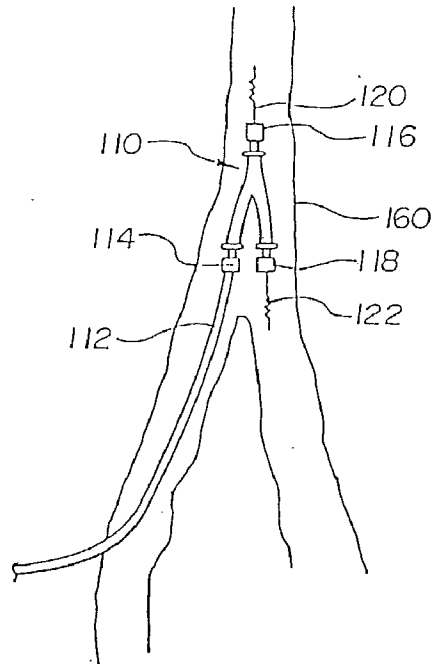

Fig. 8c

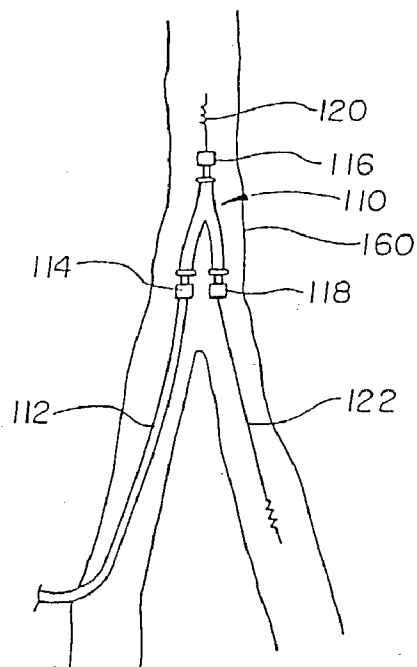

Fig. 8d

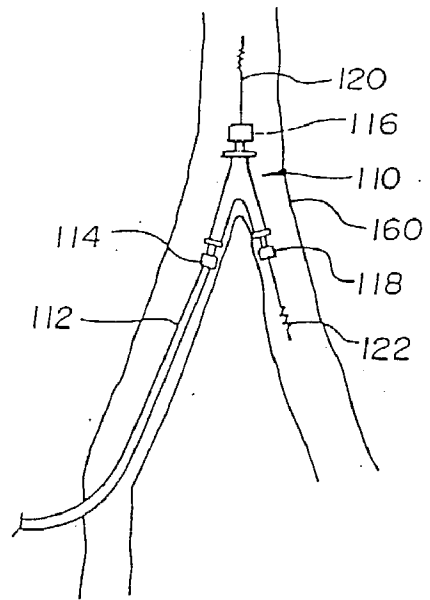

Fig. 9

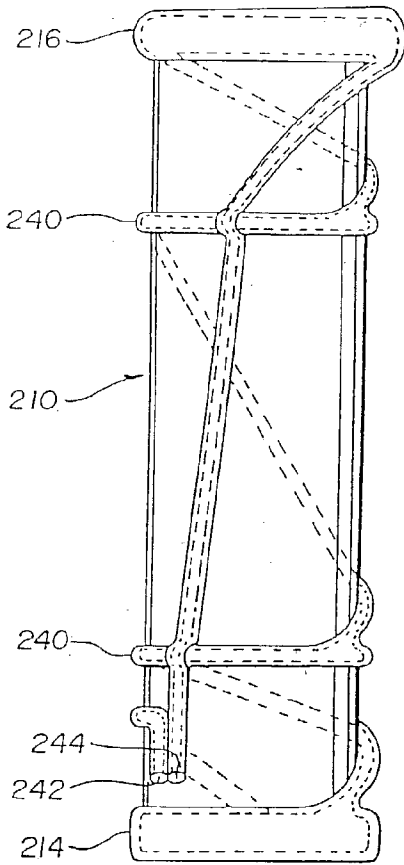

Fig. 10a

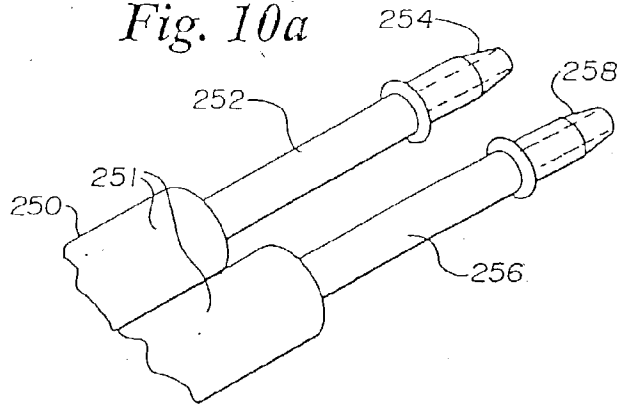

Fig. 10b

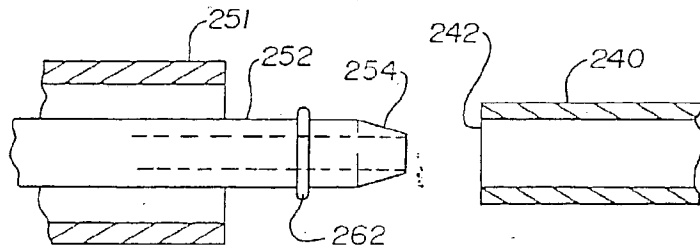

Fig. 10c

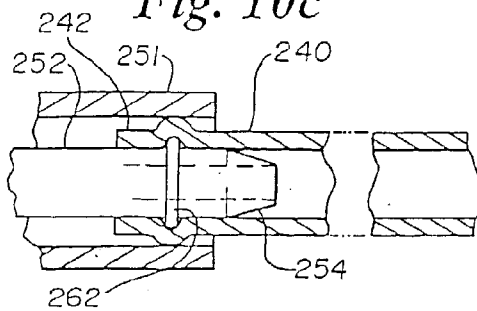

Fig. 11a

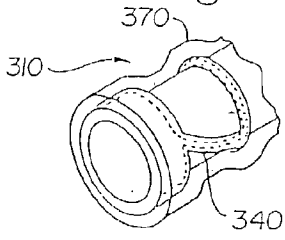

Fig. 11b

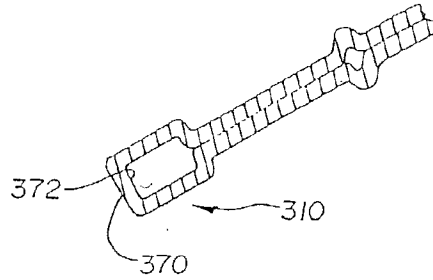

Fig. 11c

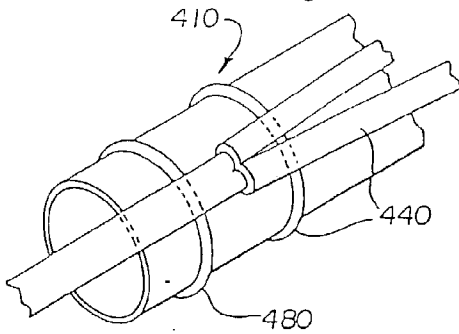

Fig. 11d

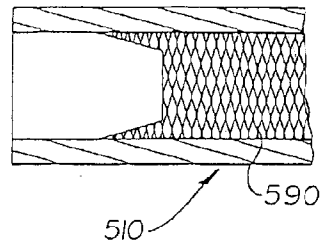

Fig. 12a

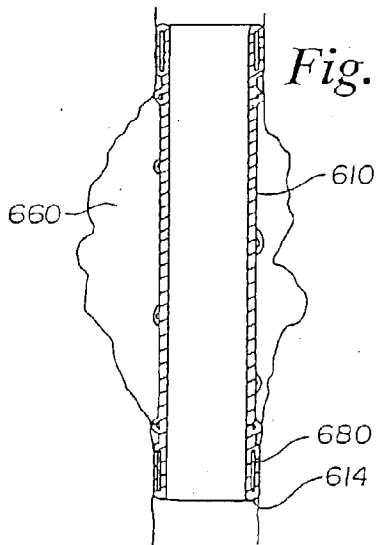
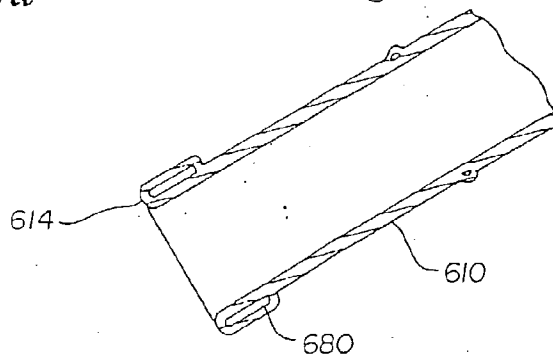

Fig. 12b



ENDOVASCULAR APPARATUS

BACKGROUND OF THE INVENTION

FIELD OF THE INVENTION

[0001] The present invention relates to the percutaneous treatment of vessels by an apparatus and method wherein the apparatus is delivered via catheter and comprises a surgical graft which is fixated in a vessel by means of a chemical or mechanical hardening-filler material system.

GENERAL BACKGROUND

[0002] Previous methods of treating aortic aneurysms include treatment via surgical procedure in which an incision is made in the abdomen or chest of the patient, the diseased area is cleaned by the surgeon and an artificial graft is sutured in place. This highly invasive procedure usually results in long hospital stays and lengthy recoveries. Further, mortality and morbidity complications often result as a consequence of this surgical procedure.

[0003] Other percutaneous methods have been attempted, such as are disclosed in U.S. Pat. No. 4,577,631 (utilizing occlusion catheters with pressure sensitive adhesives), U.S. Pat. No. 4,740,207 (self-expanding stent-type materials) and U.S. Pat. Nos. 4,271,839, 4,776,337 and 4,762,132 (other stent derived devices).

[0004] There still exists a need, however, for a simple method of repairing a vessel with an intravascular graft which allows normal tissue ingrowth to occur at the repair site. There exists a specific need for a percutaneous approach in which a catheter could be loaded with a surgical graft that can be fixated in a vessel such as the aorta.

SUMMARY OF THE INVENTION

[0005] The present invention provides devices for repairing aortic aneurysms and the like. The intraluminal graft of the present invention in one embodiment comprises a flexible linear or bifurcated tubular sleeve delivered to a repair site in a body by suitable means such as a catheter. The sleeve is suitably made of woven or cast material, and has peripheral conduits or tubes at each end. Each conduit has at least a single port that is connected to an elongated introduction means associated with the catheter delivery means. The introduction means may be attached to the outer surface of the sleeve. The collapsed sleeve may be made rigid and circular by the introduction through the introduction means of a chemical or mechanical hardening means.

[0006] The chemical hardening means may be a polymeric material introduced through the introduction means through an external source, such as a catheter or syringe. Alternatively, the mechanical hardening means may comprise a single wire or multiple wires inserted into the conduits to support the ends, or any portion of the sleeve. The wires are not attached to the sleeve but reside in the conduits to provide a constant spring tension. The wires may be of any suitable material which retains its tension, such as spring wire or memory wire.

[0007] The introduction means may be detached from the sleeve after introduction of the chemical or mechanical hardening means.

[0008] The sleeve may alternatively be associated with a fixation means comprising either a series of cylindrical tubules or an enclosure which fits over the sleeve, with a hardening-filler system enclosed therein. The hardening-filler system includes an activatable hardening material which may be provided in the form of microspheres that upon external agitation may be disrupted, allowing the contents to react together and form a hardened material that fills the tubules or enclosure, thereby expanding and rigidifying the fixation means, and fixing the sleeve in place in the site of repair. Polymeric materials which are activatable include thioisocyanates, aldehydes, isocyanates, divinyl compounds, epoxides or acrylates. In addition to the aforementioned, photoactivatable crosslinkable groups as succinimidyl azido salicylate, succinimidyl-azidobenzoate, succinimidyl dithio acetate, azidoiodobenzene, fluoro nitrophenylazide, salicylate azides, benzophenone-maleimide, and the like may be used as photoactivatable crosslinking reagents. The material may also consist of a thin coating which can be activated by external forces such as laser, radio frequency, ultrasound or the like, with the same hardening result taking place. These materials would allow for normal tissue ingrowth to take place.

BRIEF DESCRIPTION OF THE FIGURES

[0009] FIG. 1 shows a perspective view of a vascular graft according to the present invention in a folded state prior to placement and expansion thereof;

[0010] FIG. 2 shows a perspective view of the vascular graft in an expanded state by means of wires;

[0011] FIG. 3 is a perspective view of the device as in FIG. 2 showing the introduction of chemical hardening material via syringe;

[0012] FIG. 4 is a perspective view of an alternate embodiment comprising a series of cylindrical tubules;

[0013] FIG. 5 is a perspective view of an alternative embodiment of the device, where the vascular graft includes an enclosure which fits over the sleeve;

[0014] FIG. 6 is an alternative embodiment of the present invention having a fluid track comprising a continuous cylindrical tubule which is helically wound around the proximal and distal ends of the sleeve;

[0015] FIGS. 7a and 7b represent an alternative embodiment comprising a bifurcated vascular graft including a dual guide wire delivery system;

[0016] FIGS. 8a through 8d show placement of a bifurcated vascular graft according to the present invention;

[0017] FIG. 9 shows a further alternative embodiment of a vascular graft according to the present invention;

[0018] FIGS. 10a through 10c show filling of the cylindrical tubules after placement of the graft;

[0019] FIGS. 11a through 11d are fragmentary views of vascular grafts according to the present invention; and

[0020] FIGS. 12a and 12b are cross sectional views of a vascular graft according to the present invention.

DETAILED DESCRIPTION OF THE INVENTION

[0021] The present invention provides a device and method for repairing an aneurysm or the like in a vessel, such as the aorta.

[0022] Referring to FIGS. 1 and 2, a vascular graft comprising a sleeve is shown generally at 10. Sleeve 10 is shown in a folded conformation in FIG. 1 and in an expanded state in FIG. 2. Sleeve 10 is either a flexible linear or bifurcated (as shown in FIGS. 7-12) tubular sleeve made of woven or extruded cast material. Sleeve 10 is made of a biocompatible polymeric material. Fabrics from which sleeve 10 may be made are polyamides, such as nylon 6, nylon 6,6, and the like, Dacron®, polyesters, such as PET, polyethers, fluorinated polymers, such as polytetrafluoroethylene (PTFE), or biodegradable or nonbiodegradable fibers derived from natural sources such as carbohydrates, collagens, and proteins. The fabric may be of a woven knit, or solid structure. The most preferred materials are Dacron® and PTFE. Sleeve 10 is suitably delivered by a catheter. Catheters of polyurethane, PTFE, PVC silicone or the like with internal diameters of 1 to about 3 mm are suitable for polymer injection.

[0023] Sleeve 10 has a proximal end 14, a distal end 16, an interior portion 18, an exterior portion 20 and peripheral circular conduits or tubes 22,24 located one at each end 14,16, respectively. Each conduit 22,24 has at least one inlet port 26 and at least one outlet or exhaust port 28, inlet(s) 26 being connected to elongated introduction means 30,32 respectively. Introduction means 30,32 may be attached to exterior portion 18 of sleeve 10. Referring to FIG. 2, collapsed sleeve 10 is expanded and made rigid by the insertion of a spring wire or wires 34,36 inserted through introduction means 30,32. A single wire or multiple wires may be inserted to support ends 14,16, the center body or any portion of sleeve 10. Wires 34,36 are not attached to sleeve 10 but reside in introduction means 30,32 or conduits 22,24, providing a constant spring tension. The entrance tubing may be detached from the sleeve after placement of supporting wires 34,36 in end tubes 22,24.

[0024] The supporting wire may be made of stainless steel, spring steel, memory shape metals (such as nitinol, for example), titanium, or metal alloys of any kind, not limited to the aforementioned. Furthermore, the configuration of the supporting wire may be solid, braided or woven.

[0025] As shown in FIG. 3, the graft may be expanded and made rigid and circular by a chemical hardening means introduced into a single spiral tube, or alternatively, as shown in FIG. 4, a series of interconnected concentric cylindrical tubules 40 attached to and encasing the sleeve 10. Tubules 40 are interconnected by means of connecting tubes 41 extending between the tubules. The chemical hardening means may be introduced in the form of an injectable polymeric material comprised of a one part system, a two part system, self expanding systems, thermosets, thermoplastics and the like. These polymers or polymeric systems would fill tubes 32 or tubules 40, causing them to expand and rigidify, thereby fixing the sleeve at the site of repair. This embodiment is of particular use for fusing such grafts in large vessels such as the aorta or pulmonary arteries.

[0026] Two part activatable hardening material may be supplied in the form of microspheres (not shown) that upon agitation by an external force may be disrupted. The external energy could originate from any suitable source including IR, visible or UV light through optic fiber or mechanical vibrational means from about 1 to 100,000 hertz supplied by mechanical or electrical transducers or by heat upon disruption

of the microspheres, the activatable hardening material is liberated and allowed to harden. Disruption of the microspheres releases the separated components, allowing the components to react together and form a hardened material that fills series of tubules 40 thereby fixing sleeve 10 in place at the site of repair. Polymeric systems may be comprised of vinyl or divinyl compounds in which an initiator is contained in the microspheres, epoxies containing microencapsulated amine component, or diisocyanates with encapsulated amine or hydroxyl terminated prepolymers. Amino groups can be so isolated from methylacetimidate, ethyl acetimidate, dimethylglutarimidate, dimethyl adipidate, dimethyl sebaimidate, dithionyl propioimidate, dimethyl oxydipropionimidatesuccinate bis-esters, disuccinimidyl tartarate, dicyanotobenzene, dichlorodinitrobenzene, adipaldehyde, glutaraldehyde and the like.

[0027] These hardening-filler systems would allow for normal tissue ingrowth in series of tubules 40 to take place. Because the tubules comprise only a small fraction of the total surface area of the sleeve, these hardening filling systems would allow for tissue ingrowth to take place into the sleeve material not impeded by the tubules, providing further reinforcement of the placement of the sleeve 10.

[0028] In a further embodiment shown in FIG. 5, the material may be introduced by means of a hardening-filler system comprising an enclosure 50 attached to sleeve 10. Enclosure 50, like tubules 40, is filled with an activatable hardening material consisting of either a one-part polymer system, a two-part polymer system or a self-expanding monomer, which upon polymerization would fill enclosure 50, causing it to expand and rigidify, thereby fixing sleeve 10 at the site of repair. The activatable hardening material is described above with reference to FIG. 4.

[0029] Referring now to FIG. 6, an alternative embodiment of sleeve 10 is shown in place at a repair site 60. Sleeve 10 has a fluid track comprising a continuous cylindrical tubule 40 which is helically wound around proximal end 14 and distal end 16 of sleeve 10. Tubule 40 can be filled with a curing polymer selected from thermoset polymers or two part polymers, as described hereinabove. Sleeve 10 may optionally include supplemental physical attachment means (not shown) such as spikes, barbs or the like at proximal and distal ends 14,16.

[0030] FIGS. 7-9 represent an alternative embodiment comprising a bifurcated vascular graft 110 including a dual guide wire delivery system 112. Graft 110 has a proximal end 114 and at least two distal ends 116,118. FIGS. 8a through 8d show placement of bifurcated vascular graft 110 at a repair site 160 where the vessel bifurcates. Graft 110 and delivery system 112 are advanced through a vessel to repair site 160. Delivery system 112 includes guide wires 120,122 whereby ends 114,116,118 are placed at different branches of the vessel bifurcation. FIG. 7b shows graft 110 in place at site 160.

[0031] FIGS. 9-12 show an alternative embodiment of a vascular graft according to the present invention, indicated generally at 210. Graft 210 has proximal and distal ends 214,216 and cylindrical tubule 240. Tubule 240 has a first end 242 and a second end 244, located near proximal end 214. After placement of graft 210, tubule 240 is filled.

[0032] Referring to FIGS. 10a, 10b and 10c, filling means 250 is shown. Although filling means 250 is shown in

conjunction with a tubular vascular graft, such a filling means may be used with any vascular graft according to the present invention. Filling means 250 comprises casing 251, filling tube 252 with distal infusion inlet 254 and exhaust tube 256 with distal exhaust vent 258. Filling means 250 may be incorporated into the vascular graft delivery means or may alternatively be separate from but associated with the delivery means. FIG. 10b is an enlarged fragmentary view of filling tube 252 which shows the manner in which infusion inlet 254 connects to first end 242 of tubule 240, via pinch ring 262 located near the distal end of infusion inlet 254. Distal end of infusion inlet 254 is advanced into end 242 of tubule 240 until pinch ring 262 is inserted in tubule 240. As shown in FIG. 10c, casing 251 of filling means 250 is advanced over end 242 of tubule 240 whereby pinch ring 262 creates an interference fit between filling tube 252 and end 242 of tubule 240. Exhaust vent 258 connects to end 244 of tubule 240 in the same manner.

[0033] FIGS. 11-12 show alternative embodiments of the inventive vascular graft. FIG. 11a shows a graft 310 having an outer layer 370 surrounding tubules 340. FIG. 11b shows graft 310 having two outer layers 370, 372 surrounding tubules 340. FIG. 11c shows graft 410 having no outer layer over tubules 440, and lacking connection between tubule 440 and proximal coil 480. FIG. 11d shows a cross section of graft 510, having an inner core 590. FIGS. 12a and 12b show a longitudinal cross section of graft 610 in place in repair site 660, wherein graft 610 has an enlarged proximal coil 680 located directly at proximal end 614 of graft 610, i.e. not more than about 5 mm from proximal end 614.

[0034] The unique features of the device are the manner of its delivery and fixation at the site of repair, its low profile which may prevent interference with normal heart functions, and the non-invasive nature of the delivery which would reduce costs normally associated with closure of such a defect. The device and method of fixation provides a non-invasive treatment of aortic aneurysms and the like. The device is made of polymeric material and is delivered via catheter in a non-invasive procedure. In one embodiment, the device operates through chemical means to repair an aneurysm.

[0035] Advantages of the apparatus and method of the present invention are many. No preformed stent is required and the apparatus has a smaller insertion diameter than previous vascular grafts. Further, the vascular graft has a lower cost of production than previous graft materials and procedures.

[0036] The practice of the present invention achieves several objectives and advantages. Currently, there are no percutaneous devices available to cure a septal defect or the like. The device and method of the present invention provides an advantage over surgery in that the cost of the procedure is substantially less, the risk of infection is less, the hospital residency time is less and there is no physically deforming scar.

[0037] Further advantages include applicability to procedures such as repair of PDA, patent ductus anomaly. The non-invasive mode of delivery would reduce costs associated with this type of procedure. In addition, the low profile of the apparatus may minimize or prevent interference with normal heart functions.

[0038] While this invention may be embodied in many different forms, there are described in detail herein specific

preferred embodiments of the invention. This description is an exemplification of the principles of the invention and is not intended to limit the invention to the particular embodiments illustrated.

[0039] The above Examples and disclosure are intended to be illustrative and not exhaustive. These examples and description will suggest many variations and alternatives to one of ordinary skill in this art. All these alternatives and variations are intended to be included within the scope of the attached claims. Those familiar with the art may recognize other equivalents to the specific embodiments described herein which equivalents are also intended to be encompassed by the claims attached hereto.

What is claimed is:

1. A vascular graft device comprising:

- a) a flexible, tubular sleeve configuration having at least one axis therethrough and further comprising a first end, at least one opposite end and an exterior portion;
- b) at least one peripheral conduit surrounding said sleeve, each said at least one peripheral conduit having an inlet port;
- c) delivery means connected to at least one conduit at its inlet port, said delivery means being in association with a hardening means;

whereby when the device is delivered to an area of a vessel having an aneurysm such that the device is positioned at the aneurysm and the hardening means is delivered, the hardening means causes the at least one peripheral conduit to assume an expanded, rigid configuration which fits securely into the vessel and is anchored thereto by pressure, causing the sleeve to be supported in an open condition for fluid flow there-through.

2. The device of claim 1 further comprising at least one additional conduit surrounding the sleeve, said additional conduit being located at the first end of the sleeve.

3. The device of claim 1 further comprising a plurality of conduits surrounding the sleeve, said conduits being located between the first end and an opposite end of the sleeve.

4. The device of claim 1 further comprising an enclosure over the exterior portion of the sleeve between the first end and an opposite end thereof.

5. The apparatus of claim 1 wherein the hardening means comprises an activatable hardening material selected from the group consisting of one-part polymer systems, two-part polymer systems and self-expanding monomers, the apparatus further comprising a source of hardening material in association with the delivery means.

6. The apparatus of claim 5 wherein the hardening means further comprises at least one receptacle containing the activatable hardening material.

7. The apparatus of claim 6 further comprising a plurality of microspheres wherein the activatable hardening material is carried, said microspheres being located within the receptacle and further being constructed and arranged to release the activatable hardening material upon disruption, thereby allowing the activatable hardening material to harden.

8. The apparatus of claim 6 wherein the activatable hardening material comprises a first component and a second component isolated from each other by and carried in said microspheres, said microspheres being constructed and

arranged to release said first and second components upon disruption, thereby allowing the components to react and harden.

9. The device of claim 1 wherein each said at least one peripheral conduit has an outlet port, whereby when the device is delivered to an area of an artery having an aneurysm such that the device is positioned at the aneurysm and hardening means is introduced, the peripheral conduits are substantially filled with hardening means and are thereby caused to assume an expanded, rigid configuration which fits securely into the vessel and is anchored thereto by pressure, causing the sleeve to be supported in an open condition for fluid flow therethrough.

10. The device of claim 9 further comprising at least one additional conduit surrounding the sleeve, said additional conduit being located between the first end and an opposite end of the sleeve.

11. A vascular graft device comprising:

- a) a flexible tubular sleeve configuration having at least one axis therethrough and further comprising a first end, at least one second end, an interior portion and an exterior portion;
- b) a peripheral conduit surrounding each of said ends, each peripheral conduit having at least one entrance port; and
- c) introduction means in communication with the port of each end tube for introduction of a hardening means;

whereby when the device is delivered to an area of an artery having an aneurysm such that the sleeve is positioned at the aneurysm, and hardening means is introduced, the peripheral conduits are caused to assume an expanded, rigid configuration which fits securely into the artery and is anchored thereto by pressure, causing the sleeve to be supported in an open condition for fluid flow therethrough.

12. An apparatus for repairing an arterial aneurysm, the apparatus comprising:

- a) a catheter delivery means; and
- b) an arterial graft device comprising:
 - i) a flexible, tubular sleeve configuration having at least one axis therethrough and further comprising a first end, at least one opposite end, and exterior and interior portions;
 - ii) a peripheral conduit surrounding the sleeve and having at least one port;
 - iii) introduction means associated with the catheter delivery means and being in communication with each at least one port; and
 - iv) hardening means delivered through said introduction means for causing the arterial graft device to assume a rigid cylindrical configuration;

whereby when the apparatus is delivered to an area of an artery having an aneurysm such that the sleeve is positioned at the aneurysm and hardening means is introduced, the conduits are caused to assume a rigid, expanded configuration which fits securely into the artery and is anchored thereto by pressure, causing

the sleeve to be supported in an open condition for fluid flow therethrough, and causing the aneurysm to be repaired.

13. The apparatus of claim 12 wherein the sleeve is made of a nonbiodegradable, biocompatible polymeric material.

14. The apparatus of claim 13 wherein the polymeric material is selected from the group consisting of thermosetting polymers, thermoplastic polymers, thermoplastic elastomers, elastomers, composites, pseudo-thermoplastics, carbohydrates, proteins, and mixtures thereof.

15. The apparatus of claim 12 wherein the sleeve is made of a material selected from the group consisting of Dacron® or PTFE.

16. The apparatus of claim 12 wherein the sleeve is made of a woven or braided material.

17. The apparatus of claim 12 wherein the sleeve is made of a material selected from the group consisting of polyamides, nylon 6, nylon 6,6, polyesters, PET, polyethers, fluorinated polymers, polytetrafluoroethylene, biodegradable or nonbiodegradable fibers derived from natural sources such as carbohydrates, collagens, and proteins, and mixtures thereof.

18. The apparatus of claim 17 wherein the sleeve is biodegradable.

19. The apparatus of claim 12 wherein:

- a) the hardening means comprises at least one wire for insertion into and extension through the introduction means into a peripheral conduit.

20. The apparatus of claim 19 wherein the wire is made of a material selected from the group consisting of stainless steel, spring steel, memory shape metals, and metal alloys.

21. The apparatus of claim 20 wherein the wire is made of nitinol.

22. The apparatus of claim 20 wherein the wire is made of titanium.

23. The apparatus of claim 12 wherein the peripheral conduit has an inlet port and an exhaust port and wherein the hardening means is a polymeric material.

24. The apparatus of claim 23 wherein the polymeric material is introduced through the introduction means via an external source.

25. The apparatus of claim 23 wherein the external source is a syringe.

26. The apparatus of claim 23 wherein the external source is a catheter.

27. The apparatus of claim 13 wherein the hardening means comprises an activatable hardening material selected from the group consisting of one-part polymer systems, two-part polymer systems and self-expanding monomers.

28. The apparatus of claim 27 wherein the hardening means further comprises a plurality of microspheres wherein the activatable hardening material is carried, said microspheres being constructed and arranged to release the activatable hardening material upon disruption, thereby allowing the activatable hardening material to harden.

29. The apparatus of claim 28 wherein the activatable hardening material comprises a first component and a second component isolated from each other by and carried in said microspheres, said microspheres being constructed and arranged to release said first and second components upon disruption, thereby allowing the components to react and harden.