

A. HYDE & G. BUCHANAN.

SELF WAITING STAND.

APPLICATION FILED MAY 8, 1904.

2 SHEETS—SHEET 1.

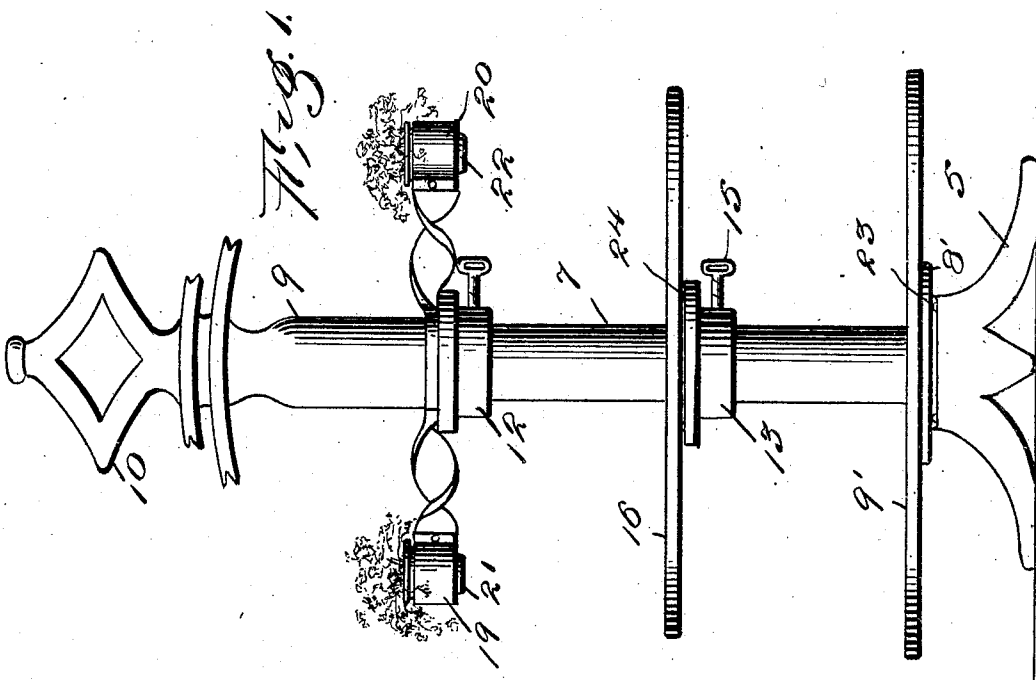
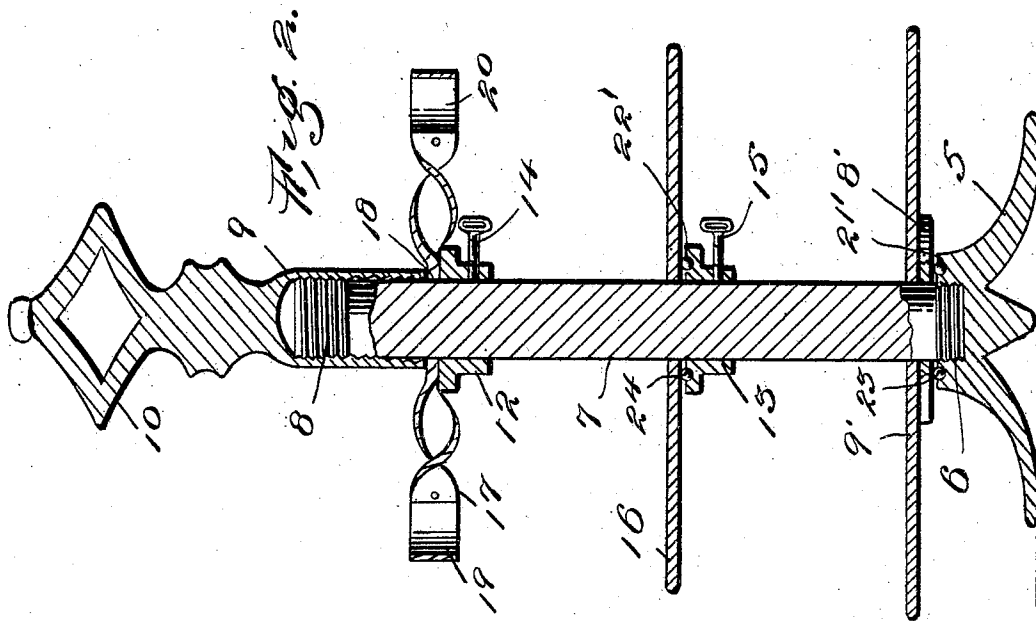

Witnesses  
*Amberman*  
*W. C. Key*

*A. Hyde* Inventors  
*G. Buchanan*

*Charles Chandler* By  
 Attorneys

A. HYDE & G. BUCHANAN.  
SELF WAITING STAND.  
APPLICATION FILED MAY 6, 1904.

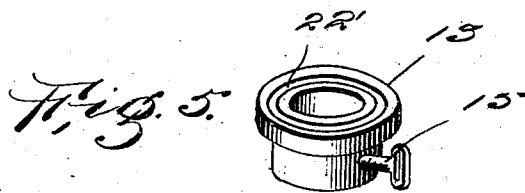
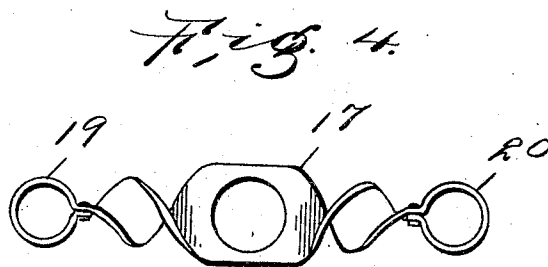
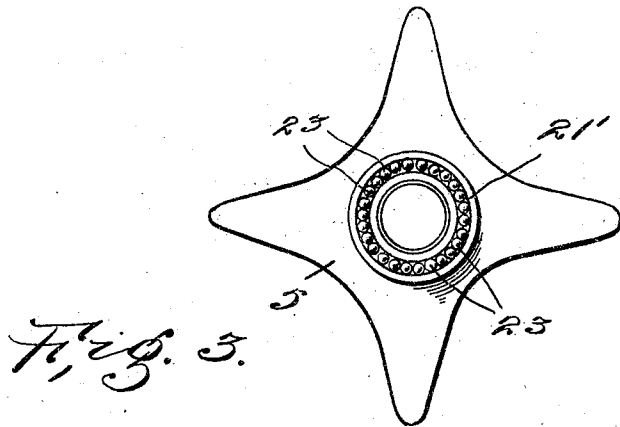

Witnesses  
*Amos*  
*W. C. Hayes*

Inventors  
*A. Hyde*  
*G. Buchanan*  
 BY  
*Charles* *Charles*  
 Attorneys

# UNITED STATES PATENT OFFICE.

ARTHUR HYDE AND GEORGE BUCHANAN, OF WADSWORTH, NEVADA.

## SELF-WAITING STAND.

No. 795,837.

Specification of Letters Patent.

Patented Aug. 1, 1905.

Application filed May 6, 1904. Serial No. 206,744.

*To all whom it may concern:*

Be it known that we, ARTHUR HYDE and GEORGE BUCHANAN, citizens of the United States, residing at Wadsworth, in the county of Washoe, State of Nevada, have invented certain new and useful Improvements in Self-Waiting Stands; and we do hereby declare the following to be a full, clear, and exact description of the invention, such as will enable others skilled in the art to which it appertains to make and use the same.

This invention relates to stands for holding food of that general class known as "self-waiting stands," the object of the invention being to provide a cheap and simple construction which may be placed upon the table and which comprises a plurality of rotatable platforms which may be adjusted on their common support, other objects and advantages of the invention being understood from the following description.

In the drawings forming a portion of this specification, and in which like numerals of reference indicate similar parts in the several views, Figure 1 is an elevation of a construction embodying the present invention. Fig. 2 is a section taken vertically through the construction shown in Fig. 1. Fig. 3 is a top plan view of the base. Fig. 4 is a top plan view of the plant-support. Fig. 5 is a detail view of one of the collars for adjustably supporting the plant-supporting means.

Referring now to the drawings, there is shown a stand comprising a base 5 of suitable size, in the upper end of which is formed a threaded socket 6, in which is engaged an upright or post 7, the upper end of which is threaded, as shown at 8, to receive a cap 9, the upper portion of which is of skeleton formation, as shown at 10, and may be used as a handle by which the stand may be carried.

Upon the upright 7 and resting upon the upper end of the base 5 is rotatably mounted a plate 8', upon which is received a disk-shaped platform 9', which is adapted to rotate with the plate, the platform 9' being designed to support dishes or vessels containing food.

Upon the upright 7 above the platform 9' and spaced vertically are disposed collars 12 and 13, which may be slid vertically upon the upright and may be held at different points of their adjustment by the set-screws 14 and 15, respectively.

Disposed upon the upright 7 and resting upon the upper end of the collar 13 is a second disk-shaped platform 16, which is rotata-

ble and is designed also to receive and support dishes or vessels containing food.

Above the collar 12 and resting thereon is a plant-support consisting of a metal bar 17, having a central opening 18, in which the upright 7 is received, the bar being twisted at both sides of the upright and having its ends bent to form loops 19 and 20 to receive flower-pots, as shown at 21 and 22.

To facilitate rotation of the platforms 9' and 16, the base and the collar 13 may have grooves 21' and 22' respectively formed therein, and bearing-balls 23 and 24, respectively disposed in the grooves to support a platform.

With the construction above described the platforms may be readily rotated to bring before the operator any part thereof, and they may be adjusted to different heights to suit various working conditions.

What is claimed is—

1. A self-waiting stand comprising a base having a screw-threaded opening in its upper end, an upright having its lower end engaged within the said opening, a plate rotatably engaged with the upright and supported from the base, a platform rotatably engaged with the upright and resting upon the plate, collars adjustably engaged with the upright, a platform rotatably engaged with the upright and supported from the lowermost collar, a plant-support engaged with the upright and resting upon the uppermost collar, the plant-support having sockets to receive flower-pots.

2. A self-waiting stand comprising a base having an opening in its upper end, an upright engaged with the opening in said base, a plate rotatably engaged with the upright and supported from the base, a platform rotatably engaged with the upright, and resting upon the plate, collars adjustably engaged with the upright, a platform rotatably engaged with the upright and supported from the lowermost collar, a plant-support engaged with the upright and resting upon the uppermost collar, the plant-support having sockets to receive flower-pots, the portions of the said supports between the upright and sockets being twisted, and a handle disposed upon the upper end of the upright.

In testimony whereof we affix our signatures in presence of two witnesses

ARTHUR HYDE.  
GEORGE BUCHANAN.

Witnesses:

GEO. A. ABBEY, Jr.,  
VICTOR G. HINDMARSH.