

Nov. 5, 1957

J. M. HOFFMAN

2,812,516

GARMENT WITH ELASTICIZED OPEN CROTCH

Filed April 1, 1955

2 Sheets-Sheet 1

Fig. 1

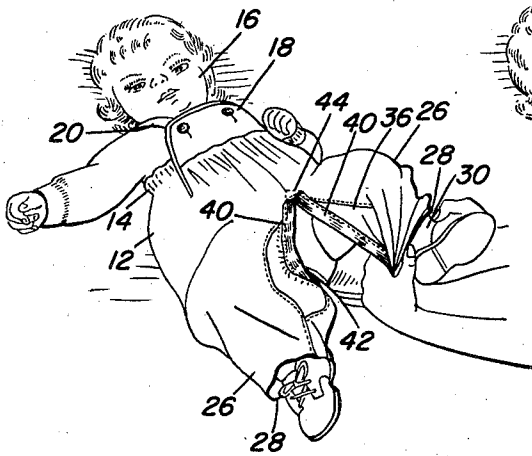

Fig. 2

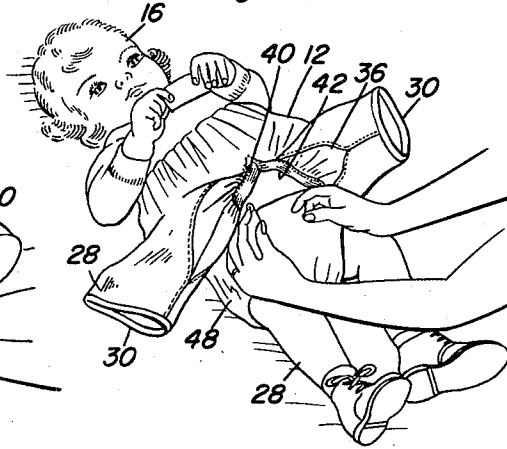
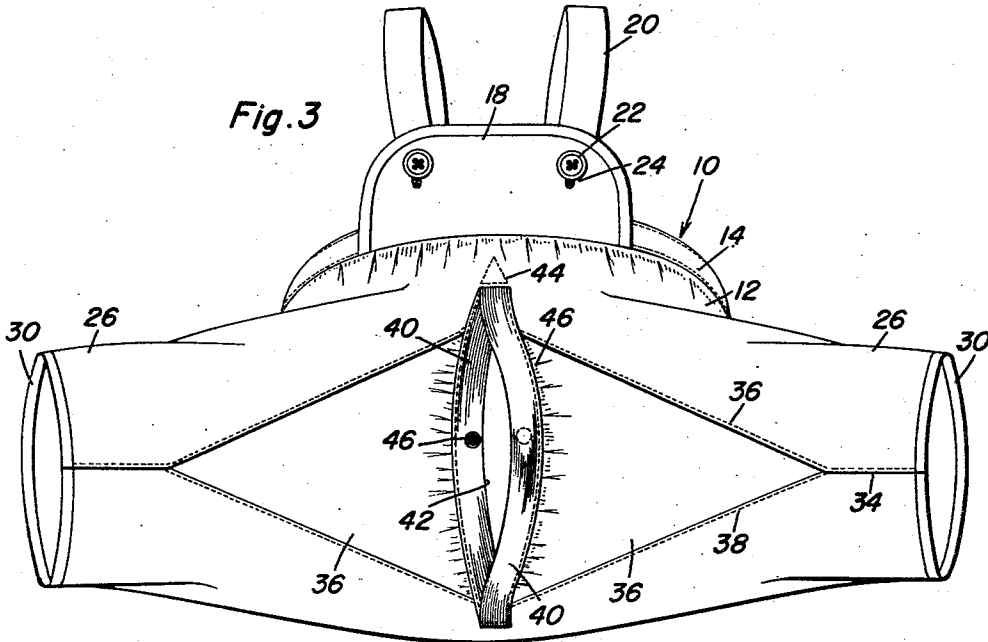

Fig. 3



Joan M. Hoffman  
INVENTOR.

BY *Olance A. Dion*  
and *Harvey R. Jacobson*  
Attorneys

Nov. 5, 1957

J. M. HOFFMAN

2,812,516

GARMENT WITH ELASTICIZED OPEN CROTCH

Filed April 1, 1955

2 Sheets-Sheet 2

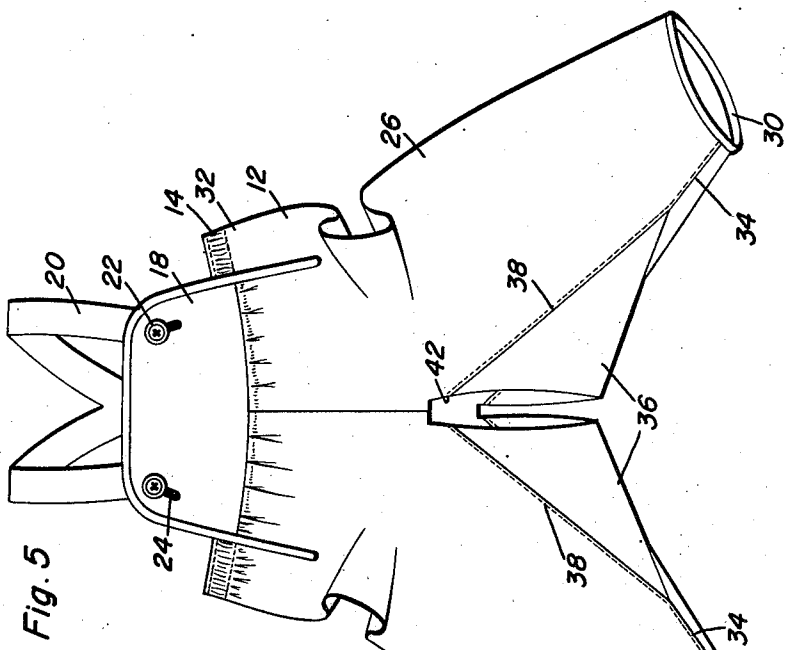

Fig. 5

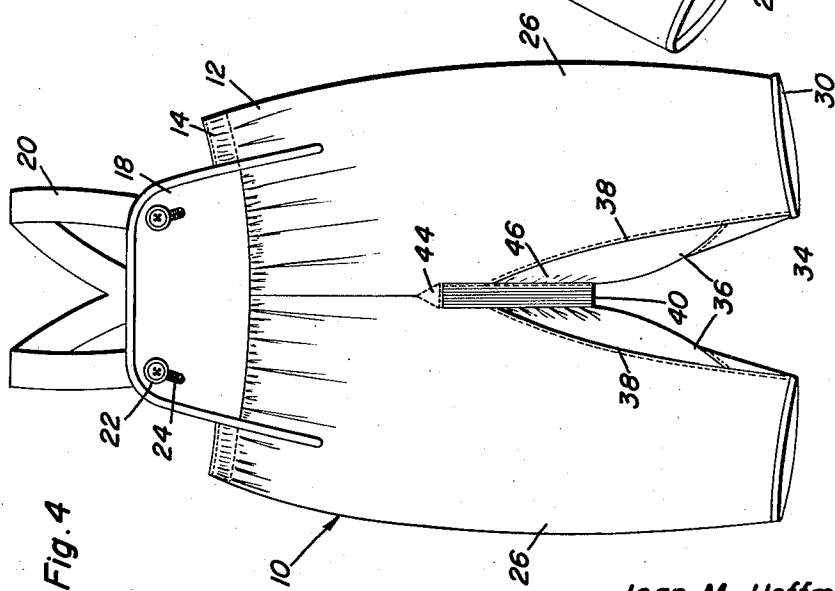

Fig. 4

Joan M. Hoffman  
INVENTOR.

BY *Chance A. Dixon*  
*and Harvey B. Jackson*  
Attorneys

1

2,812,516

## GARMENT WITH ELASTICIZED OPEN CROTCH

Joan M. Hoffman, St. Paul, Minn.

Application April 1, 1955, Serial No. 498,659

1 Claim. (Cl. 2--80)

This invention generally relates to garments, and more specifically provides improved and novel construction in an infant's garment having an elasticized open crotch to facilitate the changing of the infant's diapers.

An object of the present invention is to provide a garment with an elasticized open crotch so constructed that the legs of the infant wearing the garment may be projected through the open crotch with the crotch portion disposed around the waist of the infant thereby facilitating the removal and replacement of a diaper normally worn by the infant.

Another object of the present invention is to provide a garment having an elasticized open crotch including a body enclosing portion and leg portions having slack constructed therein together with an open crotch portion having elastic edges wherein the elastic normally retains the open crotch in closed position but permits removal of the infant's legs from the leg portions of the garment so that the infant's diaper may be exposed to facilitate the replacement thereof.

Still another important object of the present invention is to provide a garment in accordance with the preceding objects which is simple in construction, easy to place on an infant and remove therefrom, well adapted for its intended purpose and relatively inexpensive to manufacture.

These together with other objects and advantages which will become subsequently apparent reside in the details of construction and operation as more fully hereinafter described and claimed, reference being had to the accompanying drawings forming a part hereof, wherein like numerals refer to like parts throughout, and in which:

Figure 1 is a perspective view showing the garment having an elasticized open crotch positioned on an infant with the leg being removed from the leg portion of the garment for insertion through the open crotch;

Figure 2 is a perspective view similar to Figure 1, showing both leg portions of the garment removed from the infant's legs and the open crotch positioned around the waist portion of the infant for permitting access to the diaper for replacement thereof;

Figure 3 is a bottom view showing the open crotch construction of the garment of the present invention;

Figure 4 is a front elevational view of the garment of the present invention; and

Figure 5 is a front elevational view similar to Figure 4 showing the construction of the garment of the present invention prior to the installation of the elasticized edges of the open crotch for urging the open crotch to a closed position.

Referring now specifically to the drawings, it will be seen that the numeral 10 generally designates the garment of the present invention which is illustrated in the form of a pair of overalls, although it will be understood that the principles of the present invention may be utilized in any type of garment normally employed for relatively small infants which includes leg covering portions.

The garment 10 generally includes a body enclosing or encircling portion 12 having a waist band 14 at the open

2

upper end thereof for positioning around the waist of an infant 16. An upstanding bib 18 is provided at the upper end of the body enclosing portion 12, and a pair of shoulder straps 20 are secured to the rear edge of the body enclosing portion 12 for extending over the shoulders of the infant 16, and each of the straps 20 is provided with a fastening button 22 adapted to be inserted through buttonholes 24 in the upper corners of the bib 18. Integrally formed with and extending downwardly from the body enclosing portion 12 of the garment 10 is a pair of tubular leg portions 26 for enclosing the legs 28 of the infant 16. The tubular leg portions 26 are provided with open lower ends 30 and the waist band 14 may be provided with elastic for forming gathers 32 adjacent the waist band 14 for assuring a snug fit of the garment 10 around the waist portion of the infant 16.

Each of the tubular leg receiving portions 26 is formed with an inner seam 34 which extends upwardly from the open end 28 of the leg portion 26 and a generally triangular gusset 36 is inserted into the tubular leg portion 26 and secured thereto by diverging seams 38. The base portion of the triangular gusset 36 has an elongated elastic strap or band 40 secured thereto which forms an edge of an open crotch 42. The terminal ends of the elastic strap members 40 are secured to the body portion 12, as indicated by the numeral 44, and the terminal ends of the elastic straps 40 are attached in overlying relation so that the natural tendency of the straps 40 on the base edges of the gussets 36 will be to overlap each other. Where the bases of the gussets 36 are attached to the straps 40, gathers 46 are provided and the gussets 36 are normally slack and sag below the normal outline of the tubular leg receiving portions 26, substantially as illustrated in Figure 5. If desired, mating snap fastener elements 46 may be provided on the elasticized straps 40 for detachable engagement, thereby assuring that the straps 40 will be retained in overlapping relation, thereby assuring that the open crotch 42 will be retained in a neat appearing and closed position.

In practical use of the invention, the garment 10 is placed on the infant in the usual manner with the legs 28 of the infant 16 positioned in the tubular leg portions 26 and projecting outwardly from the open ends 30 thereof. When it is desired or necessary to remove and replace the diaper 48 positioned on the infant 16, it is not necessary to remove the straps 20 and completely remove the entire garment 10, but it is only necessary to grasp one edge of the open crotch 42 which is constituted by one of the elasticized straps 40 and stretch the same downwardly, thereby stretching the gusseted area 36 downwardly, and at the same time, move the leg 28 and foot of the infant 16 inwardly through the open end 30 of the tubular leg portion 26 and then extend the leg of the infant 16 outwardly through the open crotch 42. This procedure is repeated with both legs 28 of the infant 16, wherein the open crotch 42 is sufficiently large to be positioned around the waist portion of the infant 16, thereby permitting ready access to the diaper 48 for removal and replacement thereof. After the diaper 48 has been replaced, it is only necessary to reverse the procedure and insert the legs 28 of the infant 16 back through the open crotch 42 and then extend the legs 28 through the leg portions 26 of the garment 10.

The garment illustrated is that type known as an overall, and is constructed of knit fabric which is inherently stretchable, and the gusset portion 36 is so cut and arranged that it is highly stretchable and is also larger than would normally be employed in constructing the tubular leg portions 26, thereby providing a depending slack which is taken up by the gathers 46 that are formed by the elasticized straps 40 urging the base edges of the triangular gussets 36 upwardly towards the main body por-

3

tion 12 of the garment 10, thereby providing a neat appearing garment in which the open crotch 42 will be normally closed and retained in a neat condition.

The present invention provides a garment which is an effective cover for the diaper and rubber pants, but yet permits easy access thereto for replacement. The straight cut forming the edges of the open crotch permit the device to be more readily formed and constructed, thereby enhancing the economic feasibility thereof. The separate gusset 36 or gore provides sufficient slack to permit removal of the infant's legs and may be constructed of knitted fabric which permits the entire garment to be formed having slimmer and neater lines than a garment made of woven fabric, although it will be understood that a woven fabric may be utilized without changing the principles of the invention. Also, it will be understood that the snap fastener elements 46 are entirely optional and may or may not be provided on the device.

In a garment constructed of woven fabric, it would be more feasible to provide a tubular edge for the open crotch with an inserted elastic member therein wherein the entire edge of the open crotch would be provided with gathers when in a closed position. While the woven fabric is not specifically illustrated, it will be clearly understood that the principles of the present invention would be utilized in the garment regardless of the type of material utilized therein and regardless of the particular configuration of the upper portion of the garment. The elasticized open crotch provides a neat appearing garment which completely covers the diaper and rubber pants when the infant or small child is at work or play but yet permits the easy removal and replacement of a diaper without complete removal of the garment, thereby providing a garment which will save time in changing diapers, together with the advantages inherent therefrom.

The foregoing is considered as illustrative only of the principles of the invention. Further, since numerous modifications and changes will readily occur to those skilled in the art, it is not desired to limit the invention to the exact construction and operation shown and described, and accordingly, all suitable modifications and equivalents may be resorted to, falling within the scope of the appended claim.

What is claimed as new is as follows:

A garment for a diaper-wearing infant comprising a main body for enclosing the lower portion of the body and the legs of an infant, said main body including a waist encircling portion, a hip region enclosing portion, and elongated tubular members extending from the hip

4

region enclosing portion for substantially completely enclosing the legs of an infant, each of said tubular members including an enlarged generally triangular gusset forming the inner upper portion thereof, the converging edges of the gussets extending downwardly, the base edge of the gussets being adjacent each other and being free from each other and longer than the distance from the front to rear of the hip enclosing region and longer than the distance between the inner ends of the gusset receiving area of the tubular members thus forming an enlarged crotch opening between the tubular leg enclosing members and extending from the front to the rear of the hip region enclosing portion, the elongation of the base edges of the gussets providing a fullness permitting the free edge of each of the gussets to be pulled outwardly along the inner surface of the leg of an infant sufficient distance for permitting the leg and foot of the infant to be withdrawn through the outer end of the tubular leg enclosing member by flexing the leg of the infant at the hip and knee joint and subsequently permitting the leg and foot of the infant to be projected through the crotch opening between the base edges of the gussets, the length of the free edges of the gussets being sufficient to permit the infant's legs and hip region to be projected through the crotch opening after both legs have been withdrawn from the leg enclosing tubular member and projected through the crotch opening, the edges of the crotch opening adapted to encircle the waist of the infant above the diaper region after both legs have been withdrawn from the tubular members and projected through the crotch opening thereby providing access to the diaper region for facilitating the changing of a diaper, the free edge of each gusset having a resilient band thereon for gathering the fullness to conform the tubular leg enclosing members to the legs of the infant and for urging the base edges of the gussets inwardly into the crotch region of the infant thereby disposing the edges of the crotch opening in adjacent relation thereby closing the crotch opening.

References Cited in the file of this patent  
UNITED STATES PATENTS

872,172	Elterich	Nov. 26, 1907
1,175,514	Fox	Mar. 14, 1927
1,643,980	Carlson et al.	Oct. 4, 1927
2,132,610	Ellinger	Oct. 11, 1938
2,476,585	Cohen	July 19, 1949
2,679,049	Daniels	May 25, 1954
2,689,958	Gray	Sept. 28, 1954