



US00D776719S

(12) **United States Design Patent**
Fisher et al.

(10) **Patent No.:** **US D776,719 S**

(45) **Date of Patent:** **** Jan. 17, 2017**

(54) **HYDRAULIC POWER UNIT HAVING FILL PORT**

(71) Applicant: **Eaton Corporation**, Cleveland, OH (US)

(72) Inventors: **Daniel P. Fisher**, Coldwater, MI (US); **Andrew N. Edler**, Homer, MI (US); **Scott M. Besemer**, Battle Creek, MI (US); **Jeffrey A. Oesch**, Roseville, MI (US); **Matthew G. Fox**, Ceresco, MI (US)

(73) Assignee: **Eaton Corporation**, Cleveland, OH (US)

(**) Term: **15 Years**

(21) Appl. No.: **29/561,207**

(22) Filed: **Apr. 14, 2016**

Related U.S. Application Data

(63) Continuation-in-part of application No. 29/549,910, filed on Dec. 29, 2015, which is a continuation-in-part of application No. 29/508,563, filed on Nov. 7, 2014.

(51) **LOC (10) Cl.** **15-01**

(52) **U.S. Cl.**
USPC **D15/5**

(58) **Field of Classification Search**
USPC D15/5, 7, 8, 9, 148, 149, 199; 475/226, 475/220, 149, 150, 151, 152, 153, 154, 475/249, 248, 231; D23/231, 232; D12/160, 159; 418/61.3; 180/65.235; 60/426
CPC F15B 11/162; F15B 11/26; F15B 13/044; F15B 13/026; F15B 2211/781; F16H 39/40

See application file for complete search history.

(56) **References Cited**

U.S. PATENT DOCUMENTS

D308,209 S *	5/1990	Laqua	D15/7
7,857,723 B2 *	12/2010	Krisher	B60K 17/20
			475/150
7,891,730 B2 *	2/2011	Rikkert	B60J 7/0573
			296/220.01
7,985,162 B2 *	7/2011	Buchele	B64G 1/286
			475/150
D741,916 S *	10/2015	Fox	D15/5
D744,542 S *	12/2015	Edler	D15/7
D749,642 S *	2/2016	Fisher	D15/5
2008/0042488 A1 *	2/2008	Anderson	B60T 8/323
			303/10

(Continued)

Primary Examiner — T. Chase Nelson

Assistant Examiner — Ania Aman

(74) *Attorney, Agent, or Firm* — Remarck Law Group PLC

(57) **CLAIM**

The ornamental design for a hydraulic power unit having fill port, as shown and described.

DESCRIPTION

FIG. 1 is a front perspective view of the hydraulic power unit having fill port showing the new design.

FIG. 2 is a top plan view of the hydraulic power unit having fill port.

FIG. 3 is a bottom plan view of the hydraulic power unit having fill port.

FIG. 4 is a first side view of the hydraulic power unit having fill port.

FIG. 5 is a second side view of the hydraulic power unit having fill port.

FIG. 6 is a third side view of the hydraulic power unit having fill port; and,

FIG. 7 is a fourth side view of the hydraulic power unit having fill port.

(Continued)

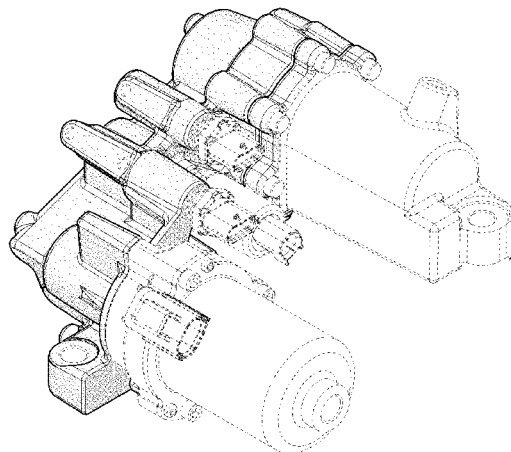

The broken line showing portions of the hydraulic power unit having fill port form no part of the claimed design.

1 Claim, 7 Drawing Sheets

(56)

References Cited

U.S. PATENT DOCUMENTS

2008/0060867	A1*	3/2008	Oda	B60K 5/04 180/291
2008/0085803	A1*	4/2008	Claussen	B60K 17/36 475/220
2010/0218746	A1*	9/2010	Rabhi	F16K 11/161 123/48 B
2011/0147111	A1*	6/2011	Sun	B62D 5/0406 180/444
2012/0329592	A1*	12/2012	Sun	B62D 5/0406 475/4
2014/0179484	A1*	6/2014	Fox	F16H 48/32 475/231
2014/0274529	A1*	9/2014	Edler	F16H 48/22 475/150
2015/0105210	A1*	4/2015	Wadhva	F16H 48/08 475/232
2016/0076634	A1*	3/2016	Mitsubori	F16H 57/0006 74/325
2016/0091077	A1*	3/2016	Sotani	F16H 57/021 74/606 R

* cited by examiner

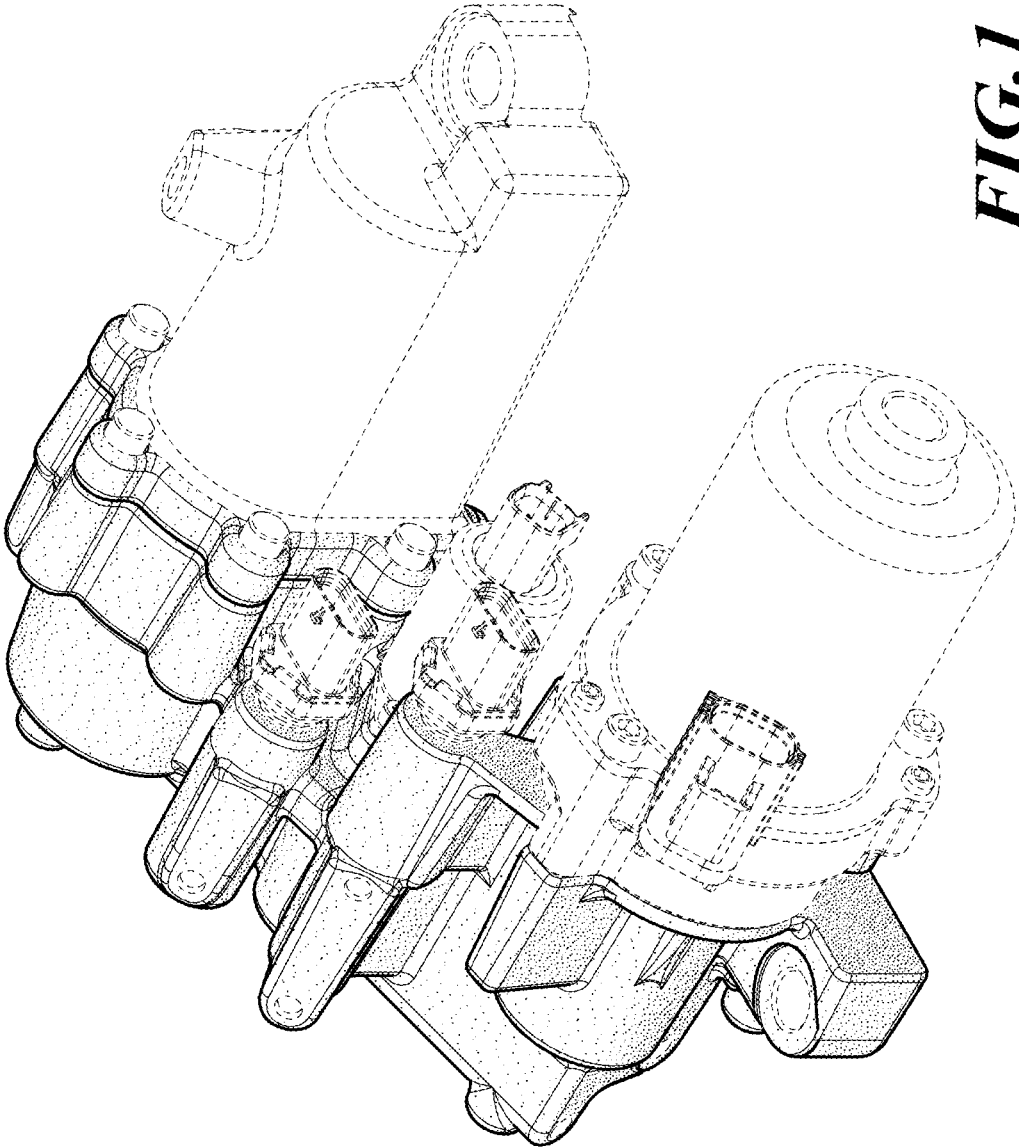

FIG. 1

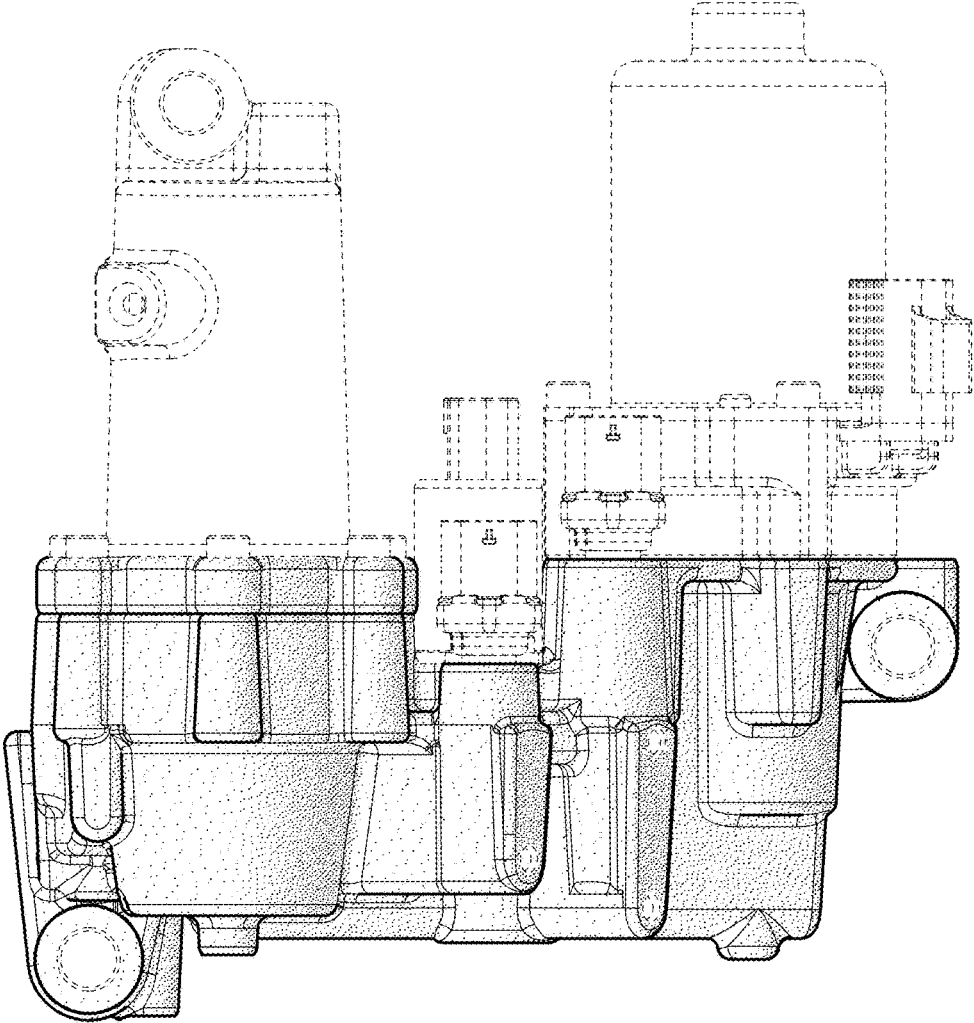

FIG. 2

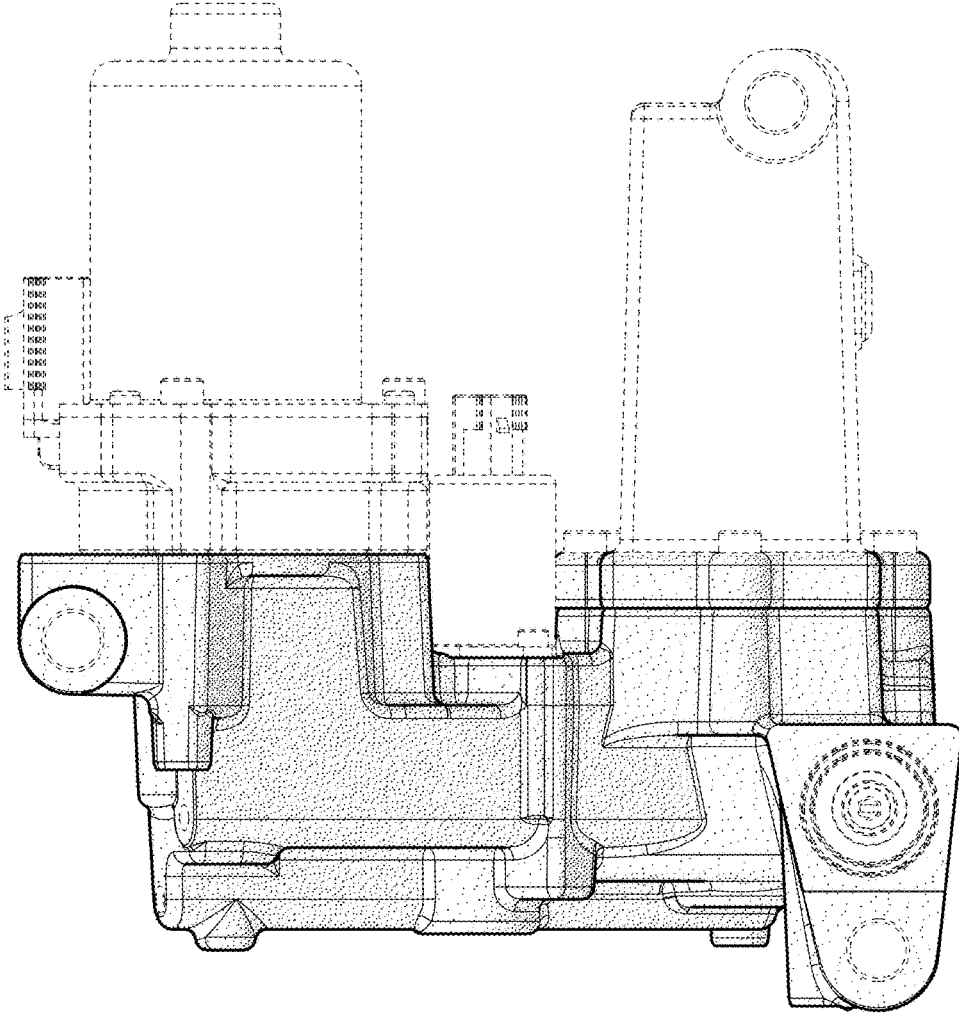

FIG. 3

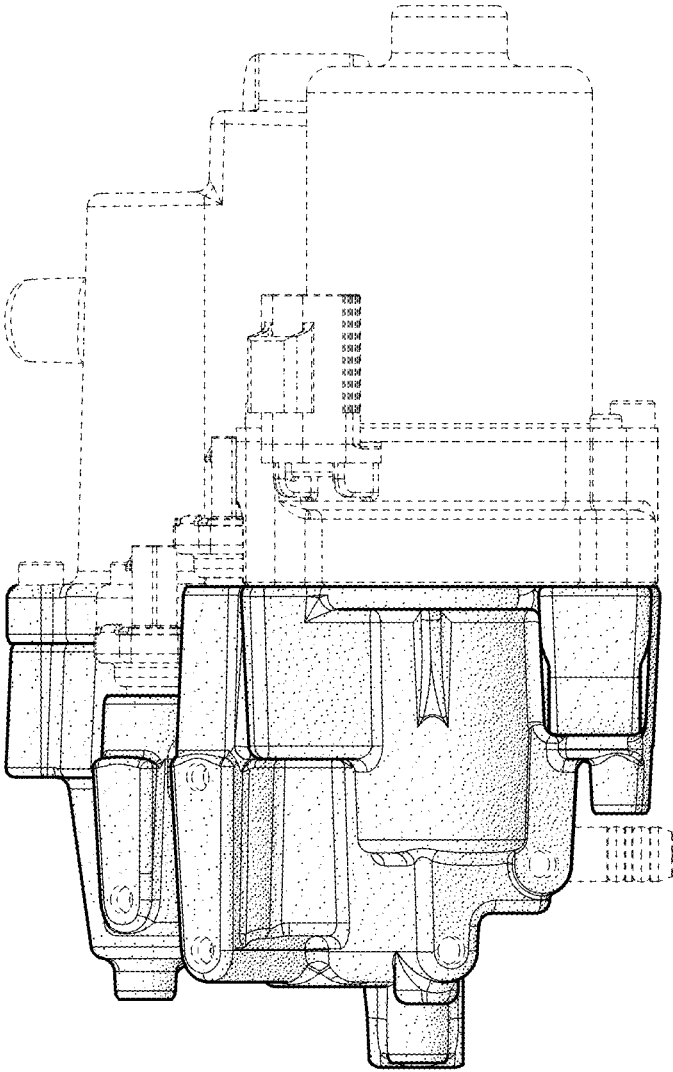

FIG. 4

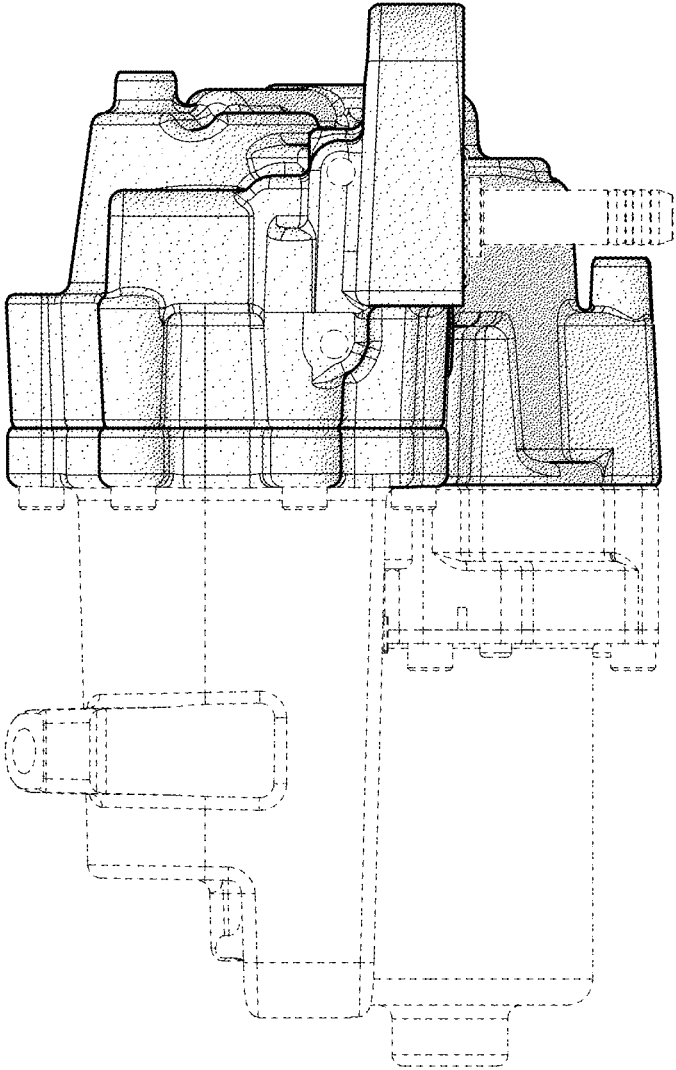

FIG. 5

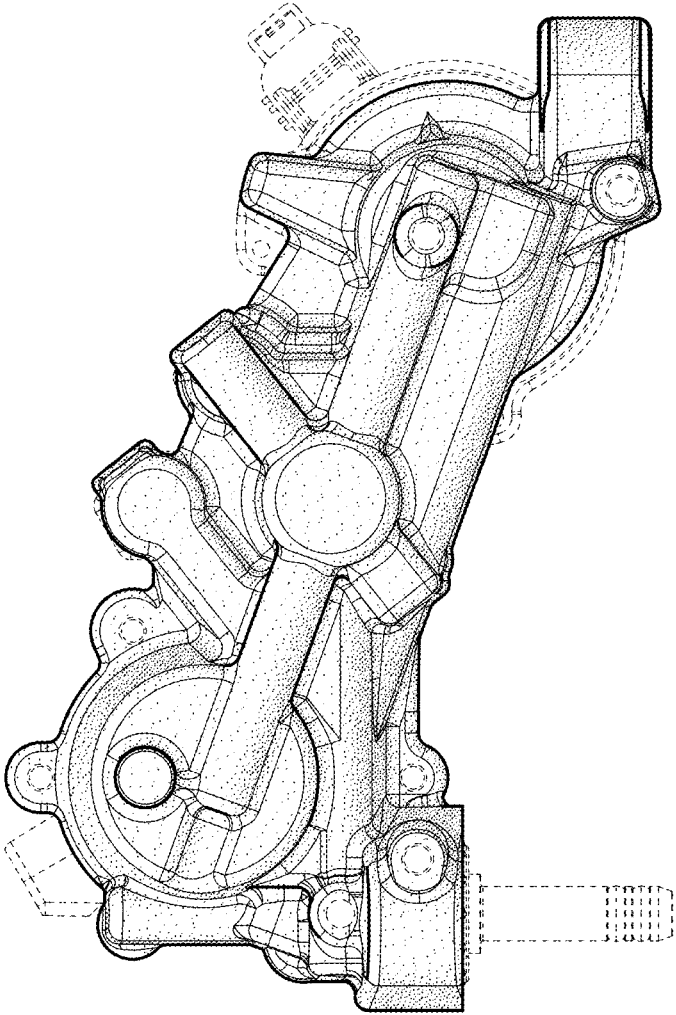

FIG. 6

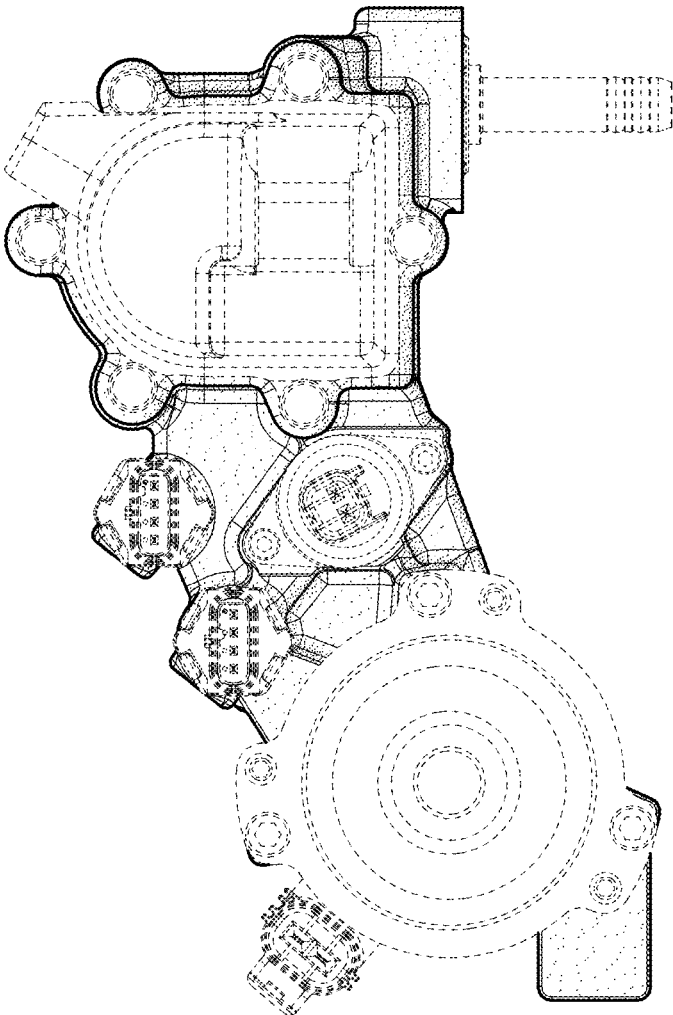

FIG. 7