



US00D871926S

(12) **United States Design Patent**
Tayara

(10) **Patent No.:** **US D871,926 S**

(45) **Date of Patent:** **** Jan. 7, 2020**

(54) **EGG CARTON**

B65D 85/324; B65D 85/32; B65D 71/70;
B65D 85/322; B65D 25/04

(71) Applicant: **Global Plastics, Inc.**, Perris, CA (US)

See application file for complete search history.

(72) Inventor: **Tarek Tayara**, Perris, CA (US)

(56) **References Cited**

(73) Assignee: **GLOBAL PLASTICS, INC.**, Perris, CA (US)

U.S. PATENT DOCUMENTS

(**) Term: **15 Years**

(21) Appl. No.: **29/664,484**

(22) Filed: **Sep. 25, 2018**

Related U.S. Application Data

(60) Continuation-in-part of application No. 29/659,470, filed on Aug. 9, 2018, now Pat. No. Des. 851,502, which is a continuation-in-part of application No. 29/628,548, filed on Dec. 5, 2017, now Pat. No. Des. 853,859, which is a division of application No. 29/586,659, filed on Dec. 6, 2016, now Pat. No. Des. 804,324.

(51) **LOC (12) CL.** **09-03**

(52) **U.S. Cl.**
USPC **D9/757; D9/762**

(58) **Field of Classification Search**
USPC D9/762, 757, 737, 761, 420-426, 432, D9/418, 415, 501, 72, 739, 742, 753, 756, D9/741, 721, 434, 443, 499; D7/611, D7/550.1, 605, 701, 553.1, 553.2, 614; D3/313, 304, 311, 314, 315; D24/227; 206/139, 201-203, 427, 265, 504, 518, 206/519, 524.1, 557, 561, 564, 565, 703, 206/704, 705, 523, 586, 515, 521.1, 206/521.15, 521.3, 521.6, 521.8, 521.4, 206/521.9, 406; 220/4.26, 508; 209/406; D11/143, 155, 156
CPC B65D 5/5495; B65D 85/1072; B65D 5/5253; B65D 85/1063; B65D 5/0085; B65D 21/0204; B65D 5/427; B65D 21/0201; B65D 5/009; B65D 77/006;

2,285,129	A	6/1942	Schwartzberg
2,455,295	A	11/1948	Cox
2,560,847	A	7/1951	Chaplin
2,591,446	A	4/1952	Lennon
D197,031	S	12/1963	Reifers
D197,093	S	12/1963	Reifers
3,131,846	A	5/1964	Whiteford
3,144,972	A	8/1964	Hartmann et al.
3,257,062	A	6/1966	Whiteford
3,362,605	A	1/1968	Bixler
3,421,682	A	1/1969	Eisenbach
3,458,108	A	7/1969	Howarth et al.
3,471,078	A	10/1969	Seest et al.
3,603,499	A	9/1971	Snow
3,645,436	A	2/1972	Boyd et al.
3,661,317	A	5/1972	Noguchi
3,664,574	A	5/1972	Pearl et al.
3,672,693	A	6/1972	Weir
3,771,712	A	11/1973	Richards
3,779,370	A	12/1973	Snow et al.
3,813,027	A	5/1974	Misdom, Jr. et al.
3,908,891	A	9/1975	Jackson
4,025,038	A	5/1977	Reifers et al.
4,057,188	A	11/1977	Steinhardt
4,059,219	A	11/1977	Reifers et al.
4,161,382	A	7/1979	Padovani
4,205,777	A	6/1980	Brown et al.
D266,225	S	9/1982	Villotte
4,352,427	A	10/1982	Lake
D273,844	S	5/1984	Bixler et al.
4,448,344	A	5/1984	Lord et al.
D274,790	S	7/1984	Bixler et al.
4,492,331	A	1/1985	Bixler et al.
D284,226	S	6/1986	Sussman
4,609,141	A	9/1986	Lake
4,625,905	A	12/1986	Mangla
4,657,173	A	4/1987	Lake
D291,533	S	8/1987	Mangla
4,742,953	A	5/1988	Jacobs et al.
4,795,080	A	1/1989	McIntyre
D305,405	S	1/1990	Wilkinson
D306,138	S	2/1990	Congleton et al.
5,102,034	A	4/1992	Amabili
5,927,501	A	7/1999	Herbruck
6,012,583	A	1/2000	Ramirez

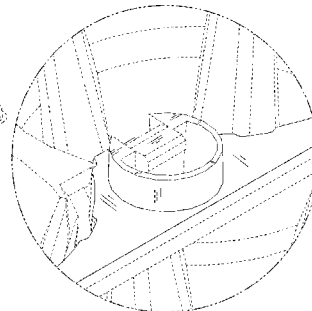
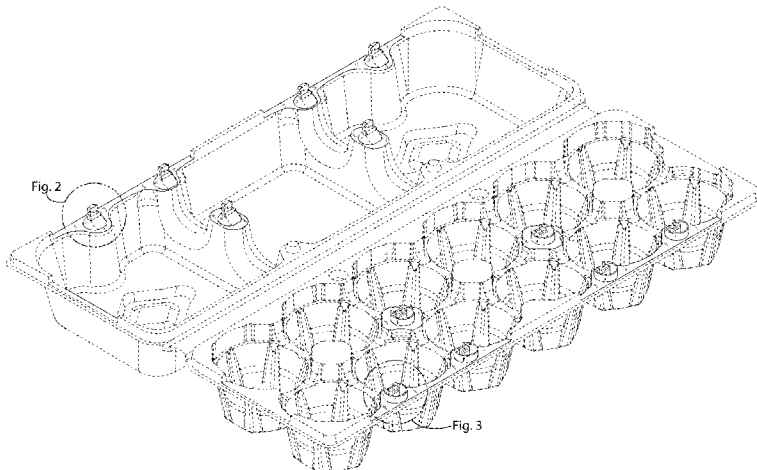

D428,332	S	7/2000	Knutson	
D466,802	S	12/2002	Davkovski	
D514,452	S	2/2006	Enriquez	
D520,377	S	5/2006	Beese et al.	
7,255,231	B2	8/2007	Andrews et al.	
7,353,951	B2	4/2008	Vovan	
D592,076	S	5/2009	Sipe et al.	
D592,077	S	5/2009	Sipe et al.	
7,686,181	B2	3/2010	St-Onge	
D616,267	S	5/2010	Kulzer	
D616,270	S	5/2010	Kulzer	
D616,714	S	6/2010	Kulzer	
D619,860	S	7/2010	Kulzer	
7,766,169	B2	8/2010	St-Onge	
D632,974	S	2/2011	Dijkstra et al.	
D632,975	S	2/2011	Dijkstra	
D632,976	S	2/2011	Dijkstra et al.	
D632,977	S	2/2011	Dijkstra et al.	
D656,843	S	4/2012	Schleining	
D661,601	S	6/2012	Sanfilippo	
D689,376	S	9/2013	Von der Ahe	
8,695,803	B2	4/2014	Blanchette et al.	
8,844,721	B2	9/2014	Archambault et al.	
8,863,955	B2	10/2014	St-Onge	
D735,585	S	8/2015	Tayara	
D739,265	S	9/2015	Buckley et al.	
D739,767	S	9/2015	Schleining	
9,169,058	B1	10/2015	Ramirez et al.	
9,340,343	B2	5/2016	Ramirez et al.	
9,340,349	B2	5/2016	Ramirez et al.	
9,340,350	B2	5/2016	Kuruvilla et al.	
D758,916	S	6/2016	Davis	
D761,127	S	7/2016	Sellari et al.	
9,382,056	B1	7/2016	Hanna	
D766,663	S	9/2016	Bergeron et al.	
D778,176	S *	2/2017	Long	D9/757
9,617,060	B1 *	4/2017	Hanna	B65D 81/28
D792,277	S *	7/2017	Davis	D11/143
D795,084	S	8/2017	Schleining	
D802,444	S	11/2017	Schleining	
D804,324	S	12/2017	Tayara	
D804,965	S *	12/2017	Schleining	D9/762
D834,952	S *	12/2018	Kuruvilla	D9/757
D851,502	S *	6/2019	Tayara	D9/762
D853,859	S *	7/2019	Tayara	D9/757
2005/0178689	A1	8/2005	Aardema et al.	
2006/0060493	A1	3/2006	Marshall	
2007/0138177	A1	6/2007	Vovan	
2007/0151892	A1 *	7/2007	St-Onge	B65D 85/32 206/521.1
2007/0256954	A1 *	11/2007	Vovan	B65D 71/70 206/521.1
2008/0283437	A1 *	11/2008	St-Onge	B65D 85/32 206/521.1
2010/0187150	A1	7/2010	Dijkstra et al.	
2011/0132791	A1	6/2011	Dijkstra et al.	
2011/0233100	A1	9/2011	Attard	
2013/0020224	A1	1/2013	Ramirez et al.	
2013/0048527	A1	2/2013	Ramirez et al.	
2013/0048528	A1	2/2013	Ramirez et al.	
2013/0126384	A1	5/2013	Ogg	
2013/0183412	A1 *	7/2013	Ramirez	B65D 77/0413 426/119
2013/0264243	A1 *	10/2013	Aardema	B65D 85/32 206/521.1
2016/0046432	A1 *	2/2016	Kuruvilla	B65D 85/32 206/521.1
2016/0257485	A1	9/2016	Ramirez et al.	
2018/0273284	A1 *	9/2018	Bergeron	B65D 85/32

FOREIGN PATENT DOCUMENTS

EP	119043	9/1984
JP	4729091	7/2011
JP	2016204029	12/2016
WO	2012010992	1/2012

* cited by examiner

Primary Examiner — W. A. Teddy Falloway
(74) Attorney, Agent, or Firm — Cislo & Thomas, LLP

(57) CLAIM

The ornamental design for an egg carton, as shown and described.

DESCRIPTION

FIG. 1 is a perspective top view of my egg carton in an open configuration;
 FIG. 2 is a close-up of the portion indicated as 2 in FIG. 1, which is a top view of one of the lock components, which is the same appearance for each lock component;
 FIG. 3 is a close-up of the portion indicated as 3 in FIG. 1, which is a top view of one of the lock receiving components for receiving one of the lock components, which is the same for each lock receiving component;
 FIG. 4 is a perspective bottom view of the embodiment shown in FIG. 1;
 FIG. 5 is a close-up of the portion indicated as 5 in FIG. 4, which is a bottom perspective view of one of the lock components, which is the same for each lock component;
 FIG. 6 is a top view of the embodiment shown in FIG. 1;
 FIG. 7 is a close-up of the portion indicated as 7 in FIG. 6, which is a top view of one of the cups, which is the same for each cup;
 FIG. 8 is a close-up of the portion indicated as 8 in FIG. 6, which is a top view of one of the lock components, which is the same for each lock component;
 FIG. 9 is a close-up of the portion indicated as 9 in FIG. 6, which is a top view of one of the lock receiving components, which is the same for each lock receiving component;
 FIG. 10 is a bottom view of the embodiment shown in FIG. 1;
 FIG. 11 is a front elevation view thereof;
 FIG. 12 is a close-up of the portion indicated as 12 in FIG. 11, which is a front elevation view of one of the lock components, which is the same for each lock component;
 FIG. 13 is a back elevation view of the embodiment shown in FIG. 1;
 FIG. 14 is a close up of the portion indicated as 14 in FIG. 13, which is a back elevation view of one of the lock components, which is the same for each lock component;
 FIG. 15 is a first side elevation view of the embodiment shown in FIG. 1;
 FIG. 16 is a close-up of the portion indicated as 16 in FIG. 15, which is a side elevation view of one of the lock components, which is the same for each lock component;
 FIG. 17 is a second side elevation view of the embodiment shown in FIG. 1;
 FIG. 18 is a perspective top view thereof in a closed configuration;
 FIG. 19 is a close-up of the portion indicated as 19 in FIG. 18 showing a top perspective view of one lock component interlocked with one lock receiving component, which is the same for each interlocking connection;
 FIG. 20 is a perspective bottom view of the embodiment shown in FIG. 18;
 FIG. 21 is a close-up of the portion indicated as 21 in FIG. 20 showing a bottom perspective view of one lock component interlocked with one lock receiving component, which is the same for each interlocking connection;
 FIG. 22 is a top view of the embodiment shown in FIG. 18;

FIG. 23 is a close up of the portion indicated as 23 in FIG. 22 showing a top view of one lock component interlocked with one lock receiving component, which is the same for each interlocking connection;

FIG. 24 is a bottom view of the embodiment shown in FIG. 18;

FIG. 25 is a close-up of the portion indicated as 25 in FIG. 24 showing a bottom view of one of the interlocking connections, which is the same for each interlocking connection;

FIG. 26 is a front elevation view of the embodiment shown in FIG. 18;

FIG. 27 is a back elevation view thereof;

FIG. 28 is a first side elevation view thereof; and,

FIG. 29 is a second side elevation view thereof.

The broken lines shown in the drawings illustrate portions of the egg carton that form no part of the claimed design.

1 Claim, 29 Drawing Sheets

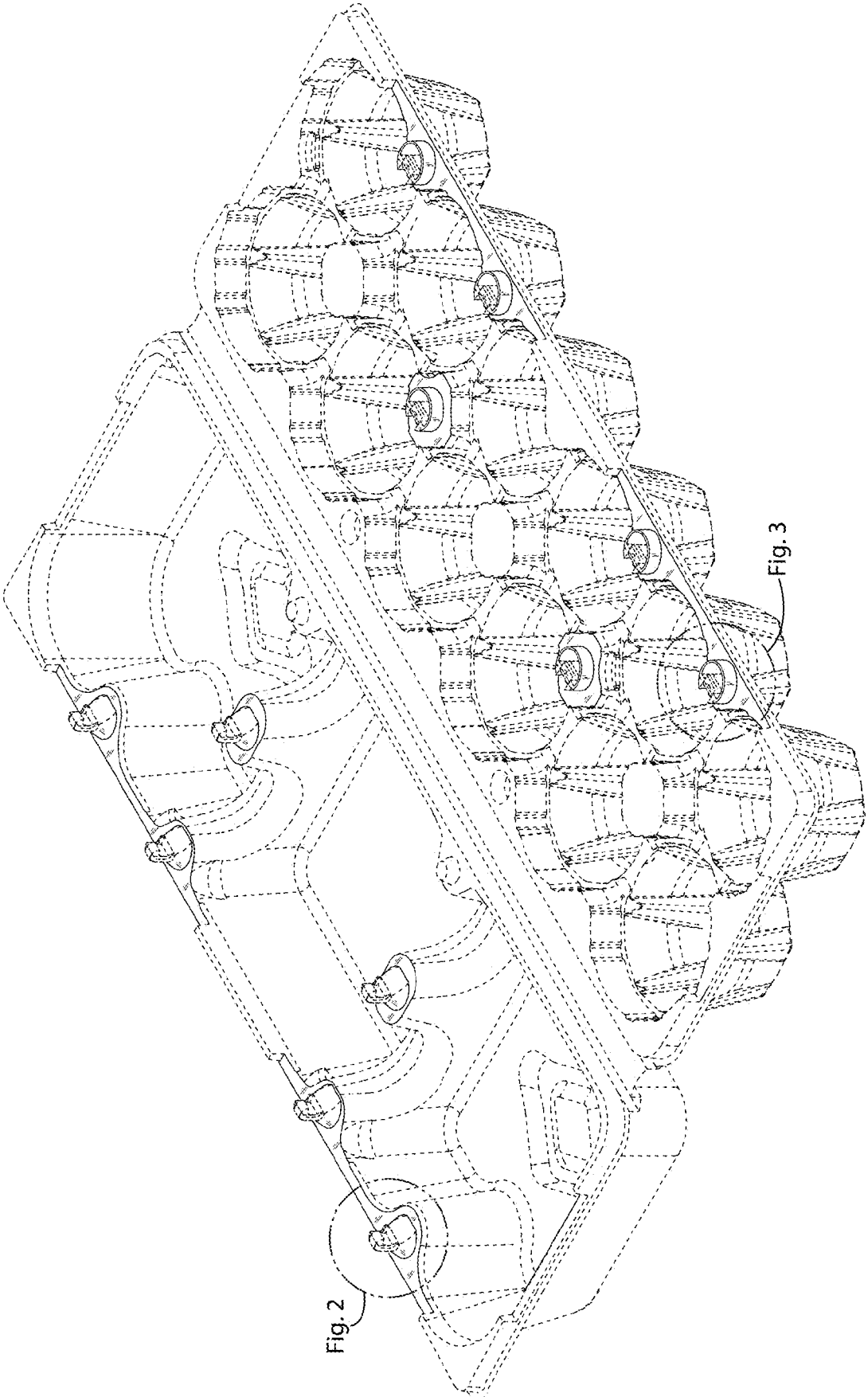

Fig. 1

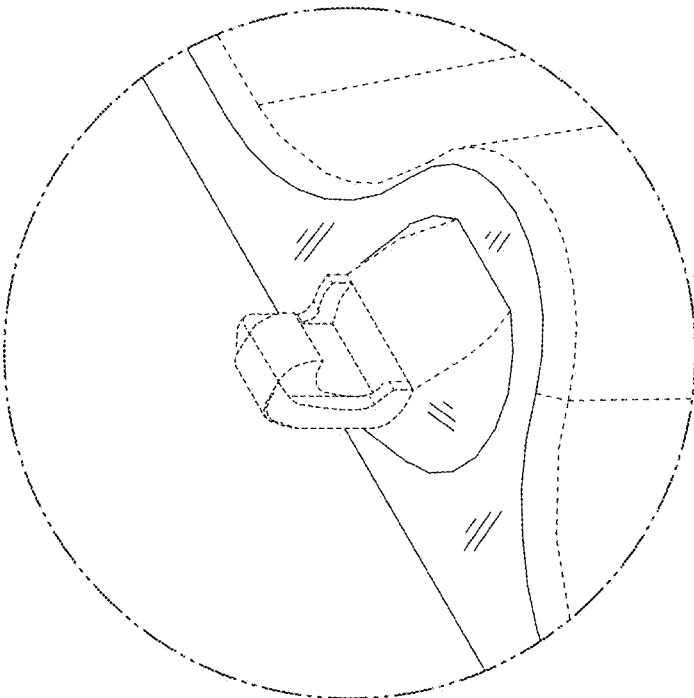

Fig. 2

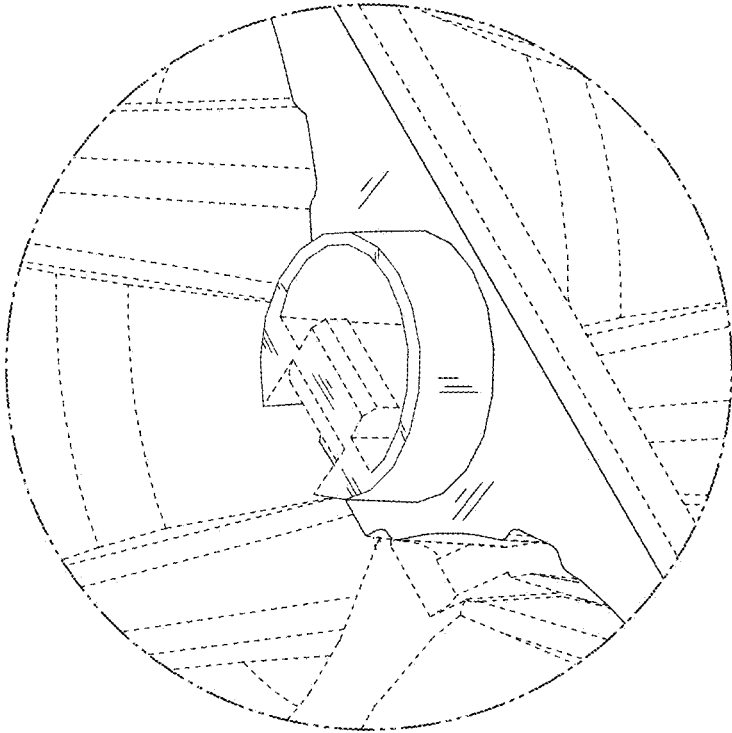

Fig. 3

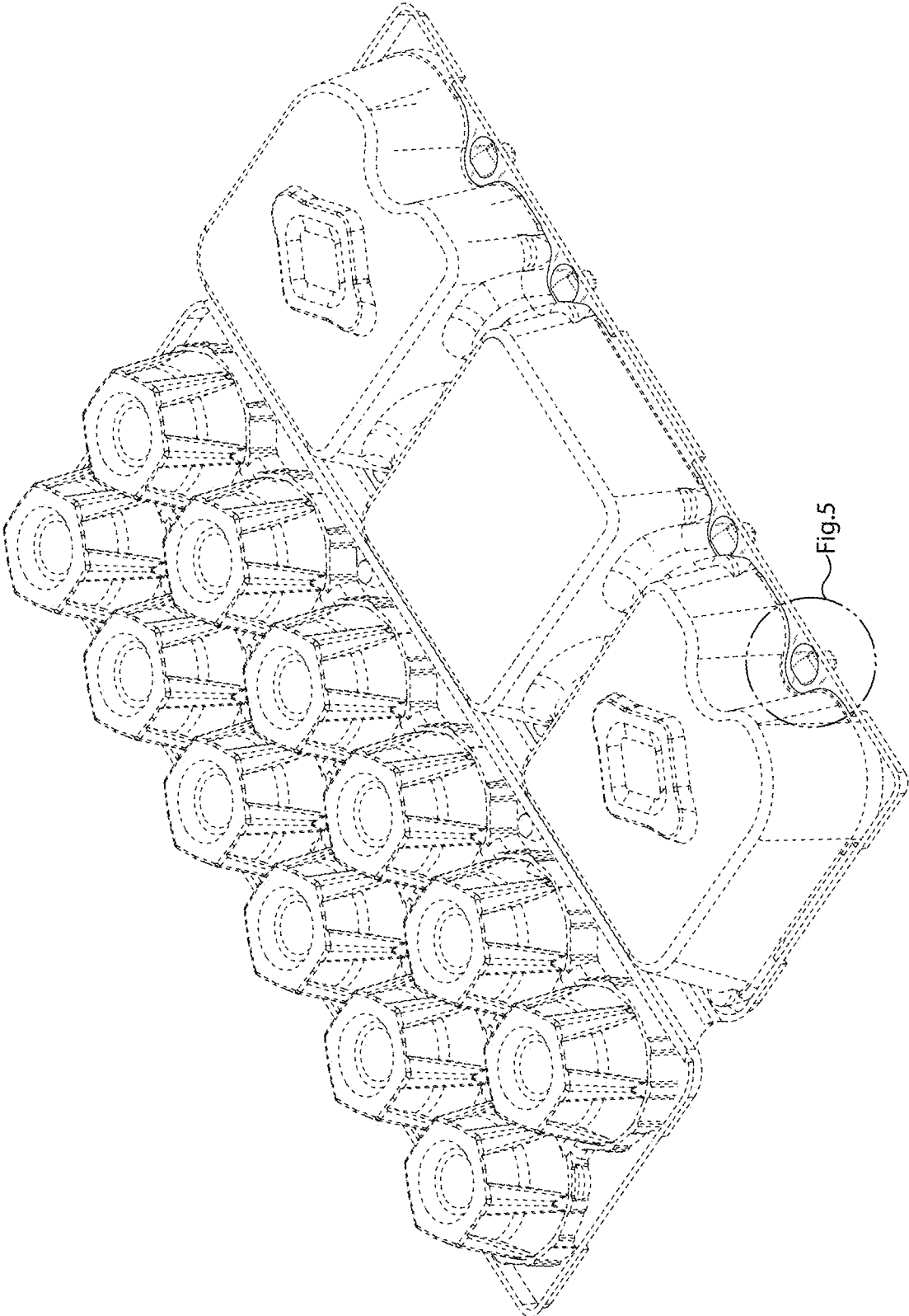

Fig. 4

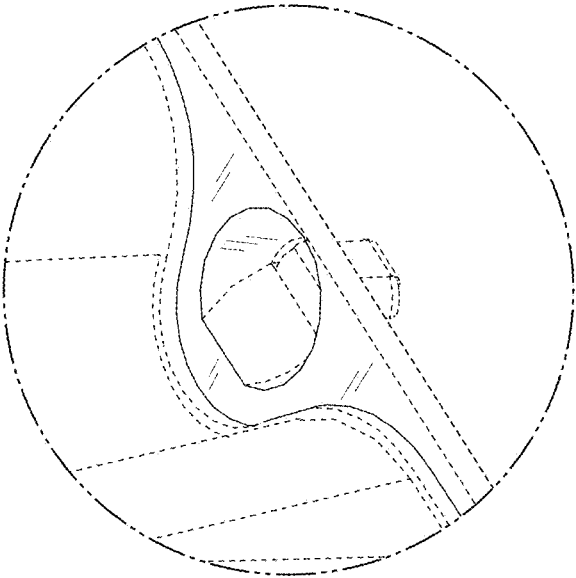

Fig. 5

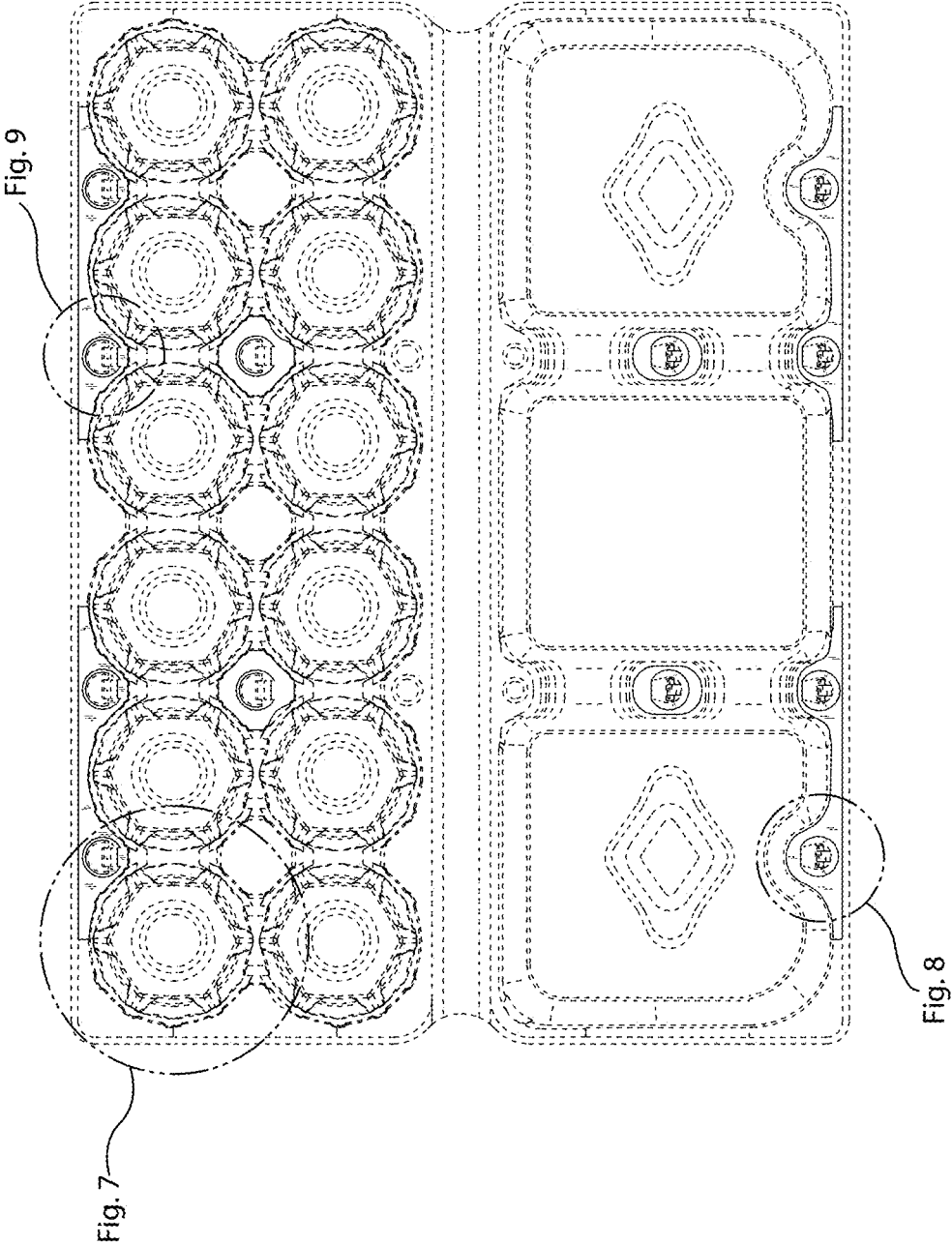

Fig. 6

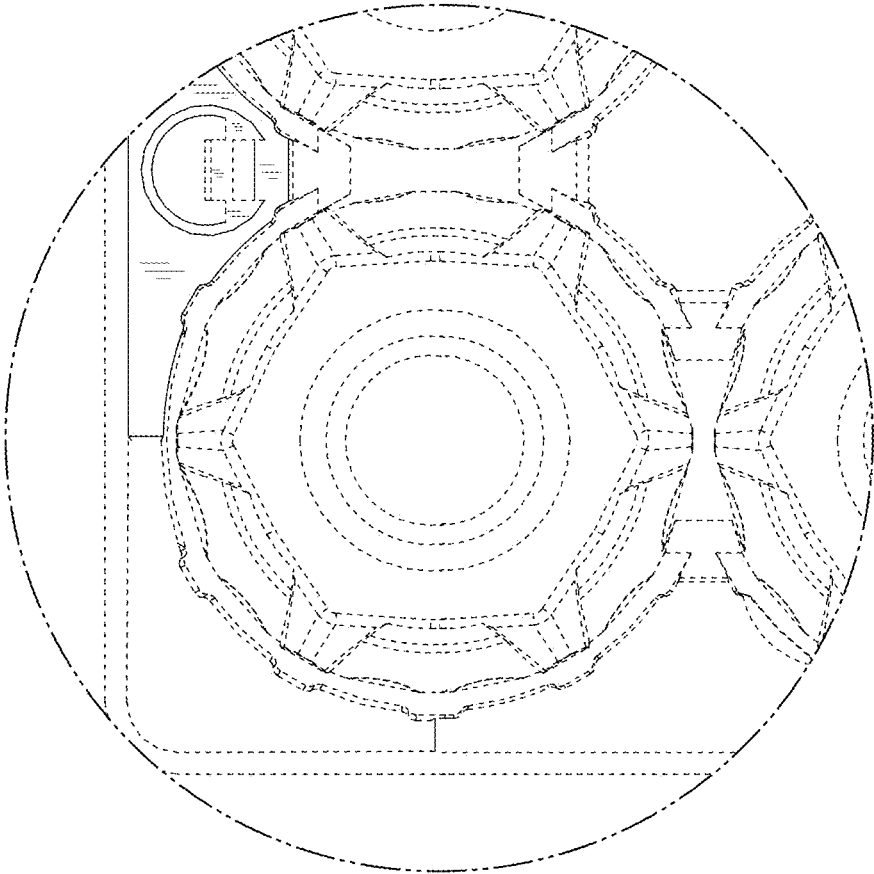

Fig. 7

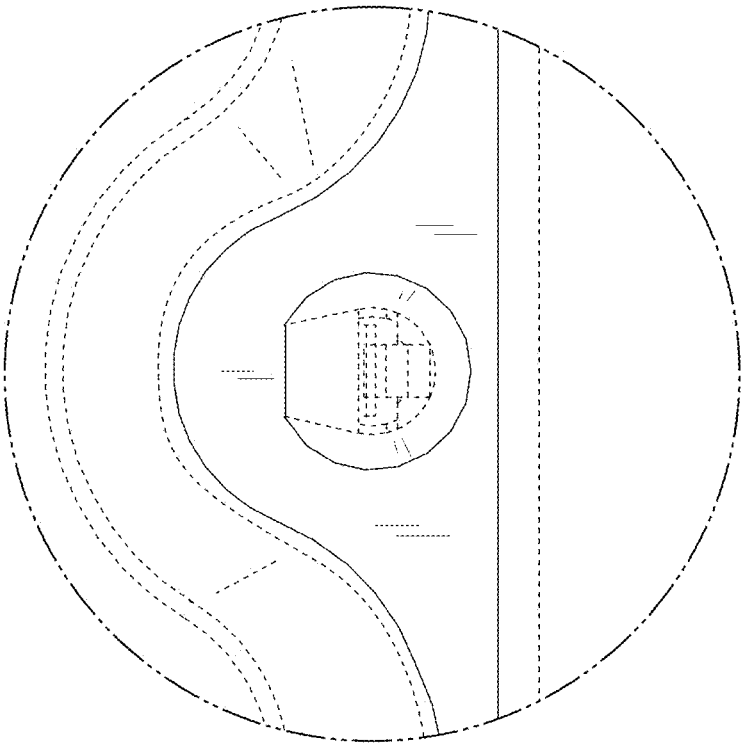

Fig. 8

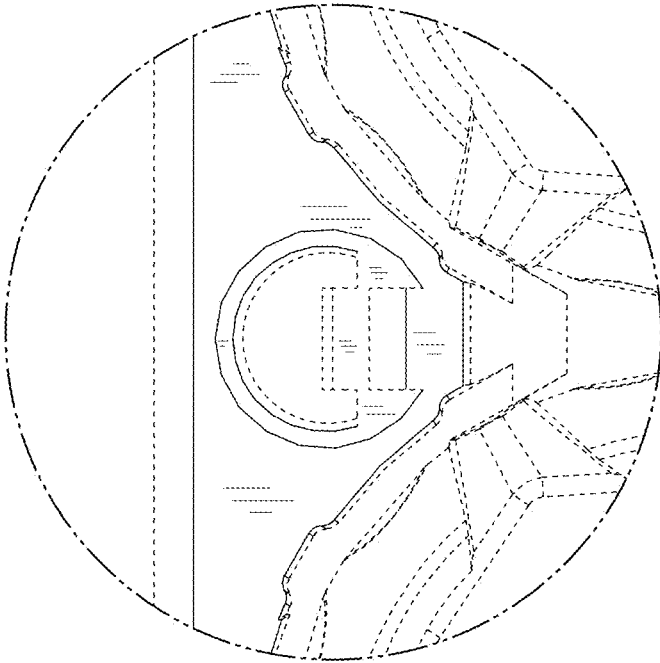

Fig. 9

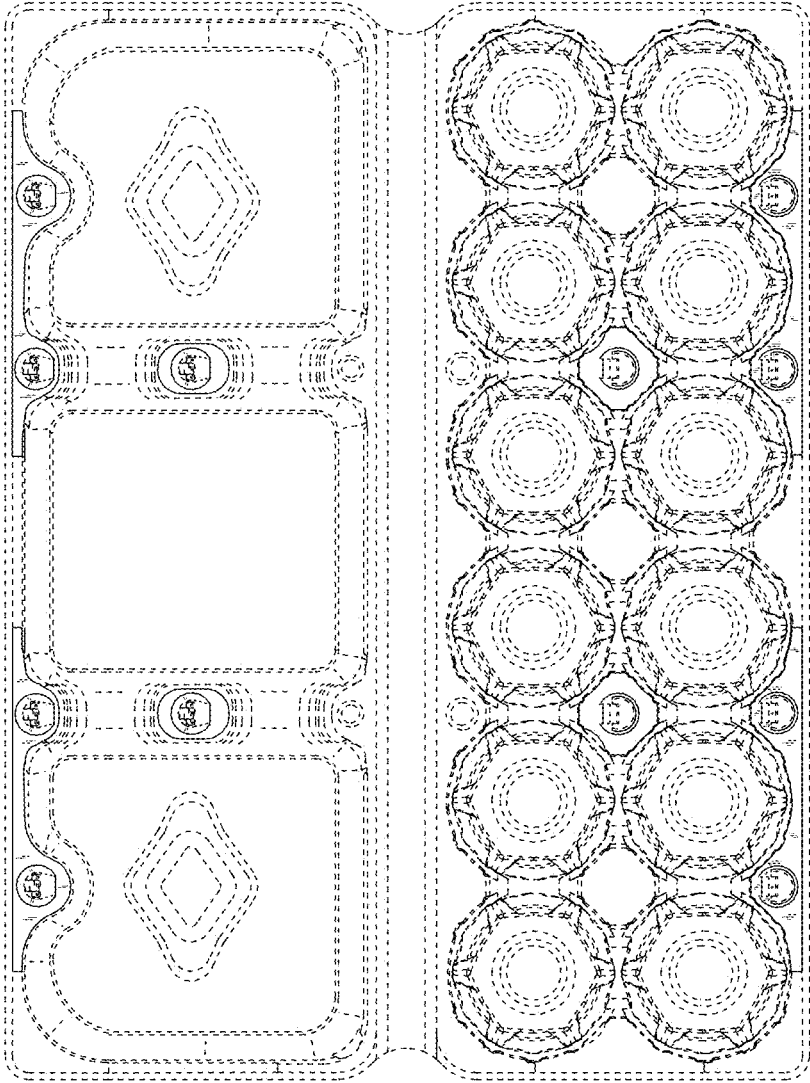

Fig. 10

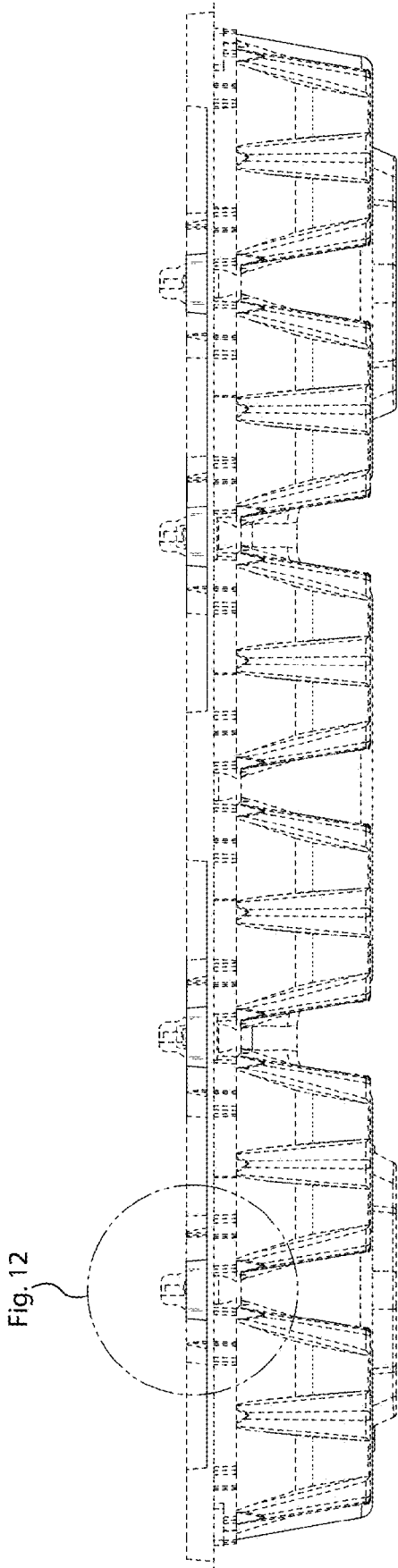

Fig. 11

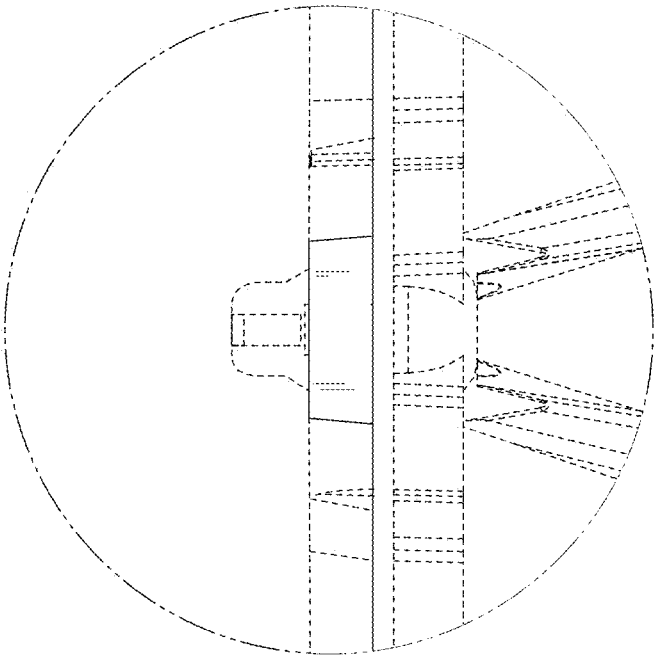

Fig. 12

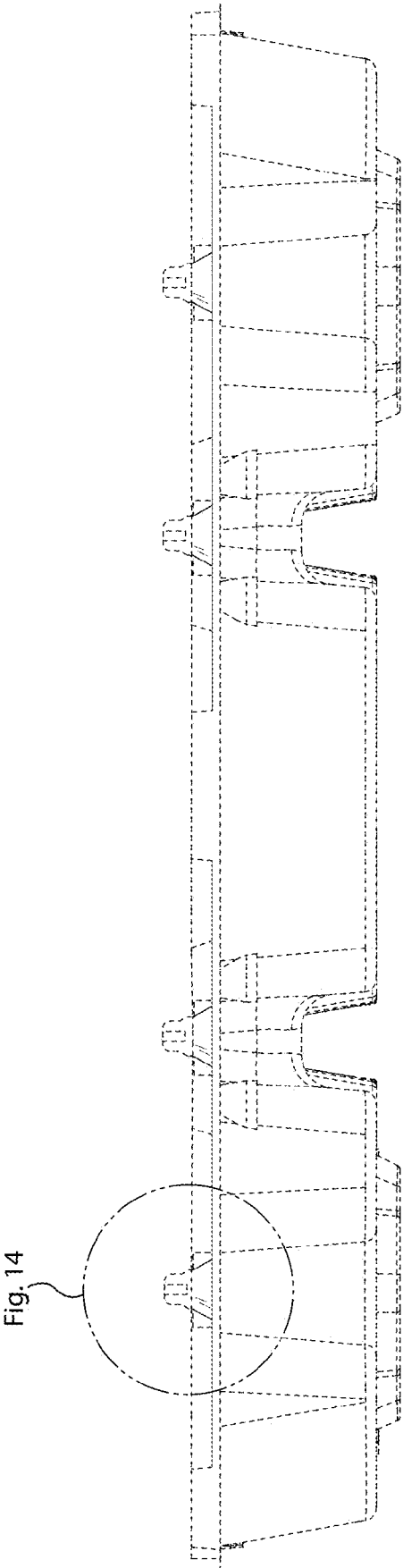

Fig. 13

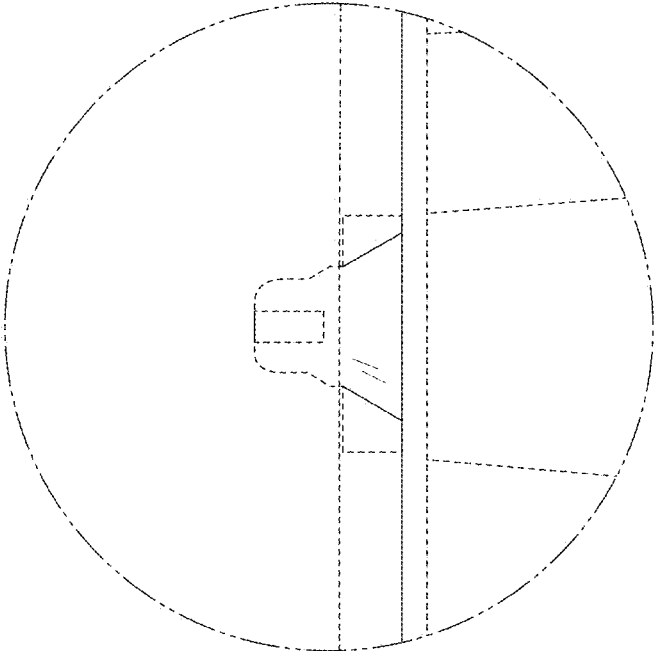

Fig. 14

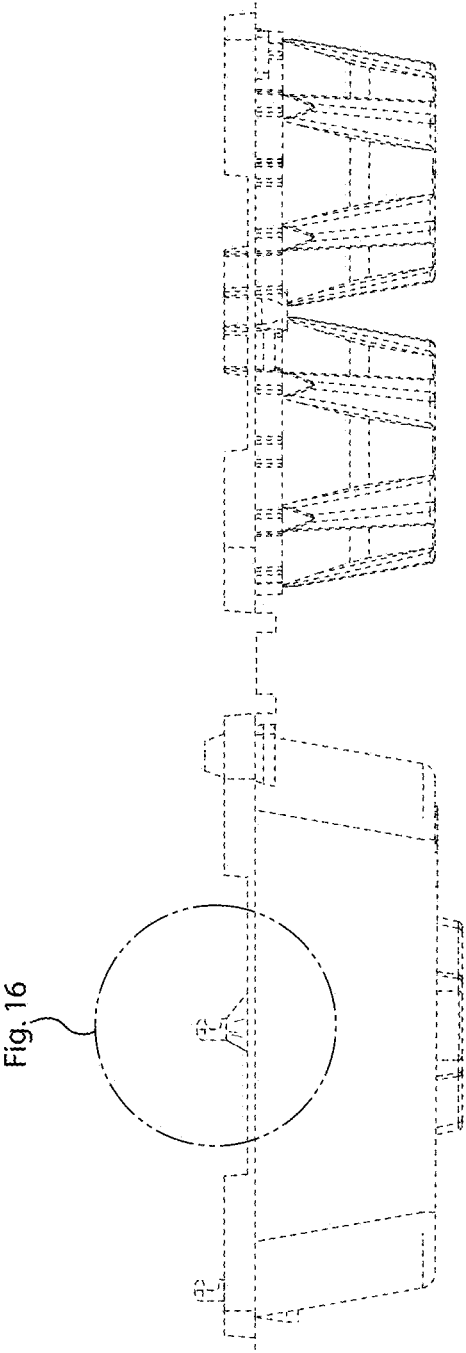

Fig. 15

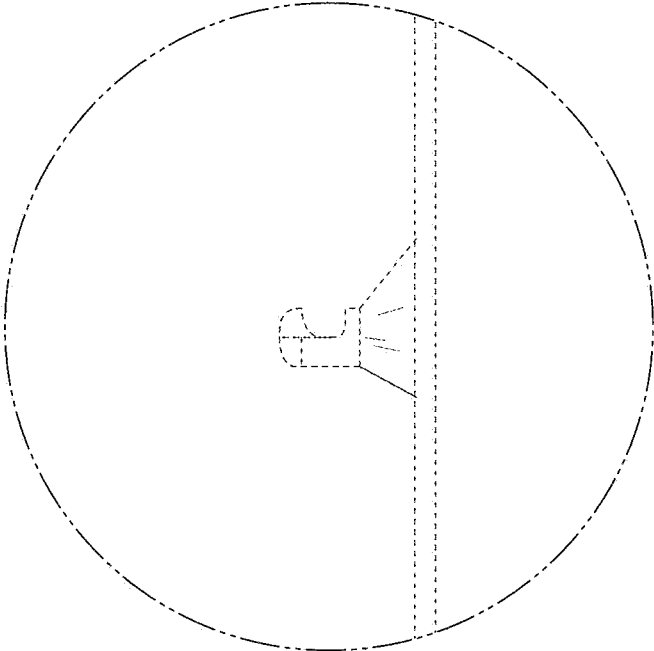

Fig. 16

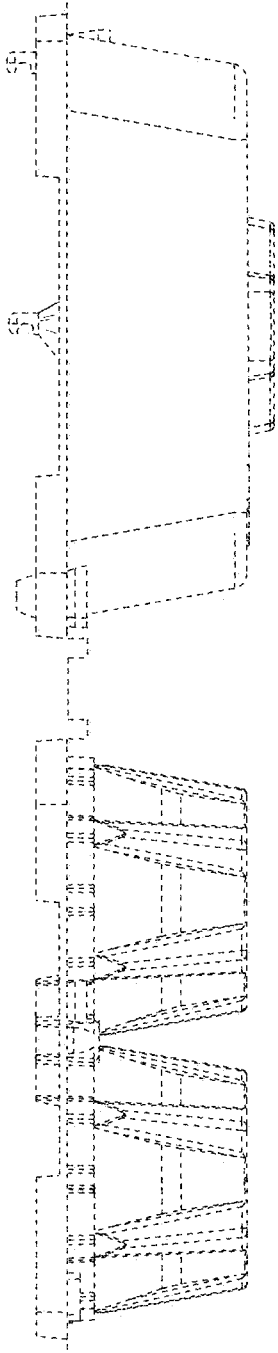

Fig. 17

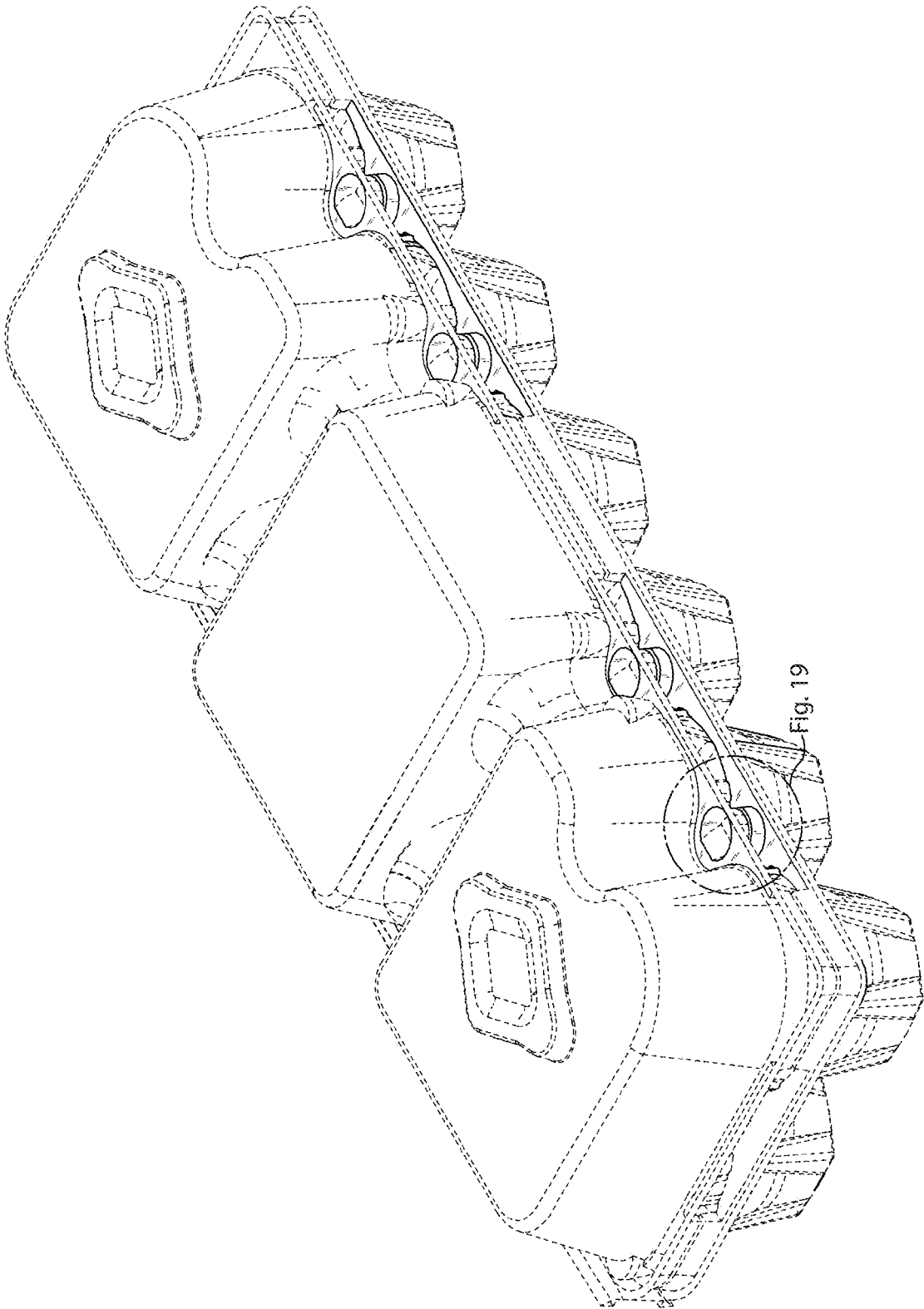

Fig. 18

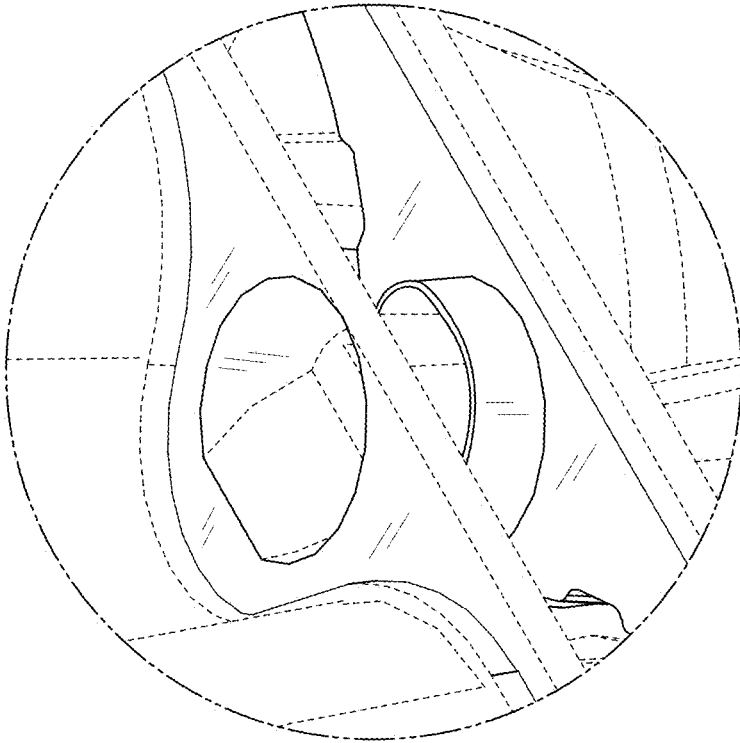

Fig. 19

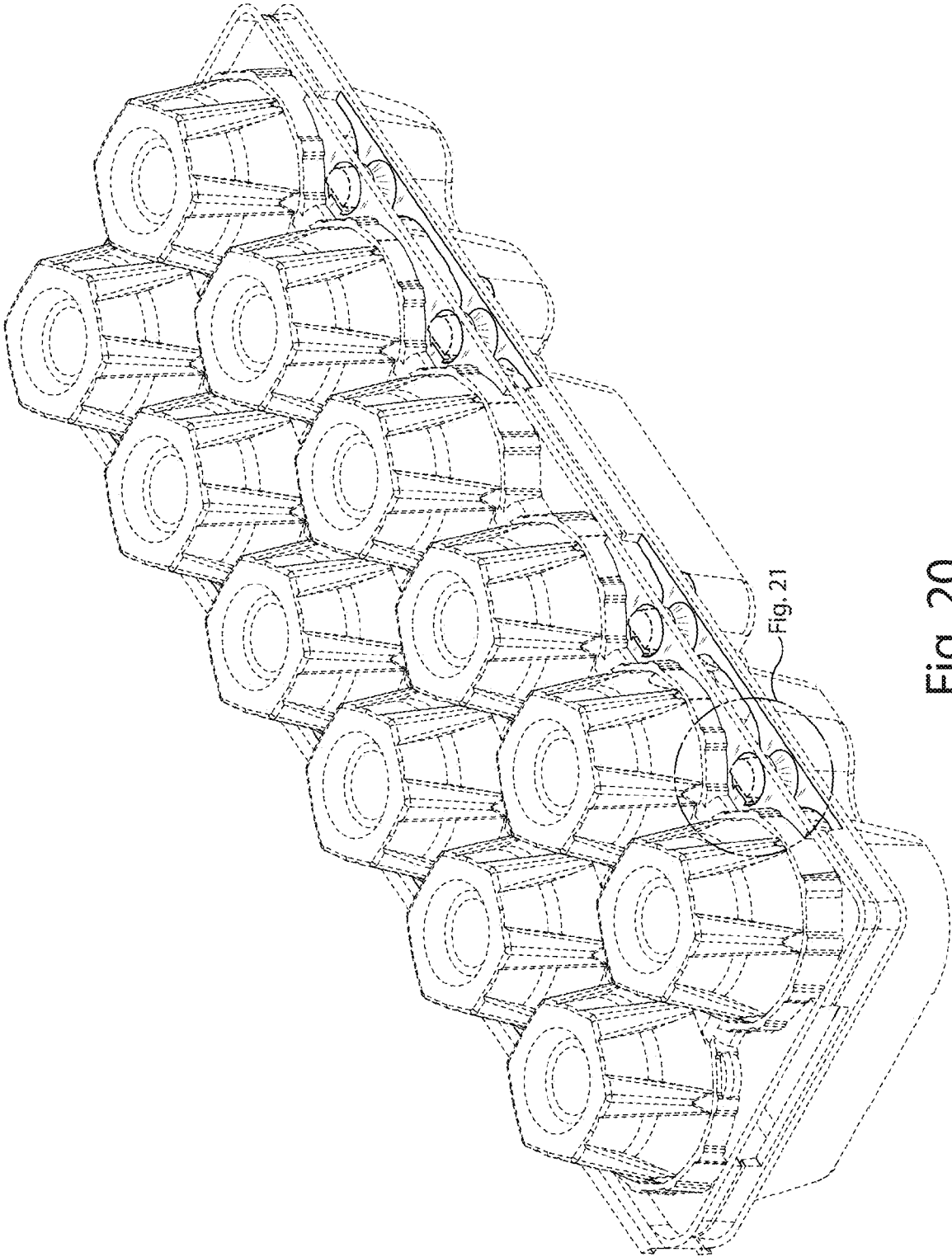

Fig. 20

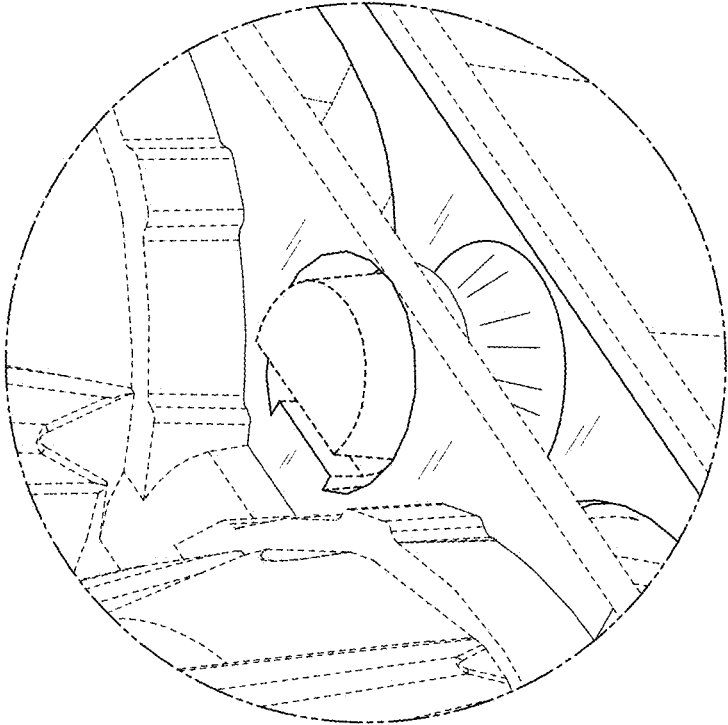

Fig. 21

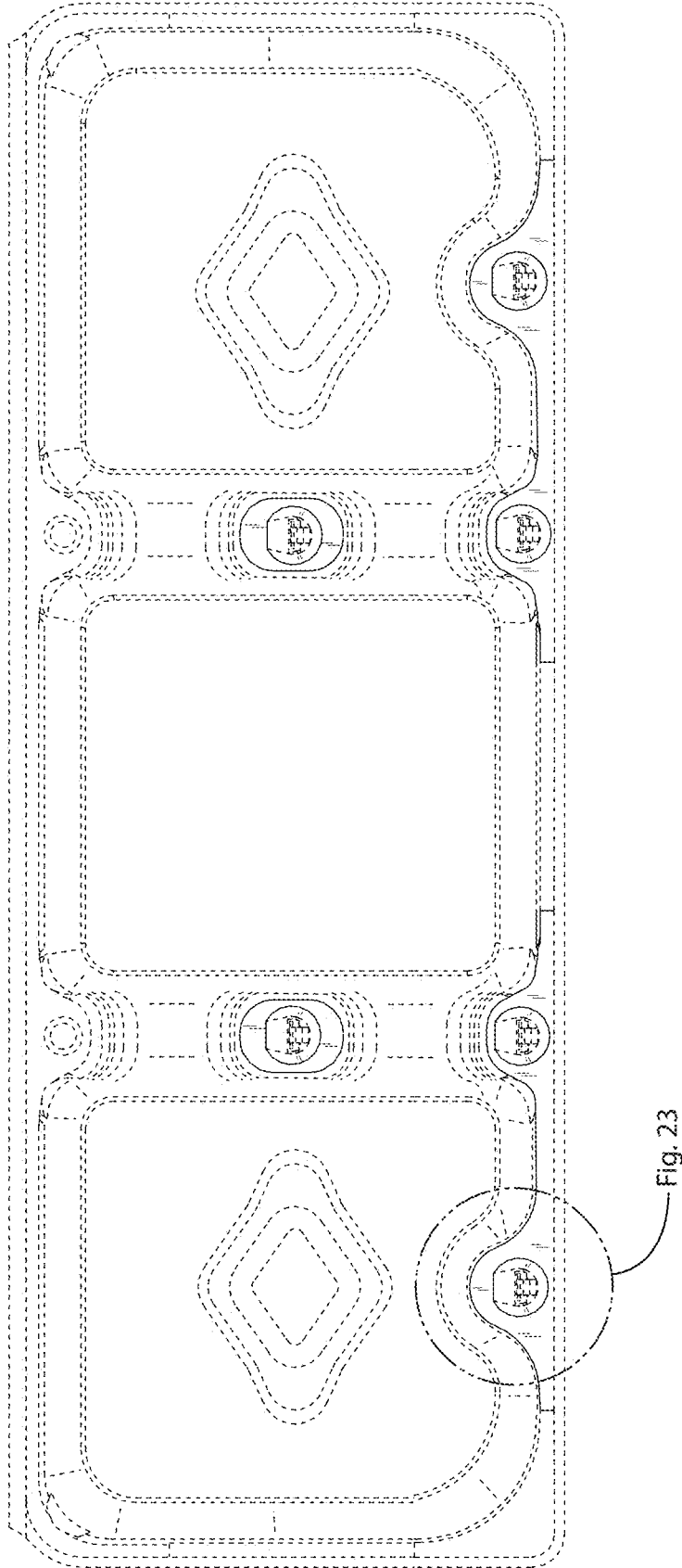

Fig. 22

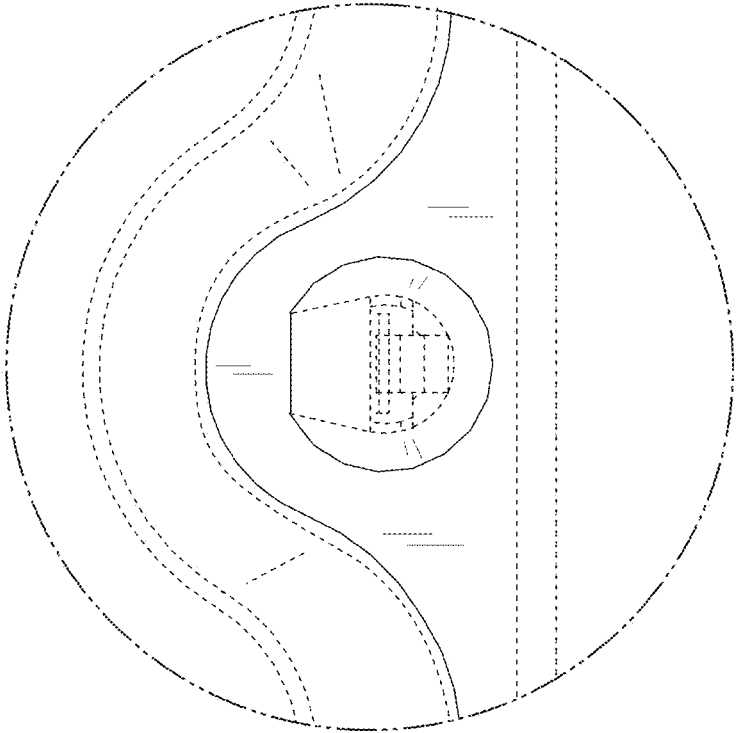

Fig. 23

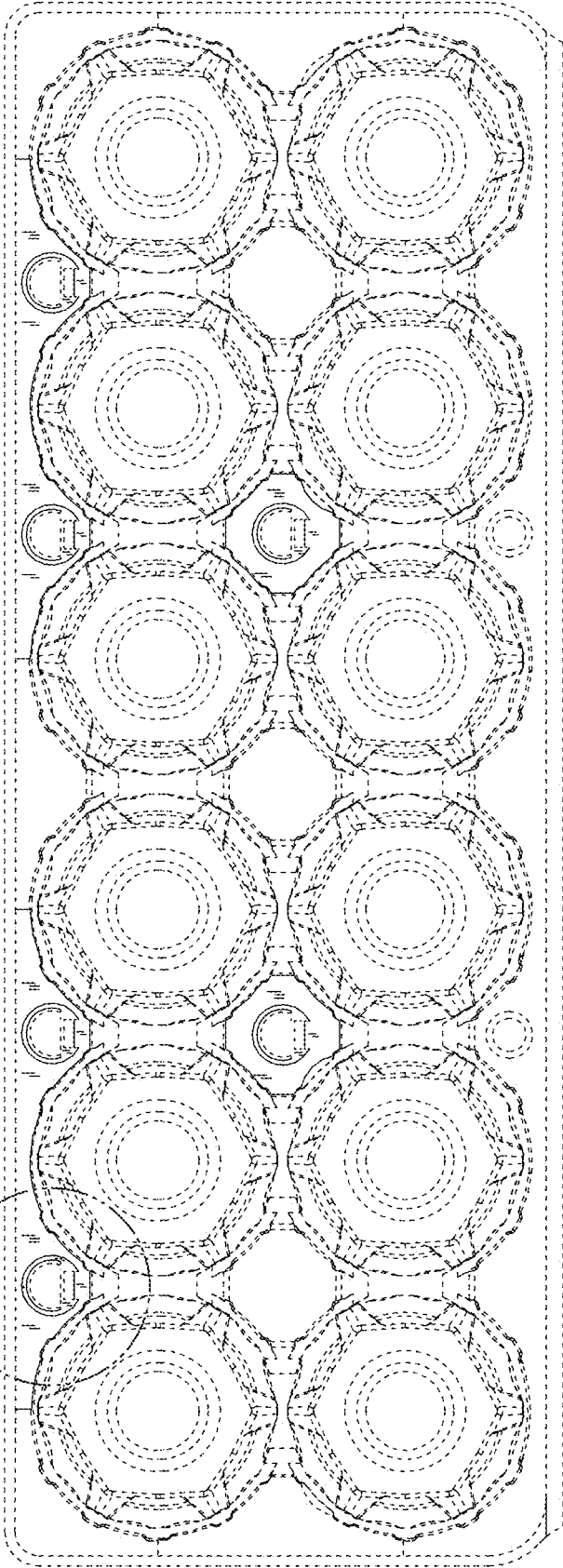

Fig. 25

Fig. 24

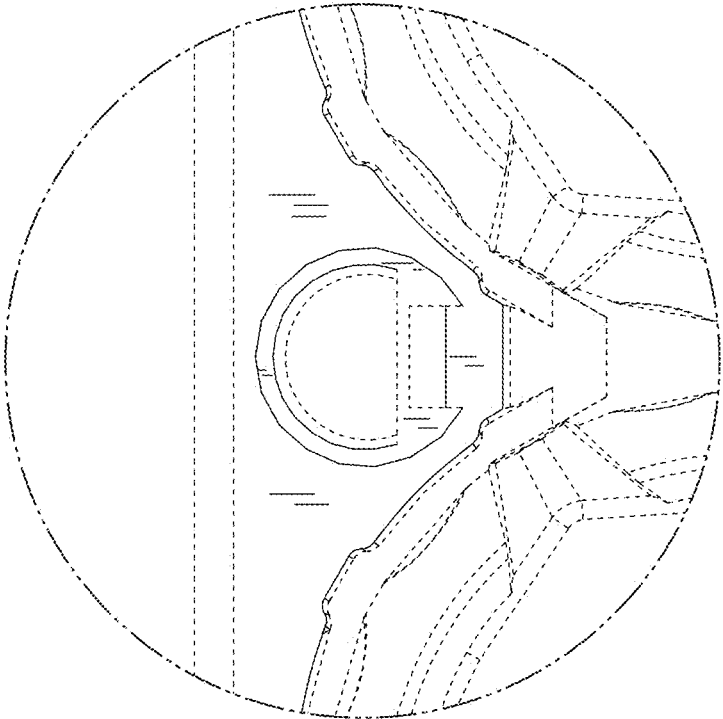

Fig. 25

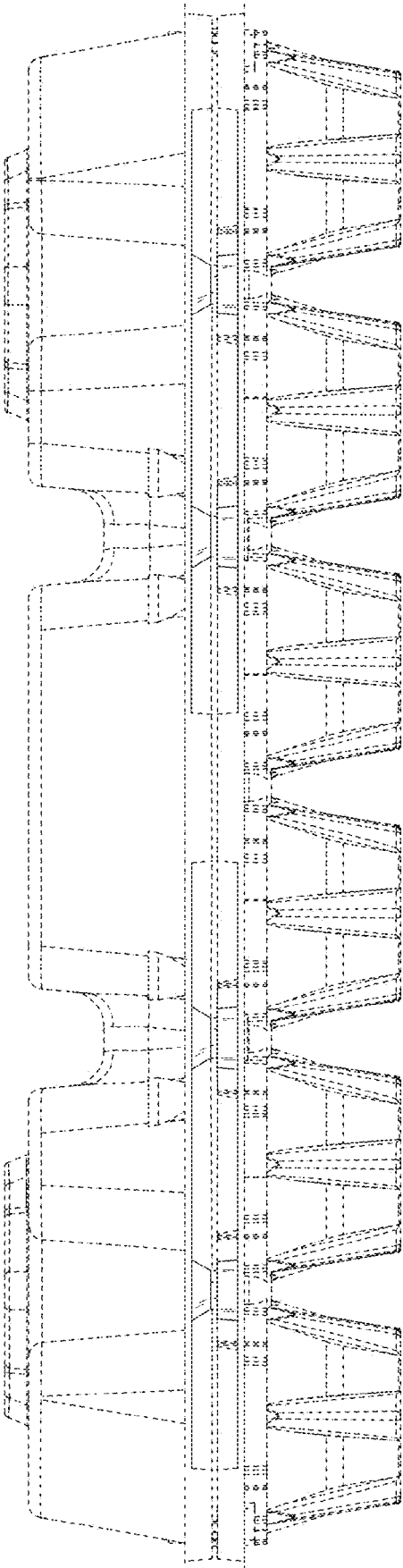

Fig. 26

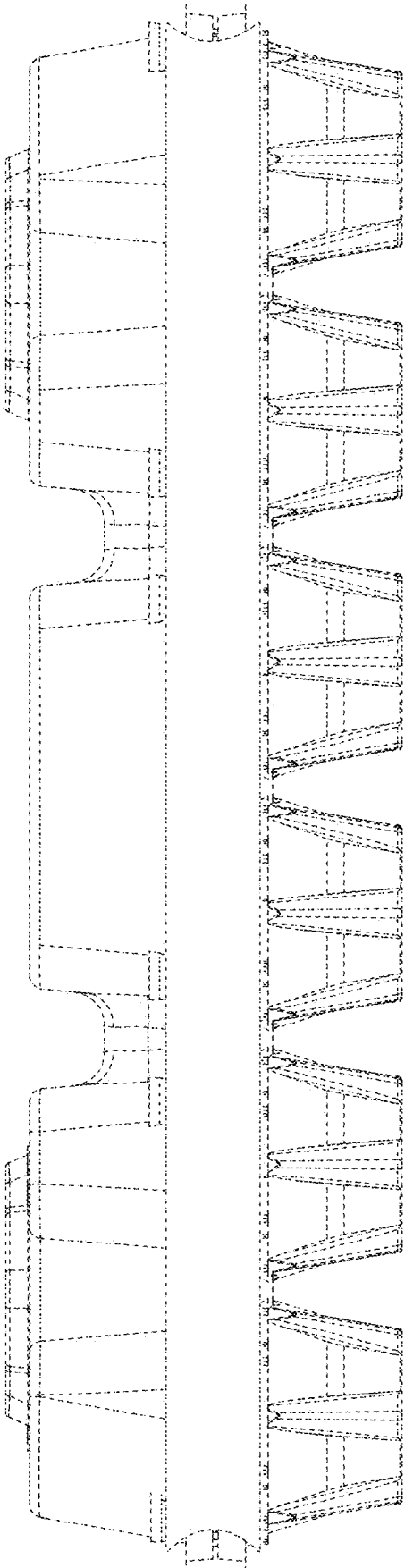

Fig. 27

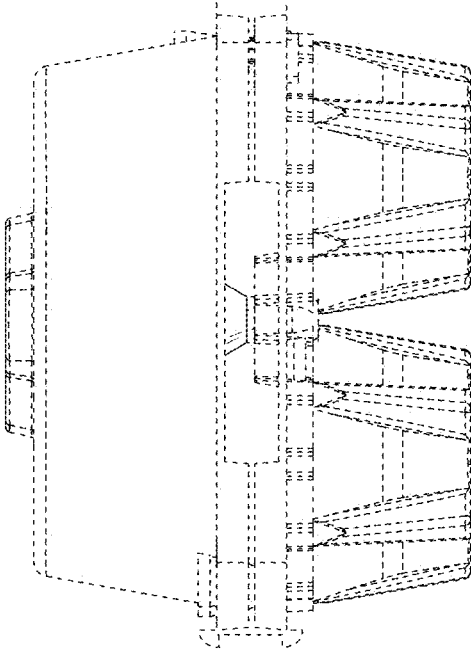

Fig. 28

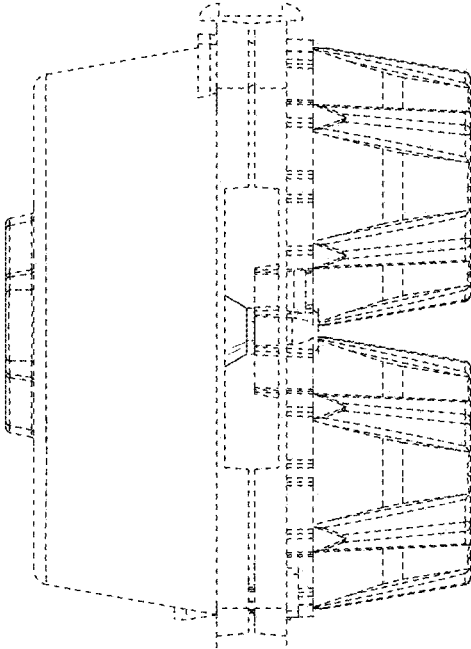

Fig. 29