

(21) Application No 9313747.9

(22) Date of Filing 02.07.1993

(71) Applicant(s)

GEC Avery Limited

(Incorporated in the United Kingdom)

**Smethwick, WARLEY, West Midlands, B66 2LP,
United Kingdom**

(72) Inventor(s)

Charles Richard Jarvis

(74) Agent and/or Address for Service

Roger Keith Tolfree

**GEC Patent Department, Waterhouse Lane,
CHELMSFORD, Essex, CM1 2QX, United Kingdom**

(51) INT CL⁶

G06K 19/077 , B32B 31/20

(52) UK CL (Edition N)

B6A AC91 AK

(56) Documents Cited

GB 2225283 A

(58) Field of Search

UK CL (Edition L) B6A AK

INT CL⁵ G06K

ONLINE DATABASES : WPI

(54) **A method of manufacturing a laminated integrated circuit or smart card.**

(57) A method of laminating a smart card comprises placing together a printed circuit having components thereon and a sheet of thermoplastics material and forming a laminated card therefrom in a vacuum at an elevated temperature such that the components become embedded in the sheet, the vacuum preventing pockets of air being trapped in the process. The pressing process includes a number of stages to prevent the components on the circuit being crushed. The process includes an intermediate pulsed press pressure stage whilst the thermoplastics material is soft, followed by an increased pressure and temperature stage. Cooling is effected under press pressure. The layers 41 to be assembled are placed between pressing plates 42 in pressing case 43a, b connected to vacuum by line 45.

FIG. 12

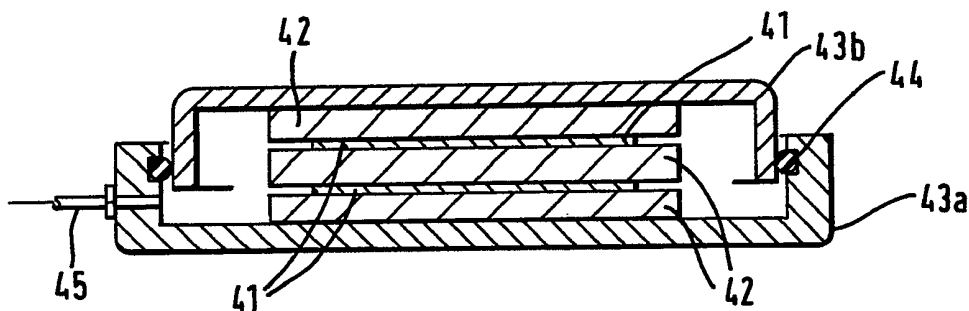



FIG. 1

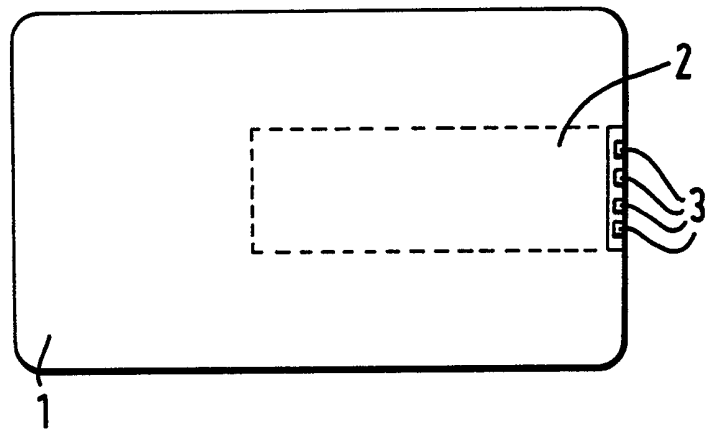

FIG. 2

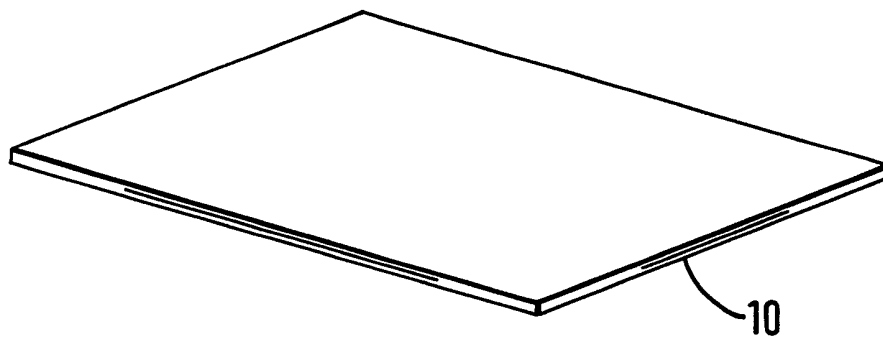

FIG. 3

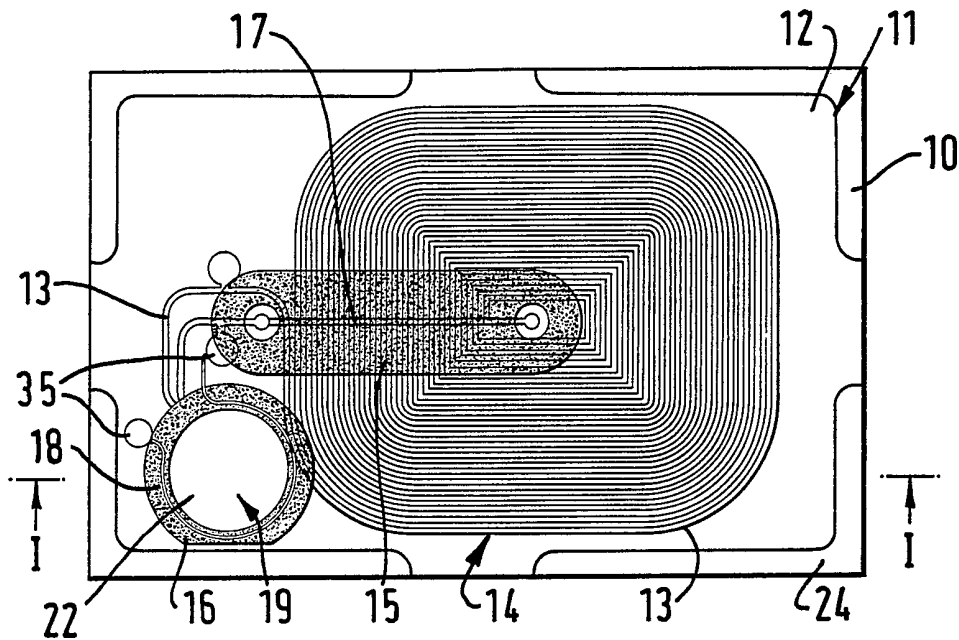
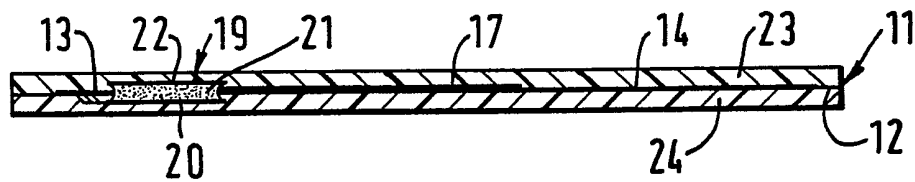

FIG. 4



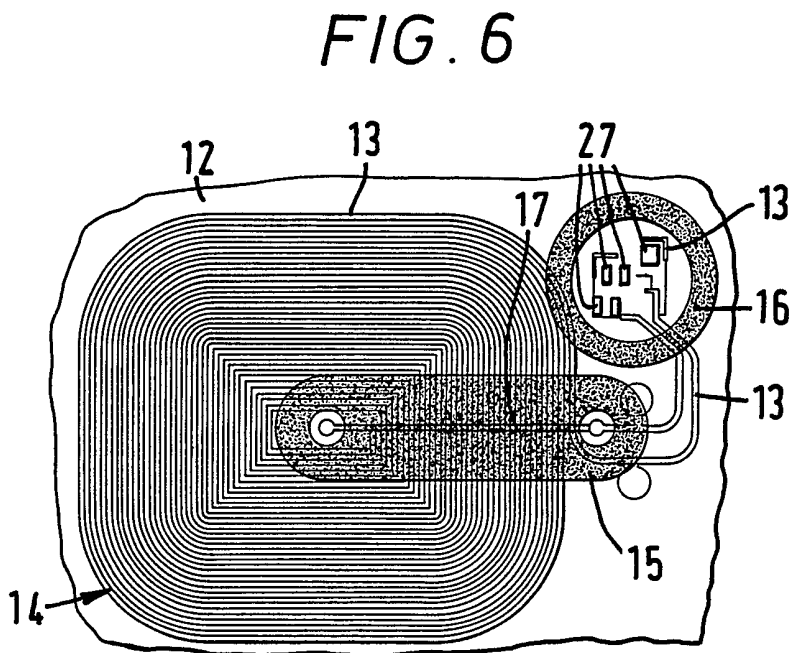
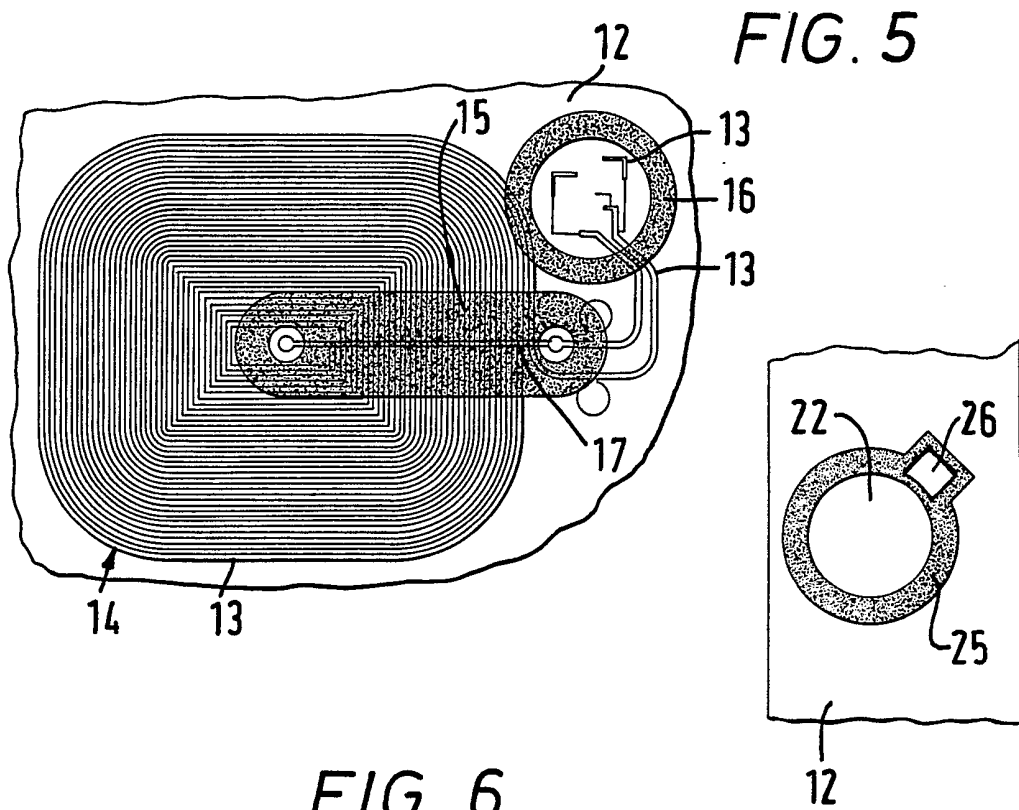

FIG. 7

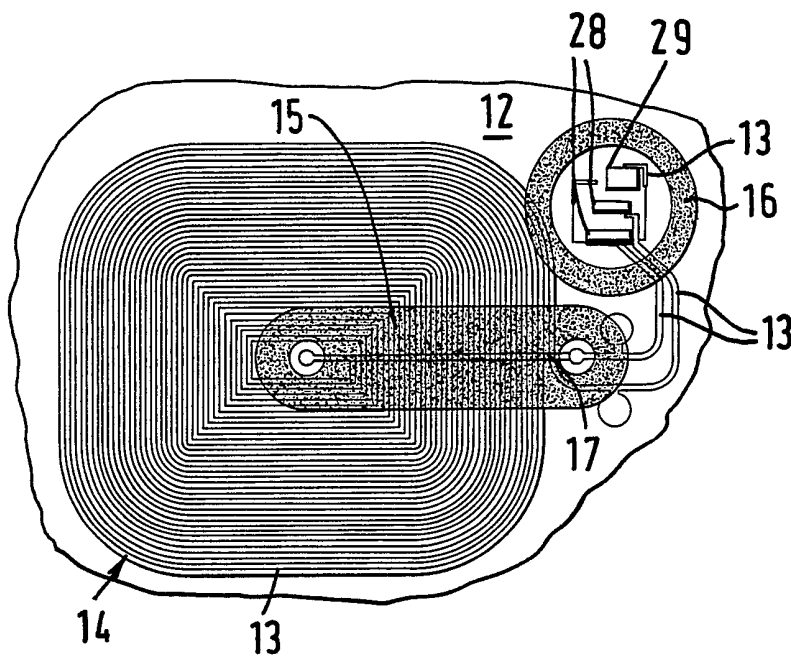

FIG. 8

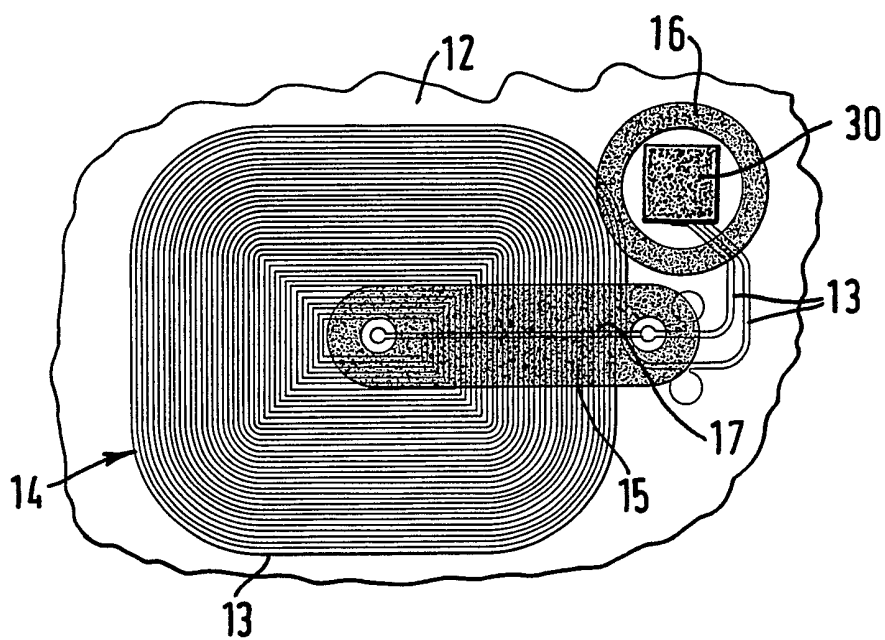

FIG. 9

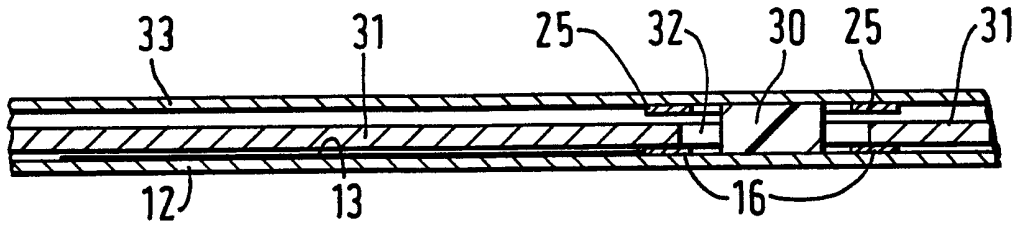

FIG. 10

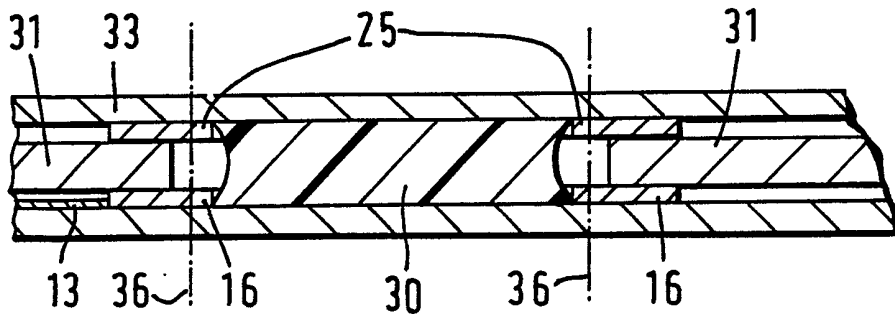

FIG. 11

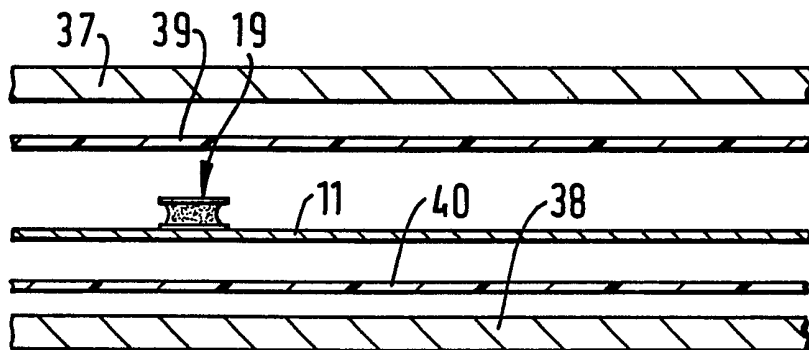
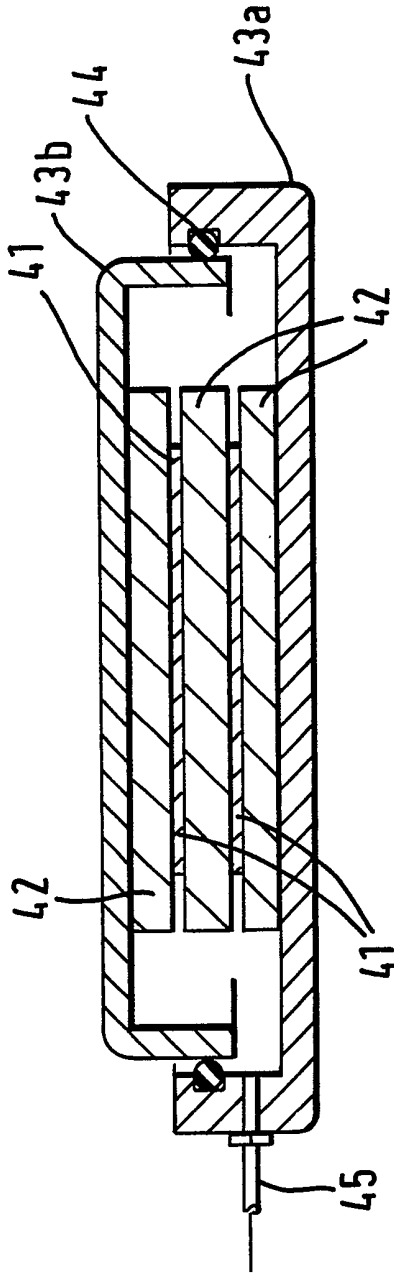

FIG. 12



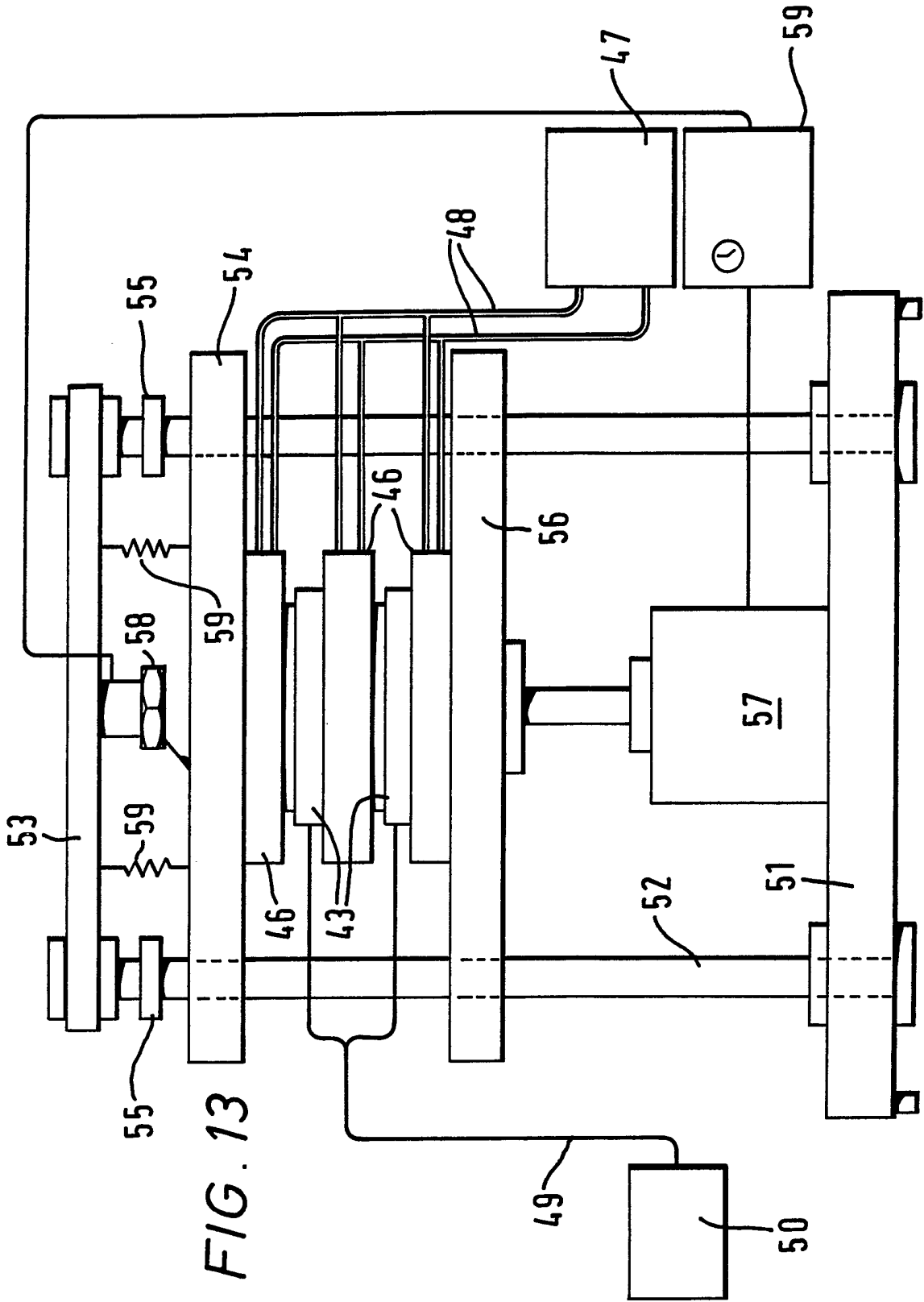

FIG. 13

A METHOD OF MANUFACTURING A LAMINATED CARD

This invention relates to a method of manufacturing a card comprising a printed circuit having a protective layer on at least one side and in particular, but not exclusively, to the manufacture of what are commonly referred to as "smart cards", that is "plastic cards" incorporating electronic components which are carried by individuals and used for such purposes as recording or authorising transactions and/or for authorising entry to buildings. (Note that the term "printed circuit" as used in this specification should be considered to refer to any system of conductive tracks on an insulating substrate, whether such tracks are formed by printing, etching, vapour deposition or any other technique.)

One previously proposed type of "smart card" is illustrated in Figure 1 and comprises a plastic carrier card 1 in which is embedded a printed circuit carrying various components, connections being made by contacts 3 with a suitable communications unit. In such cards the printed circuit 2 which is embedded below the surface of the card is normally relatively small compared to the total surface area of the card. However there is now a requirement for larger printed circuits within cards, particularly if the card communicates with external circuitry by means of an inductive loop embedded within the card, for it is desirable that the loop be as large as possible and therefore almost the whole area of the card is required for the printed circuit. The present invention provides a method of fabricating such a card.

According to the present invention there is provided a method of manufacturing a laminated card one layer of which comprises a printed circuit having components thereon, the method comprising placing the printed circuit and a sheet of protective thermoplastic material together in a press, evacuating and heating the sheet and the printed circuit, and pressing the printed circuit and sheet together such that components on the printed circuit become embedded in the sheet of protective material.

It has been found that by employing the present invention and evacuating the printed circuit/thermoplastic sheet during the lamination process, problems with prototype cards de-laminating, which were produced at normal atmospheric pressure have been overcome. It is believed that these prototype cards de-laminated due to pockets of air being trapped around components on the card as the thermoplastic protective sheet softened, these pockets of air tending to expand with time after being removed from the press which not only affects the structural integrity of the card but also makes the card unsightly.

Preferably the printed circuit is sandwiched between two sheets of protective material and advantageously a number of printed circuits are formed on a common substrate wherein a sheet, or both sheets, of the protective material extend over several circuits, the cards being cut from the resulting laminated structure after pressing. In this way a batch of cards can be produced from a single laminated structure. It is also convenient to produce a number of printed circuits on a common

substrate.

Preferably between the printed circuit and sheet of protective material there is placed an intervening layer and this intervening layer is coated with an adhesive which bonds the protective layer to the printed circuit. It is particularly advantageous if this adhesive is a thermally activated catalyst adhesive, for this will not start to cure until the laminated structure is heated in the press.

Preferably the pressing process comprises: closing a press until the sheet of thermoplastic protective material is in thermal contact with a heating unit; and applying a greater pressure once the thermoplastic material has softened. If the greater pressure were applied immediately before the thermoplastic material had time to soften then components on the printed circuit would effectively be crushed by the hard thermoplastic material. This is advantageously achieved by closing the press until a resiliently mounted reaction platen of the press is displaced, for most of the weight of the reaction platen will be supported by the resilient mounting, wherein once the said greater pressure is applied the reaction platen comes into contact with mechanical stops. Preferably the pressure and temperature are again increased for once the pressure has been increased the first time, better thermal conductivity is gained and the temperature can be raised to a level which actuates the curing process.

It is particularly advantageous if the pressure applied by the press is pulsed as this assists in the bedding in of components on the printed circuit into the

thermoplastic material. It is also advantageous to cool the resultant laminated structure whilst still under pressure.

Preferably the sheet of protective material and printed circuit are placed together between a base portion and cover portion of a pressing case which portions are arranged to slide relative to each other on the action of the press, the pressing case comprising a seal between the portions and an outlet by which the pressing case can be evacuated, this enabling the elements of the card to be laminated to be assembled in the case which can be evacuated, and preferably a plurality of sets of printed circuits and protective sheets are contained within a single case each set being separated by a rigid plate ensuring each set ends up with the same surface profile as the rigid plate which would normally be planar. Preferably a number of pressing cases are assembled between the platens of a press with a substantially incompressible heating unit placed between each adjacent pair of pressing cases in the press.

One embodiment of the invention will now be described, by way of example only, with reference to Figures 2 to 13 of the accompanying drawings in which like numerals have been used to indicate like parts, and of which:

Figure 1 schematically illustrates a previously proposed arrangement (not in accordance with the invention) of electrical components in a plastic card;

Figure 2 is a perspective view of a plastic card produced by a method in

accordance with the present invention;

Figure 3 is a plan view of the card of Figure 2 having its top sheet 4 removed to reveal the printed circuit;

Figure 4 is a cross-section through the card along the line I - I of Figure 3; and

Figures 5 to 13 illustrate various stages in the production of the plastic card depicted in Figures 2 to 4.

Referring first to Figure 2 there is shown a perspective view of the final card which has the same external dimensions as a standard "plastic card". The card contains an integrated circuit. On Figure 2 it is possible to see edge portions of a substrate of the integrated circuit, exposed at a central part of each edge of the card. The integrated circuit communicates with interrogation units via an inductive link located at appropriate locations. The integrated circuit would normally contain a memory device and could be used for any number of purposes, for example recording banking transactions or recording zones of buildings etc to which entry has been gained by use of the card as an identity card.

Referring to Figure 3 there is illustrated a plan view through a section of the card 10 of Figure 2 in the plane of the card. From this and the cross-section along line I - I illustrated in Figure 4 it can be seen that a printed circuit 11 comprises

epoxy/glass substrate 12 and conductive tracks 13, a substantial portion of which form conductive loop 14. Darkly shaded regions 15 and 16 comprise of a thermoset dielectric material. The purpose of the region 15 is to insulate a silver conductor 17 from the inductive coil 14. The purpose of dielectric layer 16 will be explained later.

An integrated circuit and capacitive components, not shown in Figures 3 or 4, are contained within a capsule-like element 19 which is separated by cut 18 from the rest of the substrate 12. The region 20 of the substrate 12 is lowered below the plane of the printed circuit 11, the integrated circuit and capacitive components being located in potting compound 21 sandwiched between the portion of the substrate 20 and a capping portion 22 of the same material as the substrate 12.

The printed circuit 11 and element 19 are sandwiched between two outer sheets 23 and 24 of PVC thermoplastics material and two intervening layers (not shown in Figures 3 or 4), of polyester which is coated on both sides with a thermally activated catalyst adhesive by which the laminated structure is adhered. This polyester acts as a reinforcing layer preventing element 19 "breaking out" of the PVC layers 23 and 24.

The fabrication process of the card illustrated in Figures 2, 3 and 4 begins with a substrate sheet 12 of copper-clad epoxy/glass which is etched to form a large number of identical printed circuits 13, each as illustrated in Figure 5. On top of each printed circuit is printed a thermoset dielectric material indicated by the shaded regions

15, 16 which is cured in place. The function of circular part 15 is explained below. The linear part 16 serves as an insulator to separate printed conductive link 17 between inner and outer ends of a coil 14 defined by part of the printed circuit 13. Separated from a main part of the substrate by lines of weakness not shown are a number of strips (not shown), each carrying printed patterns 25 (only one of which is illustrated), with apertures 26 therein, which ultimately become the top reinforcing caps of the elements 19.

The substrate carrying the etched patterns is placed on a bed of a screen printing machine (not shown) and a screen placed over it. A squeegee is then used to print a low ionic epoxy encapsulant/adhesive material onto positions 27 as shown in Figure 6. This is a mixture of a resin and a catalyst which sets hard when cured. Suitable materials are, for example, available from Ablestick, Encaremix, or Dexter Hisol. The substrate is then placed in a "pick-and-place" machine which places components comprising of capacitors 28 and silicon chips 29, shown in Figure 7, onto the epoxy which acts as an adhesive to hold them in place. The silicon chips 29 at this stage are "naked", that is to say they are not encapsulated. A notable feature of this process is that the epoxy is applied to areas where there is no copper layer, this being unnecessary because of the adhesive attachment of the components. A saving of 35 microns in thickness is thus achieved as compared with arrangements where components are soldered on top of a copper track. It will be appreciated that this reduction of thickness may be of crucial importance in situations where there may typically be a requirement for the entire assembly not to exceed 760 microns. An

advantage of using epoxy adhesive is that if suitably selected it remains in its adhesive state for a sufficient time period which exceeds the maximum period during which the screen printing machine is not being operated. This avoids the need to clean down the equipment.

The sheet substrate carrying the etched patterns and respective components positioned on it, is then baked until the epoxy has gelled, i.e. set but not hardened. This takes place under a flow of nitrogen to prevent oxidation of the copper. The sheet is then placed on the work-holder of a wire bonding machine where it is held in position by a vacuum. Suitable machines for this purpose are commercially available. Wire connections are then made between contacts on the individual components to appropriate parts of the printed copper circuitry. This is done by an ultrasonically assisted diffusion welding process. The sheet is then placed back in the screen printer with a different stencil in place. This stencil is much thicker, its thickness being selected so that the same epoxy encapsulant/adhesive now to be deposited over the components is sufficient to cover them completely. Notably, this material is the same as that which was used for the adhesive. It does not have to be the same but it preferably has similar physical characteristics. After the removal of the stencil, the sheet is as shown in Figure 8, the components being encapsulated by the encapsulant 30.

Figure 9 shows in cross-section the next stage of the process where a copper spacer 31 having a plurality of apertures 32 (corresponding to each of the regions on

the sheet having encapsulant 30 deposited thereon) is located on the sheet, 12. Previously placed on the copper sheet is each of the now separated strips 33, previously referred to, to form regions defined by printed patterns 25, from which regions reinforcing caps 22 will be formed. The spacer 31, with strips 33 located on it by means of pins (not shown for clarity), has been placed on top of the substrate. The whole arrangement is then pressed such that the patterns 25 are pressed into contact with the spacer 31 which is thus pressed closely down onto the circular part 16 of the dielectric material. It also presses the portions of the strip 33 defined by the patterns 25 onto the, still soft, epoxy encapsulant/adhesive thereby pulling the entire assembly down to the desired height. During this process the encapsulant spreads out as shown in detail in Figure 10, but not as far as the edges of the spacer sheet. It is prevented from doing so by its meniscus acting against the inner edges of the copper pattern 25 and dielectric ring 16, which meniscus thereby defines the radius of the encapsulant.

The whole assembly is now placed in an oven and cured at a temperature of 150°C. This fully gels the encapsulant/adhesive both under the components and the encapsulant portion. The assembly is now placed on a rule die which forms cuts 34 which can be seen in Figure 3. These cuts are "horseshoe-shaped" and configured so that their free ends correspond with the slots 26 (see Figure 5) in the strip 33. Note at this stage that the ends of each cut are located on the copper pads 35 of Figure 3. The cutter presses through the structure as illustrated by dotted lines 36 in Figure 10, leaving the element 19 on a limb of the substrate 11, as is best seen from

Figure 3, and leaving the spacer 31 and remaining portions of the strips 33 free to be removed.

It will be noted from Figure 3 that the electrical connections to the element run parallel to an edge of the card, in which direction the card is most resistant to bending, as opposed to across the hinge line which runs across the corner of the card where it is most susceptible to bending.

Using another rule die, cruciform shapes are cut out of the assembly to give each printed circuit the shape illustrated in Figure 3. This removes the epoxy/glass substrate from those areas which are to become the corners of the finished cards. It is notably these corner parts which are most subject to the type of manipulation which encourages de-lamination.

The printed circuit 11 with reinforced element 19 is now placed, as shown in Figure 12, between two outer sheets 37 and 38 of thermo plastics material in the pvc family with the inter-position of polyester layers coated on both sides with a thermally activated catalyst adhesive 21. As shown in Figure 12 sets of assembled layers 42 are placed between pressing plate 42 which are placed in pressing case 43. This comprises a lid portion which seals against sealing insert 44 but is free to be compressed into the base portion of the case 43. The case has an outlet pipe 45. Note that in Figure 12 although only two sets of layers are in each case, a case could contain many such sets.

Referring to Figure 13 there is illustrated a press in which two cases 43 are positioned between substantially incompressible heating elements connected by pipes 48 to heater 47. The cases are connected by pipe 49 to vacuum pump 50. Again although only two cases have been shown in the press it will be realised that many such cases could be pressed together.

The press of Figure 13 comprises a base plate 51 from which three support columns 52 extend to a fixed top portion 53. From this top portion 53 is hung by means of springs 59 a top platen 54 such that it rests slightly below stops 55 on support columns 51 on which it slides. A bottom platen 56 which can also slide on columns 52 and which supports the heater units and pressing cases is itself supported by a hydraulic ram 57. Once the pressing cases are positioned in the press the ram is activated and raises the bottom platen 56 until the top platen starts to rise which is detected by micro switch 58. The micro switch then sends a signal to a control means 59 which stops the ram 57. The pressing cases 43 are then evacuated by pump 50 and the heater 47 is energised such that it heats the heating units 46.

It will be realised that at this stage there is very little pressure applied to the cases as top platen 54 is still supported by springs 59. This is important otherwise the components sandwiched between the still hard pvc sheets 37 and 38 would be crushed. However there is enough pressure to establish thermal contact between thermal units 46 and all elements in cases 43 including the pvc sheets 37 and 38 which start to soften with the applied heat. When a temperature of approximately

110°C is reached the pvc is fairly soft and an intermediate pressure is applied by ram 57 and the sandwich starts to collapse. During this process the pressure of the ram is pulsed causing progressive compression. During this stage the capsules 19 imbed themselves in the sheets of thermo-plastic material in such a way as to tend to centralise themselves between opposite faces leaving the plane of the substrate sheet 1 on the central axis as shown in Figure 4. The vacuum ensuring no air is trapped. The work piece now heats up more rapidly because of improved thermal contact and the temperature is raised to about 155°C. Full lamination pressure is now applied, activating the catalyst in the adhesive. Whilst still under pressure the assembly is cooled and brought down to room temperature. The press now opens and the assembly is removed to a cutting machine where the individual cards as illustrated in Figures 2 and 3 are cut out.

CLAIMS

1. A method of manufacturing a laminated card one layer of which comprises a printed circuit having components thereon, the method comprising placing the printed circuit and a sheet of protective thermoplastic material together in a press, evacuating and heating the sheet and the printed circuit, and pressing the printed circuit and sheet together such that components on the printed circuit become embedded in the sheet of protective material.
2. A method as claimed in claim 1 wherein the printed circuit is sandwiched between two sheets of protective material.
3. A method as claimed in claim 1 or 2 wherein a number of printed circuits are formed on a common substrate and wherein a sheet of protective material extends over several circuits, the cards being cut from the resultant laminated structure after pressing.
4. A method as claimed in any preceding claim wherein between the printed circuit and sheet of protective material there is placed an intervening layer.
5. A method as claimed in claim 4 wherein the intervening layer is coated with an adhesive which bonds the protective layer to the printed circuit.

6. A method as claimed in claim 5 wherein the adhesive on the intervening layer is a thermally activated catalyst adhesive.

7. A method as claimed in any preceding claim wherein the pressing process comprises: closing a press until the sheet of thermoplastic protective material is in thermal contact with a heating unit; and applying a greater pressure once the thermoplastic material has softened.

8. A method as claimed in claim 7 wherein the press closes until a resiliently mounted reaction platen of the press is displaced, and wherein once the thermoplastic material has softened the said greater pressure forces the reaction platen into contact with mechanical stops.

9. A method as claimed in claim 7 or 8 wherein after a period at the greater pressure the pressure and temperature are further increased.

10. A method as claimed in claim 9 wherein the further increase in temperature causes the adhesive to cure.

11. A method as claimed in any preceding claim wherein the pressure applied by the press is pulsed.

12. A method as claimed in any preceding claim wherein the resultant laminated

structure is cooled whilst still under pressure.

13. A method as claimed in any preceding claim wherein the sheet of protective material and printed circuit are placed together between a base portion and cover portion of a pressing case which are arranged to slide relative to each other on the action of the press, the pressing case comprising an airtight seal between the portions and an outlet by which the pressing case can be evacuated.

14. A method as claimed in claim 13 wherein a plurality of sets of printed circuits and protective sheets are contained within a single pressing case, each set being separated by a rigid plate.

15. A method as claimed in claim 13 or 14 wherein a number of pressing cases are assembled between the platens of a press.

16. A method as claimed in claim 15 wherein a substantially incompressible heating unit is placed between each adjacent pair of pressing cases in the press.

17. A method substantially as hereinbefore described with reference to Figures 12 and 13 of the accompanying drawings.

18. A press substantially as hereinbefore described with reference to, and as illustrated in, Figure 13 of the accompanying drawings.

Patents Act 1977
Examiner's report to the Comptroller under
Section 17 (The Search Report)

Application number

GB 9313747.9

16

Relevant Technical fields

(i) UK CI (Edition L) B6A (AK)

(ii) Int CI (Edition 5) G06K

Search Examiner

G J W RUSSELL

Databases (see over)

(i) UK Patent Office

(ii) ONLINE DATABASES: WPI

Date of Search

5 OCTOBER 1993

Documents considered relevant following a search in respect of claims 1-18

Category (see over)	Identity of document and relevant passages	Relevant to claim(s)
A	GB 2225283 A (DE LA RUE) - see page 11 lines 3-29	



Categories of documents

X: Document indicating lack of novelty or of inventive step.

Y: Document indicating lack of inventive step if combined with one or more other documents of the same category.

A: Document indicating technological background and/or state of the art.

P: Document published on or after the declared priority date but before the filing date of the present application.

E: Patent document published on or after, but with priority date earlier than, the filing date of the present application.

&: Member of the same patent family, corresponding document.

Databases: The UK Patent Office database comprises classified collections of GB, EP, WO and US patent specifications as outlined periodically in the Official Journal (Patents). The on-line databases considered for search are also listed periodically in the Official Journal (Patents).