



- (51) International Patent Classification:
G01S 15/38 (2006.01) *B63C 11/38* (2006.01)
- (21) International Application Number:
PCT/US2018/039189
- (22) International Filing Date:
24 June 2018 (24.06.2018)
- (25) Filing Language: English
- (26) Publication Language: English
- (30) Priority Data:
62/528,354 03 July 2017 (03.07.2017) US
- (71) Applicant: **R2SONIC, LLC** [US/US]; 5307 Industrial Oaks Boulevard # 120, Austin, TX 78735 (US).
- (72) Inventors: **STEENSTRUP, Jens**; 5307 Industrial Oaks Boulevard # 120, Austin, TX 78735 (US). **TIEMANN, Christopher**; 5307 Industrial Oaks Boulevard # 120, Austin, TX 78735 (US). **BILODEAU, Peter**; 5307 Industrial Oaks Boulevard # 120, Austin, TX 78735 (US). **CHUN, Mark**; 5307 Industrial Oaks Boulevard # 120, Austin, TX 78735 (US). **HOBART, Kirk**; R2sonic, Llc, 5307 Industrial Oaks Boulevard # 120, Austin, TX 78735 (US).

- (74) Agent: **CHANCELLOR, Paul**; Ocean Law, 3463 Red Bluff Court, Simi Valley, CA 93063 (US).
- (81) Designated States (*unless otherwise indicated, for every kind of national protection available*): AE, AG, AL, AM, AO, AT, AU, AZ, BA, BB, BG, BH, BN, BR, BW, BY, BZ, CA, CH, CL, CN, CO, CR, CU, CZ, DE, DJ, DK, DM, DO, DZ, EC, EE, EG, ES, FI, GB, GD, GE, GH, GM, GT, HN, HR, HU, ID, IL, IN, IR, IS, JO, JP, KE, KG, KH, KN, KP, KR, KW, KZ, LA, LC, LK, LR, LS, LU, LY, MA, MD, ME, MG, MK, MN, MW, MX, MY, MZ, NA, NG, NI, NO, NZ, OM, PA, PE, PG, PH, PL, PT, QA, RO, RS, RU, RW, SA, SC, SD, SE, SG, SK, SL, SM, ST, SV, SY, TH, TJ, TM, TN, TR, TT, TZ, UA, UG, US, UZ, VC, VN, ZA, ZM, ZW.
- (84) Designated States (*unless otherwise indicated, for every kind of regional protection available*): ARIPO (BW, GH, GM, KE, LR, LS, MW, MZ, NA, RW, SD, SL, ST, SZ, TZ, UG, ZM, ZW), Eurasian (AM, AZ, BY, KG, KZ, RU, TJ, TM), European (AL, AT, BE, BG, CH, CY, CZ, DE, DK, EE, ES, FI, FR, GB, GR, HR, HU, IE, IS, IT, LT, LU, LV, MC, MK, MT, NL, NO, PL, PT, RO, RS, SE, SI, SK, SM, TR), OAPI (BF, BJ, CF, CG, CI, CM, GA, GN, GQ, GW, KM, ML, MR, NE, SN, TD, TG).

(54) Title: MULTI-PERSPECTIVE ENSONIFICATION SYSTEM AND METHOD

FIG. 3A

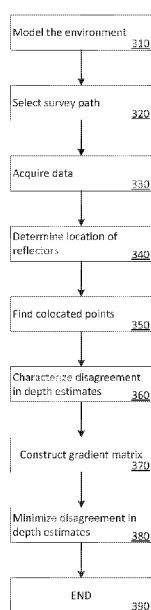

300A

(57) Abstract: A survey system and method to improve one or more of survey quality, efficiency, and utility for example by utilizing a vessel mounted MBES and a selected survey plan to check sound speed(s) via eliciting echoes from reflectors in collocated groups of reflectors using multi -perspective ensonification.

WO 2019/010022 A1

Declarations under Rule 4.17:

- *as to applicant's entitlement to apply for and be granted a patent (Rule 4.17(ii))*
- *as to the applicant's entitlement to claim the priority of the earlier application (Rule 4.17(iii))*

Published:

- *with international search report (Art. 21(3))*
- *before the expiration of the time limit for amending the claims and to be republished in the event of receipt of amendments (Rule 48.2(h))*

**TITLE: MULTI-PERSPECTIVE ENSONIFICATION
SYSTEM AND METHOD**

**PRIORITY CLAIM, BENEFIT CLAIM AND INCORPORATION BY
REFERENCE**

[001] This application claims the benefit of U.S. Provisional Pat. Application No. 62/528,354 filed July 3, 2017. This application incorporates by reference, in their entireties and for all purposes, the disclosures of U.S. Pat. Nos. 3,144,631 concerning Mills Cross sonar, 8,305,841 concerning sonar used for mapping seafloor topography, 7,092,440 concerning spread spectrum communications techniques, 5,483,499 concerning Doppler frequency estimation, and 9,244,168 concerning frequency burst sonar.

BACKGROUND OF THE INVENTION

Field of the Invention

[002] The present invention relates to underwater acoustical systems, methods of using underwater acoustical systems, and methods for processing and using the data they produce. In particular, the invention relates to survey systems including multibeam sonar systems capable of obtaining multi-perspective ensonification data.

Discussion of the Related Art

[003] A month after the Titanic struck an iceberg in 1912, English meteorologist Lewis Richardson filed a patent at the British Patent Office for an underwater ranging device. Modern day successors to Richardson's invention are often referred to as SONAR (sound navigation and ranging) devices. Among these devices are ones using transducer arrays to project sound or pressure waves through a liquid medium and transducer arrays to receive corresponding echoes from features that scatter and/or reflect

impinging waves.

[004] Information about these features and their environment can be derived from the echoes. For example, bathymetric surveys provide information about the depth of scattering centers, water column surveys provide information about scattering centers in the water column, and seafloor characterization surveys provide information about scattering centers at the seafloor surface and below the seafloor surface. The diversity and quality of the information returned in echoes may be determined in part by the characteristics of the signal used to excite the projector transducers.

[005] The cost of obtaining this information is strongly influenced by the timeframe during which manpower and equipment is required to acquire the information.

[006] Although some progress towards improving data quality and diversity while reducing the time required to perform an underwater survey has been made, particularly through the use of multibeam echo sounders, long standing technological challenges and risks associated with building and testing costly new survey equipment present significant obstacles to further similar improvements.

SUMMARY OF THE INVENTION

[007] The present invention provides a multi-perspective ensonification system and method. In an embodiment, a multi-perspective ensonification method comprising the steps of: installing a multibeam echo sounder system ("MBES") on a water going vehicle such that one or more transducers in a single MBES projector array and plural transducers in a single MBES hydrophone array are in a Mills Cross arrangement; modeling a waterbody with a plurality of "j" superposed layers ($l_1 \dots l_j$) having respective layer thicknesses ($t_1 \dots t_j$), each of the j layers having a layer entry sound speed and a layer exit sound speed such that a set of

(j+1) sound speed values ($c_1, c_2 \dots c_{j+1}$) characterize the sound speed profile through the layers; designing a vehicle route and traversing the route such that during MBES operation along the route i) plural primary areas are ensonified, ii) plural secondary areas are ensonified, iii) each primary area is overlapped by a respective secondary area, and iv) for each overlap a first echo originating therein traverses a first path to the MBES and a second echo originating therein traverses a second path to the MBES at a location different from the first; via a travel time corresponding to each echo, modeling the propagation of sound through the waterbody to locate in three dimensions a reflector that returned the echo; one of the dimensions indicating a waterbody depth and the other two dimensions indicating coordinates in a reflector plane parallel to the waterbody free surface; selecting a colocation metric and using the metric to identify groups of reflectors that are colocated in the reflector plane; for each group of colocated reflectors, quantifying disagreements in the waterbody depths corresponding to the reflectors in the group; and, determining a set of adjusted sound speed values that tends to simultaneously reduce the disagreement within each group of depth estimates.

BRIEF DESCRIPTION OF THE DRAWINGS

[008] The present invention is described with reference to the accompanying figures. These figures, incorporated herein and forming part of the specification, illustrate embodiments of the invention and, together with the description, further serve to explain its principles enabling a person skilled in the relevant art to make and use the invention.

[009] FIG. 1A shows a survey system including a multibeam echo sounder system ("MBES") of the present invention.

[010] FIG. 1B shows an embodiment of at least portions of the MBES of FIG. 1A.

[011] FIG. 2A shows a vessel equipped with a Mills Cross type arrangement of transducer arrays for use with the MBES of FIG. 1A.

[012] FIG. 2B shows schematically an MBES fan such as a fan resulting from operation of the echo sounder system of FIG. 1A.

[013] FIGS. 2C-D show an antiparallel track survey plan carried out using the MBES of FIG. 1A.

[014] FIGS. 2E-F show a cross track survey plan carried out using the MBES of FIG. 1A.

[015] FIGS. 2G-H show a same track survey plan carried out using the MBES of FIG. 1A.

[016] FIGS. 2I-J show an exemplary waterbody model for use with the surveys of FIGS. 2B-H.

[017] FIGS. 3A-G show a process using the MBES of FIG. 1A for testing sound speeds used in depth estimates.

[018] FIG. 4 shows a method using the MBES of FIG. 1A for synthesizing a sound speed profile using the MBES of FIG. 1A.

DETAILED DESCRIPTION OF THE PREFERRED EMBODIMENTS

[019] The disclosure provided in the following pages describes examples of some embodiments of the invention. The designs, figures, and description are non-limiting examples of the embodiments they disclose. For example, other embodiments of the disclosed device and/or method may or may not include the features described herein. Moreover, described features, advantages or benefits may apply to only certain embodiments of the invention and should not be used to limit the disclosed invention.

[020] As used herein, the term “coupled” includes direct and indirect connections. Moreover, where first and second devices are coupled, intervening devices including active devices may be located therebetween.

[021] **Survey System**

[022] FIG. 1A shows a survey system 100A. The survey system includes an echo sounder system such as a multibeam echo sounder system 102 which may be mounted on a surface vehicle or vessel, a remotely operated vehicle, an autonomous underwater vehicle, or the like. As is further described below, echo sounder and/or survey system outputs 114 may be contemporaneous with echo sounder processing of hydrophone data as in some embodiments for bathymetry or non-contemporaneous with processing of hydrophone data as in some embodiments for waterbody bottom classification.

[023] Data acquired by multibeam echo sounder systems 104 includes data from echo sounder listening devices such as hydrophones (e.g., transducers) that receive echoes which are related to the acoustic/pressure waves emanating from the echo sounder projectors but have returned by virtue of an interaction with inhomogeneities of many kinds. The interactions may take the form of reflection or scattering. The inhomogeneities, also known as reflectors and/or scattering centers, represent discontinuities in the physical properties of the medium. Exemplary scattering centers may be found in one or more of i) an ensonified volume of the waterbody such as a water column, ii) upon the ensonified surface of the bottom, or iii) within the ensonified volume of the sub-bottom.

[024] Scattering centers of a biological nature may be present in the water column, as they are a part of the marine life. Scattering centers of a nonbiological nature may be present in the water column in the form of bubbles, dust and sand particles, thermal microstructure, and turbulence of natural or human origin, such as ships' wakes. Scattering centers on the surface of the bottom may be due to the mechanical roughness of the bottom, such as ripples, or be due to the inherent size, shape and physical arrangement of the bottom constituents, such as mud, sand, shell fragments, cobbles and boulders, or due to both factors. Scattering centers in the sub-bottom may be due to bioturbation of the sediments, layering of

different sediment materials within the bottom, or buried manmade structures such as pipelines.

[025] Data processing within the echo sounder system may include contemporaneous processing of hydrophone data 106, for example to obtain bathymetric and/or backscatter data. Data processing may also include non-contemporaneous processing of multibeam echo sounder system data 108, for example to characterize the environment including bottom conditions or the water column.

[026] Data processing may include utilization of complementary or other data. For example, contemporaneous processing of hydrophone data 106 may utilize contemporaneous 110 and/or non-contemporaneous 112 data such as contemporaneously collected global positioning system (“GPS”) data, sound speed measurements, attitude, and navigational information. For example, non-contemporaneous processing of echo sounder system data may utilize contemporaneous 110 and/or non-contemporaneous 112 data such as non-contemporaneously collected waterbody bottom composition data and tidal records.

[027] FIG. 1B shows portions of an exemplary multibeam echo sounder system (“MBES”) 100B. The echo sounder system includes a transducer section 120 and an acoustic transceiver 122. The echo sounder system may include a transceiver interface such as an interface module 124 and/or a workstation computer 126 for one or more of data processing, data storage, and interfacing man and machine. Exemplary transducers, shown here in a Mills Cross arrangement 120, include a transmitter or projector array 130 and a receiver or hydrophone array 140. Projectors in the projector array may be spaced along a line that is parallel with a keel line or track of a vehicle or vessel to which they are mounted which may be referred to as an along track arrangement. In some embodiments, a receiver of the transceiver 122 has an operating frequency range matched with that of the projectors and/or the hydrophones.

[028] During echo sounder operation, sound or pressure waves emanating

from the projector array travel within a body of water and possibly within the bottom beneath the body of water and in doing so may undergo interactions, such as reflections or scattering, which disturb the propagation trajectory of the pressure waves. Some of the reflections or echoes are “heard” by the hydrophone array. See for example the disclosure of Etal, U.S. Pat. No. 3,144,631, which is included herein by reference, in its entirety and for all purposes.

[029] The acoustic transceiver 122 includes a transmitter section 150 and a receiver section 170. The acoustic transceiver may be configured to transmit to a single projector array 130 and to receive from a single hydrophone array 140. In some embodiments, such a transceiver may be said to operate with a single transmitter array and a single receiver array. Unless otherwise noted, the term transceiver does not require common transmitter and receiver packaging.

[030] In various embodiments, a single projector array ensonifies the entirety of a swath on a single ping. Here, a projector array may be a single projector array regardless of the geometry, arrangement, or quantity of devices employed. For example, where a plurality of projectors forms a plurality of spatially distinct projector groups, the plural projectors are a single projector array if they are operated to ensonify the entirety of a swath on a single ping.

[031] The echo sounder may further include a means such as an interface module 124 for interconnection with the transceiver 122. This interface module may provide, among other things, a power supply for the transceiver, communications with the transceiver, communications with the workstation computer 126, and communications with other sources of data such as a source of contemporaneous GPS data.

[032] The workstation computer 126 may provide for one or more of data processing such as data processing for visualization of survey results, for data storage such as storage of bathymetry data and backscatter data, for user inputs, and for display of any of inputs, system status, and survey

results.

[033] Mills Cross Transducer Arrangement

[034] FIGS. 2A-B show an exemplary vessel equipped with a multibeam echo sounder 200A. See for example the echo sounders of FIGS. 1A-B. As seen in FIG. 2A, an MBES array package 204 is affixed to a vessel 202, for example to a bottom of the vessel.

[035] Within the array package 204 is an along track array of projectors 208 and a cross track array of hydrophones 210. The projector array is for excitation by an echo sounder transmitter message. The hydrophone array is for receiving echoes of the transmitted message.

[036] As explained below, a crossed array arrangement such as a Mills Cross arrangement of the projector and hydrophone arrays enables the echo sounder to operate with crossed transmit and receive beams wherein the cross intersection identifies a particular waterbody location, area, or cell. The crossed arrays may be in a perpendicular or a substantially perpendicular arrangement. Substantially perpendicular refers to generally small deviations from perpendicular caused by any of array assembly tolerances, mounting tolerances, adjustment tolerances, and the like.

[037] Echoes Returned From Particular Locations

[038] FIG. 2B shows bottom ensonification 200B. In particular, an across track strip or fan of a waterbody bottom 212 is ensonified by the projector array 208. Note the along track projector array 208 ensonifies an across track fan 212. As shown, the projected beam 211 has a wide across track aperture angle θ_{t1} as compared with a relatively narrow along track aperture angle θ_{t2} . Echoes from this ensonified fan are received by the hydrophone array 210.

[039] In various embodiments, MBES receiver beam steering enables subdivision of the fan 212 into a series of zones. This subdivision into zones enables identification of an echo returned from a particular zone or

location 213 on the waterbody bottom 215.

[040] Survey Perspectives

[041] Notably, when the fan 212 is ensonified, the vessel is in a particular position relative to the waterbody bottom 215. As such, the echo returned from the waterbody bottom location 213 may be said to have been acquired from a particular perspective with the MBES in a particular position relative to the waterbody bottom location.

[042] As discussed below, when echo data for a particular waterbody bottom location includes data from multiple different perspectives, this data can be used to test assumptions made about the environment that propagates the echoes.

[043] Echoes From Multiple Perspectives

[044] Multi-perspective ensonification includes a process of operating MBES projectors at multiple vessel locations such that a site on the waterbody bottom is ensonified multiple times from multiple different perspectives.

[045] For example, when the MBES projectors are operated at location (longitude 1, latitude 1), echo data ed1 from a zone z1 within the ensonified area is acquired. Later in time, when the MBES projectors are operated at location (longitude 2, latitude 2), echo data ed2 from a zone z2 that overlaps zone z1 may be acquired.

[046] Where zones z_1 and z_2 are at least partially superimposed, an overlap is defined. The site may be ensonified from multiple perspectives and echo data may be acquired from multiple perspectives. In some embodiments, different perspectives result when the MBES pitch angles ensonifying zones z_1 and z_2 differ.

[047] Various terminology may be used to refer to this and similar processes. For example, acquiring multiple echoes from the same site may be referred to as a part of a multi-perspective survey, multi-echo ray tracing, multi-look echo sounding, and/or multi-perspective ensonification,

echoes, or queries.

[048] Survey Plans

[049] FIGS. 2C-D show an antiparallel track survey plan aimed at acquiring multi-perspective survey data 200C-D.

[050] As shown in FIG. 2C, an MBES transducer plane $x-z$ is at level y_t and a waterbody bottom 215 plane $x'-z'$ is at level y_b . Survey vessel tracks are located in the upper $x-z$ plane. As shown, the survey vessel movement along a first track Track 1 is parallel to and opposite of survey vessel movement along a second track Track 2. In some embodiments, deviations from parallel tracks arise from vessel instrument measurement inaccuracies, course and or heading errors arising from sea conditions, and the like. In some embodiments similar multi-perspective survey results are provided by non-opposed track directions.

[051] Operation of MBES projectors on a vessel traversing Track 1 may, with a beam angle of θ_{t1} , ensonify a first waterbody bottom fan f_1 . And, operation of the MBES projectors while traversing Track 2 may, with a beam angle of θ_{t11} , ensonify a second waterbody bottom fan f_2 . The beam angles may be equal or not.

[052] Notably, when fan f_1 overlaps fan f_2 a portion of the waterbody bottom is ensonified twice. As explained below, a first ensonification from Track 1 is from a first perspective and a second ensonification from Track 2 is from a second perspective.

[053] As shown in FIGS. 2C-D, MBES operation on Track 1 results in ensonification of fan f_1 which includes ensonification of cell c_1 and ensonification A_p of a site within cell c_1 . In similar fashion, MBES operation on Track 2 results in ensonification of fan f_2 which includes ensonification B_p of the same site within cell c_2 . Temporally, ensonification A_p and its echo A_h may precede ensonification B_p and its echo B_h .

[054] This example shows an antiparallel track survey plan where a site

defined by an overlap (an overlap, site, or overlap site) is ensonified from a first perspective on Track 1 and from a second perspective on Track 2. In particular, the first perspective is the location of g_1 on Track 1 relative to the overlap site and the second perspective is the location of g_2 on Track 2 relative to the overlapped.

[055] FIGS. 2E-F show a cross track survey plan aimed at acquiring multi-perspective survey data 200E-F.

[056] As shown in FIG. 2E, an MBES transducer plane $x-z$ is at level y_t and a waterbody bottom 215 plane $x'-z'$ is at level y_b . Survey vessel tracks, Track 1 and Track 2, are located in the upper $x-z$ plane. As shown, the tracks cross at an angle α . In some embodiments, angle α is about a right angle with deviations subject to vessel instrument measurement inaccuracies, course and or heading errors arising from sea conditions, and the like. In various embodiments the survey vessel direction of movement along either track may be reversed.

[057] Operation of MBES projectors on a vessel traversing Track 1 may, with a beam angle of θ_{t1} , ensonify a first waterbody bottom fan f_1 . And, operation of the MBES projectors while traversing Track 2 may, with a beam angle of θ_{t11} , ensonify a second waterbody bottom fan f_2 . The beam angles may be equal or not.

[058] Notably, when fan f_1 overlaps fan f_2 a portion of the waterbody bottom is ensonified twice. As explained below, a first ensonification from Track 1 is from a first perspective and a second ensonification from Track 2 is from a second perspective.

[059] As shown in FIGS. 2E-F, MBES operation on Track 1 results in ensonification of fan f_1 which includes ensonification of cell c_1 and ensonification A_p of a site within cell c_1 and a corresponding echo A_h . In similar fashion, MBES operation on Track 2 results in ensonification of fan f_2 which includes ensonification B_p of the same site within cell c_2 and a corresponding echo B_h . Temporally, ensonification A_p and its echo A_h may precede ensonification B_p and its echo B_h .

[060] This example shows a cross track survey plan where an overlap site is ensonified from a first perspective on Track 1 and from a second perspective on Track 2. In particular, the first perspective is the location of g1 on Track 1 relative to the overlap site and the second perspective is the location of g2 on Track 2 relative to the overlap site.

[061] FIGS. 2G-H show a same track survey plan aimed at acquiring multi-perspective survey data 200G-H.

[062] As shown in FIG. 2G, an MBES transducer plane x-z is at level yt and a waterbody bottom 215 plane x'-z' is at level yb. Survey vessel Track 1 is located in the upper x-z plane. In some embodiments, Track 1 is a straight line. And, in some embodiments Track 1 deviates from a straight line. For example, where Track 1 is about a straight line, deviations from a straight line path include deviations due to vessel instrument measurement inaccuracies, course and or heading errors arising from sea conditions, and the like. In various embodiments the survey vessel direction of movement along the track may be reversed.

[063] An early operation of MBES projectors on a vessel traversing Track 1 may, with a cross track beam angle of θ_{t1} , ensonify a first plurality of waterbody bottom fans f1-f5. As shown, the fans f1-f5 extend between an along track angle β_{t1} .

[064] A later operation of the MBES projectors while traversing Track 1 may, with a beam angle of θ_{t11} , ensonify a second plurality of waterbody bottom fans f1'-f5'. As shown, the fans f1'-f5' extend between an along track angle β_{t11} . The angles θ_{t1} , θ_{t11} may be equal or not. The angles β_{t1} , β_{t11} may be equal or not.

[065] As shown, the early MBES projector operation produces a grid of cells located by fan f1-f5 and by zone k1-k4. For example a cell f1, k1 is ensonified by early MBES operation while a cell f5', k1 is ensonified by later MBES operation. These cells do not overlap.

[066] In another example a cell f4, k1 is ensonified by early MBES

operation while the same cell $f1'$, $k1$ is ensonified by later MBES operation. These cells overlap. As explained below, early MBES operation and later MBES operation provides ensonification of cell $f4$, $k1$ from a first perspective at $g1$ along Track 1 and ensonification of overlapping cell $f1'$, $k1$ from a second perspective at $g2$ along Track 1.

[067] As shown in FIG. 2H, early MBES operation on Track 1 at $g1$ results in ensonification of fans $f1$ - $f5$ which includes ensonification A_p of cell $f4$, $k1$ and a corresponding echo A_h . Later MBES operation on Track 1 at $g2$ results in ensonification of fans $f1'$ - $f5'$ which includes ensonification B_p of cell $f1'$, $k1$ and a corresponding echo B_h . Temporally, ensonification A_p and echo A_h may precede ensonification B_p and echo B_h .

[068] This example shows a same track survey plan where a site is ensonified from a first and a second perspective along Track 1. In particular, the first perspective is the location of $g1$ on Track 1 relative to the overlap site and the second perspective is the location of $g2$ on Track 1 relative to the overlap site.

[069] **Waterbody Model**

[070] Estimating the propagation path(s) of acoustic energy through a waterbody may be referred to as ray tracing. This ray tracing may involve dividing the waterbody into layers. Tracing sound rays through a body of water may involve dividing the waterbody into layers. With defined layers, physical properties such as the speed of sound may be measured, estimated, or otherwise made available for one or more layers. The value of a particular media property may be held constant or varied, such as linearly varied, within a layer. For example, in a multi-layer media model the speed of sound may be constant within a layer or change with a constant gradient within a layer provided the speed of sound is continuous from layer to layer.

[071] FIGS. 2I-J show an exemplary waterbody model 200I-J. As seen, the waterbody includes three layers ($l1$, $l2$, $l3$), each layer having a corresponding thickness ($t1$, $t2$, $t3$). In each of the figures, four interfaces

with corresponding sound speeds (c_1, c_2, c_3, c_4) and (c_1', c_2', c_3', c_4') demarcate the layers.

[072] FIG. 2I shows a first echo from a point on a waterbody bottom 283 that is traced with three ray segments. In accordance with Snell's law of refraction ($\sin \theta_x/c_x = \sin \theta_y/c_y$), a first ray segment r_a exits layer l3 at an angle θ_3 , a second ray segment r_b exits layer l2 at an angle θ_2 , and a third ray segment r_c exits layer l1 at an angle θ_1 . In various embodiments, the third ray segment r_c leaves layer l1 at or near an MBES hydrophone array.

[073] As skilled artisans will appreciate, ray segments like those of FIGS. 2I-J may travel through a layer and/or be modeled as traveling through a layer with no change in sound speed or with various changes in sound speed. For example, sound may travel through a layer with a constant sound speed and experience no change of ray path angle resulting in a straight ray segment. For example, sound may travel through a layer with a constant sound speed gradient and experience a gradual change of ray path angle resulting in a curved ray segment. Notably, the figures do not attempt to replicate curved ray segments. For example, in some embodiments ray angles at layer interfaces may change abruptly with gradual continuous changes thereafter as in a prior layer. For example, in some embodiments the slopes of adjoining rays at layer interfaces may be equal or about equal, for example within 1 to 10 percent difference.

[074] FIG. 2J shows a second echo from the point 283 on the waterbody bottom. Here, a first ray segment r_a' exits layer l3 at an angle θ_3' , a second ray segment r_b' exits layer l2 at an angle θ_2' , and a third ray segment r_c' exits layer l1 at an angle θ_1' . In various embodiments, the third ray segment leaves layer l1 at or near an MBES hydrophone array.

[075] As will be noted, the ray segments tracing the first echo are characterized by a more severe slope than those tracing the second echo. This shows, among other things, that the first and second echoes from the point on the waterbody bottom 283 correspond to ensonifications from

different perspectives as discussed above.

[076] It should be noted that FIGS. 2I-J are based on a particular waterbody model and are merely illustrative. For example, the number of layers used in the model may be 2, 3, 4, 5 or more. For example, the value of the speed of sound may vary with depth.

[077] **Testing Sound Speeds**

[078] FIGS. 3A-3G show a process for testing sound speeds used in depth estimates 300A-G.

[079] FIG. 3A provides an overview of the process 300A. In a first step, a model of the waterbody where sound speeds at various depths will be estimated is constructed. See for example the models of FIGS. 2I-J. In a second step, a survey path is selected. See for example the survey paths of FIGS. 2A-H and in particular survey paths that provide multi-perspective ensonifications of individual overlap sites. In the third step 330, survey data is acquired when an MBES is operated on board a vessel that follows the selected survey path. From this data, waterbody bottom reflectors are located in a fourth step.

[080] Because it is unlikely that multiple echoes will emanate from the same reflector, groups of reflectors in relatively small areas on the waterbody bottom are assumed to be colocated and to provide multi-perspective echoes from the same location. For example, the waterbody bottom may be divided using a square grid into colocation areas that are one meter on a side. Notably, grid size may vary with water depth owing to beam footprints that vary with depth.

[081] In step 350, colocated reflectors are identified using a method such as the one just described. Because colocated reflectors are found in a small area on the waterbody bottom, the depth estimate made for each of the reflectors should be closely similar or, perhaps within measurement accuracy, the same. Notably, reducing the grid size reduces the variation in actual depths among a group of colocated reflectors.

[082] With the assumption that depths among colocated reflectors should be the same, in a sixth step 360 disagreements in depth estimates are characterized in a quantitative manner. In step seven 370, the sensitivity in depth disagreements to sound speed perturbations is quantified. In step eight 380, the depth estimate disagreements are reduced or minimized by selecting speed of sound values that achieve this result. In an embodiment, the process ends thereafter at step 390.

[083] FIGS. 3B-3G which follow provide a flowchart with process step details 300B-G.

[084] **Modeling The Environment**

[085] In FIG. 3B, the flowchart starts with modeling the environment in step 310. As shown alongside the flowchart, a waterbody model 312 provides four layers l1-l4 with respective layer thicknesses t_1-t_4 . The sound speeds entering and leaving the waterbody are c_1 and c_5 while the sound speeds at layer boundaries are c_2-c_4 . Angles of refraction entering each layer are $\theta_1-\theta_4$ and the angle of refraction leaving layer l4 is θ_5 .

[086] As skilled artisans will appreciate, ray segments like those of the waterbody model 312 may travel through a layer and/or be modeled as traveling through a layer with no change in sound speed or with various changes in sound speed. For example, sound may travel through a layer with a constant sound speed and experience no change of ray path angle resulting in a straight ray segment. For example, sound may travel through a layer with a constant sound speed gradient and experience a gradual change of ray path angle resulting in a curved ray segment. Notably, the figures do not attempt to replicate curved ray segments. For example, in some embodiments ray angles at layer interfaces may change abruptly with gradual continuous changes thereafter as in a prior layer. For example, in some embodiments the slopes of adjoining rays at layer interfaces may be equal or about equal, for example within 1 to 10 percent difference.

[087] A table alongside the flowchart 314 includes selected variables and

their descriptions.

[088] Known variables in the table are travel time tt for an acoustic message emitted by the projectors 208 and received by the hydrophones 210, sound speed at the launch $c1$, launch angle $\theta1$. User defined variables are the thicknesses $t1-t3$ of layers of waterbody layers $l1-l3$.

[089] Initially estimated variables in the table are sound speeds $c2-c5$ and angles of refraction $\theta2-\theta5$. The unknown variable in the table is the thickness of layer $l4$.

[090] **Selecting Survey Path**

[091] FIG. 3C is a continuation 300C of the flowchart of FIG. 3B as indicated by link $f1$. In step 320 a survey path is selected. As shown alongside the flowchart, the survey path selected is an antiparallel track path 322. Track B overlaps Track A, the direction of Track B being opposite the direction of Track A.

[092] As discussed above, with this survey path the ensonification of a Track A cell 325 and the subsequent ensonification of an overlapping Track B cell 327 is intended to provide echoes from multiple perspectives. In particular, echoes resulting from the first ensonification of colocated reflectors are from a perspective other than that of echoes resulting from the second ensonification of the colocated reflectors.

[093] Concerning selection of an antiparallel tracks survey path, the discussion above shows any of several survey paths might be selected including parallel tracks in the same or opposed directions, cross tracks in similar or opposed directions, and same track forward and backward look directions. Further, any combinations of these paths may be chosen to provide multiple echoes from differing perspectives from each of plural reflectors.

[094] Notably, while this discussion speaks of echoes from multiple, e.g., two different, perspectives, a group of colocated reflectors may return echoes from many different perspectives.

[095] Acquiring Data

[096] An acquired data step 330 includes an ensonification step 332 where multiple “i” areas (A_i, A₂... A_i) are ensonified with “i” pings (P₁, P₂... P_i) to obtain echoes from “i” perspectives. Also included is a receive returns step 334 where waterbody bottom reflectors return echoes from these pings and round trip travel times of those echoes are measured for all beams, fans, and pings.

[097] As shown alongside the flowchart, an example with i = 3 is shown. For illustrative purposes the waterbody bottom areas A₁, A₂, A₃ are shown as circles. Reflectors located in the common area “Z” where the three circles overlap will return echoes from three different perspectives.

[098] Notably, what is presented here is exemplary. For example, just as two areas may provide an intersecting zone z, so too may many more than two or three overlapping areas provide an intersecting zone.

[099] Ray Tracing To Determine Reflector Locations

[0100] Given measured travel time information and the modeled sound speed profile, in step 340 acoustic paths through the layers of the waterbody model 312 between the MBES and ensonified reflectors are modeled. Within each of the areas A₁, A₂, A₃ ray tracing to reflectors provides coordinates x, y, z specific to each reflector. As shown, matrices 326 for respective areas PA₁, PA₂, PA₃ provide coordinates for reflectors therein. Here, seven or more sets of reflector coordinates appear in each matrix and indicate returns from corresponding reflectors in each of the areas. Coordinate indicia indicate a reflector number (e.g., 1-7) and an area that confines the reflector (e.g., A₁, A₂, A₃).

[0101] Finding Colocated Reflectors

[0102] FIG. 3D is a continuation 300D of the flowchart of FIG. 3C as indicated by link f2. Here, groups of reflectors may be considered as “colocated” or as representative of a single location on a waterbody bottom such as a location having a single or substantially invariant depth such as

a depth that varies within a survey map tolerance, survey instrument tolerance, selected tolerance, or similar industry tolerance.

[0103] A step of finding colocated reflectors 350 includes an identification step 352, a collection step 354, and a rewrite step 356.

[0104] In the identification step 352, colocated reflectors are identified as reflectors having the same or similar x, y coordinates across all three of the matrices PA1, PA2, PA3 are marked 353.

[0105] In particular, as shown by the dotted box outlines, coordinate pairs $x_{2,A1}$, $y_{2,A1}$ and $x_{5,A2}$, $y_{5,A2}$ and $x_{1,A3}$, $y_{1,A3}$ identify a 1st same or similar waterbody bottom location. As shown by dashed box outlines, coordinate pairs $x_{6,A1}$, $y_{6,A1}$ and $x_{7,A2}$, $y_{7,A2}$ and $x_{4,A3}$, $y_{4,A3}$ identify a 2nd same or similar waterbody bottom location. And, as shown by dashed and dotted box outlines, coordinate pairs $x_{4,A1}$, $y_{4,A1}$ and $x_{3,A2}$, $y_{3,A2}$ and $x_{6,A3}$, $y_{6,A3}$ identify a 3rd same or similar waterbody bottom location.

[0106] Reflector coordinates may be said to identify a similar location when they are situated within a selected colocation area, for example within an area of one square meter. Reflector coordinates may be said to identify a similar location when they lie within a colocation circle, for example a circle having a diameter of one meter. Similarly located reflectors may be identified by overlaying and dividing the waterbody bottom with a pattern such as a grid, regular grid, or square grid and designating each area so identified as a colocation area. For example, where a regular grid such as a square grid is used, areas identified within the grid may be colocation areas such that reflectors falling within a particular grid defined area are colocated reflectors with similar x, y coordinates.

[0107] In the collection step 354, the coordinates of similarly located reflectors are collected 355 in three matrices CP1, CP2, CP3. As suggested by the coordinate indices below the matrices, a simplification in matrix presentation results from rewriting the indices in a manner suggesting that for a given matrix the x,y coordinates are the same or similar.

[0108] In the rewriting step 356 illustrated by three matrices 357, the multiple collocated x and y coordinates of the matrices 355 are assigned a single x and y value to represent the group, for example using an average, grid center or area center. See in particular indices of x, y, z, are rewritten in matrices CPT1, CPT2, CPT3 that correspond to matrices CP1, CP2, CP3. Here, remarking the indices of x and y to be the same within a given matrix emphasizes the equality or similarity of the x, y pairs in the matrix, for example x_1, y_1 for all of the x, y pairs in matrix CPT1.

[0109] Notably, the z coordinates are not necessarily equal or similar. As such, they are remarked as $z_{a,b}$ where “a” is constant in a particular matrix and “b” varies from row to row in the matrix. For example, in the first matrix CPT1 the z coordinates by row are $z_{1,1}, z_{1,2}, z_{1,3}$.

[0110] In each of the rewritten matrices CPT1, CPT2, CPT3 a respective location x, y corresponds with three different depth estimates. For example, in CPT1 the location x_1, y_1 corresponds with depth estimates $z_{a,1}, z_{a,2}, z_{a,3}$.

[0111] **Solution Paradigms**

[0112] In various embodiments, we may assume the depth estimates in each matrix 357 should be the same even though they are not. Equality may be assumed because, for each matrix, the depth estimates correspond with a group of collocated reflectors. As such, the depth estimates in a particular matrix may be viewed as samples or sample values “s” of the same environmental variable at a particular location.

[0113] The goodness of this same matrix/same depth assumption depends on variables including the regularity of the waterbody bottom and the characteristic dimension(s) and/or pattern(s) used to identify collocated reflectors.

[0114] Whatever the case, various methodologies for testing and/or improving depth estimates may manipulate variables such as sound speed(s) to reduce the variability in depth estimates for each group and/or

multiple groups of colocated reflectors.

[0115] Characterizing Disagreements In Depth Estimates

[0116] FIG. 3E is a continuation 300E of the flowchart of FIG. 3D as indicated by link f3. Here, a step of characterizing disagreement in depth estimates includes a step establishing a basis to characterize differences 360 and the step of characterizing the disagreement 362.

[0117] In particular, step 360 establishes a basis for characterizing differences in depth estimates. For each group of colocated reflectors a mean value matrix **z** as shown below expresses this basis.

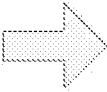
Mean Value Equation	Variables	Variable description
$\bar{z}_x = (\sum_{y=1}^s z_{x,y})/s$ 	\bar{z}_x	mean depth for each group x of colocated reflectors
	$z_{x,y}$	depth at y th reflector in group x of colocated reflectors
	s	number of samples

[0118] Given a basis for characterizing differences in depth estimates, step 364 provides for each group of colocated reflectors a measure of the disagreement among depth estimates as expressed by vector **d** shown in the equation below.

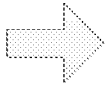
Disagreement Equation	Variables	Variable description
$d_x = (\sum_{y=1}^s z_x - z_{x,y})/s$ 	d	disagreement in depth estimate for each group x of colocated reflectors (residuals)
	\bar{z}_x	mean depth for each group x of colocated reflectors
	$z_{x,y}$	depth at y th reflector in group x of colocated reflectors

	s	number of samples
--	---	-------------------

[0119] Constructing A Gradient Matrix

[0120] FIG. 3F is a continuation 300F of the flowchart of FIG. 3E as indicated by link f4. The gradient matrix is a metric of the sensitivity of depth estimates to modeled sound speeds and is constructed by first perturbing the values of sound speed $c_2 \dots c_p$ by a positive increment and then by a negative increment. Then, for each perturbation, steps are repeated including the steps of determining reflector locations 340, finding colocated reflectors 350, and characterizing disagreements in depth estimates 360 with vectors \mathbf{d}_+ and \mathbf{d}_- .

[0121] In step 371, a counter p counts from 2 to 5 indicating values of the speed of sound $c_2 \dots c_5$ consistent with a four layer waterbody model having five corresponding values of the speed of sound $c_1 \dots c_5$ where c_1 is a known value of the speed of sound at the launch.

[0122] In step 372, a positive perturbation $(+\Delta)$ is applied to a p^{th} sound speed value c_p . Steps 340-364 are repeated and vector \mathbf{d}_{p+} is populated 376. The p^{th} sound speed value c_p is then reset.

[0123] In step 373, a negative perturbation $(-\Delta)$ is applied to the p^{th} sound speed value c_p . Steps 340-364 are repeated and vector \mathbf{d}_{p-} is populated 377. The p^{th} sound speed value c_p is then reset.

[0124] In step 374, a p^{th} row of the gradient matrix \mathbf{G} is populated. In particular, $G_{p,i} = (d_{p+,i} - d_{p-,i}) / 2 \text{ mag}(\Delta)$ where counter i varies from 1 to n to populate 378 the columns of the matrix \mathbf{G} , each value of i representing the i^{th} group of colocated reflectors. When the last column is populated, counter p indexes to the next value in step 375 and steps 372-374 are repeated. When the last row of the matrix \mathbf{G} is populated, the process proceeds to step 382 of the minimize disagreement block 380.

[0125] Minimizing Depth Estimate Disagreement

[0126] FIG. 3G is a continuation 300G of the flowchart of FIG. 3F as indicated by link f5. In this figure, disagreements among depth estimates in each group of colocated reflectors are simultaneously minimized utilizing conventional least-squares techniques associated with linear algebra.

[0127] In step 382, an equation utilizing the gradient matrix **G** and disagreement in depth estimates vector **d** provides a vector of corrections **mhat** to be applied to sound speed values to reduce or minimize depth disagreements. The equation presented 382 is a well-known least-squares minimizing solution whose derivation is available in academic texts such as the text by Munk, Walter, et al., *Ocean Acoustic Tomography*, Cambridge University Press, 1995. The equation provides two terms for conveying prior information, if known, about the noise or solutions. The diagonal of matrix **R** can be populated with the relative sizes of noise variance associated with each observation in vector **d**. The diagonal of matrix **S** can be populated with the relative sizes of the elements of **mhat**.

Overdetermined System Equation	Variables	Variable description
$\hat{m} = (G^T R^{-1} G + S^{-1})^{-1} G^T R^{-1} d$	\hat{m} (mhat)	Vector of corrections to be applied to sound speed values $c_2 \dots c_5$.
	G ^T	Transpose of gradient matrix G (interchange of rows and columns)
	R	Matrix conveying information about data uncertainty.
	R ⁻¹	Inverse of R matrix
	G	Gradient matrix.
	S	Matrix conveying information about model parameter sizes.
	S ⁻¹	Inverse of S matrix
d	disagreement in depth estimate for each group x of colocated reflectors	

	(residuals)
--	-------------

[0128] In step 384, each of the sound speed values $c_2 \dots c_5$ is corrected using the correction vector **mhat**.

Sound Speed Estimates	Variables	Variable description
$c_{2est} = c_2 - \hat{m}_2$ $c_{3est} = c_3 - \hat{m}_3$ $c_{4est} = c_4 - \hat{m}_4$ $c_{5est} = c_5 - \hat{m}_5$	c	sound speed
	mhat	sound speed correction

[0129] Synthesizing A Sound Speed Profile

[0130] The above solution procedure is based on a multilayer waterbody model with a known sound speed c_1 at launch and initial estimates or otherwise available values of sound speed at the layer interfaces and at the waterbody bottom.

[0131] Notably, cases may arise where the only available value(s) of sound speed are sound speed value(s) at launch. For example, a survey conducted with equipment malfunction(s) or human error(s) may result in such a case. For example, a survey conducted with the intent to estimate sound speed values after the survey is conducted may result in such a case.

[0132] In some embodiments, the system and method of the present invention may be used to synthesize a sound speed profile. For example, where sound speed at launch is known, the system and method of the present invention may be used to synthesize a sound speed profile through a waterbody modeled with a plurality of layers.

[0133] FIG. 4 shows a method for synthesizing a sound speed profile where

a waterbody is modeled with multiple layers 400. Steps in this synthesis method corresponding to those mentioned above (see e.g., FIGS. 3A-G) may be carried out in a similar manner.

[0134] In a first step 410 the need for synthesizing a sound speed profile is evaluated. Where there is a need, the process proceeds to a second step 420.

[0135] In the second step 420, known variables are identified. In particular, knowns may be sound speed at a Mills Cross transducer array, launch angle, travel time, GPS data, and vessel heading/tilt/roll data. In a third step 430, the environment is modeled. Here, c_1 is known and for j layers the sound speed is set to c_1 such that in each layer the speed of sound is the same.

[0136] With a multilayer model, ray tracing locates reflectors in a fourth step 440. And, finding groups of colocated reflectors follows in a fifth step 450.

[0137] In step 460, i) disagreements in depth estimates are characterized in a manner similar to that described in step 360 above, ii) a gradient matrix is constructed in a manner similar to that described in step 370 above, iii) disagreements among depth estimates in each group of colocated reflectors are reduced in a manner similar to that described in step 380 above, iv) sound speed adjustments are calculated in a manner similar to that described in step 380 above, and v) sound speed adjustments are applied as suggested above. Using the adjusted values of sound speed, a survey may be created in step 470. Following step 470 is an end step 480.

[0138] In an embodiment, a threshold value that when compared to a function of the measured depth disagreements indicates whether the assumed sound speed profile differs from the real environment.

[0139] While various embodiments of the present invention have been described above, it should be understood that they have been presented by

way of example only, and not limitation. It will be apparent to those skilled in the art that various changes in the form and details can be made without departing from the spirit and scope of the invention. As such, the breadth and scope of the present invention should not be limited by the above-described exemplary embodiments, but should be defined only in accordance with the following claims and equivalents thereof.

CLAIMS

What is claimed is:

1. A multi-perspective ensonification method comprising the steps of:

installing a multibeam echo sounder system ("MBES") on a water going vehicle such that plural transducers in a single MBES projector array and plural transducers in a single MBES hydrophone array are in a Mills Cross arrangement;

modeling a waterbody with a plurality of "j" superposed layers ($l_1 \dots l_j$) having respective layer thicknesses ($t_1 \dots t_j$), each of the j layers having a layer entry sound speed and a layer exit sound speed such that a set of (j+1) sound speed values ($c_1, c_2 \dots c_{j+1}$) characterize the sound speed profile through the layers;

designing a vehicle route and traversing the route such that during MBES operation along the route i) plural primary areas are ensonified, ii) plural secondary areas are ensonified, iii) each primary area is overlapped by a respective secondary area, and iv) for each overlap a first echo originating therein traverses a first path to the MBES and a second echo originating therein traverses a second path to the MBES at a location different from the first;

via a travel time corresponding to each echo, modeling the propagation of sound through the waterbody to locate in three dimensions a reflector that returned the echo;

one of the dimensions indicating a waterbody depth and the other two dimensions indicating coordinates in a reflector plane parallel to the waterbody free surface;

selecting a colocation metric and using the metric to identify groups of reflectors that are collocated in the reflector plane;

for each group of collocated reflectors, quantifying disagreements in the waterbody depths corresponding to the reflectors in the group; and,

determining a set of adjusted sound speed values that tends to simultaneously reduce the disagreement within each group of depth estimates.

2. The method of claim 1 wherein the first echo path corresponds to a first beam angle and the second echo path corresponds to a second beam angle.

3. The method of claim 1 wherein the adjusted sound speed values are a function of disagreements in depth estimates evaluated at i) assumed sound speeds $(c_1, c_2 \dots)$ and at ii) perturbed values of assumed sound speeds $(c_1, c_2 \dots)_p$.

4. The method of claim 3 wherein non-intersecting first and second survey vessel tracks are chosen such that operating the MBES while traversing the tracks results in (i) at least partially superimposed first and second waterbody bottom fans that overlap at a site and (ii) multiple echoes from multiple colocated reflectors at the site.

5. The method of claim 3 wherein intersecting first and second survey vessel tracks are chosen such that operating the MBES while traversing the tracks results in (i) at least partially superimposed first and second waterbody bottom fans that overlap at a site and (ii) multiple echoes from multiple colocated reflectors at the site.

6. The method of claim 3 wherein MBES operation while traversing a single track results in (i) at least partially superimposed first and second waterbody fans that overlap at a site and (ii) multiple echoes from multiple colocated reflectors at the site.

7. The method of claim 6 wherein the first fan results from a forwardly pitched fan at time1 and the second fan results from rearwardly pitched fan at time2 where time2 > time1.

8. The method of claim 1 further comprising the step of operating the vehicle and the MBES to conduct a bathymetric survey.

9. The method of claim 8 further comprising the step of:
using the colocation metric, assigning each reflector to one of multiple zones that partition the reflector plane; and,
wherein reflectors assigned to the same zone are colocated reflectors.

10. The method of claim 9 wherein each of plural zones includes a respective group of 2 to 100 colocated reflectors.

11. The method of claim 10 wherein the zones have a characteristic dimension that is a function of a beam width and an altitude measured vertically between the MBES and a waterbody bottom.

12. The method of claim 10 wherein the zones have a characteristic dimension that varies proportionally with water depth.

13. The method of claim 8 wherein $j = 4$, c_1 is measured, and adjusted sound speed values include c_2, c_3, c_4, c_5 .

14. The method of claim 9 wherein the quantified disagreements in depth estimates are used to construct a system of simultaneous equations that is overdetermined, plural adjustments to respective sound speed values being indicated by a solution to the equations.

15. The method of claim 3 wherein the sound speed values are corrected using the one or more adjusted sound speed values.

16. The method of claim 3 wherein a portion of a bathymetric survey map is corrected when data used to make the map are used to find adjusted sound speed values and the survey map is recreated by replacing sound speed values in the data with adjusted sound speed values.

17. A synthetic sound speed profile creation method comprising the steps of:

providing MBES bathymetric data from a completed survey, the data including for each of multiple overlapping ensonified areas a first echo originating therein and a second echo originating therein, the first echo traversing a first path and the second echo traversing a second path;

modeling the surveyed waterbody with j superposed layers ($l_1 \dots l_j$), each of the layers having a layer entry sound speed and a layer exit sound speed such that a set of $(j+1)$ sound speed values ($c_1, c_2 \dots c_{j+1}$) characterize the sound speed profile through the layers;

setting the value of c_1 to a best estimate of c_1 and setting the values of c_2 through c_{j+1} to c_1 ;

estimating the three dimensional locations of waterbody bottom reflectors via ray tracing through the layers using the modeled sound speeds and survey data including launch angle, travel time, GPS data, and heading/tilt/roll data;

selecting a colocation metric and using the metric to identify groups of colocated reflectors;

for each group of colocated reflectors and respective reflector depth estimates, quantifying disagreements in the depth estimates;

determining a set of adjusted sound speed values that tends to reduce the depth estimate disagreements within each group of depth estimates; and,

using the adjusted sound speed values and MBES bathymetric survey data, creating a bathymetric survey map.

18. A method of warning that the assumed sound speed velocity profile is inaccurate, the method comprising the steps of:

installing a multibeam echo sounder system ("MBES") on a water going vehicle such that plural transducers in a single MBES projector array and plural transducers in a single MBES hydrophone array are in a Mills Cross arrangement;

modeling a waterbody with a plurality of "j" superposed layers ($l_1... l_j$) having respective layer thicknesses ($t_1... t_j$), each of the j layers having a layer entry sound speed and a layer exit sound speed such that a set of (j+1) sound speed values ($c_1, c_2... c_{j+1}$) characterize the sound speed profile through the layers;

designing a vehicle route and traversing the route such that during MBES operation along the route i) plural primary areas are ensonified, ii) plural secondary areas are ensonified, iii) each primary area is overlapped by a respective secondary area, and iv) for each overlap a first echo originating therein traverses a first path to the MBES and a second echo originating therein traverses a second path to the MBES at a location different from the first;

via a travel time corresponding to each echo, modeling the propagation of sound through the waterbody to locate in three dimensions a reflector that returned the echo;

one of the dimensions indicating a waterbody depth and the other two dimensions indicating coordinates in a plane parallel to the waterbody free surface;

selecting a colocation metric and using the metric to identify groups of reflectors that are colocated in the reflector plane;

for each group of colocated reflectors, quantifying disagreements in the waterbody depths corresponding to the reflectors in the group; and,

a threshold value that when compared to a function of the measured depth disagreements indicates whether the assumed sound speed profile differs from the real environment.

FIG. 1A

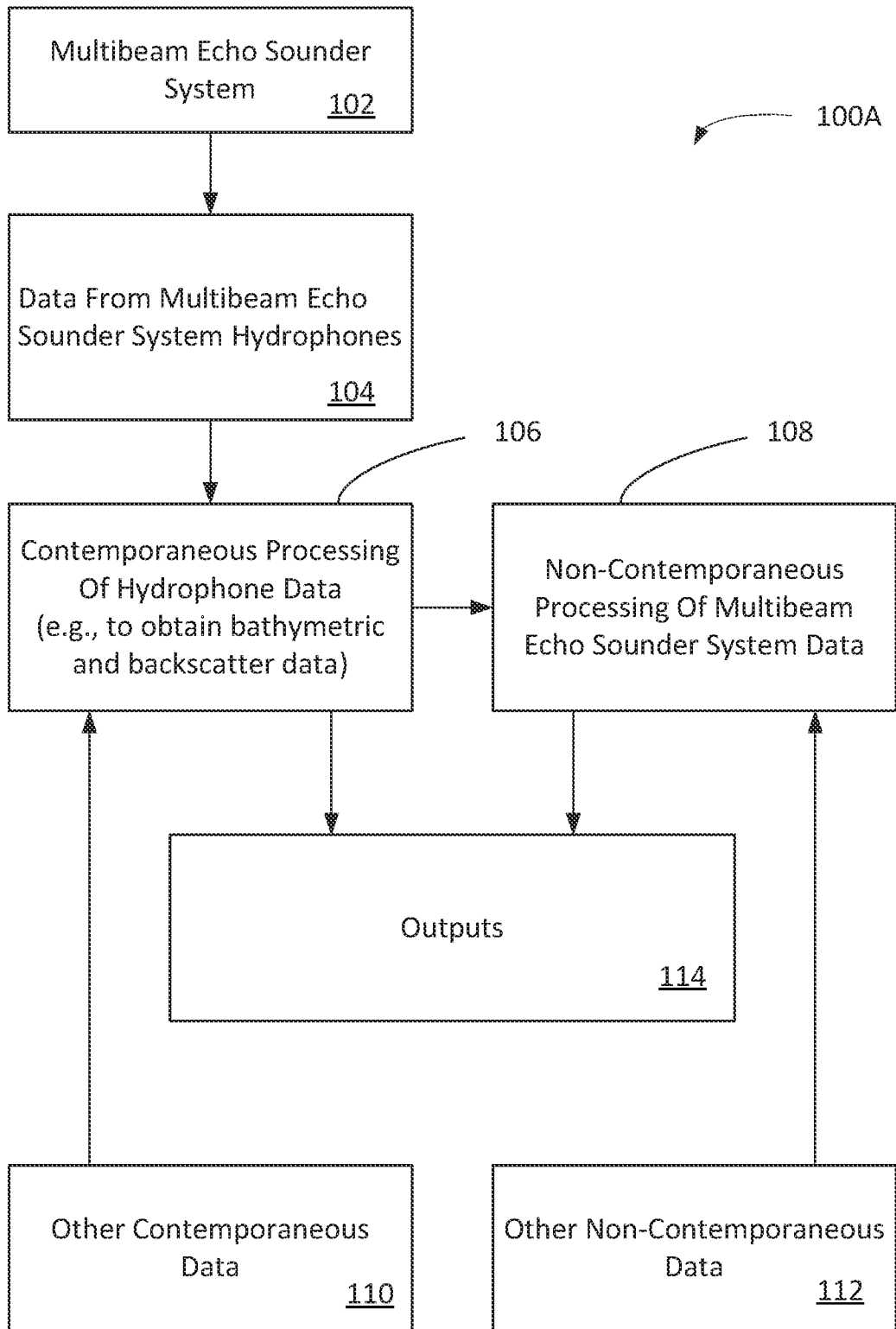

FIG. 1B

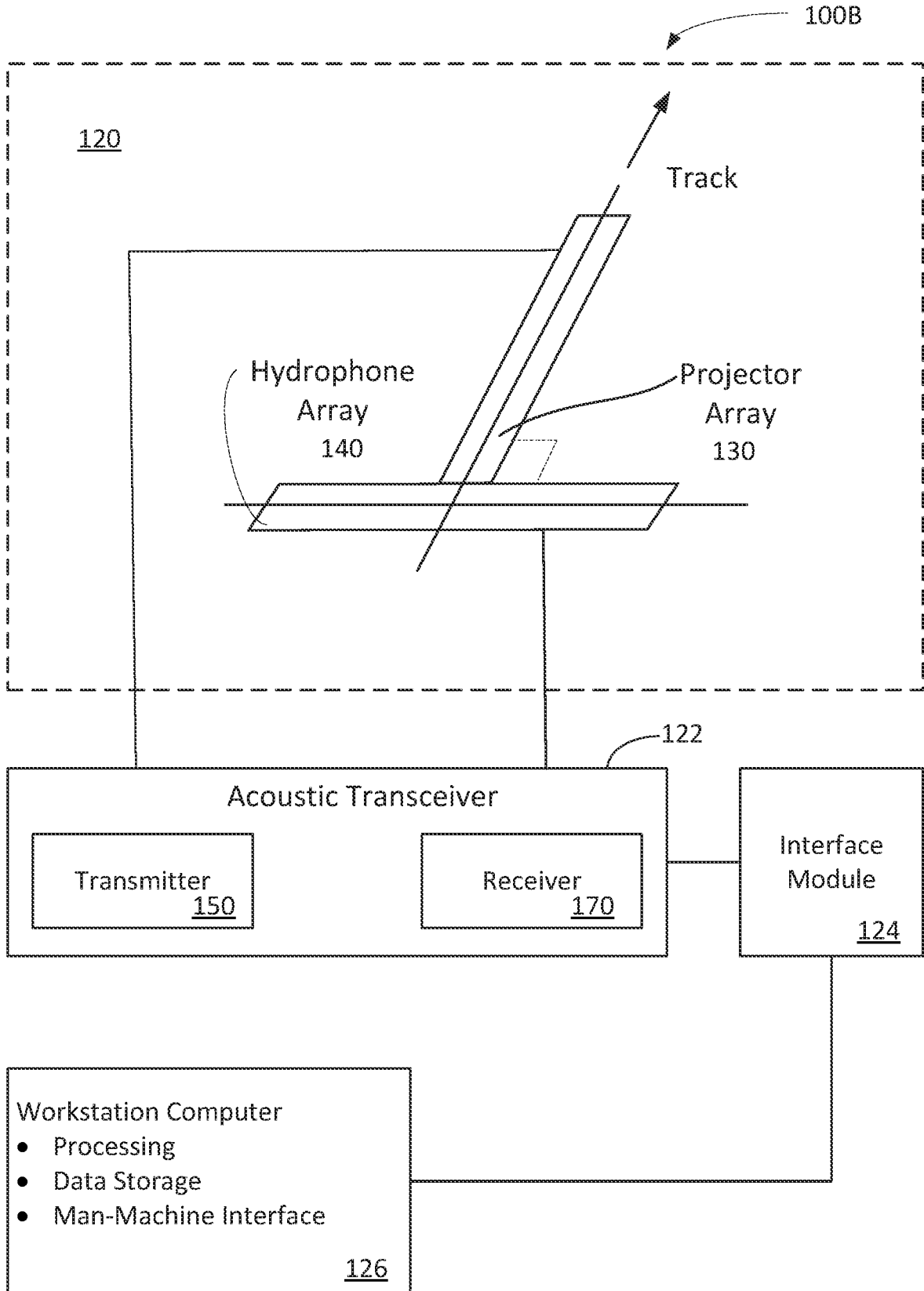

FIG. 2A

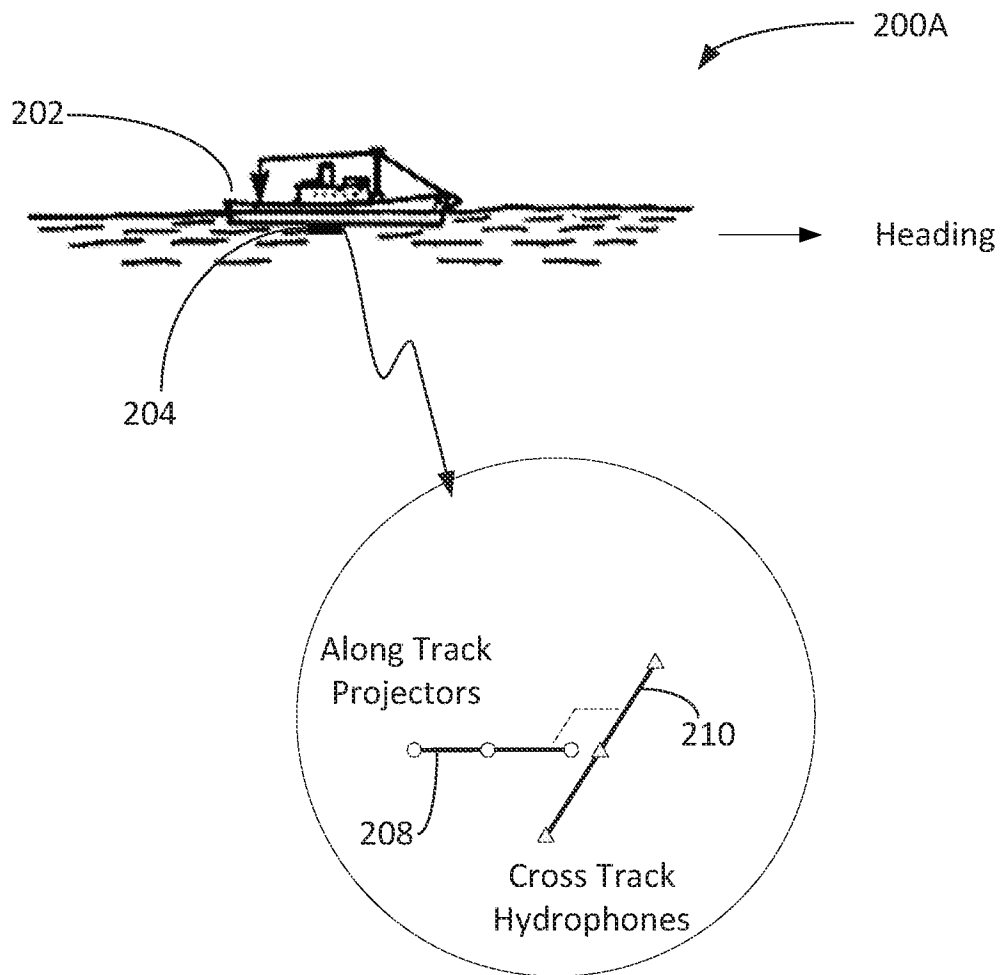

FIG. 2B

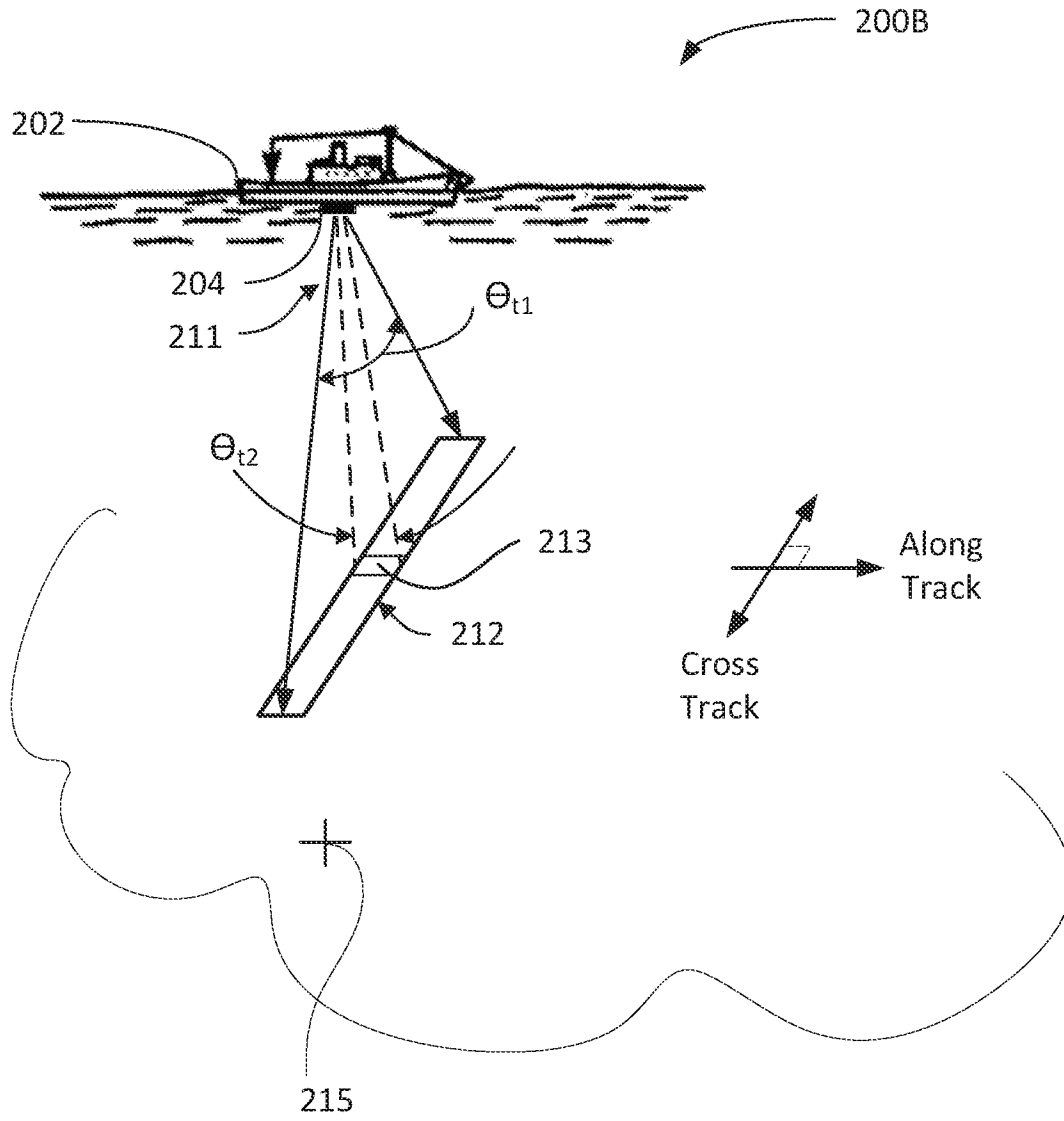

FIG. 2C

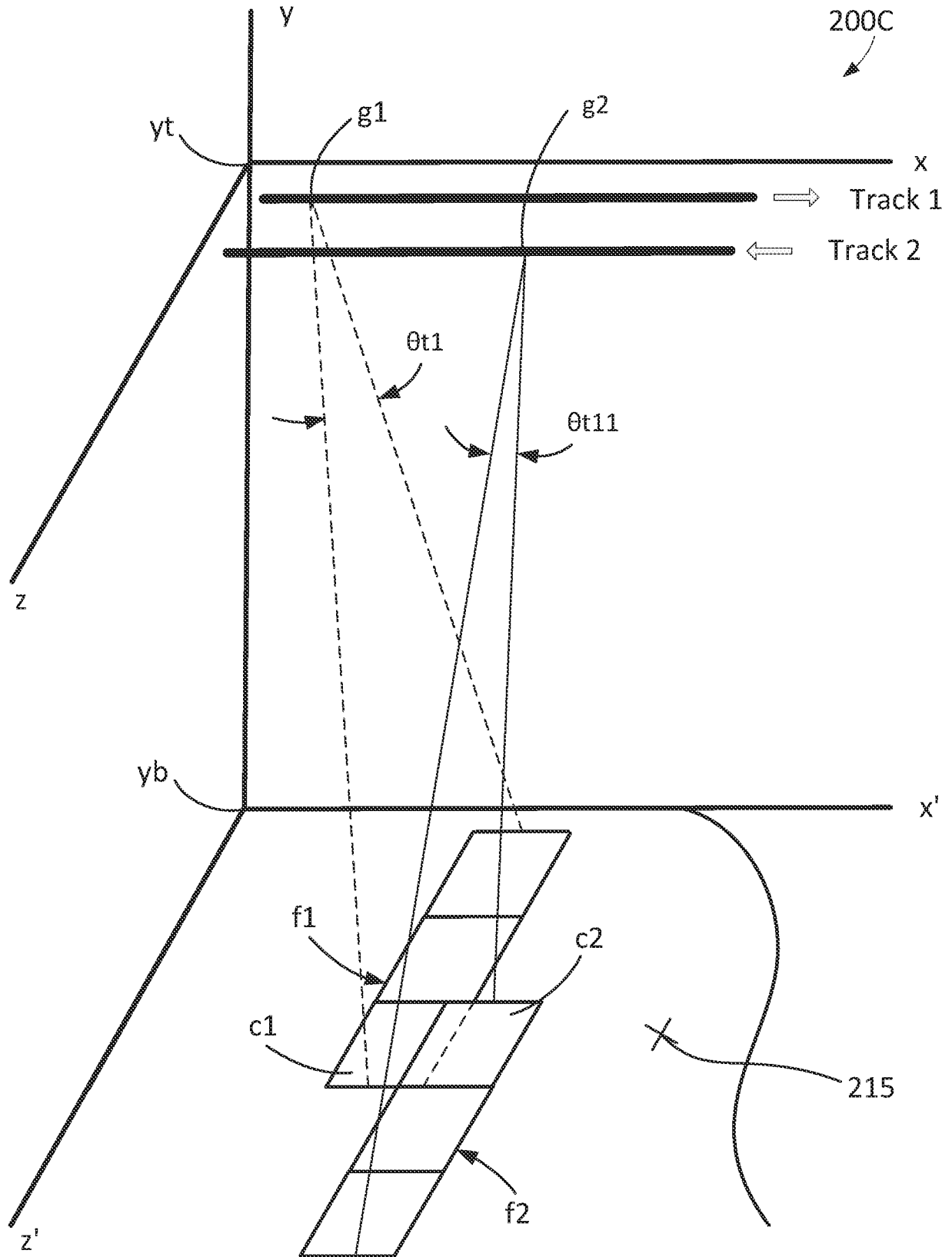

FIG. 2E

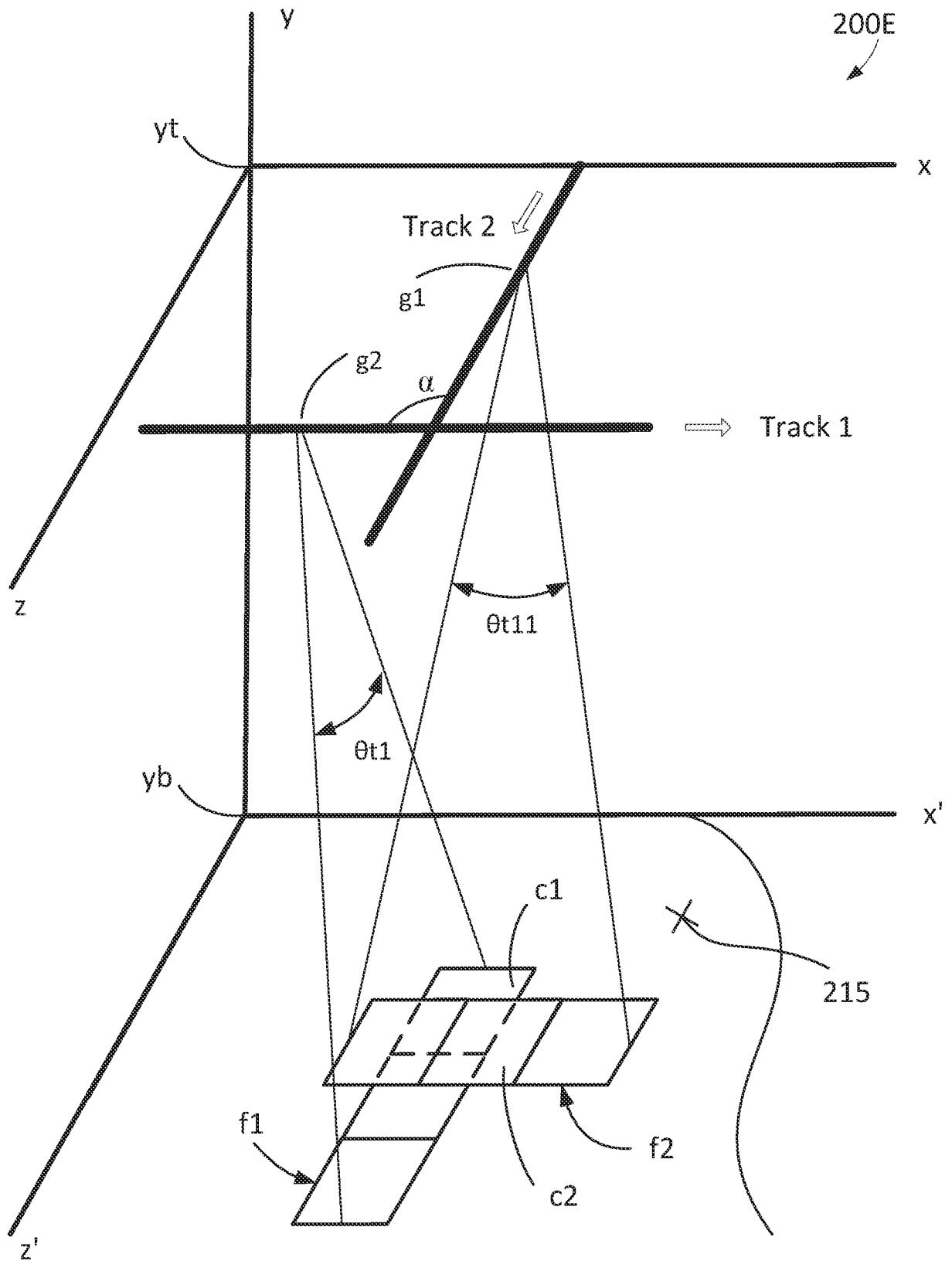

FIG. 2F

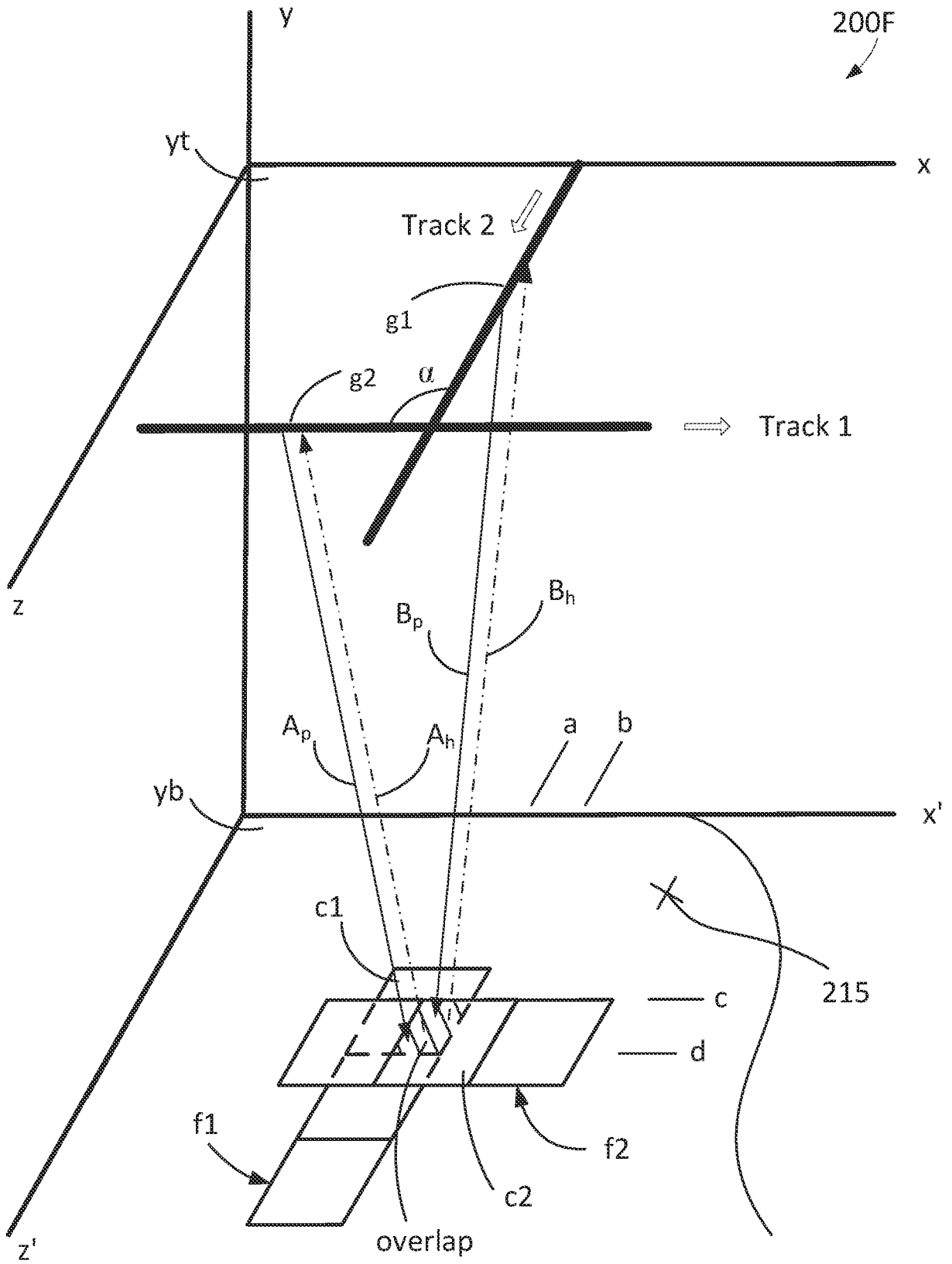

FIG. 2G

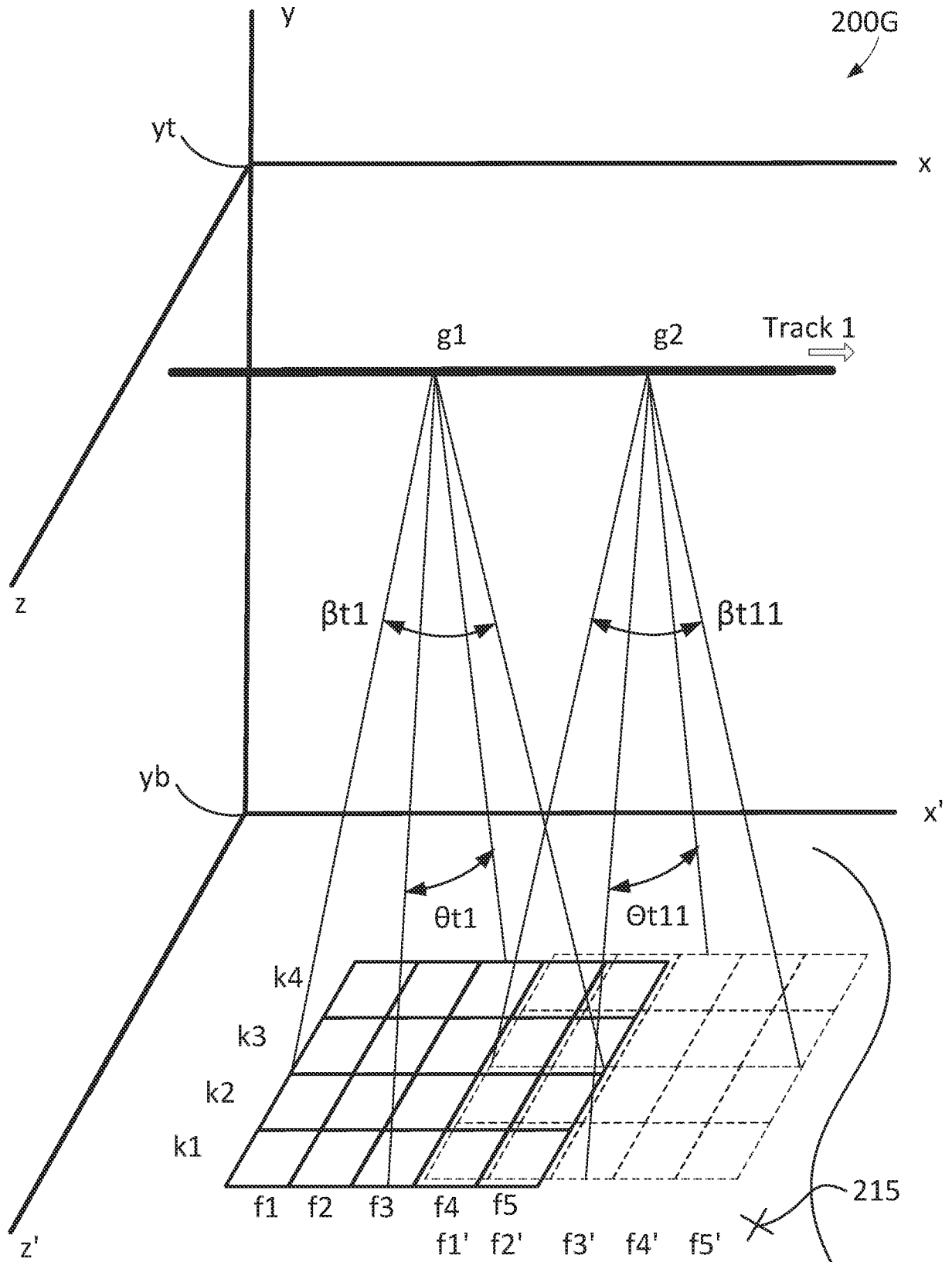

FIG. 2H

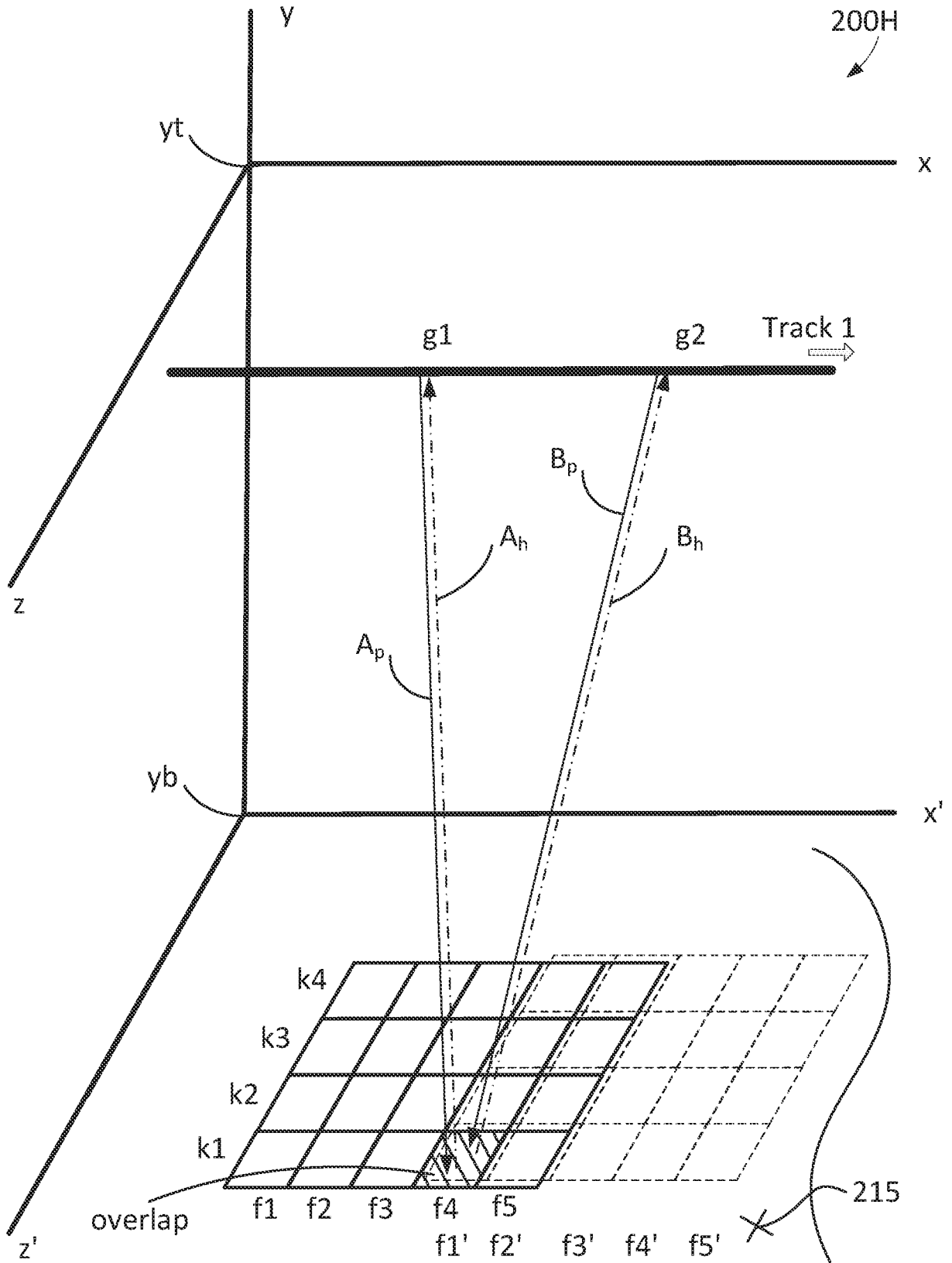

FIG. 2I

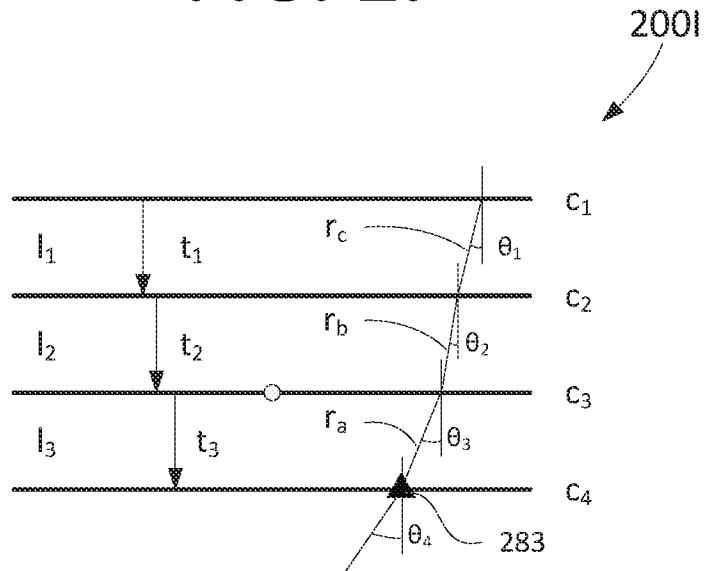

FIG. 2J

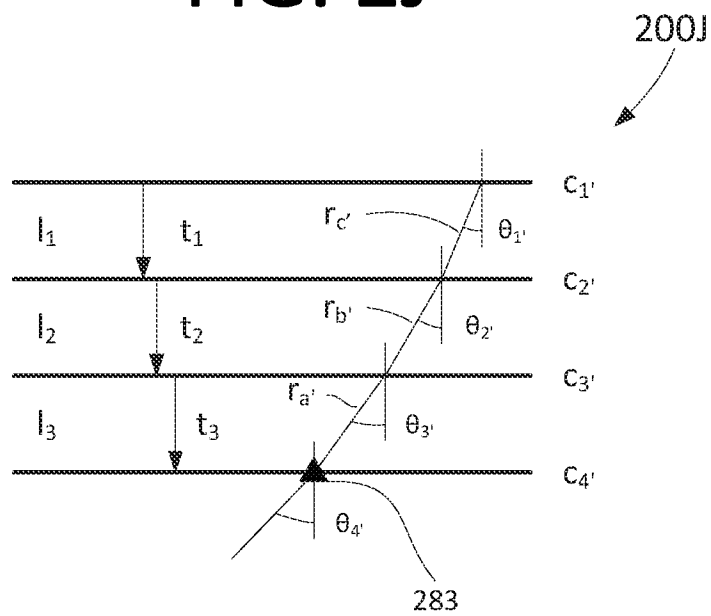

FIG. 3A

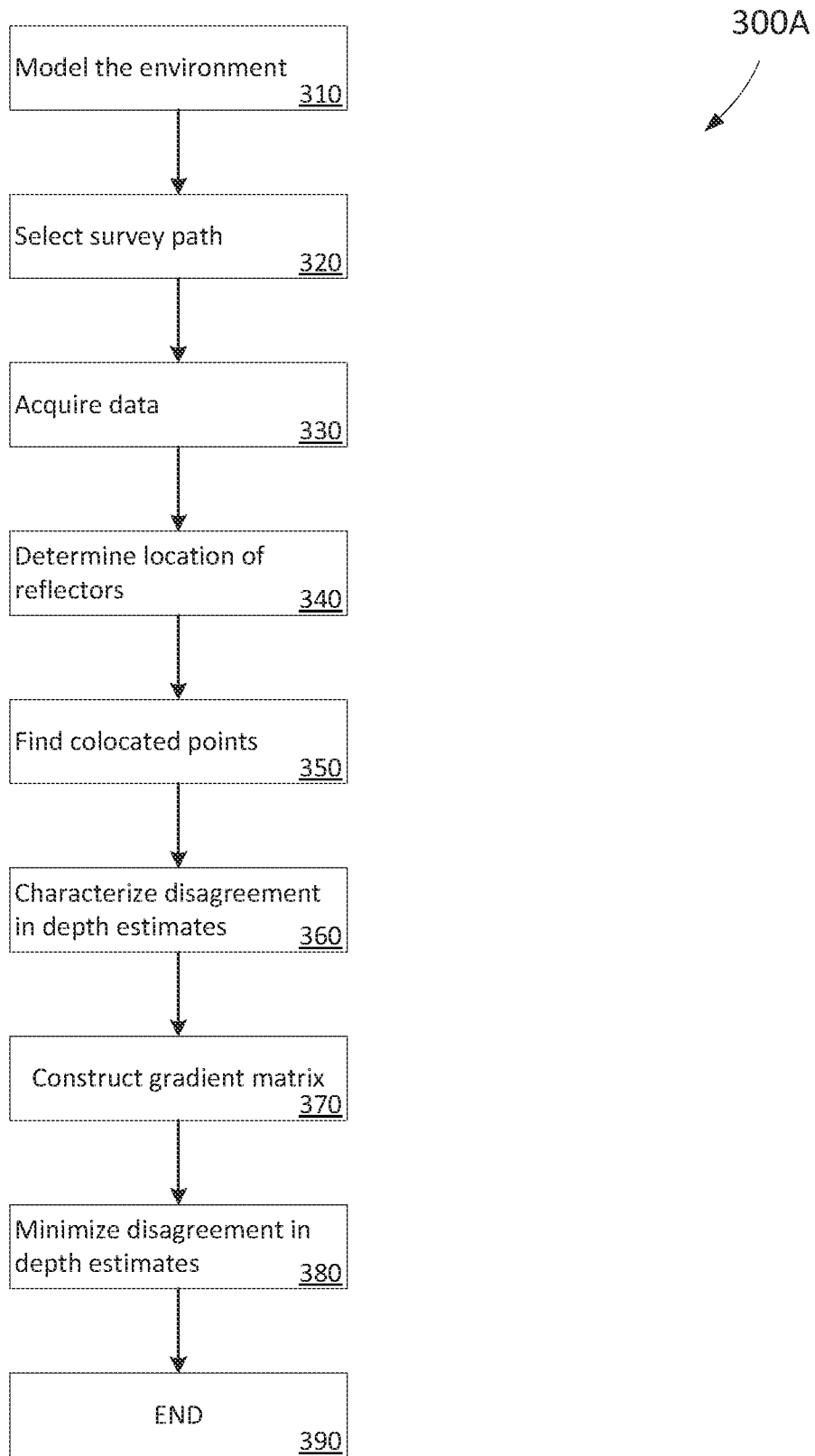
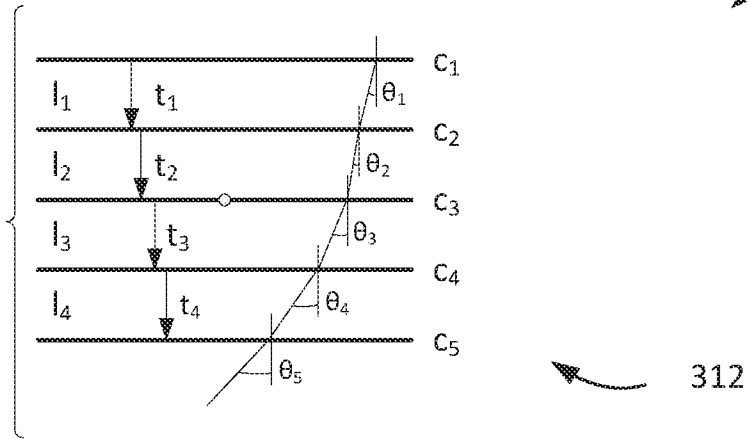

FIG. 3B

Model the environment
310



314

Variable	Description	Known	Defined	Initially Estimated	Unknown
tt	travel time	X			
c_1	launch soundspeed	X			
θ_1	launch angle	X			
t_1	thickness of layer l_1		X		
c_2	soundspeed at l_2 entry			X	
θ_2	angle at l_2 entry			$\theta_2 = f(c_1, c_2, \theta_1)$	
t_2	thickness of layer l_2		X		
c_3	soundspeed at l_3 entry			X	
θ_3	angle at l_3 entry			$\theta_3 = f(c_2, c_3, \theta_2)$	
t_3	thickness of layer l_3		X		
c_4	soundspeed at l_4 entry			X	
θ_4	angle at l_4 entry			$\theta_4 = f(c_3, c_4, \theta_3)$	
t_4	thickness of layer l_4				X
c_5	soundspeed at l_5 entry			X	
θ_5	angle at l_5 entry			$\theta_5 = f(c_4, c_5, \theta_4)$	

f1

FIG. 3C

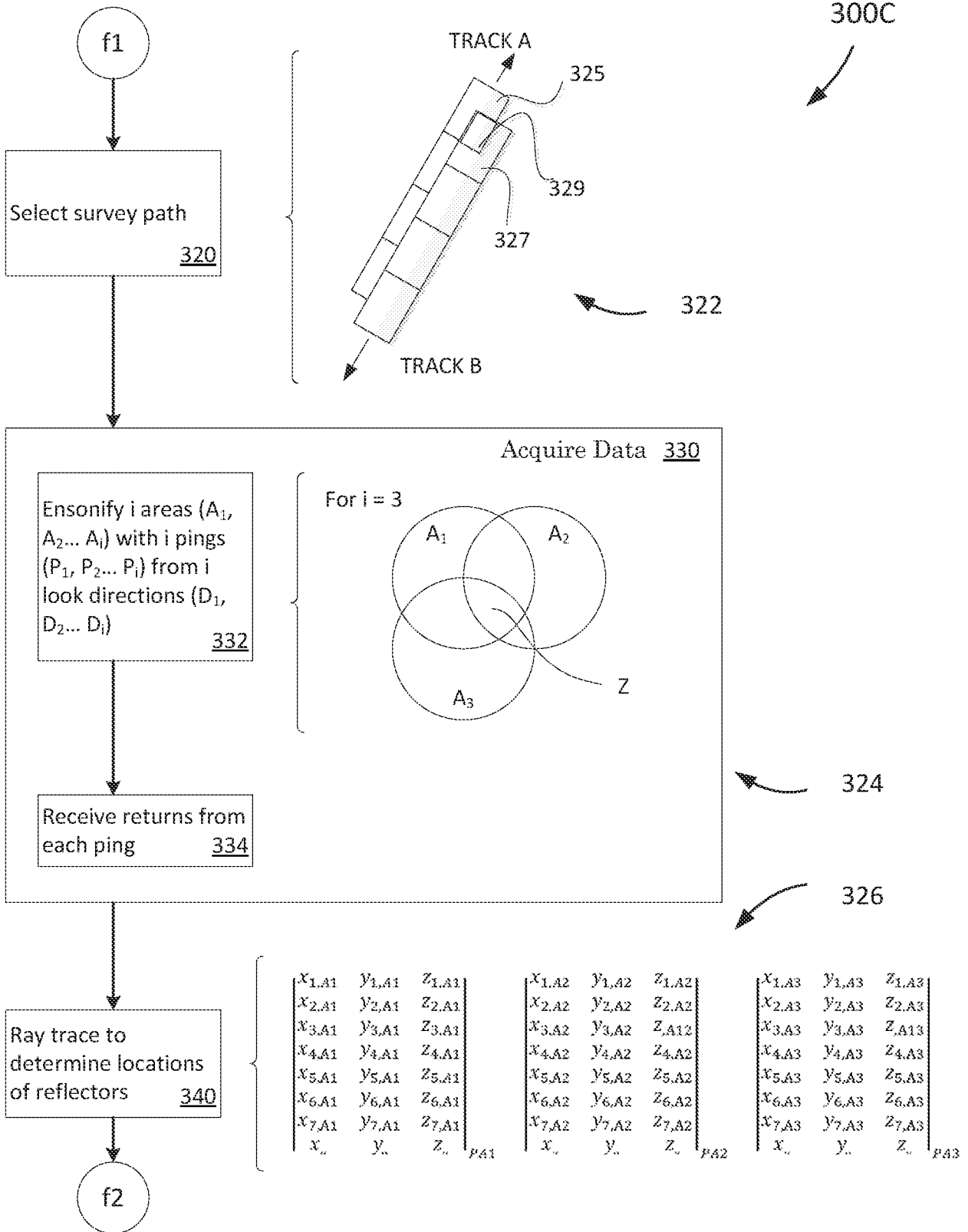

FIG. 3D

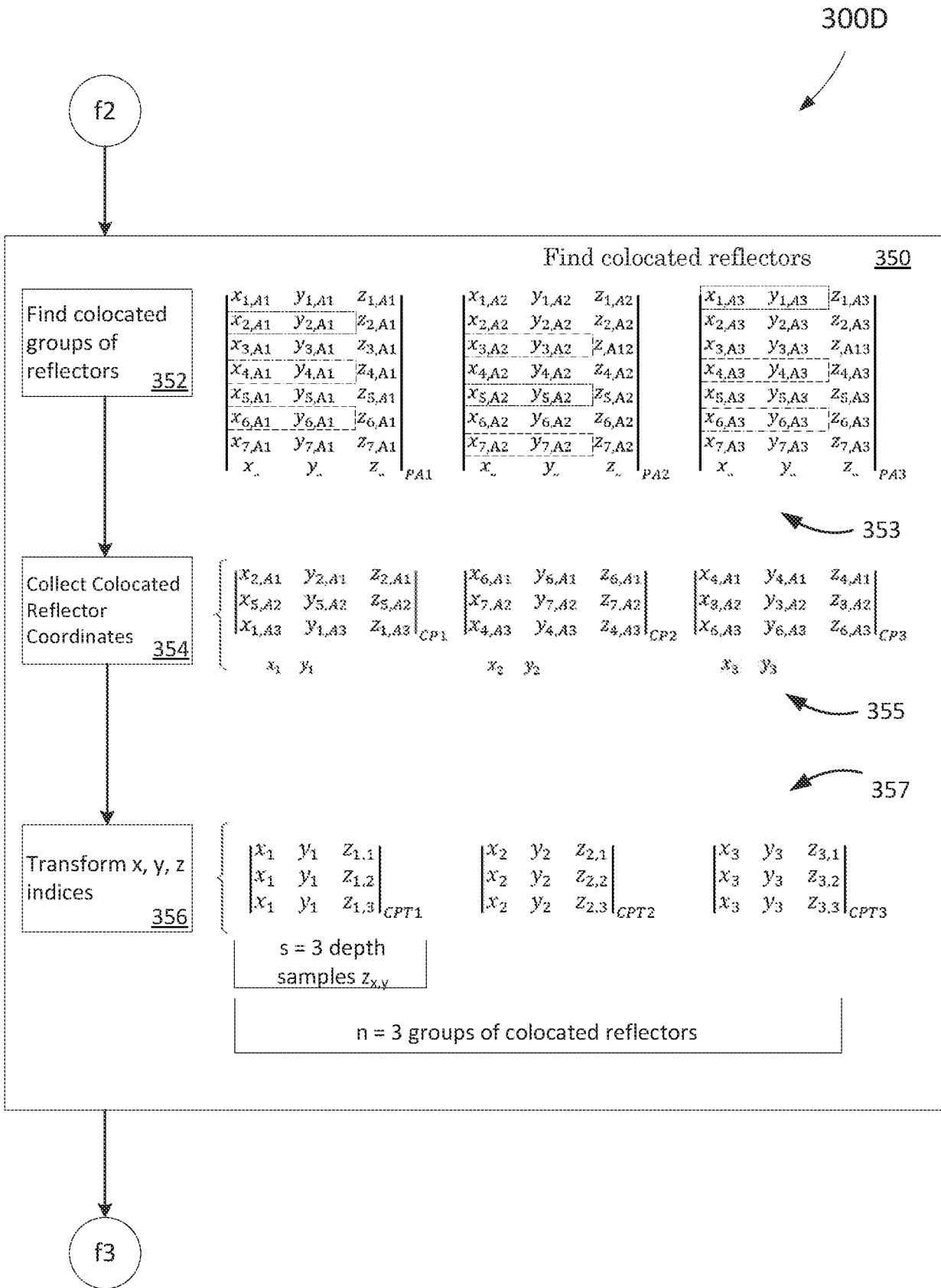

FIG. 3E

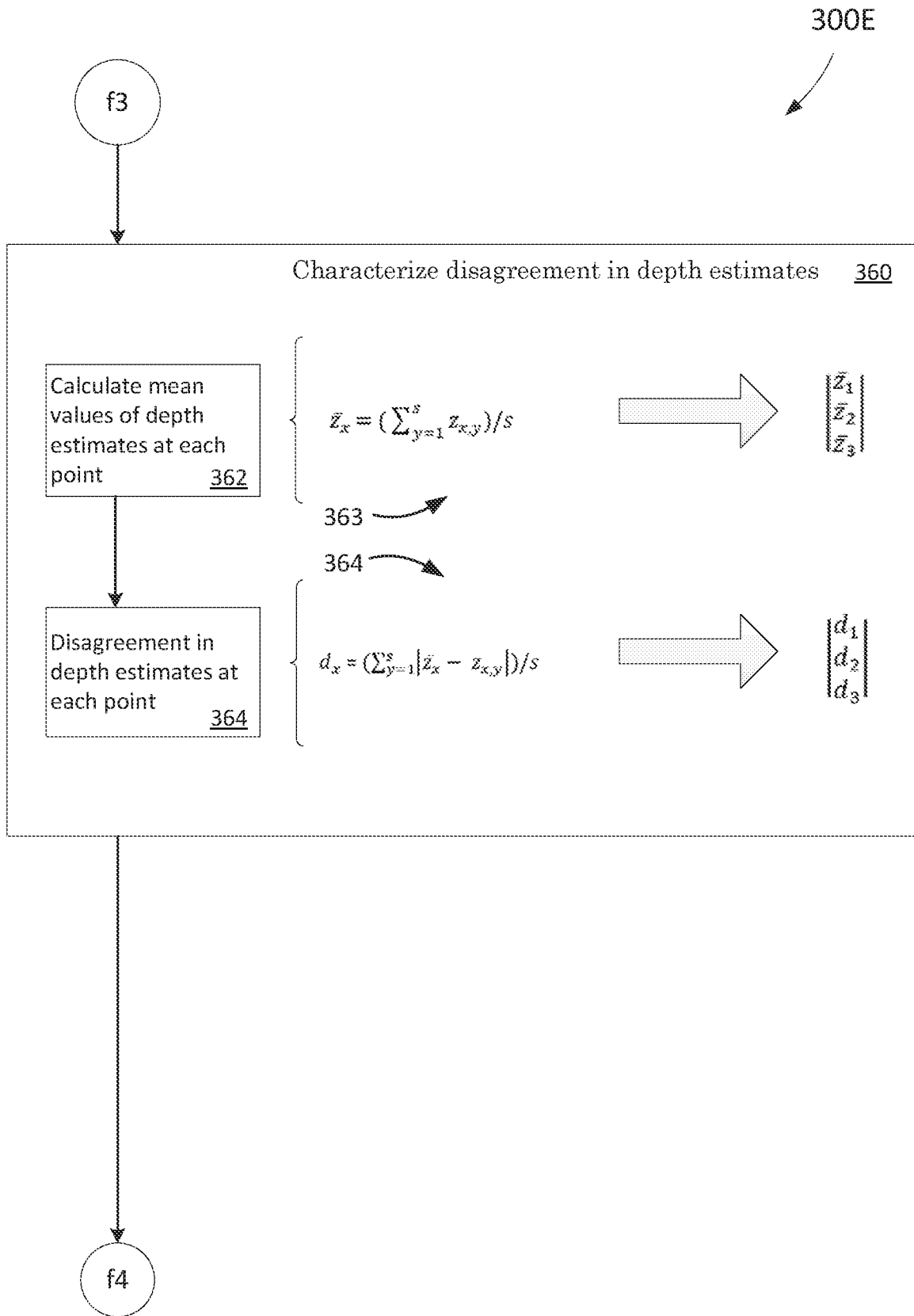

FIG. 3F

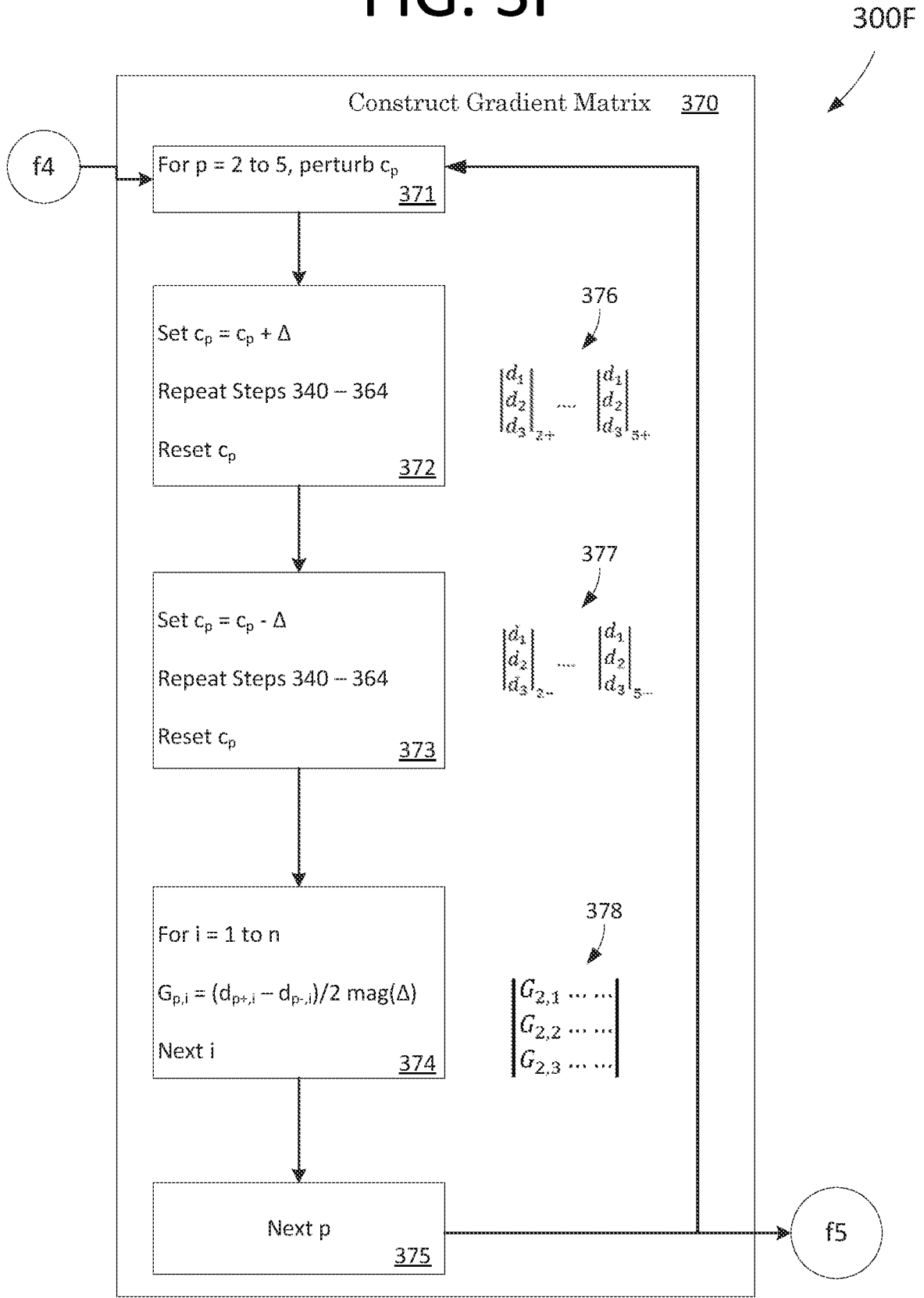

FIG. 3G

300G

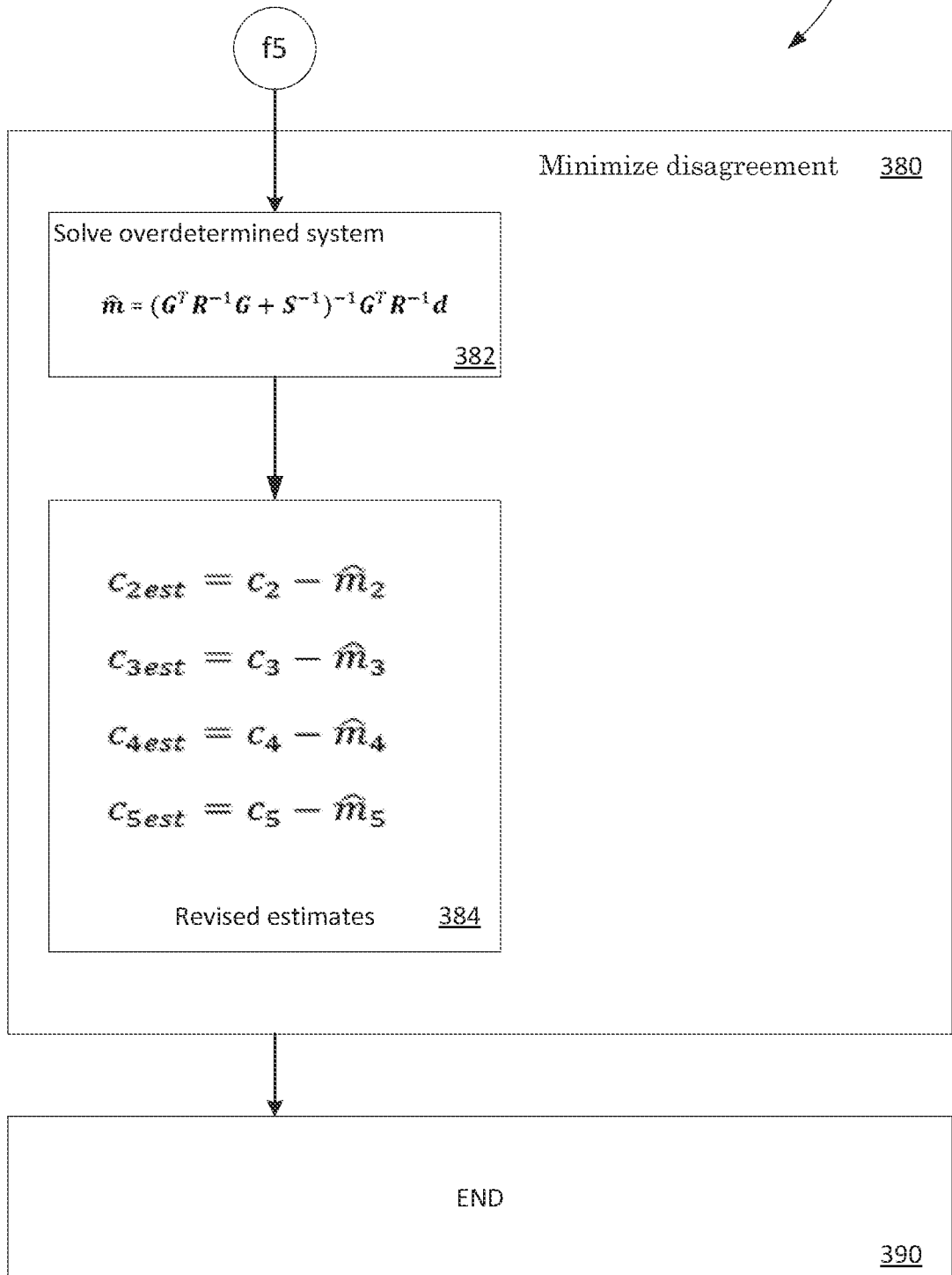
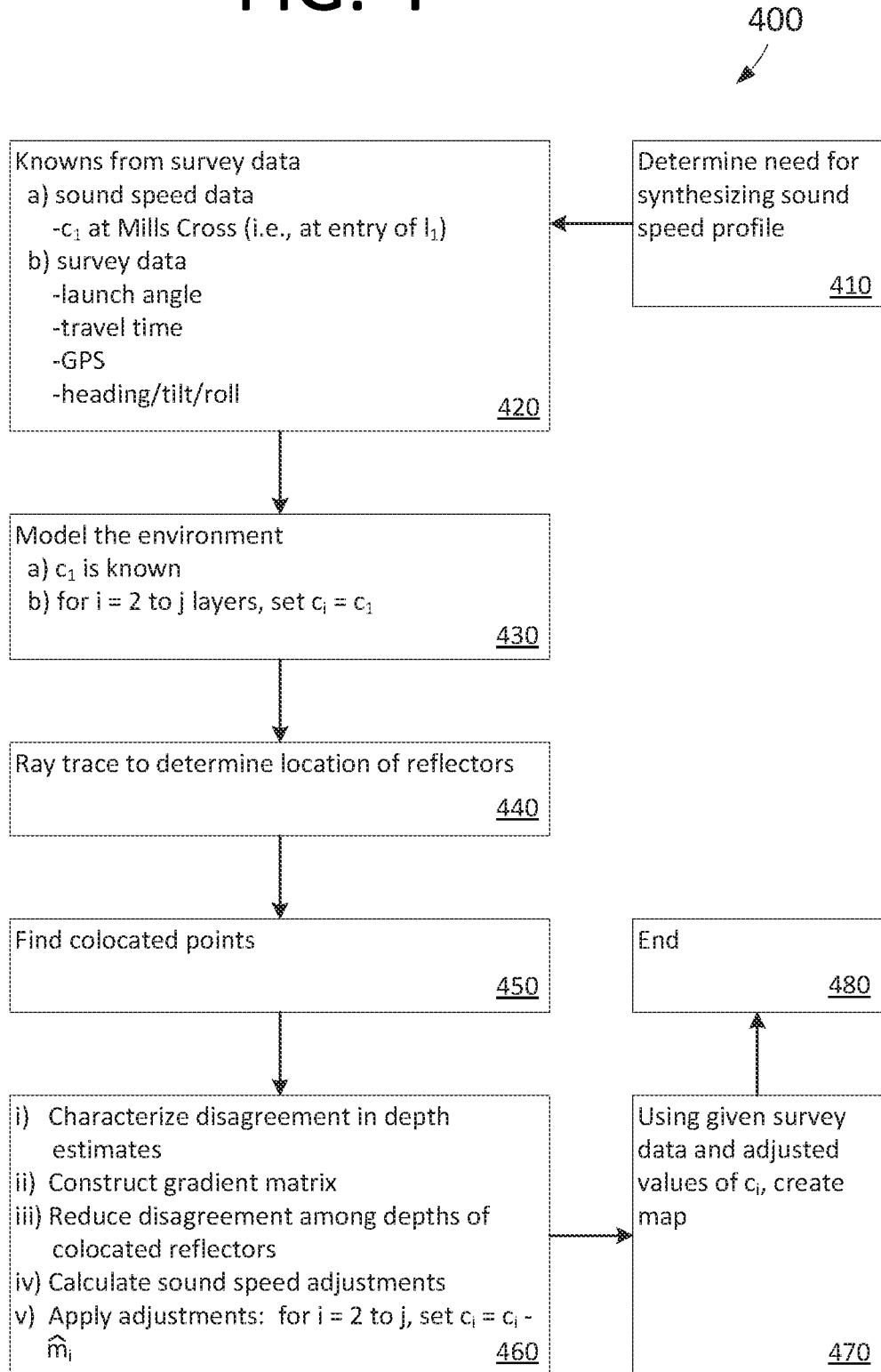

FIG. 4



A. CLASSIFICATION OF SUBJECT MATTER**G01S 15/88(2006.01)i, B63C 11/38(2006.01)i**

According to International Patent Classification (IPC) or to both national classification and IPC

B. FIELDS SEARCHED

Minimum documentation searched (classification system followed by classification symbols)

G01S 15/88; G01S 15/00; G01S 15/89; G01S 15/93; G01S 7/00; G01S 7/52; G01V 1/38; B63C 11/38

Documentation searched other than minimum documentation to the extent that such documents are included in the fields searched

Korean utility models and applications for utility models

Japanese utility models and applications for utility models

Electronic data base consulted during the international search (name of data base and, where practicable, search terms used)

eKOMPASS(KIPO internal) & Keywords: MBES(multibeam echo sounder system), SONAR, modeling, speed

C. DOCUMENTS CONSIDERED TO BE RELEVANT

Category*	Citation of document, with indication, where appropriate, of the relevant passages	Relevant to claim No.
A	US 2008-0137483 A1 (SAWRIE) 12 June 2008 See paragraphs [0002], [0014], [0024], [0034]-[0035]; and figure 1.	1-18
A	US 2012-0327741 A1 (PEARCE) 27 December 2012 See paragraphs [0009]-[0015], [0044], [0066]; and figures 1-4.	1-18
A	US 2016-0011326 A1 (AIRMAR TECHNOLOGY CORPORATION) 14 January 2016 See paragraphs [0005]-[0011], [0102]; and figures 1-3.	1-18
A	US 6438071 B1 (HANSEN et al.) 20 August 2002 See claim 1; and figures 1-3.	1-18
A	US 2007-0025183 A1 (ZIMMERMAN et al.) 01 February 2007 See figures 1-5.	1-18

 Further documents are listed in the continuation of Box C. See patent family annex.

* Special categories of cited documents:

"A" document defining the general state of the art which is not considered to be of particular relevance

"E" earlier application or patent but published on or after the international filing date

"L" document which may throw doubts on priority claim(s) or which is cited to establish the publication date of another citation or other special reason (as specified)

"O" document referring to an oral disclosure, use, exhibition or other means

"P" document published prior to the international filing date but later than the priority date claimed

"T" later document published after the international filing date or priority date and not in conflict with the application but cited to understand the principle or theory underlying the invention

"X" document of particular relevance; the claimed invention cannot be considered novel or cannot be considered to involve an inventive step when the document is taken alone

"Y" document of particular relevance; the claimed invention cannot be considered to involve an inventive step when the document is combined with one or more other such documents, such combination being obvious to a person skilled in the art

"&" document member of the same patent family

Date of the actual completion of the international search

26 October 2018 (26.10.2018)

Date of mailing of the international search report

26 October 2018 (26.10.2018)

Name and mailing address of the ISA/KR

International Application Division

Korean Intellectual Property Office

189 Cheongsa-ro, Seo-gu, Daejeon, 35208, Republic of Korea

Facsimile No. +82-42-481-8578

Authorized officer

KANG, Sung Chul

Telephone No. +82-42-481-8405



INTERNATIONAL SEARCH REPORT

Information on patent family members

International application No.

PCT/US2018/039189

Patent document cited in search report	Publication date	Patent family member(s)	Publication date
US 2008-0137483 A1	12/06/2008	CA 2613525 A1	05/06/2008
		CA 2613528 A1	05/06/2008
		US 2008-151693 A1	26/06/2008
		US 2010-0214874 A1	26/08/2010
		US 7542375 B2	02/06/2009
US 2012-0327741 A1	27/12/2012	GB 2477148 A	27/07/2011
		GB 2477148 B	18/06/2014
		US 9588246 B2	07/03/2017
		WO 2011-089449 A2	28/07/2011
		WO 2011-089449 A3	03/05/2012
US 2016-0011326 A1	14/01/2016	CA 2733895 A1	18/02/2010
		EP 2318860 A1	11/05/2011
		EP 2318860 A4	04/07/2012
		US 2011-0202278 A1	18/08/2011
		US 2016-0216392 A1	28/07/2016
		US 2018-0038977 A1	08/02/2018
		US 9091790 B2	28/07/2015
		US 9772416 B2	26/09/2017
		US 9772417 B2	26/09/2017
WO 2010-017629 A1	18/02/2010		
US 6438071 B1	20/08/2002	AT 480784 T	15/09/2010
		AU 5537599 A	05/01/2000
		AU 760693 B2	22/05/2003
		DK 1097393 T3	08/11/2010
		EP 1097393 A1	09/05/2001
		EP 1097393 B1	08/09/2010
		NO 307014 B1	24/01/2000
		NO 982891 A	20/12/1999
		NO 982891 D0	19/06/1998
		WO 99-66343 A1	23/12/1999
		US 2007-0025183 A1	01/02/2007
EP 2019972 A2	04/02/2009		
EP 2019972 A4	01/12/2010		
US 2003-0235112 A1	25/12/2003		
US 2005-0007880 A1	13/01/2005		
US 2005-0007881 A1	13/01/2005		
US 2005-0099887 A1	12/05/2005		
US 2007-0159922 A1	12/07/2007		
US 7035166 B2	25/04/2006		
US 7123546 B2	17/10/2006		
US 7173879 B2	06/02/2007		
US 7355924 B2	08/04/2008		
WO 03-001231 A2	03/01/2003		
WO 03-001231 A3	18/12/2003		
WO 2005-047930 A1	26/05/2005		

INTERNATIONAL SEARCH REPORT

Information on patent family members

International application No.

PCT/US2018/039189

Patent document cited in search report	Publication date	Patent family member(s)	Publication date
		WO 2007-127271 A2	08/11/2007
		WO 2007-127271 A3	11/12/2008