

(21) Application No: 1308126.0
 (22) Date of Filing: 06.05.2013

(51) INT CL:
 B41J 2/045 (2006.01)

(56) Documents Cited:
 EP 1642718 A2 JP 2005035085 A
 US 20130106933 A1 US 20070070102 A1
 JP H0911457

(71) Applicant(s):
Xaar Technology Limited
 (Incorporated in the United Kingdom)
 Unit 316, Science Park, CAMBRIDGE, CB4 0XR,
 United Kingdom

(58) Field of Search:
 INT CL B41J
 Other: EPODOC WPI

(72) Inventor(s):
Paul Raymond Drury
Jesus Garcia Maza
Mario Massucci
Michael Hook
Anirban Lahiri

(74) Agent and/or Address for Service:
Scott & York Intellectual Property
 45 Grosvenor Road, ST ALBANS, Hertfordshire,
 AL1 3AW, United Kingdom

(54) Title of the Invention: **A printhead actuator circuit**
 Abstract Title: **Printhead actuator circuit**

(57) A printhead actuator circuit 12a is provided which is configured to connect any one of a plurality of waveforms 16a-16n from a signal generator to an output connectable to a printhead actuator 18. The circuit therefore provides much greater flexibility as each printhead actuator 18 of a printhead may be driven by a different waveform 16a-16n. The circuit 12a comprises a signal generator arranged to generate a plurality of waveforms 16a-16n and a plurality of semiconductor switches 23a-23n each associated with one of the plurality of waveforms 16a-16n. The semiconductor switches 23a-23n are configured to selectively connect an associated waveform 16a-16n to the printhead actuator 18. There is also provided a method of controlling a printhead actuator circuit 12a including driving the printhead with a first waveform and subsequently switching to drive the printhead with a second waveform. The first and second waveforms may be out of phase with each other. Successive peaks in the second waveform may increase in amplitude over a predetermined rise time.

Figure 4

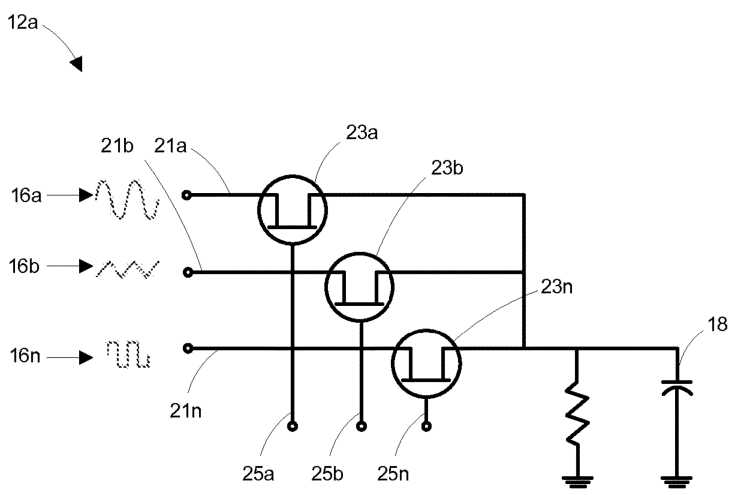

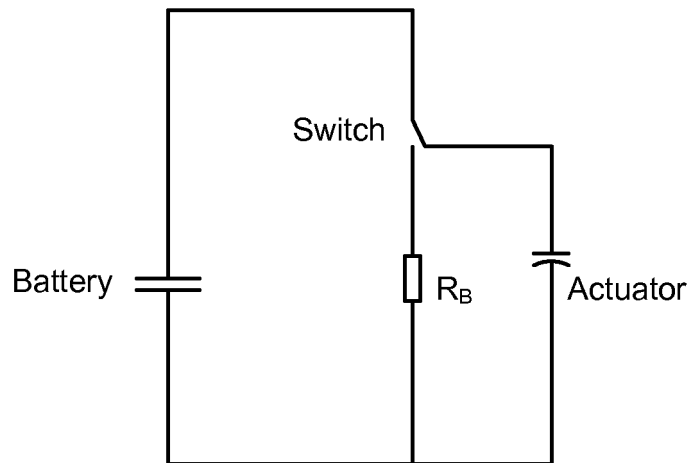

PRIOR ART

Figure 1

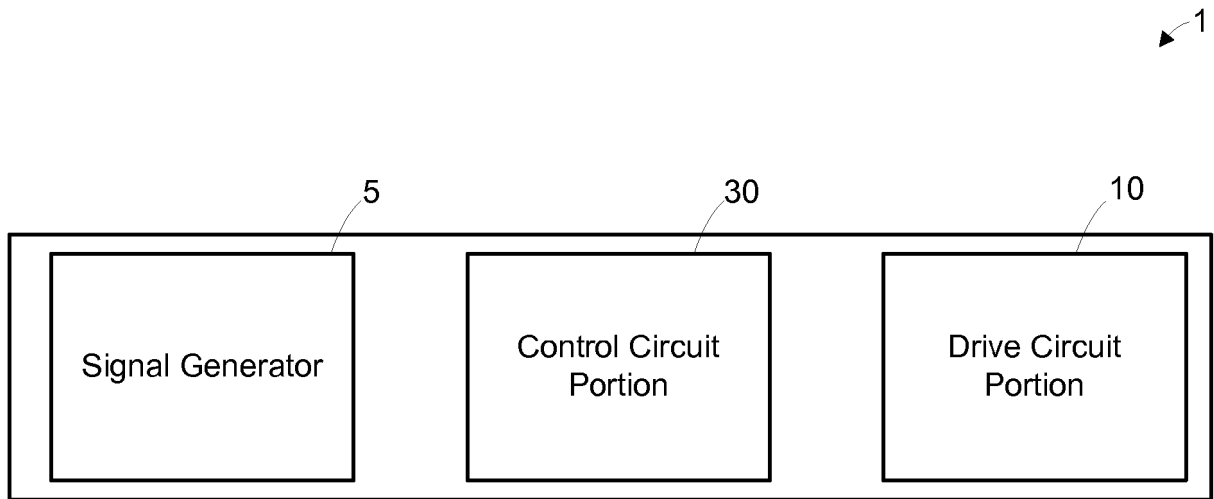

Figure 2

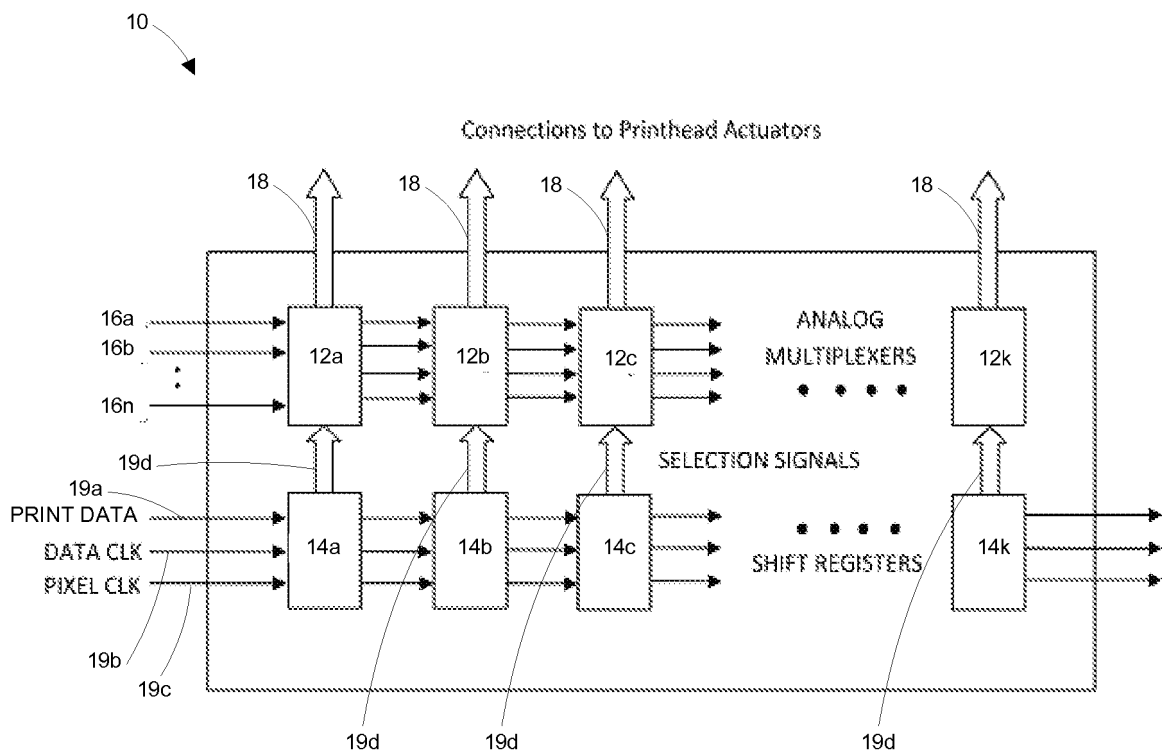

Figure 3

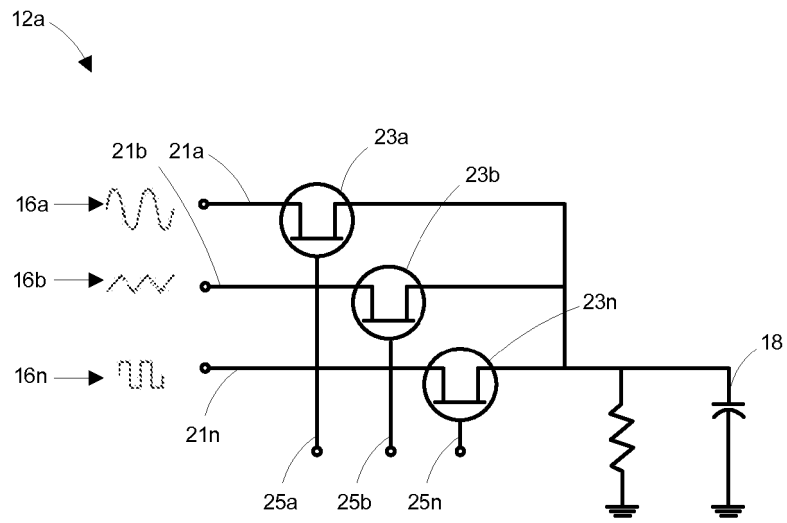

Figure 4

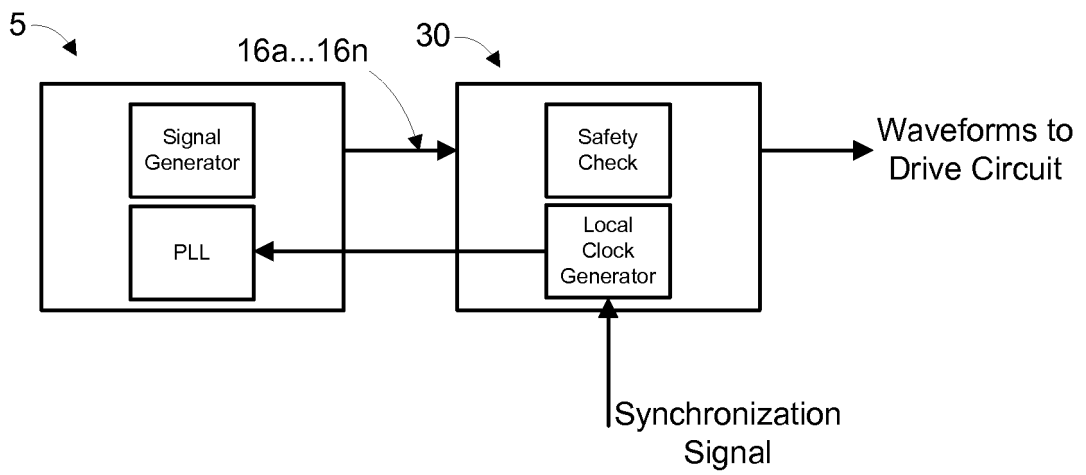

Figure 5

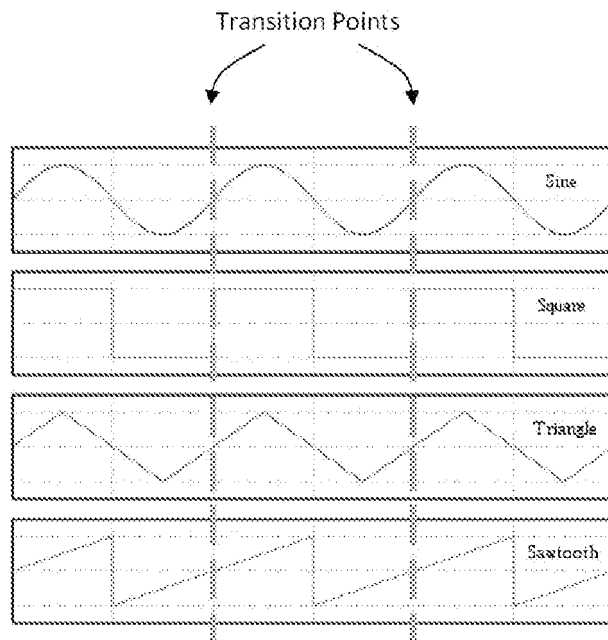

Figure 6

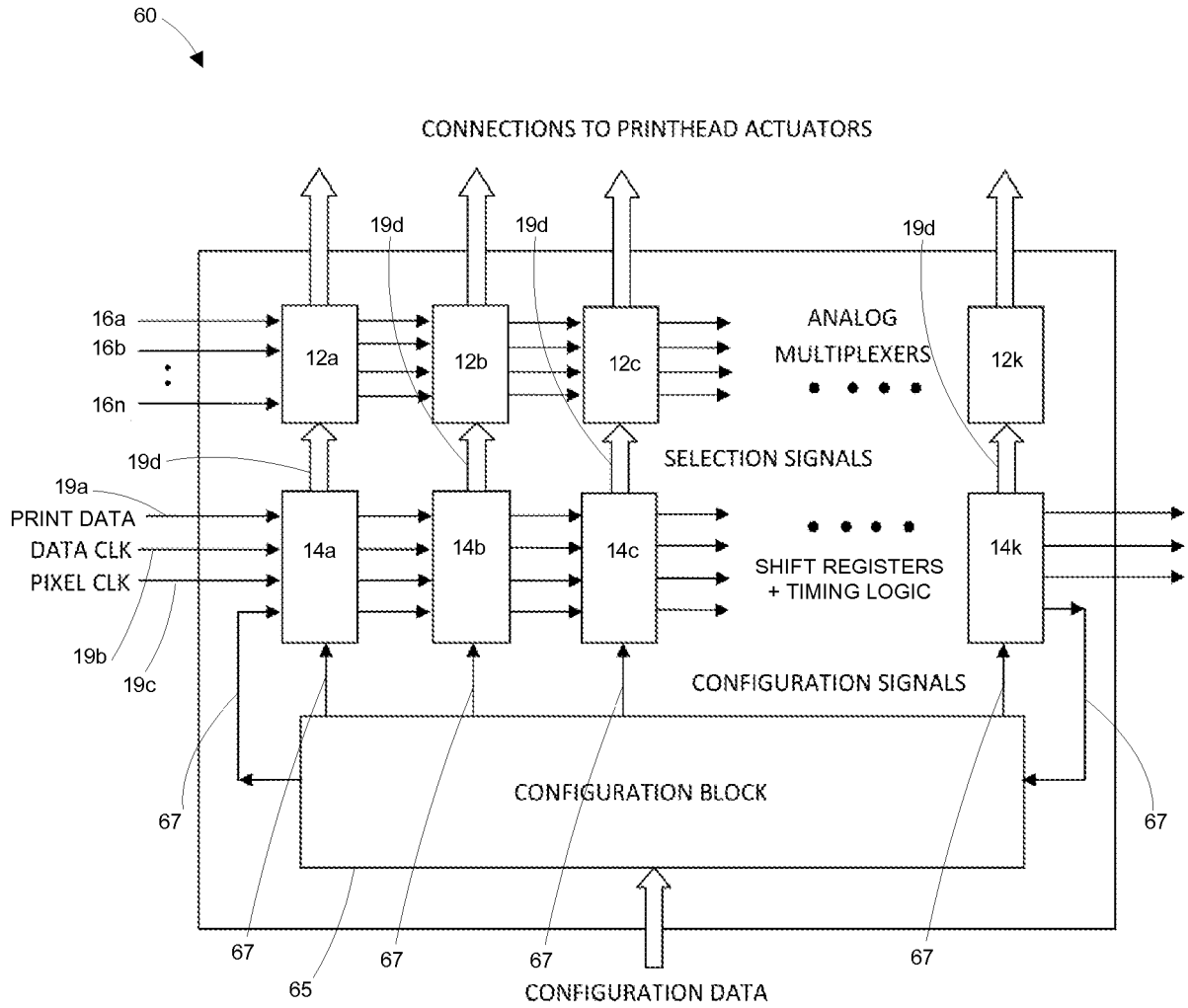

Figure 7

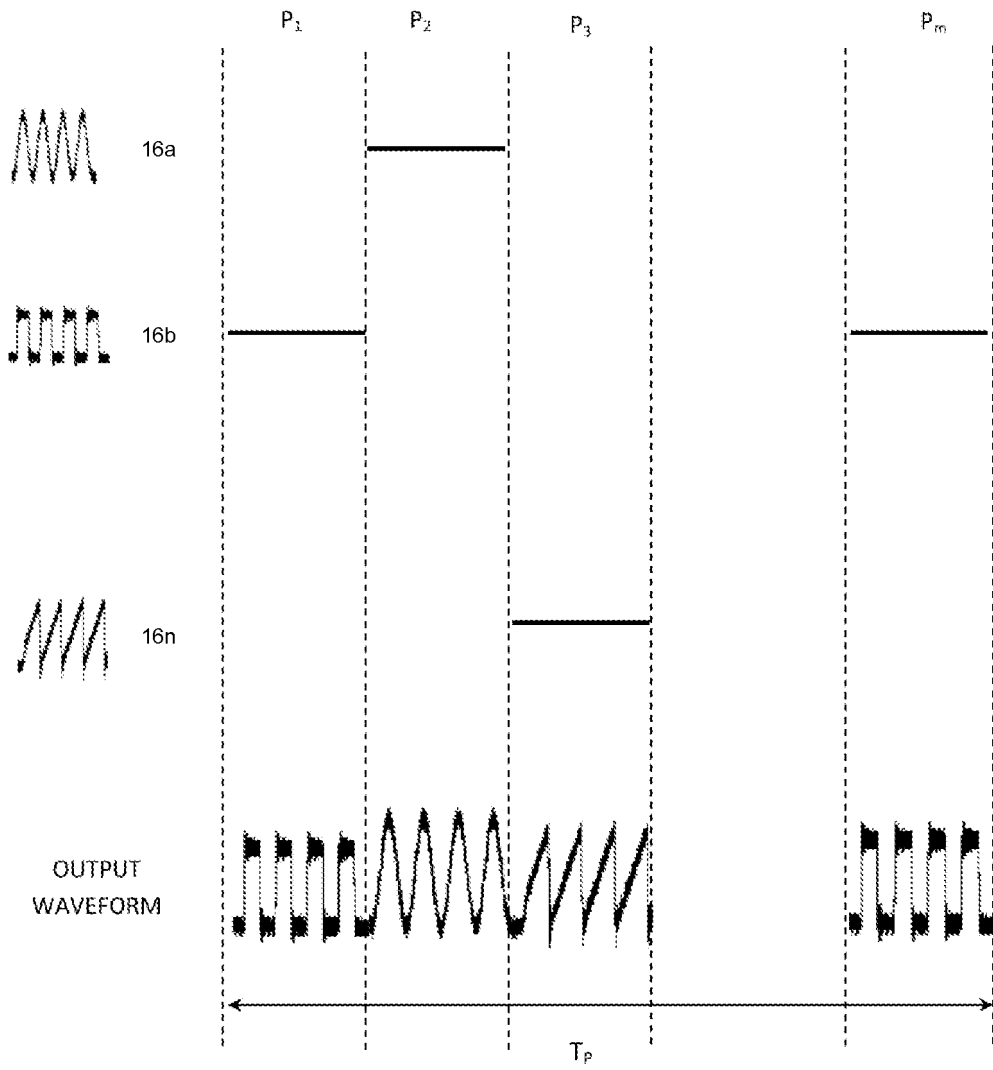

Figure 8a

<u>Greyscale Level</u>	<u>P₁</u>	<u>P₂</u>	<u>....</u>	<u>P_m</u>
<u>D₀</u>	16c	16a		16b
<u>D₁</u>	16b	16a		16c
⋮				
<u>D_{L-1}</u>	16b	16b		16b
<u>D_L</u>	16c	16b		16c

Figure 8b

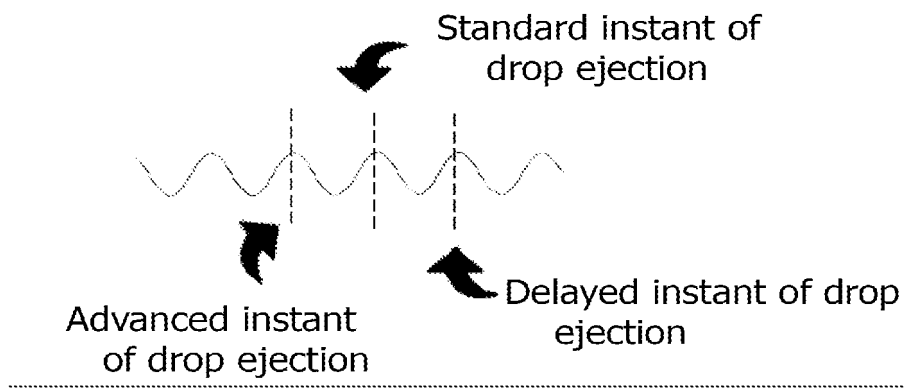

Figure 9

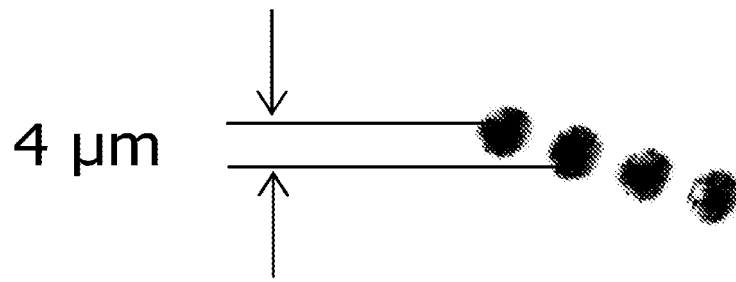

Figure 10

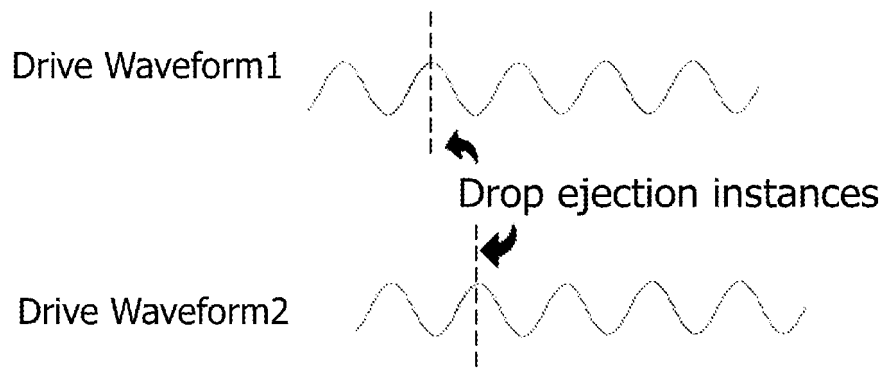

Figure 11

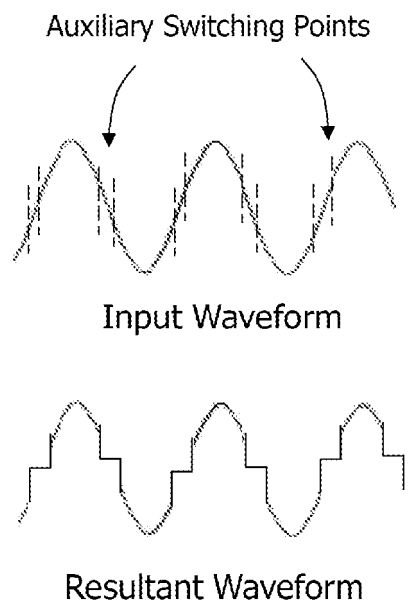

Figure 12

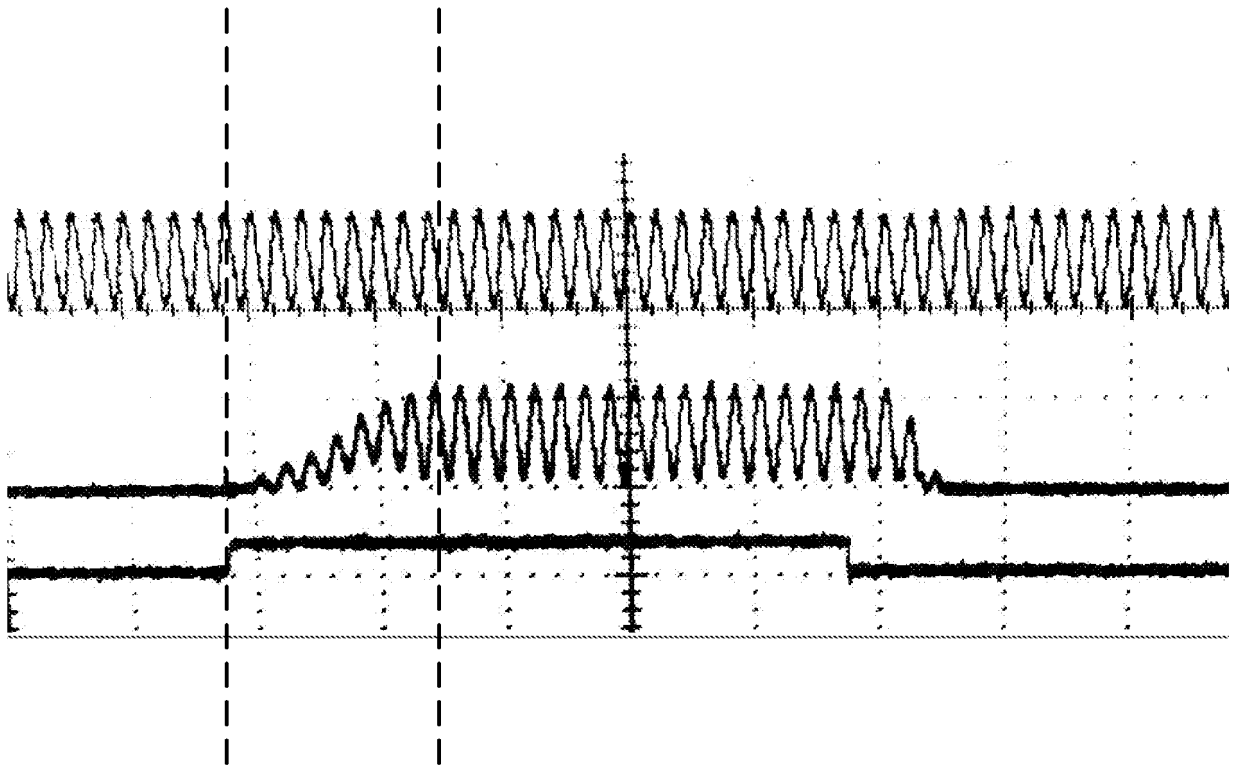

Figure 13

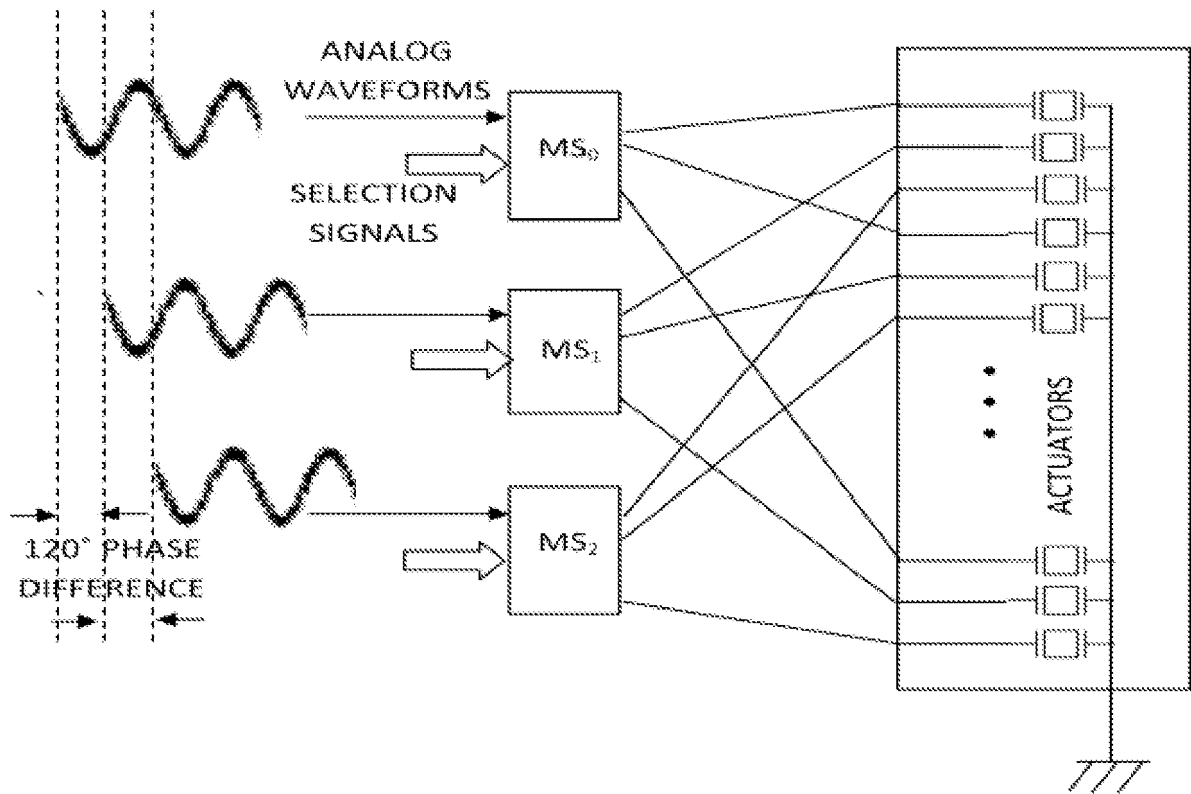

Figure 14

A PRINthead ACTUATOR CIRCUIT

This invention relates to a printhead actuator circuit for a droplet deposition apparatus.

5 Piezoelectric drop on demand inkjet printers include a number of droplet deposition modules, typically known as printheads. These modules include at least one array of fluid chambers each having an aperture through which fluid is ejected as a droplet onto a printing medium. In piezoelectric drop on demand printers, the piezoelectric actuator is the element providing the force for droplet ejection. The piezoelectric actuator is typically in direct communication
10 with the fluid chamber and is driven by a signal from a printhead actuator circuit. As the actuator receives a drive signal, it deforms to cause ejection of a droplet out of the fluid chamber.

The electrical equivalent of a conventional printhead actuator circuit is shown in Figure 1. In
15 the diagram, the piezoelectric actuator is shown as a capacitor as it is primarily a capacitive load. To actuate the piezoelectric element, a switch is moved to a first state and a circuit is formed through the actuator. To discharge the actuator, the switch is moved to a second state such that a circuit is formed through the bleed resistor, R_B . The ohmic heating experienced by the bleed resistor is the main cause of the on-chip thermal footprint on the
20 conventional printhead actuator circuit.

Accordingly, the conventional printhead actuator circuit suffers from thermal issues due to energy dissipation on the chip silicon (which are typically small and therefore have a low surface area to dissipate heat).

The conventional printhead actuator circuit includes a voltage source (in this case, shown schematically as a battery) for driving the printhead actuator, which is typically driven by a square waveform. There is therefore a general lack of flexibility in the way modern printhead actuators are driven.

5

Another conventional printhead actuator circuit is illustrated in United States Patent 7753464. This circuit generates a single drive signal (identified as 'COM') comprising several pulse components, and generates a driving pulse string by selecting pulse components of the single drive signal. The circuit selects particular pulse components based on a driving pulse string for a previous cycle. The technique disclosed in this US patent addresses the issue of an ink droplet being ejected early in the event of residual vibration of the liquid meniscus. However, the circuit is inflexible as it can only be driven by the pulse components of the single drive signal.

10
15 It is therefore desirable to alleviate some or all of the above problems.

According to a first aspect of the invention, there is provided a printhead actuator circuit comprising a signal generator arranged to generate a plurality of waveforms, wherein each waveform is arranged to drive a printhead actuator; a plurality of semiconductor switches, wherein each semiconductor switch is associated with a waveform of the plurality of waveforms; and an output connectable to the printhead actuator, wherein the plurality of semiconductor switches are configured to selectively connect a waveform of the plurality of waveforms to the output.

In the present invention, the printhead actuator circuit includes a plurality of waveforms which may be used to drive the printhead actuator. The driving signal for the printhead actuator may take a variety of different forms, such as sinusoidal, fixed voltage, square, sawtooth, triangular, or any combination thereof. Accordingly, each printhead actuator in the
5 printhead may be driven by a wide variety of different waveforms having different characteristics. This is a significant improvement over the conventional actuator circuits, in which multiple actuators were driven by the same waveform.

The present invention therefore provides a much more flexible driving arrangement for the
10 printhead actuator by providing the plurality of waveforms. For example, the plurality of waveforms may include a first and second waveform which are out of phase with each other. By switching between the first and second waveform, the precise timing of the drop ejection may be modified (e.g. if the waveforms are out of phase by half a wavelength, then the timing of the drop ejection may be modified by half a time period).

15

In another example, a waveform of the plurality of waveforms may be trimmed (i.e. adjusted). As individual printhead actuators are manufactured within various tolerances, the results of a printing process may vary between individual actuators. Accordingly, the driving waveform for a particular printhead actuator may be tailored to suit its particular
20 characteristics. By implementing this technique across all actuators within a printhead, uniform drop ejection and placement may be achieved.

In another example, a waveform of the plurality of waveforms has an operating frequency higher than a switching frequency of the plurality of semiconductor switches. In this
25 example, there is a transition period between switching to the waveform and the output

signal to the printhead actuator reaching a maximum voltage of the waveform. In this transition period, there are several pre-pulses (i.e. pulses that have a smaller amplitude than the waveform) which energize the actuator. This improves the quality of the droplet ejection once the output signal to the printhead actuator reaches a suitable voltage such that a
5 droplet is ejected.

Accordingly, the present invention provides a printhead actuator circuit with much greater flexibility, as the signal for driving the printhead actuator may be switched between a variety of different waveforms having different characteristics. The quality of the printhead (such as
10 accuracy of timing and placement of the droplet ejection) is therefore substantially increased.

Furthermore, the signal generator may include a dissipative element (such as a bleed resistor) which may be located a physical distance away from the printhead actuator. Although the dissipative element is not always necessary, it ensures that its thermal footprint
15 does not have any negative influence on the printing process (such as heating the ink which may change its fluid properties and cause non-uniformity and/or instability in droplet ejection properties).

The printhead actuator circuit may further comprise a register which may be configured to
20 send a selection signal to the plurality of semiconductor switches, wherein the selection signal may cause the plurality of semiconductor switches to connect a predetermined waveform of the plurality of waveforms to the output. In this arrangement, the circuit provides a simple way to control the waveform being selected to drive the printhead actuator. For example, the register may receive a configuration signal including an identifier
25 of the predetermined waveform for a particular printhead actuator. Then, the selection signal

may cause the plurality of semiconductor switches to connect that waveform to the output for driving the printhead actuator. The selection signal may be sent to the plurality of semiconductor switches on every rising edge of a pixel clock (i.e. on every instance of ink ejection).

5

The selection signal may cause the plurality of semiconductor switches to connect a predetermined subset of waveforms of the plurality of waveforms to the first output. Thus, a combination of waveforms may be used to drive the printhead actuator.

10 The configuration signal may be updated at a first clock rate (e.g. the data clock), and the selection signal may be sent to the plurality of semiconductor switches at a second clock rate (e.g. the pixel clock).

The plurality of waveforms may be synchronized such that each waveform of the plurality of waveforms may have substantially the same voltage at a transition point, the transition point being when the plurality of semiconductor switches receives the selection signal. With this arrangement, there is no significant discontinuity (a significant step change) in voltage when the plurality of semiconductor switches switch between waveforms (which would otherwise damage the printhead actuator). The voltage of each waveform of the plurality of waveforms at the transition point may have a predetermined non-zero value, and or may be chosen to be substantially 0V.

The register may be a shift register, and the plurality of semiconductor switches may be arranged as a multiplexer. The multiplexer may be one of a plurality of multiplexers and the output may be one of a plurality of outputs (connectable to a respective printhead actuator),

25

wherein each multiplexer may be configured to selectively connect a waveform of the plurality of waveforms to the output. The present invention is therefore scalable to drive a plurality of printhead actuators (such as an array of actuators on a printhead) using the plurality of waveforms, wherein each actuator in the plurality of printhead actuators may be
5 driven by any one (or any combination) of the plurality of waveforms. Accordingly, each actuator may have a tailored waveform which increases the overall drop placement and drop volume accuracy of the printhead. Drop placement is for example affected by drop velocity angular deviation and drop ejection timing.

10 The printhead actuator circuit may further comprise a plurality of registers, wherein each register may be configured to send a selection signal to an associated multiplexer of the plurality of multiplexers, the selection signal causing the associated multiplexer to connect a predetermined waveform of the plurality of waveforms to the respective output. The register provides a simple and easy to update mechanism to control the switching of the plurality of
15 multiplexers.

According to a second aspect of the invention, there is provided a method of controlling a printhead actuator circuit, the printhead actuator circuit configured to selectively connect one of a plurality of waveforms to a printhead actuator, the method comprising the steps of:
20 driving the printhead actuator with a first waveform of the plurality of waveforms, and switching to a second waveform of the plurality of waveforms, such that the printhead actuator is driven by the second waveform, wherein the first and second waveform are out of phase with each other.

The first and/or second waveform may be trimmed to produce a tailored waveform. For example, the input waveform may be switched on and off such that the output waveform differs from the input waveform in amplitude and/or waveform shape.

- 5 According to a third aspect of the invention, there is provided a method of controlling a printhead actuator circuit, the printhead actuator circuit configured to selectively connect one of a plurality of waveforms to a printhead actuator, the method comprising the steps of: driving the printhead actuator with a first waveform of the plurality of waveforms, and switching to a second waveform of the plurality of waveforms, such that the printhead
10 actuator is driven by the second waveform, wherein successive peaks in the second waveform increase in amplitude over a predetermined rise time.

Embodiments of the invention will now be described, by way of example, and with reference to the drawings in which:

15

Figure 1 is circuit diagram of a conventional printhead actuator circuit;

Figure 2 is a schematic diagram of a first embodiment of a printhead actuator circuit of the present invention;

Figure 3 is a schematic diagram of a drive circuit portion of the circuit of Figure 2;

20 Figure 4 is a circuit diagram of a multiplexer of the drive circuit portion of Figure 3;

Figure 5 is a schematic diagram of a control circuit portion of the circuit of Figure 2;

Figure 6 illustrates various waveforms and transition points;

Figure 7 is a schematic diagram of a second embodiment of a printhead actuator of the present invention;

25 Figure 8a illustrates a waveform output over several time epochs;

Figure 8b illustrates a waveform configuration table;

Figure 9 illustrates a first technique of nozzle trimming;

Figure 10 illustrates drop placement accuracy using the first technique of Figure 9;

Figure 11 illustrates a second technique of nozzle trimming;

5 Figure 12 illustrates a third technique of nozzle trimming;

Figure 13 illustrates a fourth technique of nozzle trimming; and

Figure 14 illustrates a fifth technique of nozzle trimming.

A first embodiment of a printhead actuator circuit 1 will now be described. Figure 2
10 illustrates a schematic overview of the circuit 1, including a signal generator 5, a control
circuit portion 30, and a drive circuit portion 10. The drive circuit portion 10 will now be
described in more detail.

As shown in Figure 3, the drive circuit portion 10 includes a plurality of multiplexers
15 12a...12k and a plurality of shift registers 14a...14k. Each multiplexer of the plurality of
multiplexers 12a...12k is configured to receive a plurality of waveforms 16a...16n from the
signal generator 5 and includes an output 18 for connection to a respective printhead
actuator. The multiplexers are configured to connect any one of the plurality of waveforms
16a...16n to the output 18 upon receiving a selection signal 19d from a respective shift
20 register including a corresponding identifier for that waveform.

The plurality of shift registers 14a...14k are configured to receive a print data signal 19a, a
data clock 19b, and a pixel clock 19c from a data controller. In this embodiment, the print
data signal 19a is sequentially shifted in to the plurality of shift registers 14a...14n, and the
25 rate of shifting of the print data 19a is synchronised with the data clock 19b.

The shift registers 14a...14n are configured for sending the print data 19a to each respective multiplexer in the form of a selection signal 19d. The rate of sending the selection signals 19d to the multiplexers is synchronised with the pixel clock 19c such that each selection
5 signal is sent on the rising edge of the pixel clock 19c. The pixel clock corresponds to the rate of ejection of ink droplets from the printhead. The selection signal 19d defines which waveform of the plurality of waveforms 16a...16k the multiplexer should connect to the output 18 and therefore drive the printhead actuator. The print data 19a and the selection
10 signal 19d therefore include an identifier for the waveform of the plurality of waveforms to be used to drive the printhead actuator.

The skilled person will therefore realise that the print data 19a is sequentially shifted in to the plurality of shift registers 14a...14n at the rate of the data clock. The corresponding multiplexer then selects the desired waveform for its associated printhead actuator at the
15 rate of the pixel clock, and the printhead actuator is subsequently driven with the desired waveform.

Each printhead actuator may therefore be driven by a different waveform of the plurality of waveforms 16a...16n by simply configuring the shift registers 14a...14k such that they send
20 selection signals 19d with the appropriate identifiers to the corresponding multiplexer. The shift registers 14a...14k may be updated by shifting in the print data (as shown in Figure 1), or alternatively by a configuration block (as described in the second embodiment, below). The printhead actuator circuit 1 therefore provides a simple, scalable and more flexible way of controlling the printhead actuators.

As noted above, the plurality of multiplexers 12a...12k are configured to connect one of the plurality of waveforms to the printhead actuator (the other waveforms are kept as open circuits such that there is no flow of current on these channels). Though this is not necessary, the signal generator in this embodiment may include a dissipative element (such as a bleed resistor), such that any dissipated energy is expelled a physical distance away from the drive circuit portion 10. Accordingly, the on-chip thermal footprint of the printhead actuator circuit 1 is less than the conventional printhead actuator circuits of the prior art.

An example multiplexer 12a of the plurality of multiplexers 12a...12k will now be described in more detail with reference to Figure 4. The multiplexer 12a includes a plurality of input lines 21a...21n each configured to receive one of a plurality of waveforms 16a...16n, and an output 18 for connection to a printhead actuator. Each input line 21a...21n includes a semiconductor switch 23a...23n (which, in this embodiment, are constructed from FETs). In a first (active) state, the plurality of semiconductor switches 23a...23n are configured to connect the waveform received on that input line to the output 18 and thus to the printhead actuator. In a second (inactive) state, the plurality of semiconductor switches 23a...23n do not connect the waveform received on that input line to the output 18.

The semiconductor switches 23a...23n are each connected to a set of selection lines 25a...25n, which are configured to receive the selection signal 19d from the associated shift register 14a...14k. The selection signal 19d received on the selection line 25a...25n determines which semiconductor switch of the plurality of semiconductor switches 23a...23n should be in the active state, such that the waveform received on the input line for that semiconductor switch connects to the output 18 (whereas all the other semiconductor

switches of the plurality of semiconductor switches 23a...23n do not connect their respective waveforms to the output 18).

The skilled person will understand that the multiplexer 20 is therefore scalable to a plurality
5 of multiplexers, each having an output connectable to a respective printhead actuator, and
each configured to receive a selection signal 19d from an associated shift register 14a...14n
to connect one of the plurality of waveforms to the respective printhead actuator. The
plurality of multiplexers 12a...12k are configured such that the plurality of waveforms
16a...16n pass through sequentially (rather than each multiplexer being connected to the
10 signal generator 5).

A control circuit portion 30 of the printhead actuator circuit 1 will now be described in more
detail with reference to Figures 5 and 6. The control circuit 30 receives a plurality of
waveforms 16a...16n from the signal generator 5. The control circuit 30 allows a waveform
15 of the plurality of waveforms 16a...16n to pass through it to the drive circuit portion 10 if the
synchronization is correct. The synchronization is correct if at a particular transition point,
as shown in Figure 6, the voltage of each waveform is of a predetermined and substantially
the same value. This value may be a non-zero value, or may be chosen to be substantially
0V. If a waveform of the plurality of waveforms does not have the correct synchronization,
20 the control circuit portion 30 prevents it from being propagated to the drive circuit portion 10.

The control circuit portion 30 includes a local clock generator 21 and the signal generator 5
includes a phase locked loop 7 to enforce the correct synchronization amongst the plurality
of waveforms 16a...16n.

In this embodiment, the signal generator 10 is responsible for generating charge and for accommodating the discharge of the capacitive loads through it.

The synchronization will now be described in more detail with reference to Figures 3 and 6.

5 The pixel clock 19c (i.e. the rate of ink ejection and thus the rate at which the print data 19a is sent to the multiplexers as a selection signal 19d and the rate at which the actuators are driven by the selected waveform) may, for example, have a square waveform. As noted above, the print data 19a is sent to the plurality of multiplexers 12a...12k on the rising edge of the pixel clock 19a, and thus the rising edge of the square waveform.

10

The selection signal 19d defines which waveform (e.g. sinusoidal, square, triangle, sawtooth, or any combination of the same as described below) to forward to the output of the multiplexer and therefore to the corresponding printhead actuator. The selection signal 19d therefore causes the respective multiplexer to switch between waveforms at the transition point at the rising edge of the pixel clock. As the control circuit portions has verified that 15 each waveform is synchronized, such that each waveform of the plurality of waveforms 16a...16n has substantially the same voltage at the transition point, there is no substantial discontinuity in voltage when the multiplexer switches to a different waveform. As the waveform is instantaneously forwarded to the output of the multiplexer and therefore to the 20 printhead actuator, there is therefore no sudden step change in the voltage of the output signal (which would otherwise damage the sensitive actuator).

As noted above, the selection signal 19d defines which waveform to forward to the output of the multiplexer to drive the printhead actuator. This may simply be any one of the plurality of 25 waveforms, but may also be a combination of the waveforms. Accordingly, the flexibility of

the printhead actuator circuit is increased as the user may drive the printhead actuators with a variety of different waveforms.

A second embodiment of a printhead actuator circuit will now be described with reference to
5 Figure 7. Again, the printhead actuator circuit 50 of the second embodiment includes a drive circuit portion 60 (and like for like reference numerals have been used). However, in this embodiment, the drive circuit portion 60 includes a configuration block 65.

The configuration block 65 is configured to send a configuration signal 67 to the plurality of
10 shift registers 14a...14k. The configuration signal 67 defines which waveform of the plurality of waveforms 16a...16k should be selected by each multiplexer and therefore configures each corresponding shift register 14a...14k to control the multiplexers accordingly (such as by sending the selection signal on the appropriate line). Thus, on each rising edge of the pixel clock 19a, a selection signal 19d is sent to each multiplexer and the multiplexer
15 switches to the corresponding waveform.

In this embodiment, the configuration data determines the waveform required for a particular drop volume. This information is stored in a configuration (look-up) table, and the print data 19a indicates whether or not a drop is required at a particular position on the medium and its
20 volume.

The configuration information may therefore be loaded in advance by a configuration data signal to the configuration block 65. This configuration information can be stored in the form of a look-up table either for all actuators being addressed, a subset of actuators or an
25 individual actuator. An example waveform configuration and corresponding waveform

configuration table are shown in Figures 8a and 8b respectively, in which P_m refers to a particular time epoch and D_j refers to a particular greyscale level. The sequence of transitions between the waveforms over the time epochs for any particular greyscale level may thus be determined from the configuration table.

5

Thus, in this embodiment, the waveform composition needed for a particular drop volume composed of a particular number of droplets is known in advance, and this information is saved in the configuration table. The print data 19a is then used only to specify the volume of a required drop.

10

The drive circuit portion 10, 60 may be extended to multiple electrodes for each actuator by including a subset of multiplexers and shift registers from the plurality of multiplexers 12a...16k and plurality of shift registers 14a...14k for the multiple electrodes. This also allows for nozzle trimming (i.e. adjustments in the waveform voltages to enhance the efficiency of the actuator with respect of nozzle ejection and drop placement accuracy).
15 Some examples of nozzle trimming will now be described in more detail with reference to Figures 9 to 12.

Figure 9 illustrates a sinusoidal waveform of the plurality of waveforms 16a...16n. The
20 sinusoidal waveform includes a plurality of pulselets (i.e. peaks) marked with vertical dotted lines. The dotted lines indicate an instance of drop ejection (which occurs after the transition point which is at or close to zero voltage), and Figure 9 shows a standard instance, a delayed instance (i.e. at a point on the waveform that occurs at a time period after the standard instance), and an advanced instance (i.e. at a point on the waveform that occurs at

a time period before the standard instance). The timing of the drop ejection may be altered by ejecting the drop either at the delayed or advanced pulselet on the waveform.

In one example of the above technique, a printer has a print speed of 2 metres per second
5 and a 250kHz drive waveform frequency. As shown in Figure 10, the drop placement error due to misalignment can be corrected to an accuracy of $4\mu\text{m}$ by ejecting the drop at either the advanced or delayed pulselet.

The skilled person will understand that the drive circuit portion 10, 60 may be adapted to
10 drive the actuator with a particular pulselet by adapting the pixel clock 19c and the timing logic in the shift registers 14a...14k. That is, the pixel clock 19c rate may be altered such that a multiplexer selects a particular waveform at a transition point before the advanced or delayed pulselet, such that the ink drop is ejected at the next peak.

15 In a second technique, the accuracy of drop placement may be further improved (as shown in Figure 11). In this technique, the plurality of waveforms includes two waveforms which are out-of-phase with each other. In this example, the two waveforms are sinusoidal and have a frequency of 500kHz and are out of phase by 180 degrees. The skilled person will understand that although the waveforms in this technique are out of phase with each other,
20 they still have a transition point at or near zero voltage.

In this example, the drop placement accuracy may be increased by $2\mu\text{m}$ by switching the multiplexer to the second waveform at the transition point, such that the drop ejection instance occurs at the next peak

A third technique may be used in conjunction with the first and second techniques outlined above. In the example shown in Figure 12, the sinusoidal waveform supplied by the control circuit portion 30 is trimmed by the drive circuit at auxiliary switching points to produce a tailored waveform (shown as "resultant waveform in Figure 12). This technique allows for tailoring a generic waveform to suit the characteristics of individual actuators/nozzles/channels so as to obtain uniform drop ejection and placement from all actuators/nozzles/channels in the printhead. Accordingly, this technique may optimize drop position and drop volume by accounting for manufacturing variances between the individual actuators/channels/nozzles in the printhead.

10

A fourth technique will now be described with reference to Figure 13. In this technique, a waveform of the plurality of waveforms 16a...16n is depicted as the top waveform in the figure, the square waveform represents the state of a gate controlling a multiplexer of the plurality of multiplexers 12a...12k, and the resultant output signal is represented as the middle waveform in the figure.

15

In this technique, the multiplexer receives a selection signal to switch between different waveforms, and a switch 'ON' signal which determines whether the selected waveform is propagated to the output. When the switch 'ON' signal is active, the output signal gradually takes the sinusoidal form of the waveform provided at the input and gradually increases in amplitude over a predetermined rise time. This rise time is defined by the switching characteristics of the semiconductor switch. The characteristics of the semiconductor switch and the switch 'ON' signal may be adjusted to produce tailored waveforms having particular rise times.

25

The output signal in this technique therefore includes a set of pre-pulses which energizes the actuator channel such that it becomes ready for jetting, but does not cause a droplet to be ejected. At the end of the rise time, the output of the multiplexer is at the desired amplitude for the waveform and droplets are ejected from the now energized actuator channel.

5

A fifth technique will now be described with reference to Figure 14. In this technique, a plurality of sets of multiplexers (identified as $MS_{0,1,2...}$) each receive a respective plurality of waveforms, wherein a first plurality of waveforms for a first set of multiplexers has a different phase to a second plurality of waveforms for a second set of multiplexers. In the technique shown in Figure 14 (in which there are three sets of multiplexers), the sets of multiplexers receive a first, second and third plurality of waveforms respectively, wherein a plurality of waveforms for one set of multiplexers has a 120° phase difference with a plurality of waveforms for another set of multiplexers. The skilled person will understand that the phase difference between two sets of multiplexers (for a given number of sets of multiplexers) is equal to 360° divided by the total number of sets of multiplexers.

15

The plurality of waveforms from each set of multiplexers may then be used as an output for driving the printhead actuators. The skilled person will understand that this mechanism reduces the peak current flowing to the ground terminal.

20

The printhead actuator circuit 10, 60 may also be used for performing actuator and nozzle diagnostics. For example, a voltage signal may be taken from the actuator (instead of providing a voltage signal to the actuator) and sent to an external diagnostic system. These signals can then be analysed to assess the condition of the actuator and nozzle.

25

In the embodiments above, the multiplexers can be constructed from a variety of semiconductor switches and transmission gates. This ensures the direction of charging and discharging of the associated actuators, which are primarily a capacitive element. However, the skilled person will understand that any suitable circuit, using any suitable semiconductor switch, may be used for switching between the plurality of waveforms.

In the above embodiments, a shift register is used to send a selection signal to the multiplexers in order to determine which waveform should drive the printhead actuator. The shift register has been used to illustrate a simple and flexible way in which the invention may be used. However, the skilled person will understand that the present invention is not limited to this form of control. For example, any sort of register or controller may be used to cause the multiplexers to select an appropriate waveform from the plurality of waveforms.

Furthermore, in the above embodiments, the waveforms are typically represented from sinusoidal or square waves. The skilled person will understand that the flexibility of the present invention allows for a whole range of waveforms (whether generic or tailored) to be used to drive the printheads.

In the above embodiments, the printhead actuator circuits receive the data clock and pixel clock from a data controller. However, the skilled person will understand that the data and pixel clocks may be received from different devices.

The skilled person will understand that any combination of features is possible within the scope of the invention, as claimed.

CLAIMS

1. A printhead actuator circuit comprising
a signal generator arranged to generate a plurality of waveforms, wherein each waveform is
5 arranged to drive a printhead actuator;
a plurality of semiconductor switches, wherein each semiconductor switch is associated with
a waveform of the plurality of waveforms; and
an output connectable to a printhead actuator, wherein the plurality of semiconductor
switches are configured to selectively connect an associated waveform of the plurality of
10 waveforms to the output.
2. A printhead actuator circuit as claimed in Claim 1, further comprising a register
configured to send a selection signal to the plurality of semiconductor switches, the selection
signal causing the plurality of semiconductor switches to connect the associated waveform
15 of the plurality of waveforms to the output.
3. A printhead actuator circuit as claimed in Claim 2, wherein the selection signal
causes a subset of the plurality of semiconductor switches to connect a subset of waveforms
of the plurality of waveforms to the output.
20
4. A printhead actuator circuit as claimed in either Claim 2 or Claim 3, wherein the
register receives a configuration signal, wherein the configuration signal causes a particular
selection signal to be sent from the register to the plurality of semiconductor switches.

5. A printhead actuator circuit as claimed in Claim 4, wherein the configuration signal is sent at a first clock rate, the selection signal is sent to the plurality of semiconductor switches at a second clock rate, and the first and second clock rates are different.
- 5 6. A printhead actuator circuit as claimed in any one of Claims 2 to 5, wherein the plurality of waveforms are synchronized such that each waveform of the plurality of waveforms has substantially the same voltage at a transition point, the transition point being when the plurality of semiconductor switches receive the selection signal.
- 10 7. A printhead actuator circuit as claimed in Claim 6, wherein the voltage of each waveform of the plurality of waveforms at the predetermined transition point is substantially 0V.
8. A printhead actuator circuit as claimed in any one of Claims 2 to 7, wherein the
15 register is a shift register.
9. A printhead actuator circuit as claimed in any one of the preceding claims, wherein the plurality of semiconductor switches are arranged to form a multiplexer.
- 20 10. A printhead actuator circuit as claimed in Claim 9, wherein the multiplexer is one of a plurality of multiplexers and the output is one of a plurality of outputs connectable to a respective printhead actuator, wherein each multiplexer is configured to connect a waveform of the plurality of waveforms to one of the plurality of outputs.

11. A printhead actuator circuit as claimed in Claim 10, further comprising a plurality of registers, wherein each register is configured to send a selection signal to an associated multiplexer of the plurality of multiplexers, the selection signal causing the associated multiplexer to connect a predetermined waveform of the plurality of waveforms to one of the
5 plurality of outputs.
12. A printhead actuator circuit as claimed in Claim 11, wherein the selection signal causes a subset of the plurality of multiplexers to connect a subset of waveforms of the plurality of waveforms to one of the plurality of outputs.
- 10
13. A printhead actuator circuit as claimed in either Claim 11 or Claim 12, wherein the register receives a configuration signal, wherein the configuration signal includes an identifier of the associated waveform or subset of waveforms.
- 15
14. A printhead actuator circuit as claimed in Claim 13, wherein the configuration signal is sent at a first clock rate, the selection signal is sent to the plurality of semiconductor switches at a second clock rate, and the first and second clock rates are different.
- 20
15. A printhead actuator circuit as claimed in any one of Claims 11 to 14, wherein the plurality of waveforms are synchronized such that each waveform of the plurality of waveforms has substantially the same voltage at a transition point, the transition point being when the plurality of multiplexers receive the selection signal.
- 25
16. A printhead actuator circuit as claimed in Claim 15, wherein the voltage of each waveform of the plurality of waveforms at the predetermined transition point is about 0V.

17. A printhead actuator circuit as claimed in any one of Claims 11 to 16, wherein the register is a shift register.
- 5 18. A printhead actuator circuit as claimed in any one of the preceding claims, wherein the signal generator includes a dissipative element, the dissipative element being thermally isolated from the printhead actuator.
19. A printhead actuator circuit as claimed in Claim 18, wherein the dissipative element is
10 a bleed resistor.
20. A printhead actuator circuit as claimed in any one of the preceding claims, further comprising a plurality of outputs connectable to a plurality of printhead actuators, wherein the plurality of semiconductor switches are configured to selectively connect an associated
15 waveform of the plurality of waveforms to each output.
21. A printhead actuator as claimed in Claim 20, wherein the associated waveform for each output is tailored for a printhead actuator of the plurality of printhead actuator to which it is connected.
- 20 22. A printhead actuator circuit as claimed in any one of the preceding claims, wherein a first waveform of the plurality of waveforms is out of phase with a second waveform of the plurality of waveforms.

23. A printhead actuator circuit as claimed in any one of Claims 1 to 22, wherein the plurality of semiconductor switches are configured such that, on selectively connecting a waveform to the printhead actuator, successive peaks in the waveform increase in amplitude over a predetermined risetime.

5

24. A printhead actuator circuit as claimed in any one of Claims 10 to 23, wherein the plurality of multiplexers form one set of a plurality of sets of multiplexers, wherein each set of multiplexers are configured to receive a respective plurality of waveforms, wherein a first plurality of waveforms for a first set of multiplexers of the plurality of sets of multiplexers has
10 a different phase to a second plurality of waveforms for a second set of multiplexers of the plurality of sets of multiplexers.

25. A printhead including the printhead actuator circuit as claimed in any one of the preceding claims.

15

26. A printer comprising the printhead actuator circuit as claimed in any one of Claims 1 to 24.

27. A printhead actuator circuit substantially as herein described with reference to and as
20 shown in accompanying Figures 2 to 14.

28. A method of controlling a printhead actuator circuit, the printhead actuator circuit configured to selectively connect one of a plurality of waveforms to a printhead actuator, the method comprising the steps of:
25 driving the printhead actuator with a first waveform of the plurality of waveforms, and

switching to a second waveform of the plurality of waveforms, such that the printhead actuator is driven by the second waveform, wherein the first and second waveform are out of phase with each other.

5 29. A method as claimed in Claim 28, wherein the step of switching to the second waveform occurs at a transition point when the first and second waveform have substantially the same voltage.

10 30. A method as claimed in Claim 29, wherein the first waveform is trimmed at the transition point such that it has a different amplitude and/or shape.

31. A method as claimed in Claim 29 or Claim 30, wherein the second waveform is trimmed at the transition point such that it has a different amplitude and/or shape.

15 32. A method of controlling a printhead actuator circuit, the printhead actuator circuit configured to selectively connect one of a plurality of waveforms to a printhead actuator, the method comprising the steps of:
driving the printhead actuator with a first waveform of the plurality of waveforms, and
switching to a second waveform of the plurality of waveforms, such that the printhead
20 actuator is driven by the second waveform, wherein
successive peaks in the second waveform increase in amplitude over a predetermined rise time.

33. A method as claimed in Claim 34, wherein the printhead actuator circuit includes a plurality of semiconductor switches, and a length of the predetermined rise time is configured is determined by the characteristics of the plurality of semiconductor switches.
- 5 34. A method substantially as herein described with reference to and as shown in accompanying Figures 2 to 14.



Application No: GB1308126.0

Examiner: Marc Collins

Claims searched: 1-32

Date of search: 10 October 2014

Patents Act 1977: Search Report under Section 17

Documents considered to be relevant:

Category	Relevant to claims	Identity of document and passage or figure of particular relevance
X	1-32	US 2013/106933 A1 (KIM) See whole document especially figure 3.
X	1-32	JP H0911457 A (SEIKO EPSON CORPORATION) See EPODOC abstract, WPI Abstract Accession No. 1997-127756 and figures.
X	1-32	US 2007/070102 A1 (TAKATA) See whole document especially figure 9.
X	1-32	EP 1642718 A2 (SEIKO EPSON CORPORATION) See whole document especially figure 6.
X	1-32	JP 2005035085 A (KONICA MINOLTA HOLDINGS INC.) See EPODOC abstract, WPI Abstract Accession No. 2005-127622 and figure 2.

Categories:

X	Document indicating lack of novelty or inventive step	A	Document indicating technological background and/or state of the art.
Y	Document indicating lack of inventive step if combined with one or more other documents of same category.	P	Document published on or after the declared priority date but before the filing date of this invention.
&	Member of the same patent family	E	Patent document published on or after, but with priority date earlier than, the filing date of this application.

Field of Search:

Search of GB, EP, WO & US patent documents classified in the following areas of the UKC^X :

--

Worldwide search of patent documents classified in the following areas of the IPC

B41J

The following online and other databases have been used in the preparation of this search report

EPODOC, WPI

International Classification:

Subclass	Subgroup	Valid From
B41J	0002/045	01/01/2006