

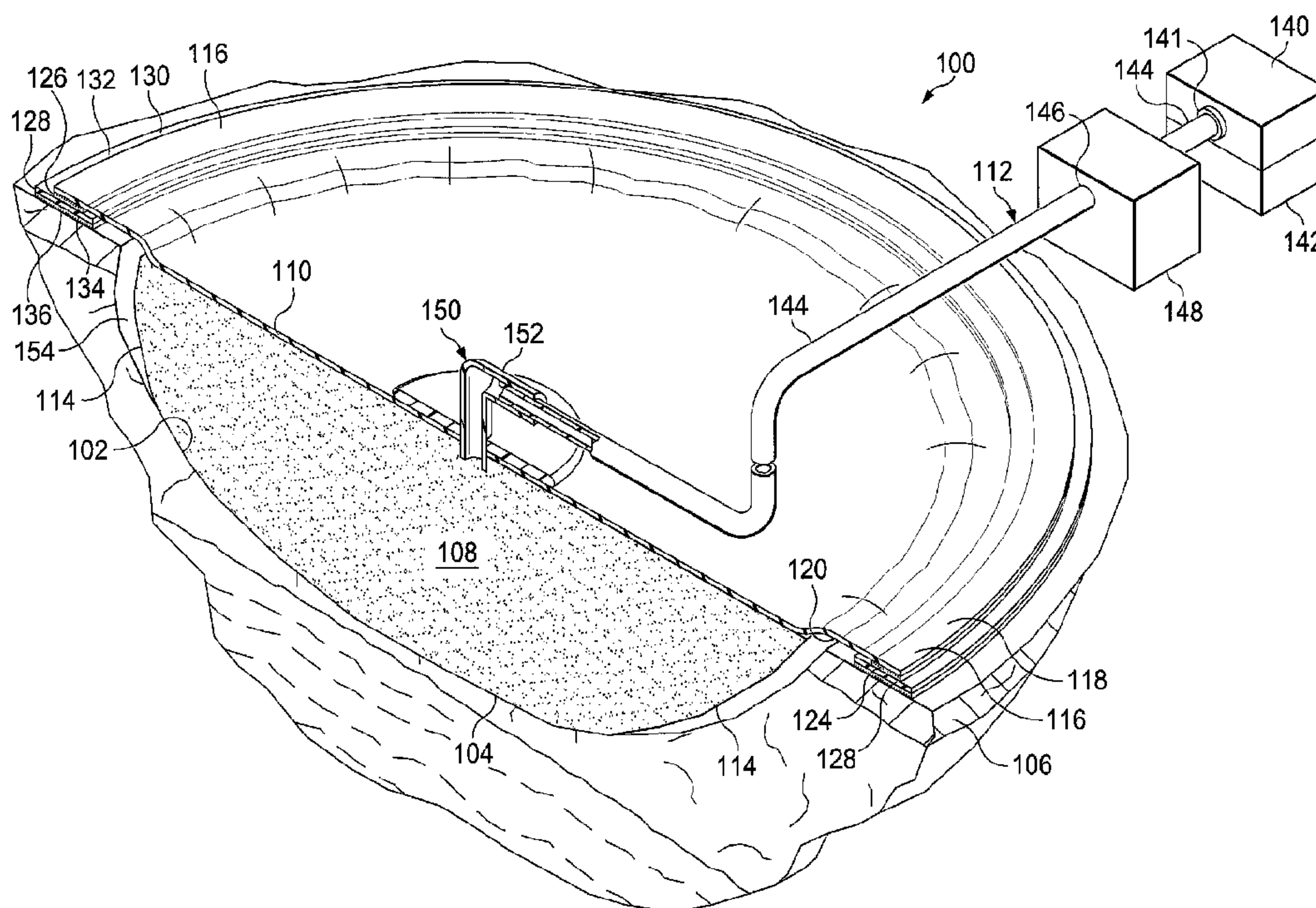

(86) **Date de dépôt PCT/PCT Filing Date:** 2008/08/20
 (87) **Date publication PCT/PCT Publication Date:** 2009/02/26
 (45) **Date de délivrance/Issue Date:** 2016/10/25
 (85) **Entrée phase nationale/National Entry:** 2010/02/19
 (86) **N° demande PCT/PCT Application No.:** US 2008/073749
 (87) **N° publication PCT/PCT Publication No.:** 2009/026385
 (30) **Priorité/Priority:** 2007/08/21 (US60/965,755)

(51) **Cl.Int./Int.Cl. A61M 27/00** (2006.01),
A61M 1/00 (2006.01)
 (72) **Inventeurs/Inventors:**
MORMINO, RICHARD PAUL, US;
FRUCHTERMAN, TODD MATTHEW, US
 (73) **Propriétaire/Owner:**
KCI LICENSING INC., US
 (74) **Agent:** BORDEN LADNER GERVAIS LLP

(54) **Titre : SYSTEME A PRESSION REDUITE ET PROCEDE EMPLOYANT UN JOINT D'ETANCHEITE**
 (54) **Title: REDUCED-PRESSURE SYSTEM AND METHOD EMPLOYING A GASKET**



(57) **Abrégé/Abstract:**

A reduced-pressure treatment system for treating a tissue site on a patient includes a gasket releasable attached around a perimeter of the tissue site that may remain in place for an extended time and allows an over-drape to be attached to it. The system and method further may include a manifold sized and configured to be placed in contact with the tissue site; the over-drape positioned over the manifold and sealed to the gasket to create a sealed space between the over-drape and the tissue site; and a reduced-pressure source fluidly coupled to the sealed space to deliver reduced pressure to the tissue site. A method is also presented.

(12) INTERNATIONAL APPLICATION PUBLISHED UNDER THE PATENT COOPERATION TREATY (PCT)

(19) World Intellectual Property Organization
International Bureau(43) International Publication Date
26 February 2009 (26.02.2009)

PCT

(10) International Publication Number
WO 2009/026385 A1(51) International Patent Classification:
A61B 17/08 (2006.01) A61D 1/00 (2006.01)(74) Agents: MASON, Robert, W. et al.; Kinetic Concepts,
Inc., P.O. Box 659508, San Antonio, TX 78265-9508 (US).(21) International Application Number:
PCT/US2008/073749(81) Designated States (unless otherwise indicated, for every
kind of national protection available): AE, AG, AL, AM,
AO, AT, AU, AZ, BA, BB, BG, BH, BR, BW, BY, BZ, CA,
CH, CN, CO, CR, CU, CZ, DE, DK, DM, DO, DZ, EC, EE,
EG, ES, FI, GB, GD, GE, GH, GM, GT, HN, HR, HU, ID,
IL, IN, IS, JP, KE, KG, KM, KN, KP, KR, KZ, LA, LC, LK,
LR, LS, LT, LU, LY, MA, MD, ME, MG, MK, MN, MW,
MX, MY, MZ, NA, NG, NI, NO, NZ, OM, PG, PH, PL, PT,
RO, RS, RU, SC, SD, SE, SG, SK, SL, SM, ST, SV, SY, TJ,
TM, TN, TR, TT, TZ, UA, UG, US, UZ, VC, VN, ZA, ZM,
ZW.

(22) International Filing Date: 20 August 2008 (20.08.2008)

(25) Filing Language: English

(26) Publication Language: English

(30) Priority Data:
60/965,755 21 August 2007 (21.08.2007) US(71) Applicant (for all designated States except US): KCI LI-
CENSING INC. [US/US]; Legal Department- Intellectual
Property, P.O. Box 659508, San Antonio, TX 78265-9508
(US).(84) Designated States (unless otherwise indicated, for every
kind of regional protection available): ARIPO (BW, GH,
GM, KE, LS, MW, MZ, NA, SD, SL, SZ, TZ, UG, ZM,
ZW), Eurasian (AM, AZ, BY, KG, KZ, MD, RU, TJ, TM),
European (AT, BE, BG, CH, CY, CZ, DE, DK, EE, ES, FI,
FR, GB, GR, HR, HU, IE, IS, IT, LT, LU, LV, MC, MT, NL,
NO, PL, PT, RO, SE, SI, SK, TR), OAPI (BF, BJ, CF, CG,
CI, CM, GA, GN, GQ, GW, ML, MR, NE, SN, TD, TG).

(72) Inventors; and

(75) Inventors/Applicants (for US only): MORMINO,
Richard, Paul [US/US]; 201 Delaware Street, San Anto-
nio, TX 78210 (US). FRUCHTERMAN, Todd, Matthew
[US/US]; 4 Hazlewood Court, San Antonio, TX 78257
(US).

Published:

— with international search report

(54) Title: REDUCED-PRESSURE SYSTEM AND METHOD EMPLOYING A GASKET

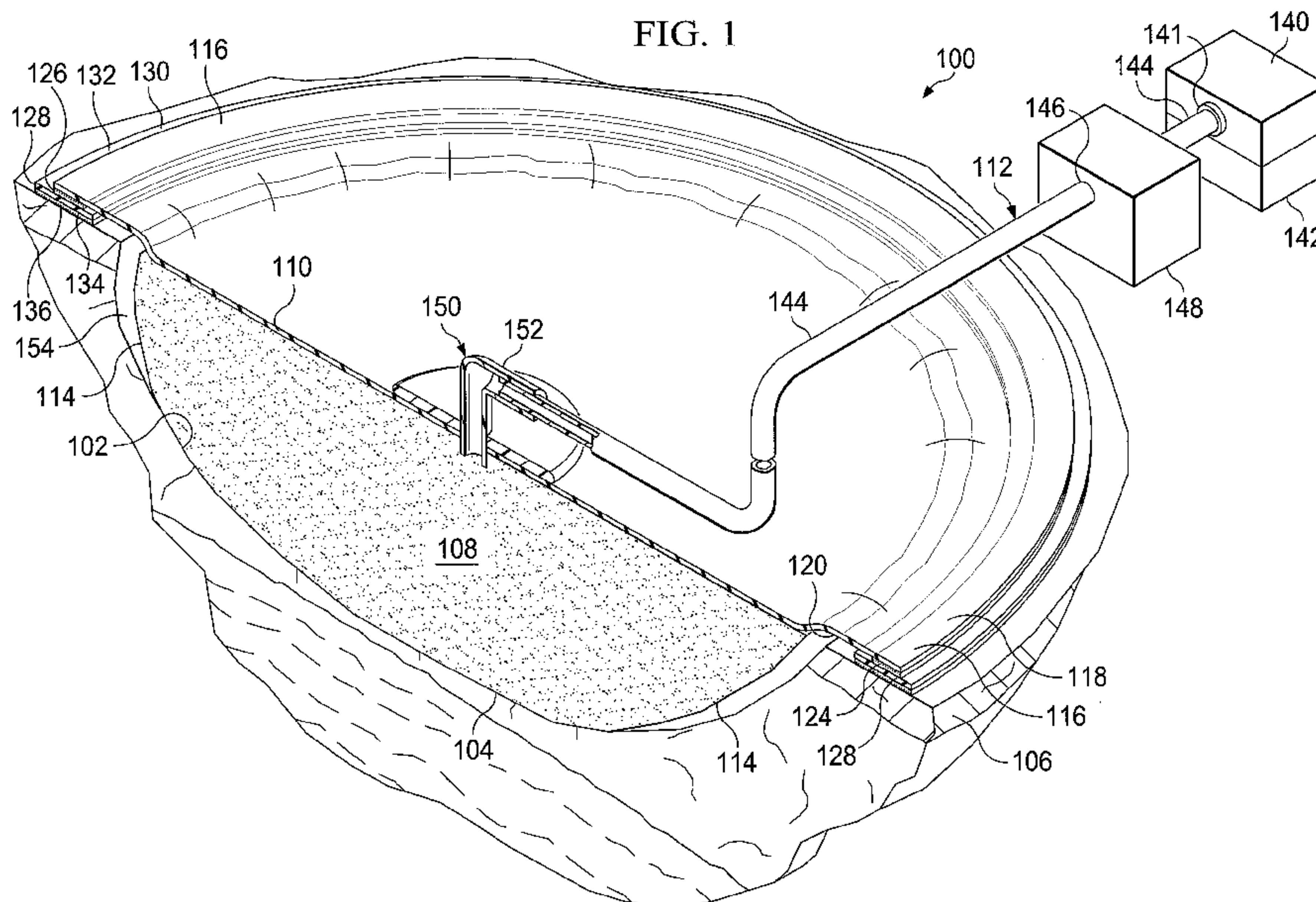

(57) Abstract: A reduced-pressure treatment system for treating a tissue site on a patient includes a gasket releasable attached around a perimeter of the tissue site that may remain in place for an extended time and allows an over-drape to be attached to it. The system and method further may include a manifold sized and configured to be placed in contact with the tissue site; the over-drape positioned over the manifold and sealed to the gasket to create a sealed space between the over-drape and the tissue site; and a reduced-pressure source fluidly coupled to the sealed space to deliver reduced pressure to the tissue site. A method is also presented.

WO 2009/026385 A1

REDUCED-PRESSURE SYSTEM AND METHOD EMPLOYING A GASKET**BACKGROUND****1. Field of the Invention**

5 The present invention relates generally to medical treatment systems and in particular to a reduced-pressure system and method employing a gasket.

2. Description of Related Art

Clinical studies and practice have shown that providing a reduced pressure in proximity to a tissue site augments and accelerates the growth of new tissue at the tissue site. 10 The applications of this phenomenon are numerous, but application of reduced pressure has been particularly successful in treating wounds. This treatment (frequently referred to in the medical community as “negative pressure wound therapy,” “reduced pressure therapy,” or “vacuum therapy”) provides a number of benefits, including faster healing and increased formulation of granulation tissue. Typically, reduced pressure is applied to tissue through a 15 porous pad or other manifold device. The porous pad contains cells or pores that are capable of distributing reduced pressure to the tissue and channeling fluids that are drawn from the tissue.

In order to use reduced pressure on a tissue site, a pneumatic seal is achieved over the dressing using a semi-permeable drape that is sealed to the patient’s epidermis. In order to 20 achieve this seal, an adhesive has been used at times or a sealing tape. At times, to help provide a better seal, healthcare providers have navigated the difficult task of using sealing material to form strips around the wound before placing the drape over the dressing and wound. With reduced-pressure therapy, a dressing is applied and usually is periodically changed. This typically means that the dressing is changed with some frequency—often three 25 times a week or more. When such changes take place, the sealing tape is removed. This can cause irritation to the periwound region and pain to the patient.

It would be desirable to have a system and method that would allow for wound dressing changes with less pain for the patient and without requiring removal of all 30 components of the system. It would also be desirable to provide a system that would be relatively easy to apply to a patient. Moreover, it would be desirable to have a system with a good pneumatic seal formed over the wound site.

SUMMARY

Problems with existing reduced-pressure systems and methods are addressed by the systems and methods of the illustrative embodiments described herein. According to one illustrative embodiment, a reduced-pressure treatment system for treating a tissue site on a patient includes a gasket releasably attached around a perimeter of the tissue site; a manifold sized and configured to be placed in contact with the tissue site; an over-drape positioned over the manifold and sealed to the gasket to create a sealed space between the over-drape and the tissue site; and a reduced-pressure source fluidly coupled to the sealed space to deliver reduced pressure to the tissue site. The gasket may be operable to remain in place for an extended time.

According to another illustrative embodiment, a method for treating a tissue site on a patient with reduced pressure includes the steps of: releasably attaching a gasket around a perimeter of the tissue site; placing a manifold in contact with the tissue site; disposing an over-drape over the manifold; sealing the over-drape to the gasket to create a sealed space between the over-drape and the tissue site; and providing reduced pressure to the sealed space to treat the tissue site.

The illustrative embodiment of the systems and methods of the present invention may provide for a number of perceived advantages. A few examples follow. Technical advantages of the present invention may include that system is relatively easy to apply. Another advantage is the system may be easier on the periwound region of the epidermis. Another advantage is that the patient may experience relatively reduced or eliminated pain associated with dressing changes. Another advantage is that the likelihood of pneumatic leak is decreased. These are only some examples.

Other objects, features, and advantages of the illustrative embodiments will become apparent with reference to the drawings and detailed description that follow

BRIEF DESCRIPTION OF THE DRAWINGS

FIGURE 1 is a schematic, perspective view with a portion in cross-section of an illustrative embodiment of a reduced-pressure system employing a gasket;

FIGURE 2 is a schematic, plan view of an illustrative embodiment of a gasket disposed
5 circumferentially around a tissue site;

FIGURE 3 is a schematic, perspective view of an illustrative embodiment of a dispenser for applying an illustrative gasket to a periwound area of a patient's epidermis; and

FIGURE 4 is a schematic, cross-sectional view of a portion of an illustrative embodiment of a reduced-pressure system employing a gasket.

10

DETAILED DESCRIPTION OF ILLUSTRATIVE EMBODIMENTS

In the following detailed description of the illustrative embodiments, reference is made to the accompanying drawings that form a part hereof. These embodiments are described in sufficient detail to enable those skilled in the art to practice the invention, and it is understood that other embodiments may be utilized and that logical structural, mechanical, electrical, and chemical changes may be made. To avoid
15 detail not necessary to enable those skilled in the art to practice the embodiments described herein, the description may omit certain information known to those skilled in the art. The following detailed description is, therefore, not to be taken in a limiting sense, and the scope of the illustrative embodiments are defined only by the appended claims.

Referring to FIGURE 1, an illustrative embodiment of a reduced-pressure treatment system 100 for
20 treating a wound 102 at a tissue site 104, which is centered in a wound bed. System 100 may include a manifold member 108, or simply manifold; an over-drape 110; and a reduced-pressure subsystem 112. System 100 includes gasket 128.

In one illustrative embodiment, the manifold member 108 is made from a porous and permeable foam-like material and, more particularly, a reticulated, open-cell polyurethane or polyether foam that
25 allows good permeability of wound fluids while under a reduced pressure. One such foam material that has been used is the VAC® Granufoam® Dressing available from Kinetic Concepts, Inc. (KCI) of San Antonio, Texas. Any material or combination of materials might be used for the manifold material provided that the manifold material is operable to distribute the reduced pressure. The term "manifold" as used herein generally refers to a substance or structure that is provided to assist in applying reduced
30 pressure to, delivering fluids to, or removing fluids from a tissue site. A manifold typically includes a plurality of flow channels or pathways that are interconnected to improve distribution of fluids provided to and removed from the area of tissue around the manifold. Examples of manifolds

may include without limitation devices that have structural elements arranged to form flow channels, cellular foam, such as open-cell foam, porous tissue collections, and liquids, gels, and foams that include or cure to include flow channels. The manifold material might also be a combination or layering of materials; for example, a first manifold layer of hydrophilic foam
5 might be disposed adjacent to a second manifold layer of hydrophobic foam to form the manifold member 108.

The reticulated pores of the Granufoam[®] material, that are in the range of about 400 to 600 microns, are helpful in carrying out the manifold function, but again other materials may be used. A material with a higher, or lower, density (smaller pore size) than Granufoam[®]
10 material may be desirable in some situations. The manifold member 108 may also be a reticulated foam that is later felted to thickness of about 1/3 its original thickness. Among the many possible materials, the following might be used: Granufoam[®] material or a Foamex technical foam (www.foamex.com). In some instances it may be desirable to add ionic silver to the foam in a microbonding process or to add other substances to the manifold member such
15 as antimicrobial agents. The manifold member 108 could be a bio-absorbable material or an anisotropic material.

The over-drape 118 covers the manifold member 108 and extends past a peripheral edge 114 of the manifold member 108 to form a drape extension 116. Drape extension 116 has a first side 118 and a second, patient-facing side 120. Drape extension 116 may be sealed
20 against a gasket 128 by sealing apparatus 124, such as an adhesive 126. Sealing apparatus 124 may take numerous forms, such as an adhesive sealing tape, or drape tape or strip; double-side drape tape; adhesive 126; paste; hydrocolloid; hydrogel; or other sealing means. If a tape is used, it may be formed of the same material as the over-drape 110 with a pre-applied, pressure-sensitive adhesive. Pressure-sensitive adhesive 126 may be applied on a second,
25 patient-facing side 120 of drape extension 116. Adhesive 126 provides a substantially pneumatic seal between the over-drape 110 and the gasket 128. Before the over-drape 110 is secured to the patient, removable strips covering the adhesive 126 may be removed.

Over-drape 110 may be an elastomeric material that has pore sizes less than about 20 microns, but other materials and sizes might be used. "Elastomeric" means having the
30 properties of an elastomer and generally refers to a polymeric material that has rubber-like properties. More specifically, most elastomers have elongation rates greater than 100% and a significant amount of resilience. The resilience of a material refers to the material's ability to recover from an elastic deformation. Examples of elastomers may include, but are not limited to, natural rubbers, polyisoprene, styrene butadiene rubber, chloroprene rubber, polybutadiene,
35 nitrile rubber, butyl rubber, ethylene propylene rubber, ethylene propylene diene monomer,

chlorosulfonated polyethylene, polysulfide rubber, polyurethane, EVA film, co-polyester, and silicones. Further still, over-drape materials may include a silicone, 3M Tegaderm® drape material, acrylic drape material, such as one available from Avery, or an incise drape material.

Gasket 128 has a gasket material 130 with a first side 132 and a second, patient-facing side 134. A second attachment apparatus 136 may be coupled to the second side 134 of the gasket material 130 for releasably attaching the gasket 128 to the patient's epidermis 106, or more generally skin. The gasket material 130 may be a thin polymer film, such as polyurethane, polyester, silicone, or a hydrocolloid, or could include any suitable gasket material. The second attachment apparatus 136 holding the gasket 128 in place may be a relatively water-resistant material, such as an Avery® brand Wet-stick adhesive, a colloid, acrylic, polyisobutylene (PIB), etc. The second attachment apparatus 136 allows the gasket 128 to be held in place for an extended time, e.g. one to two weeks or more, and then to be removed. The over-drape 110 may be re-attachable to the gasket 128 should the clinician find a need to view the wound and re-attach the over-drape 110. This allows the gasket 128 to stay in place for an extended time without significant agitation of the periwound area of the epidermis 106.

Reduced-pressure subsystem 112 includes a reduced-pressure source 140, which can take many different forms. Reduced-pressure source 140 provides a reduced pressure as a part of system 100. The term "reduced pressure" as used herein generally refers to a pressure less than the ambient pressure at a tissue site 104 that is being subjected to treatment. In most cases, this reduced pressure will be less than the atmospheric pressure at which the patient is located. Alternatively, the reduced pressure may be less than a hydrostatic pressure of tissue at the tissue site 104. It is often desirable for the reduced-pressure source 140 to develop a continuous reduced pressure below atmospheric pressure and also be able to deliver a dynamic pressure, i.e., to vary the reduced pressure in a cycle or operate in a continuous or intermittent mode. The operable range of reduced pressure may vary widely as needed, but would typically include 200 mm Hg below atmospheric. When one refers to increasing the reduced pressure, it typically refers to increasing the absolute value of the negative gauge pressure, and likewise, when one speaks of decreasing the reduced pressure, it typically means that the absolute value of the negative gauge pressure is decreasing.

In the illustrative embodiment of FIGURE 1, reduced-pressure source 140 is shown having a reservoir region 142, or canister region. An interposed membrane filter, such as hydrophobic or oleophobic filter, might be interspersed between a delivery conduit, or tubing, 144 and the reduced-pressure source 140. A medial portion 146 of conduit 144 may have one or more devices, such as device 148. For example, the device 148 might be another fluid

reservoir, or collection member to hold exudates and other fluids removed. Other examples of devices 148 that might be included on the medial portion 146 of delivery conduit 144 include pressure-feedback devices, volume detection systems, blood detection systems, infection detection system, flow monitoring systems, temperature monitoring systems, etc. Some of
5 these devices may be formed integral to the reduce-pressure source 140. For example, a reduced-pressure port 141 on reduced-pressure source 140 may include a filter member that includes one or more filters, e.g., an odor filter.

The reduced pressure developed by reduce-pressure source 140 is delivered through the delivery conduit 144 to a reduced-pressure interface 150, which might be an elbow port
10 152. In one illustrative embodiment, port 152 is a TRAC[®] technology port available from Kinetic Concepts, Inc. of San Antonio, Texas. Interface 150 allows the reduced pressure to be delivered through over-drape 110 and realized within sealed space 154. In this illustrative embodiment, elbow port 152 extends through over-drape 110 and into manifold member 108.

Referring now to FIGURE 2, an illustrative embodiment of a gasket 200 is shown
15 disposed circumferentially about wound 202. A small margin 204 is shown at the wound edge 206. It will be appreciated from FIG. 2 that irregular shaped wounds, such as wound 202, should be accommodated. One way to accommodate the irregular shape is to attach gasket 200 using a gasket tape, i.e., a gasket material with attachment means that can be applied to the patient like a tape. In this regard, FIGURE 3, shows an illustrative embodiment of a
20 gasket tape dispenser 300.

Gasket tape dispenser 300 dispenses gasket 302, or gasket tape, which has a gasket material 304 and an attachment apparatus 306. The dispenser 300 may take many forms, but in this embodiment, contains a first chamber portion 308, which holds a roll of gasket tape 302. The healthcare provider can thus use the dispenser 300 to dispense gasket 302 about the
25 perimeter of the tissue site proximate wound 310 on or through epidermis 311. To do so, the dispenser 300 is moved in the direction shown by arrow 314. In some instances, it may be desirable to include a releasable backing material on the attachment means 306 until it is ready for application; in such a situation, a second chamber 312 (shown in broken lines) may be included for collecting the removed backing material. The second chamber 312 may include a
30 spring-loaded spindle that pulls the removed backing material on to it. There are numerous other ways the gasket 302 might be dispensed.

Referring again to FIGURE 2, in operation, the healthcare provider treating a wound 202 may, after appropriately cleaning and preparing the periwound region, apply a gasket 200 about the wound 202 using a dispenser, such as dispenser 300 in FIG. 3, or otherwise placing
35 the gasket 200 proximate the wound 202. The gasket 200 provides a long-lasting perimeter

about the wound 202 that facilitates attachment of an over-drape and that allows the over-drape to be removed without requiring the gasket 200 to be removed. By “long-lasting,” it is meant that the gasket 200 could remain attached and operable for as long as one to two weeks or even longer.

Referring again to FIGURE 1 and continuing consideration of one illustrative embodiment in operation, once the gasket 128 has been applied in a manner analogous to that just described for gasket 200 and the manifold 108 put in place, the over-drape 110 may be placed over the wound 102 and attachment apparatus 124 used to secure the over-drape 110 to the gasket 128 and in particular to releasably attach drape extension 116 to the gasket 128. In this instance, attachment apparatus 124 is an adhesive layer 126 and requires removal of a removable backing before application. Once over-drape 110 is sealed, it provides the pneumatically sealed space 154. The reduced-pressure interface 150 is applied through over-drape 110 to allow reduced pressure from reduced-pressure subsystem 112 to reach the manifold 108. The reduced-pressure subsystem 112 may be activated and reduced pressure supplied to manifold 108 in sealed spaced 154.

Referring now to FIGURE 4, another illustrative embodiment for releasably sealing over-drape 402 to first side 404 of gasket 406 is shown. Gasket 406 has a sealing apparatus 408 on a second, patient-facing side 410 that holds and seals the gasket 406 in a long-lasting way to the patient’s epidermis 412. In this illustrative embodiment, the over-drape 402 is secured using a bead 414 of adhesive applied to the first side 404 of the gasket 406 and against a second, patient-facing side 416 of over-drape 402. The bead 414 may be applied using an applicator similar to a caulk gun. In still another illustrative embodiment, a material capable of drying and adhering to a patient’s epidermis periwound might be painted on or sprayed on and allowed to dry.

It should be apparent from the foregoing that an invention having significant advantages has been provided. The scope of the claims should not be limited by the embodiments set forth in the examples, but should be given the broadest interpretation consistent with the description as a whole.

CLAIMS

What is claimed is:

1. A reduced-pressure treatment system for treating a tissue site on a patient, the system comprising:
 - a gasket releasably attached around a perimeter of the tissue site, wherein the gasket comprises a gasket material, and wherein the gasket has a first side and a second, patient-facing side;
 - a manifold sized and configured to be placed in contact with the tissue site;
 - an over-drape positioned over the manifold and releasably sealed to the gasket by a bead of a first adhesive between the over-drape and the first side of the gasket, and wherein the gasket is sealed to the patient's epidermis by a second adhesive between the second, patient-facing side of the gasket and the patient's epidermis, to create a sealed space between the over-drape and the tissue site, the over-drape comprising an elastomeric film, and wherein the first adhesive is weaker than the second adhesive; and
 - a reduced-pressure source fluidly coupled to the sealed space to deliver reduced pressure to the tissue site.
2. The reduced-pressure treatment system of Claim 1, wherein the tissue site is a wound bed and further comprising a gasket tape dispenser for applying the gasket around the perimeter of the tissue site.
3. The reduced-pressure treatment system of Claim 1, wherein the gasket material comprises a thin polymer film.
4. The reduced-pressure treatment system of Claim 3, wherein the thin polymer film comprises polyurethane.
5. The reduced-pressure treatment system of Claim 3, wherein the thin polymer film comprises polyester.

6. The reduced-pressure treatment system of Claim 1, wherein the gasket material comprises a hydrocolloid.
7. The reduced-pressure treatment system of Claim 1, wherein the second adhesive is water resistant to maintain the gasket releasably attached around the perimeter of the tissue site for one week.
8. The reduced-pressure treatment system of Claim 1, wherein the second adhesive is water resistant to maintain the gasket releasably attached around the perimeter of the tissue site for two weeks.
9. A reduced-pressure treatment system for treating a tissue site on a patient, the system comprising:
 - a gasket for releasably attaching proximate the tissue site;
 - a manifold sized and configured to be placed in contact with the tissue site;
 - an over-drape placed over the manifold and sealed to the gasket to provide a sealed space between the over-drape and the tissue site;
 - a reduced-pressure source operable to deliver reduced pressure to a sealed space; and
 - a delivery conduit for fluidly coupling the reduced-pressure source to the manifold;wherein the over-drape is sealed to the gasket by a bead of a first attachment apparatus between the over-drape and a first side of the gasket;
wherein a second attachment apparatus is disposed on a second side of the gasket adapted for attachment proximate the tissue site; and
wherein the first attachment apparatus is weaker than the second attachment apparatus.
10. The reduced-pressure treatment system of Claim 9, wherein the first attachment apparatus is a first adhesive and the second attachment apparatus is a second adhesive.
11. The reduced-pressure treatment system of Claim 9, wherein the gasket comprises a thin polymer film.
12. The reduced-pressure treatment system of Claim 11, wherein the thin polymer film

comprises polyurethane.

13. The reduced-pressure treatment system of Claim 11, wherein the thin polymer film comprises polyester.
14. The reduced-pressure treatment system of Claim 9, wherein the gasket comprises a hydrocolloid.
15. The reduced-pressure treatment system of Claim 9, wherein the second attachment apparatus is water resistant to maintain the gasket releasably attached proximate the tissue site for one week.
16. The reduced-pressure treatment system of Claim 9, wherein the second attachment apparatus is water resistant to maintain the gasket releasably attached proximate the tissue site for two weeks.
17. Use, for treating a tissue site on a patient with reduced pressure, of:
 - a gasket releasably attached around a perimeter of the tissue site, the gasket comprising a first side and a second, patient-facing side;
 - a manifold placeable in contact with the tissue site;
 - an over-drape disposable over the manifold and tissue site;
 - the over-drape sealable to the gasket by a bead of a first attachment apparatus between the over-drape and the first side of the gasket, a sealed space providable between the over-drape and the tissue site, wherein a second attachment apparatus is disposable on the second, patient-facing side of the gasket adapted for attachment around the perimeter of the tissue site, the first attachment apparatus being weaker than the second attachment apparatus; and
 - wherein reduced pressure is providable to the sealed space for treatment of the tissue site.

18. The use of Claim 17, wherein the tissue site is a wound bed.
19. The use of Claim 17, wherein the first attachment apparatus is a first adhesive and the second attachment apparatus is a second adhesive.
20. The use of Claim 17, wherein the gasket comprises a thin polymer film.
21. The use of Claim 20, wherein the thin polymer film comprises polyurethane.
22. The use of Claim 20, wherein the thin polymer film comprises polyester.
23. The use of Claim 17, wherein the gasket comprises a hydrocolloid.
24. The use of Claim 17, wherein the second attachment apparatus is water resistant to maintain the gasket releasably attached around the perimeter of the tissue site for one week.
25. The use of Claim 17, wherein the second attachment apparatus is water resistant to maintain the gasket releasably attached around the perimeter of the tissue site for two weeks.
26. A reduced-pressure treatment system, comprising:
 - a manifold;
 - a gasket comprising a first side and a second side;
 - an over-drape placed over the manifold and attached to the first side of the gasket; and
 - a reduced-pressure source coupled to the manifold and operable to deliver reduced pressure to the manifold;wherein the over-drape is sealed to the gasket by a bead of a first attachment apparatus;
 - wherein a second attachment apparatus is disposed on the second side of the gasket and adapted to be attached to a periwound area of an epidermis; and
 - wherein the first attachment apparatus is weaker than the second attachment apparatus.

27. The reduced-pressure treatment system of Claim 26, wherein the first attachment apparatus is a first adhesive and the second attachment apparatus is a second adhesive.
28. The reduced-pressure treatment system of Claim 26, wherein the gasket is a gasket tape.
29. The reduced-pressure treatment system of Claim 26, wherein the manifold comprises a reticulated open-cell foam.
30. A system adapted for assembly to treat tissue, comprising:
 - a manifold adapted for placement proximate to the tissue;
 - a gasket adapted for placement on a periwound area around the tissue;
 - an over-drape adapted to cover the manifold member and to extend past a peripheral edge of the manifold member to form a drape extension;
 - a first attachment apparatus adapted for application between the drape extension and the gasket; and
 - a second attachment apparatus adapted for application between the gasket and the periwound area;wherein the first attachment apparatus is weaker than the second attachment apparatus.
31. The system of Claim 30, wherein the first attachment apparatus is a tape.
32. The system of Claim 30, wherein the first attachment apparatus is a pressure-sensitive adhesive.
33. The system of Claim 30, wherein the first attachment apparatus is a bead of adhesive.
34. The system of Claim 30, wherein the second attachment apparatus is a bead of adhesive.

FIG. 2

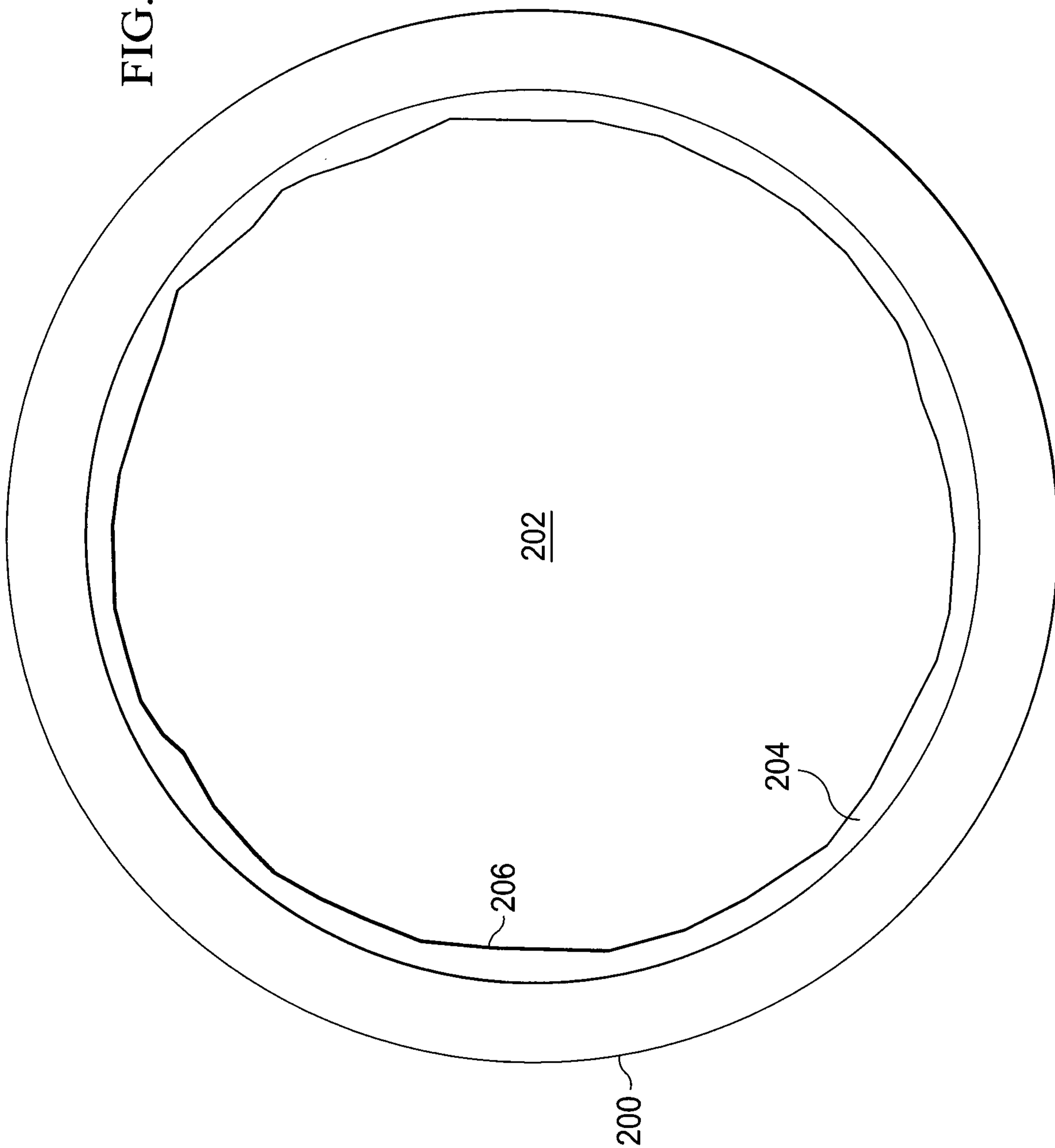

3/4

FIG. 3

