



US00D705132S

(12) **United States Design Patent**  
**Ware et al.**

(10) **Patent No.:** **US D705,132 S**

(45) **Date of Patent:** **\*\* May 20, 2014**

(54) **VEHICLE BODY EXTERIOR**

(71) Applicants: **John H. Ware**, Sao Paulo (BR); **Steve S. Kim**, Seoul (KR); **Vicente D. Beire**, Sao Paulo (BR); **Eduardo H Mine**, B. Barcelona (BR); **Marcos Miwa**, Saude (BR)

(72) Inventors: **John H. Ware**, Sao Paulo (BR); **Steve S. Kim**, Seoul (KR); **Vicente D. Beire**, Sao Paulo (BR); **Eduardo H Mine**, B. Barcelona (BR); **Marcos Miwa**, Saude (BR)

(73) Assignee: **GM Global Technology Operations LLC**, Detroit, MI (US)

(\*\*) Term: **14 Years**

(21) Appl. No.: **29/435,107**

(22) Filed: **Oct. 19, 2012**

(51) **LOC (10) Cl.** ..... **12-08**

(52) **U.S. Cl.**  
USPC ..... **D12/92**

(58) **Field of Classification Search**  
USPC ..... D12/86, 90-92; D21/424, 433, 434;  
296/181.1, 181.5  
See application file for complete search history.

(56) **References Cited**

**U.S. PATENT DOCUMENTS**

D592,105 S	5/2009	Dean et al.
D597,447 S	8/2009	Folden
D605,083 S	12/2009	Manoogian, II et al.
D605,978 S	12/2009	Wolff et al.
D608,690 S	1/2010	Folden et al.
D608,691 S	1/2010	Zak, Jr. et al.
D609,608 S	2/2010	Boniface et al.
D611,387 S	3/2010	Thompson et al.

D613,645 S	4/2010	Song et al.	
D615,458 S	5/2010	Thompson et al.	
D626,456 S	*	11/2010	Miyata et al. .... D12/92
D626,457 S	*	11/2010	Lian et al. .... D12/92
D628,939 S	*	12/2010	Komuro .... D12/92
D630,557 S	*	1/2011	Eum .... D12/92
D635,488 S		4/2011	Phipps
D644,567 S		9/2011	Kozub
D646,205 S	*	10/2011	Bittner et al. .... D12/92
D668,182 S	*	10/2012	Barba Franco et al. .... D12/92
D686,536 S	*	7/2013	McCabe et al. .... D12/92

**OTHER PUBLICATIONS**

Design U.S. Appl. No. 29/392,615, filed May 24, 2011; First Named Inventor: Carlos M. Barba Franco; Title: Vehicle Body.

Design U.S. Appl. No. 29/406,032, filed Nov. 9, 2011; First Named Inventor: In Ho Song; Title: Vehicle Body.

(Continued)

*Primary Examiner* — Melody Brown

(74) *Attorney, Agent, or Firm* — Lionel D. Anderson; Reising Ethington P.C.

(57) **CLAIM**

The ornamental design for a vehicle body exterior, as shown and described.

**DESCRIPTION**

FIG. 1 is a front view of a vehicle body exterior; FIG. 2 is a perspective view of the vehicle body exterior; FIG. 3 is a right side view of the vehicle body exterior; FIG. 4 is a top view of the vehicle body exterior; FIG. 5 is a perspective view of the vehicle body exterior; and, FIG. 6 is a rear view of the vehicle body exterior. In the drawings, the portions shown by broken lines form no part of the claim, and the left side view of the vehicle body exterior is omitted because the left side view is identical to the right side view.

**1 Claim, 6 Drawing Sheets**

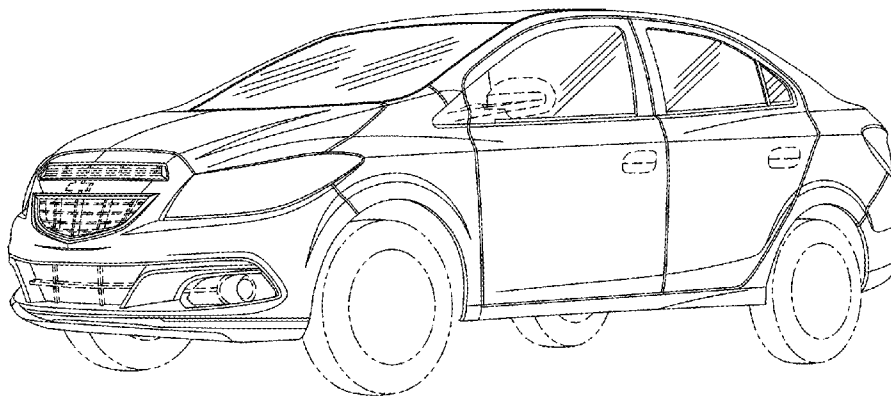

(56)

**References Cited**

OTHER PUBLICATIONS

Design U.S. Appl. No. 29/406,041, filed Nov. 9, 2011; First Named Inventor: Morio Ikeda; Title: Vehicle Body.

Design U.S. Appl. No. 29/407,580, filed Nov. 30, 2011; First Named Inventor: Robert J. Munson; Title: Vehicle Body.

Design U.S. Appl. No. 29/414,260, filed Feb. 27, 2012; First Named Inventor: Steven M. McCabe; Title: Vehicle Body.

Design U.S. Appl. No. 29/416,870, filed Mar. 28, 2012; First Named Inventor: Joshua L. Thurber; Title: Vehicle Body.

Design U.S. Appl. No. 29/428,494, filed Jul. 31, 2012; First Named Inventor: Morio Ikeda; Title: Vehicle Body Exterior.

\* cited by examiner

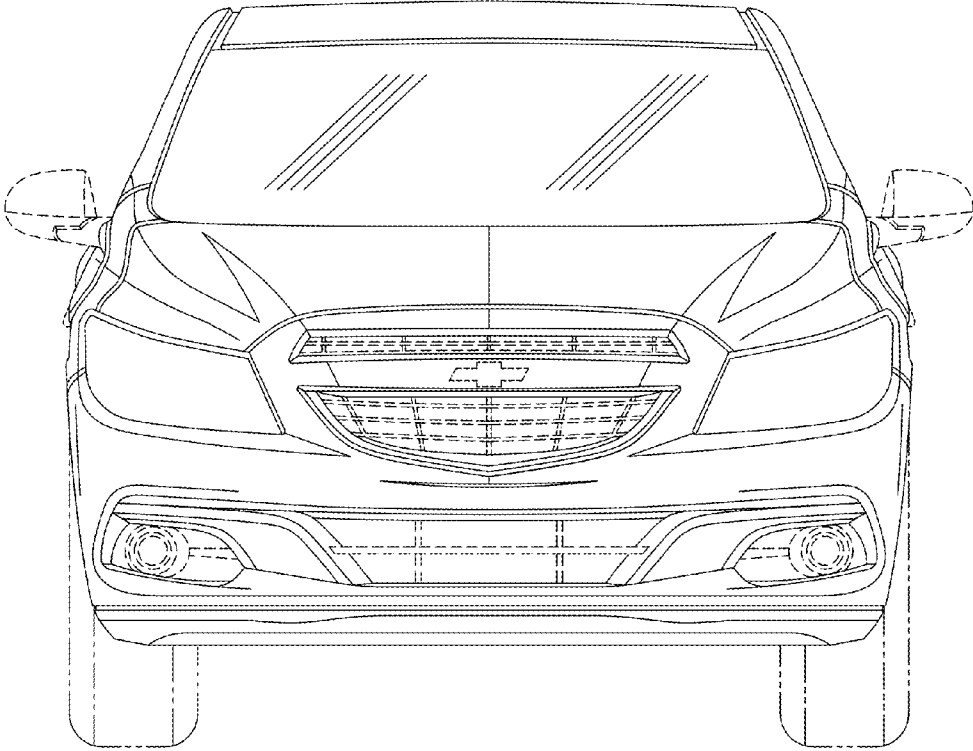

Fig-1

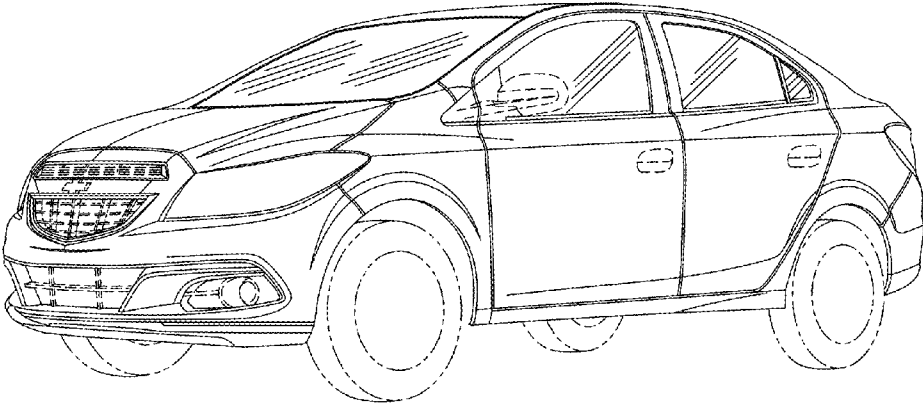

Fig-2

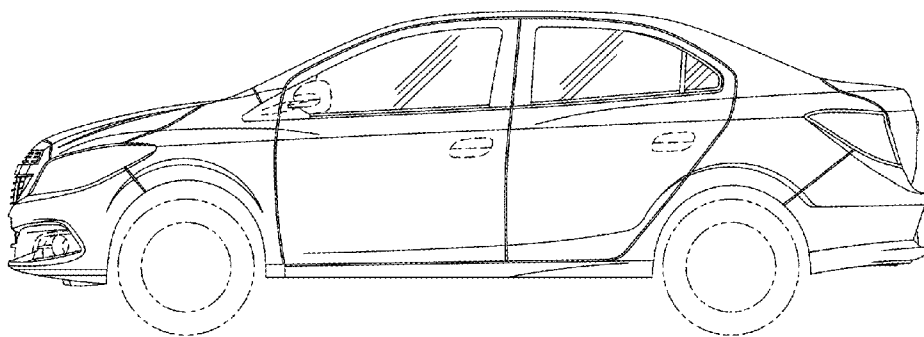

Fig-3

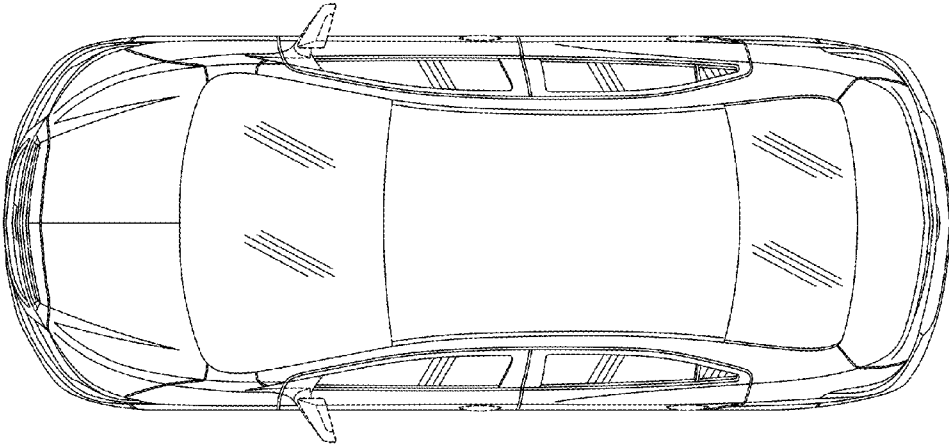

Fig-4

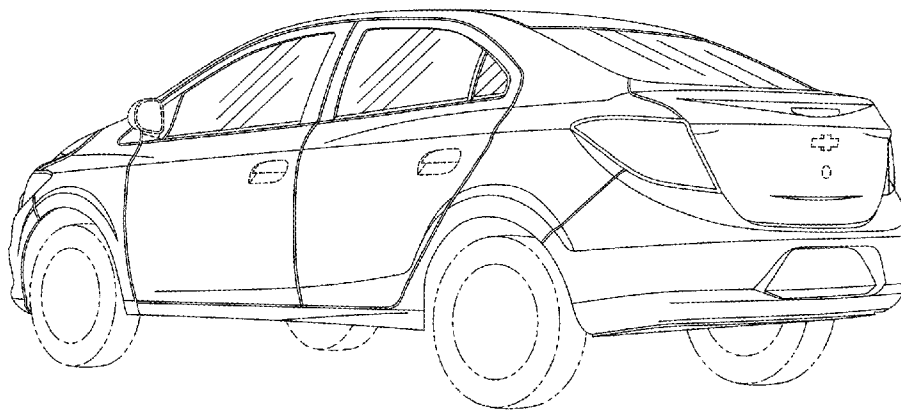

Fig-5

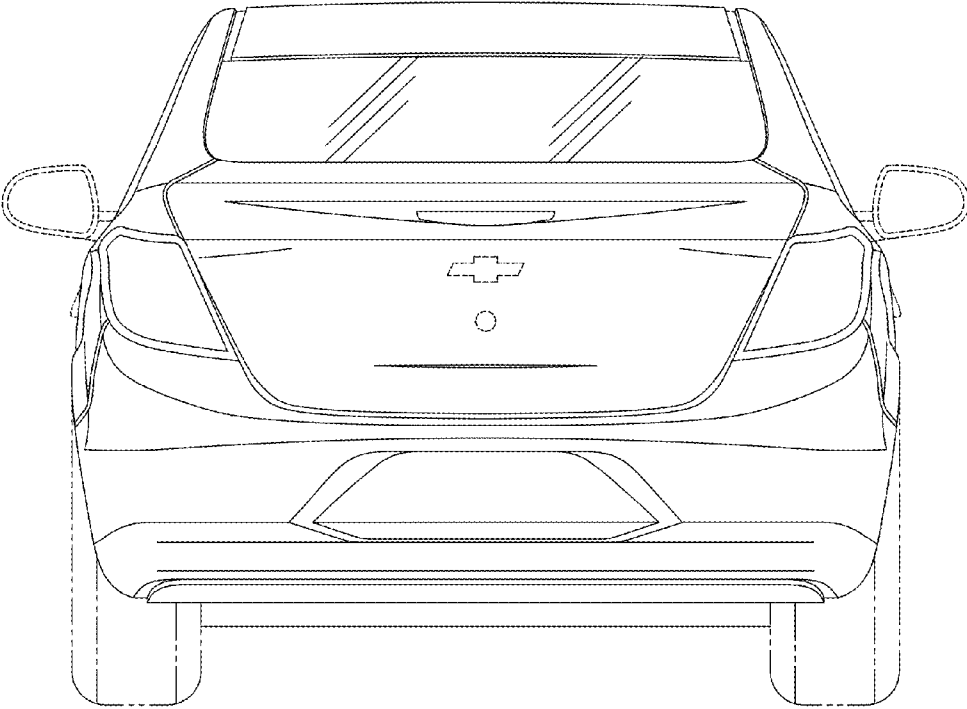

Fig-6