



US00D352044S

# United States Patent [19]

[11] Patent Number: **Des. 352,044**

**Hahn**

[45] Date of Patent: **\*\* Nov. 1, 1994**

[54] **BUCKET TOOTH**

[57] **CLAIM**

[75] Inventor: **Frederick C. Hahn, Aloha, Oreg.**

The ornamental design for a bucket tooth, as shown and described.

[73] Assignee: **Bucyrus Blades, Inc., Bucyrus, Ohio**

### DESCRIPTION

[\*\*] Term: **14 Years**

FIG. 1 is a front perspective view of a bucket tooth, showing the new design;

[21] Appl. No.: **6,324**

FIG. 2 is a left side elevational view of the bucket tooth shown in FIG. 1, the right side being a mirror image;

[22] Filed: **Mar. 26, 1993**

FIG. 3 is a top plan view of the bucket tooth shown in FIG. 1;

[52] U.S. Cl. .... **D15/29**

FIG. 4 is a bottom plan view of the bucket tooth shown in FIG. 1;

[58] Field of Search ..... **37/452-458;**

**D15/10, 22-26, 28-29, 32**

FIG. 5 is a front end elevational view of the bucket tooth shown in FIG. 1;

[56] **References Cited**

### U.S. PATENT DOCUMENTS

D. 228,936	10/1973	Dahlberg .	
D. 255,119	5/1980	Korpi .....	D15/29
D. 284,010	5/1986	Voyce .	
D. 309,460	7/1990	Gross .....	D15/29
D. 328,466	8/1992	Robinson .	
D. 329,243	9/1992	Robinson .	
D. 336,304	6/1993	Robinson .	
2,213,925	9/1940	Van Buskirk .....	37/453
2,689,419	9/1954	Daniels et al. .	
2,707,343	5/1955	Baer .	
3,136,077	6/1964	Troeppl .	
3,225,467	12/1965	Troeppl .	
3,326,302	6/1967	Washbond et al. .	
3,426,459	2/1969	Petersen .	
3,444,633	5/1969	Hensley .....	37/452
3,621,594	11/1971	Hahn et al. ....	57/457
3,729,055	4/1973	Burridge .	
3,959,901	6/1976	Klett .	
4,083,605	4/1978	College et al. .	
4,269,274	5/1981	Robertson et al. .	
4,321,762	3/1982	Hemphill .....	37/452
4,360,981	11/1982	Blerwith et al. .	
4,835,888	6/1989	Hemphill .	
4,965,945	10/1990	Emrich .....	37/456

### OTHER PUBLICATIONS

Pacific Alloy Castings vol. II, p. 4 Drill Point CCCP-1.

*Primary Examiner*—Melvin B. Feifer

*Assistant Examiner*—Sandra Morris

*Attorney, Agent, or Firm*—Banner, Birch, McKie and Beckett

FIG. 6 is a rear end elevational view of the bucket tooth shown in FIG. 1;

FIG. 7 is a cross sectional view taken along line 7—7 of FIG. 2;

FIG. 8 is a front perspective view of a second embodiment of a bucket tooth, showing the new design;

FIG. 9 is a left side elevational view of the bucket tooth shown in FIG. 8, the right side being a mirror image;

FIG. 10 is a top plan view of the bucket tooth shown in FIG. 8;

FIG. 11 is a bottom plan view of the bucket tooth shown in FIG. 8;

FIG. 12 is a front end elevational view of the bucket tooth shown in FIG. 8;

FIG. 13 is a rear end elevational view of the bucket tooth shown in FIG. 8;

FIG. 14 is a cross sectional view taken along line 14—14 of FIG. 9;

FIG. 15 is a front perspective view of a third embodiment of a bucket tooth, showing the new design;

FIG. 16 is a left side elevational view of the bucket tooth shown in FIG. 15; the right side being a mirror image;

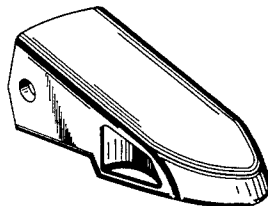
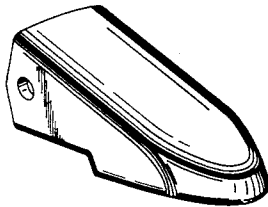
FIG. 17 is a top plan view of the bucket tooth shown in FIG. 15;

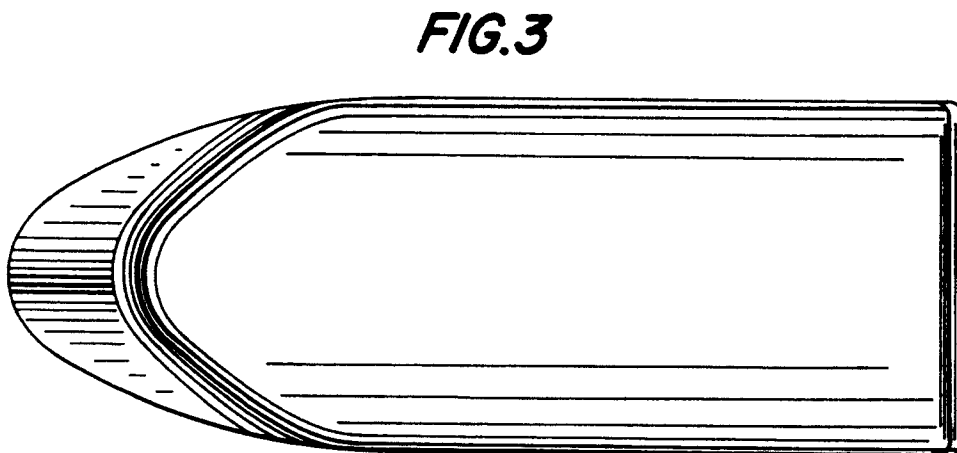
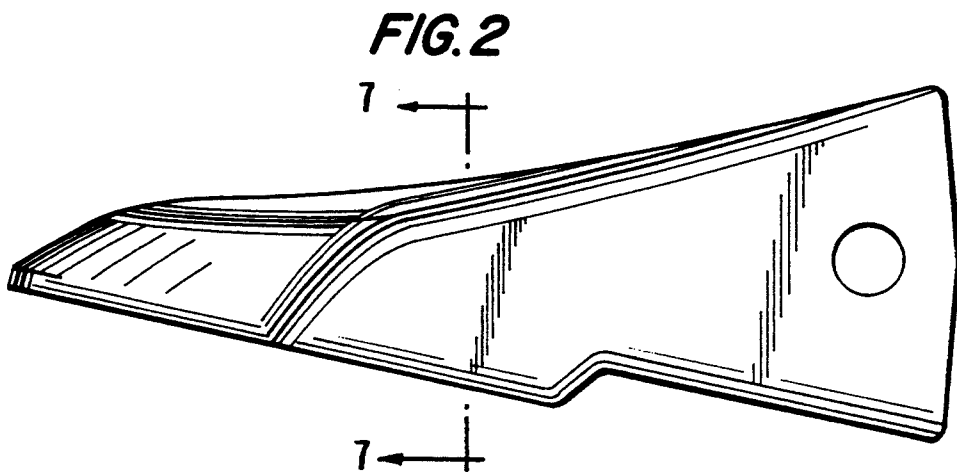
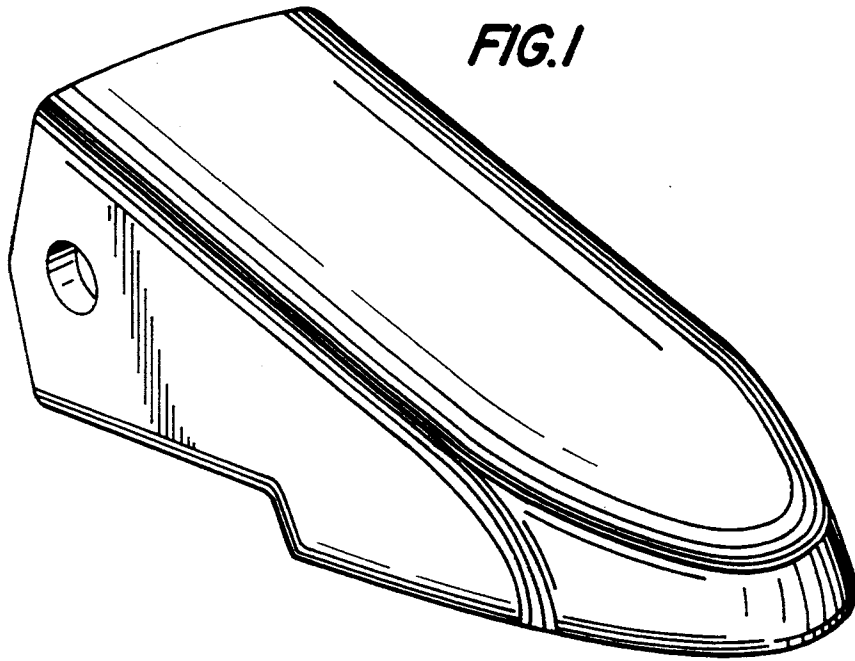
FIG. 18 is a bottom plan view of the bucket tooth shown in FIG. 15;

FIG. 19 is a front end elevational view of the bucket tooth shown in FIG. 15;

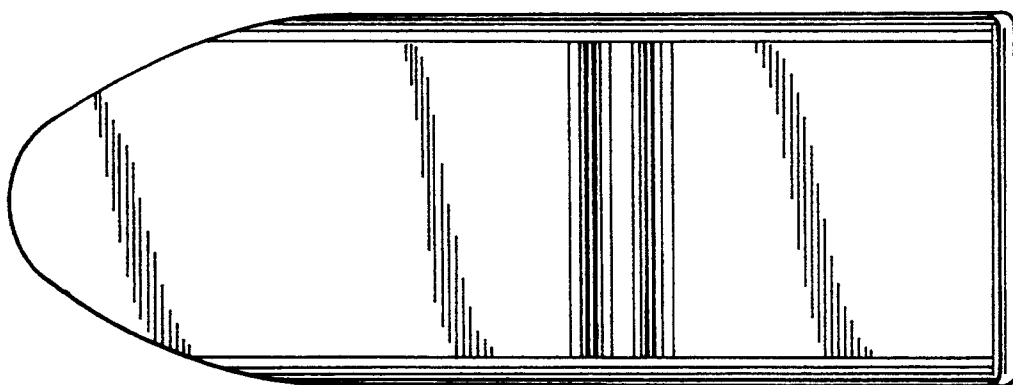
FIG. 20 is a rear end elevational view of the bucket tooth shown in FIG. 15; and,

FIG. 21 is a cross sectional view taken along line 21—21 of FIG. 16.

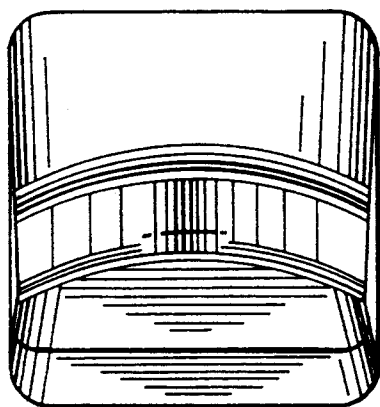




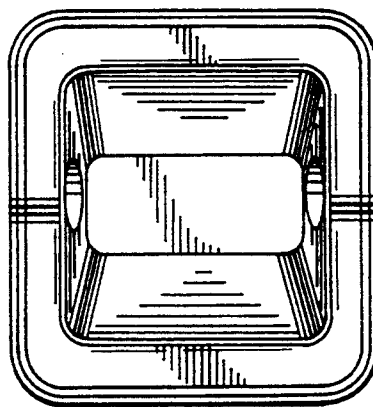
*FIG. 4*



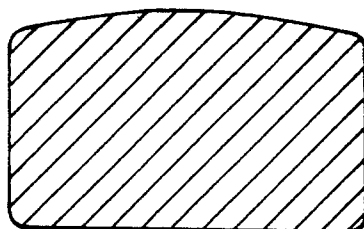
*FIG. 5*

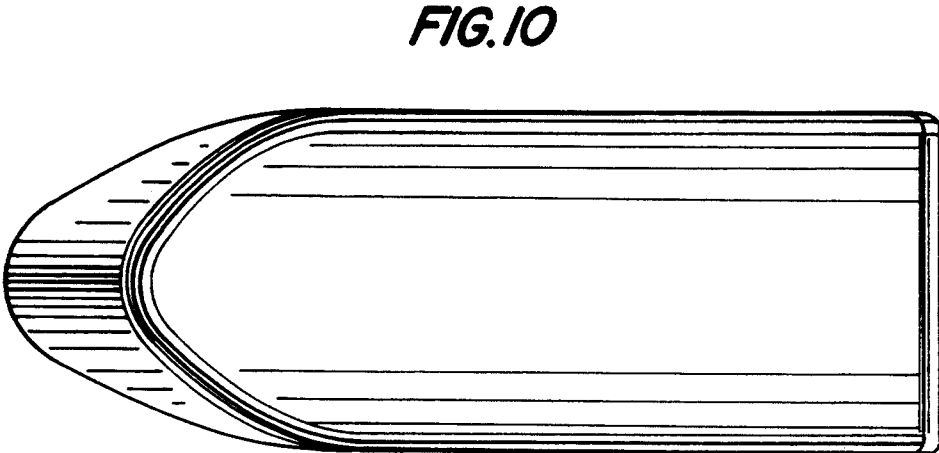
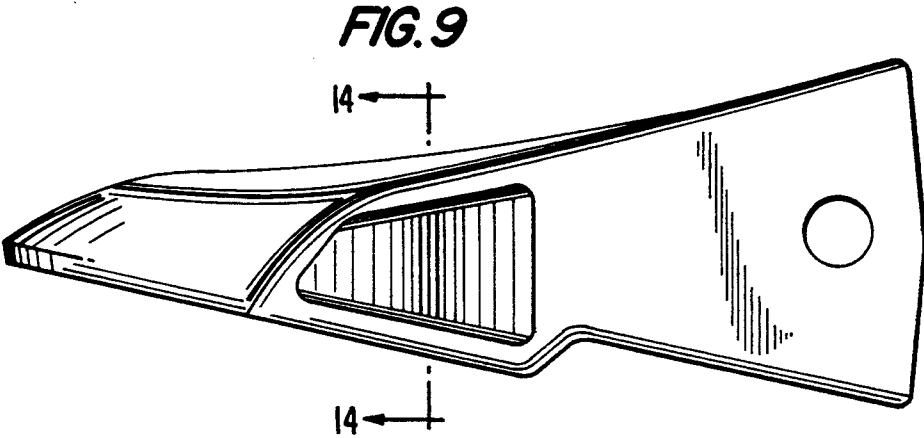
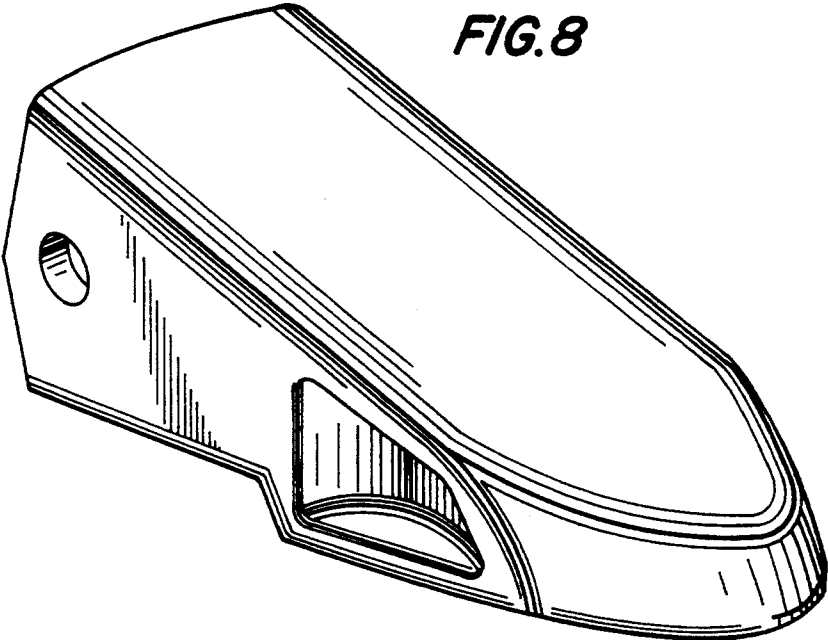


*FIG. 6*

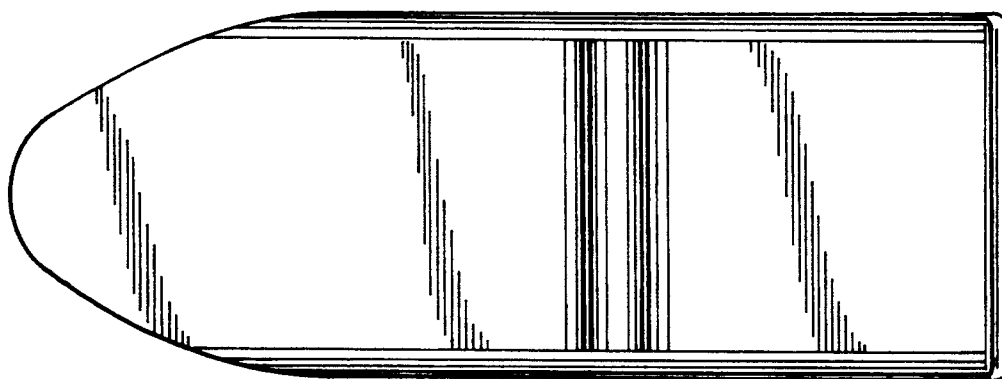


*FIG. 7*

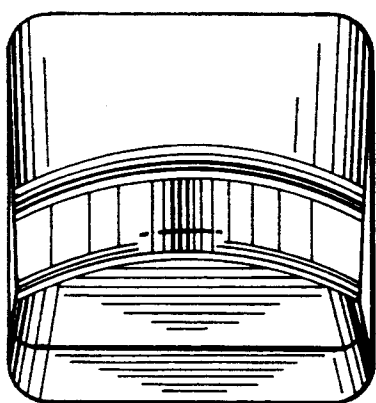




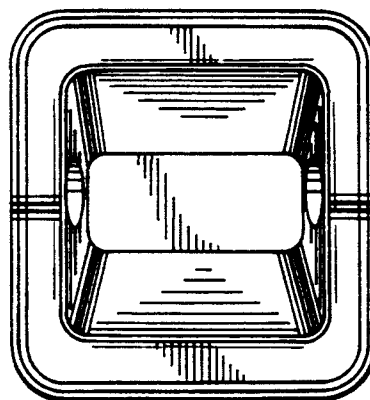
**FIG. 11**



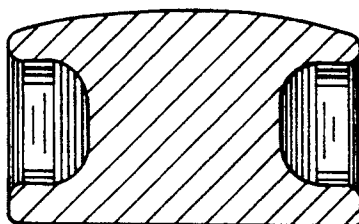
**FIG. 12**



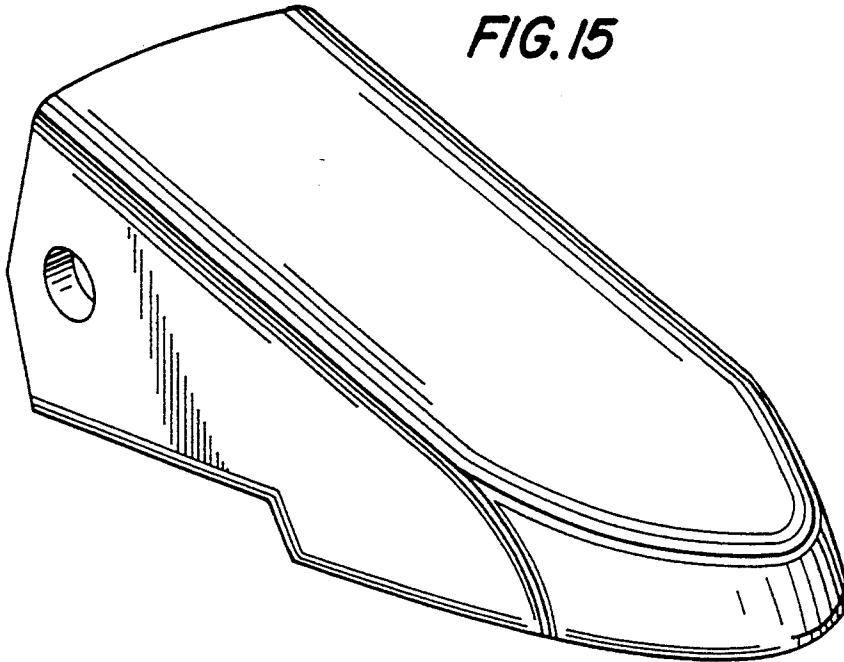
**FIG. 13**



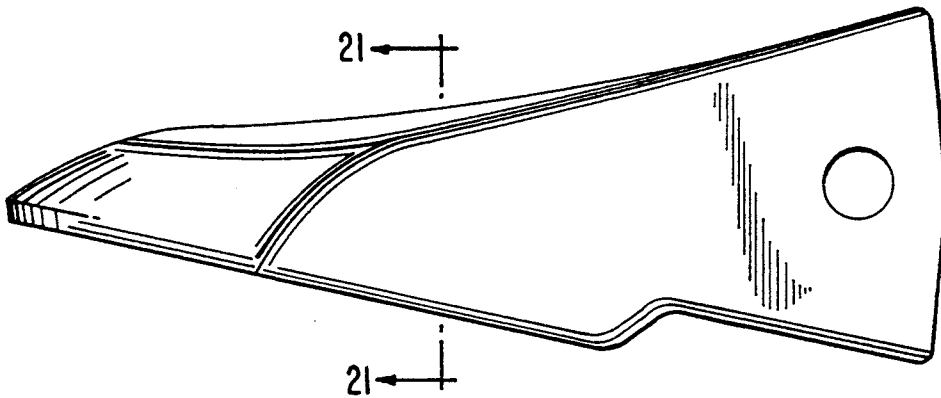
**FIG. 14**



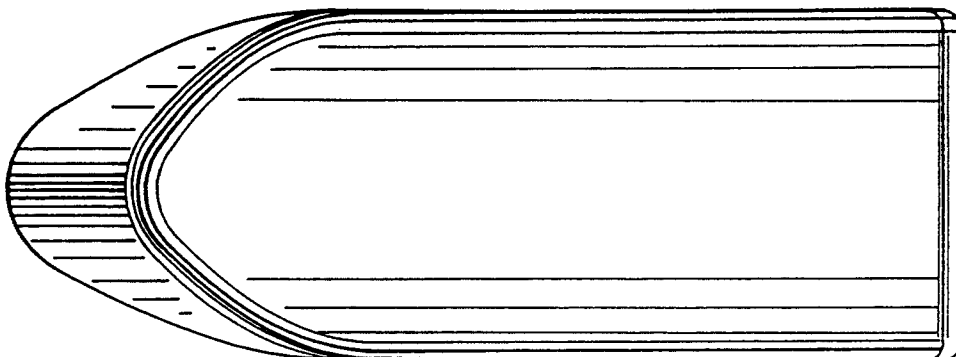
*FIG. 15*



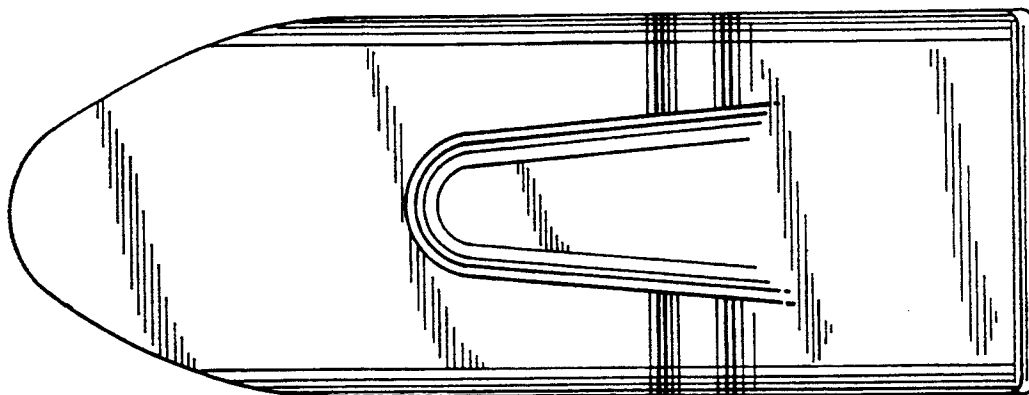
*FIG. 16*



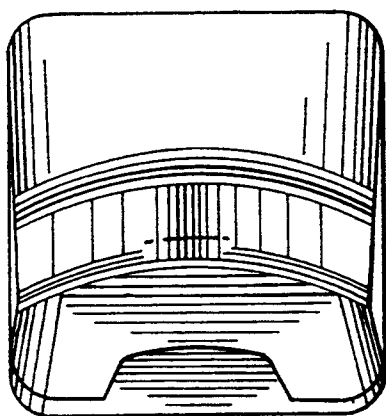
*FIG. 17*



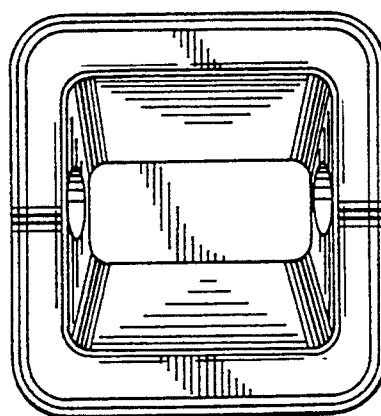
*FIG. 18*



*FIG. 19*



*FIG. 20*



*FIG. 21*

