

1

2

3

4

5

6

7

8 7

가

가

가

11 : 12 :

13 : 14 :

15 : 15a :

16 : 17 :

18 : 19 :

19a : 20 :

21 : G :

가

5) (3)

1

(5)
(7) 가
(G)

(1)

(3)

(7) (5)
2

(1)

(7)

(7) 가 가 (7) (G) (G) (G) (G)

(9)가 1 (G) (G) 가 2 가 (G) (G) 가 가

(7) 가 (7) 가 (G) (G) 가

가 (G) (7) 가

가 (G) (7)

가 (G) 가 (15)

(14) 가 (16) (16) (15)

3 4

3 (12) (13) (11) (12) (11)

(12) (13) (13) (14)가 (G)

(G) 가

(16) (14) (G)

(15) (11) (16) (12) (15)

4 (16) 가

(prepreg) 가

(16) (16) (16) 가

(16) 가 (16) 가

(16) (18) (17) (17) (18) (G) /
(Polyetherimide)

(18) 8 (18) (16) (G) 가 , 가
(16) (16)

(20) (16) (15) (19) (15) (19) (16) 4 5 (16)
(15) (19) (15a,19a) (15a,19a) (15) (19)
(16) 가 가

(16) (16) (21) (18) 가 (21)
(16)

(16) , 6 (14) 2 (15)
, 2 (15) (G) 가 1 , 3 (16)
가 (G) 가 가 (G)

, 6 7 (14)가 (G) 가 (16) (G)
(16)가 (G) (14) (G) (16)

, (G) 가 (16)

가 (16) 가 (15) 가 (G)
(G)

, (16) (17) ,

(16) (16) (15) (15a) (19) (19a) (2)
1) (20) (G) (16) (16) 가 (16)

(16) (16) (18) , (18)
, (16) (16) (16) (18)

(18) (16) (18) (18)

(18) , 8 (G)

(G)

(57)

1. (11) (12) (11) (12) (13)
 (14)가 (G) 가 (13)
 (G) (14) (15) 가 (16)

2. 1 (18) (16) (G) (18)

3. 1 (19a) (16) (20) (15) (15) (19) (15a) (19)

4. 3 (16) (21)

5. 1 (16)가

6. 1 (16)가

1

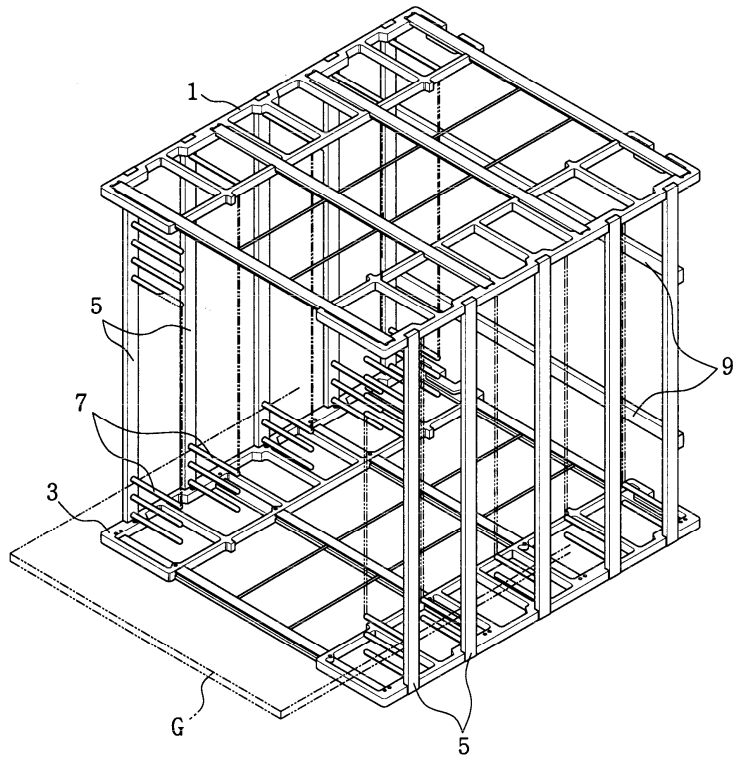

2

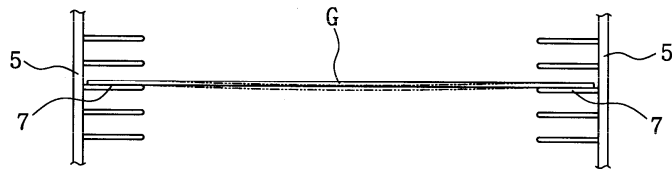

3

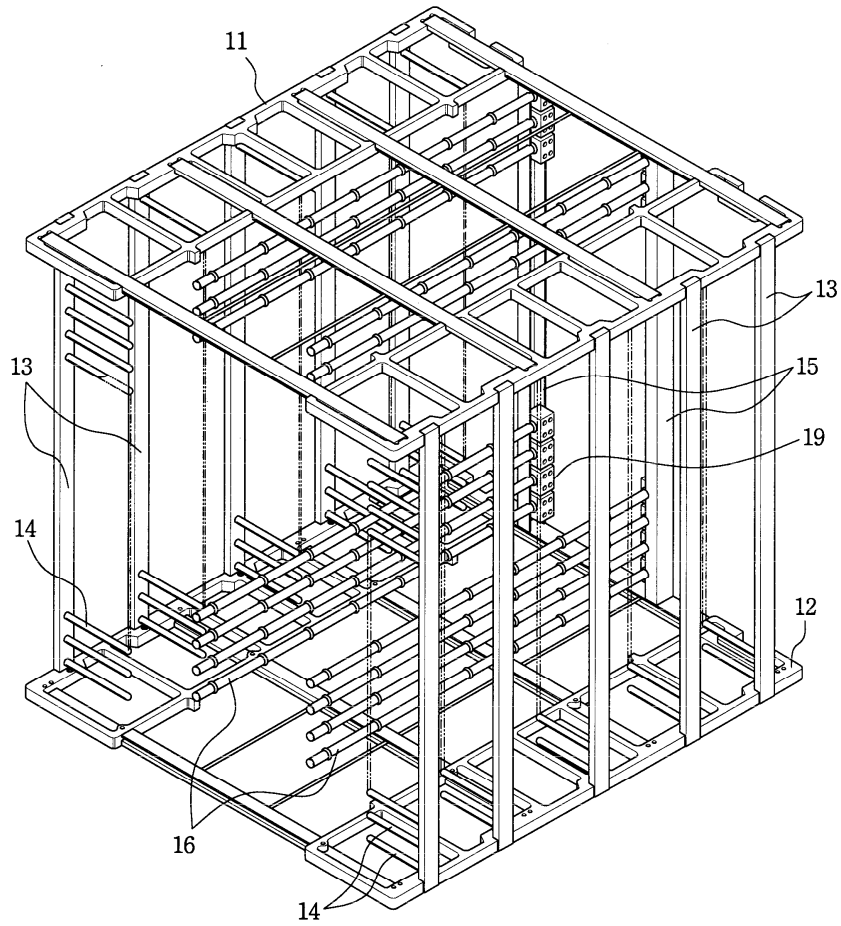

4

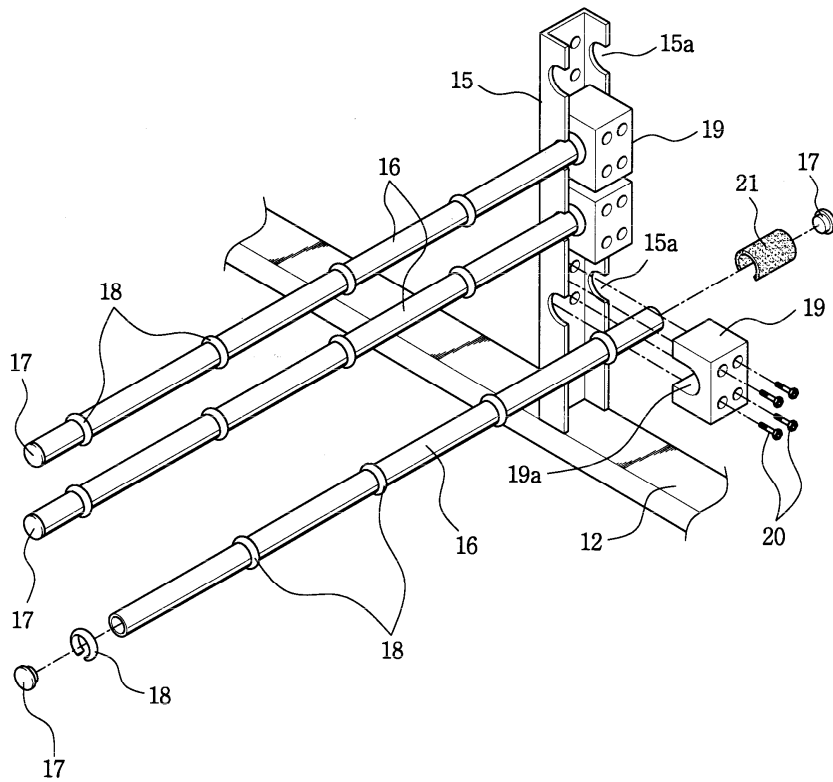

5

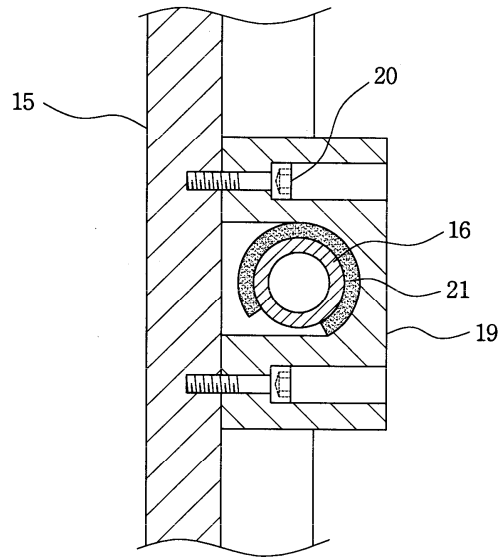

6

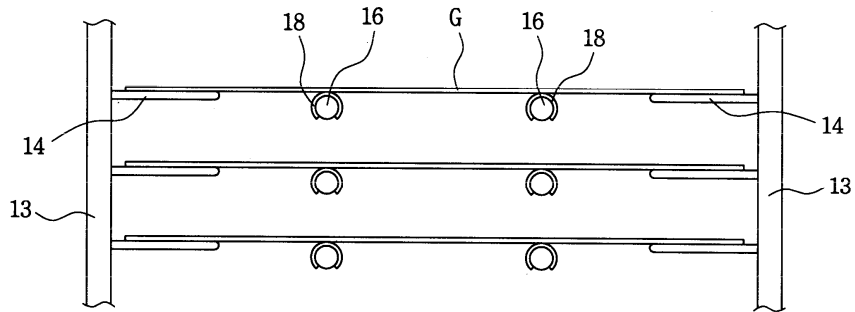

7

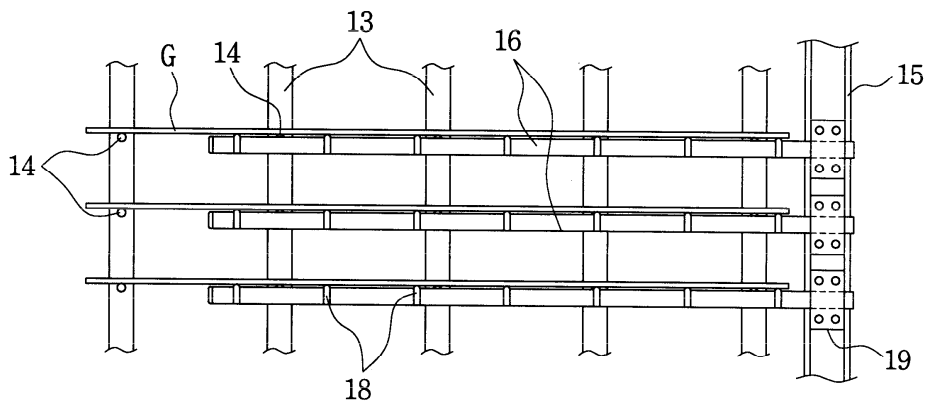

8

