

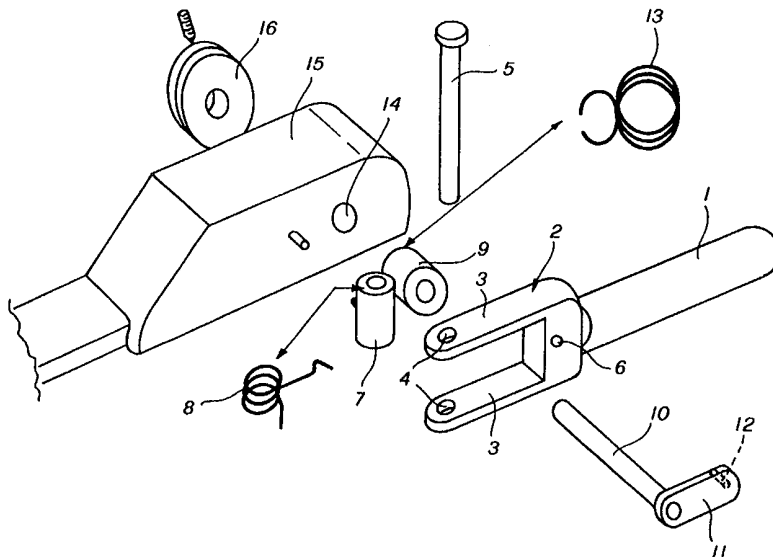

INTERNATIONAL APPLICATION PUBLISHED UNDER THE PATENT COOPERATION TREATY (PCT)

<p>(51) International Patent Classification⁶ : B60K 41/20, G05G 9/02</p>	<p>A1</p>	<p>(11) International Publication Number: WO 00/00362</p> <p>(43) International Publication Date: 6 January 2000 (06.01.00)</p>
<p>(21) International Application Number: PCT/IT99/00190</p> <p>(22) International Filing Date: 25 June 1999 (25.06.99)</p> <p>(30) Priority Data: RM98A000429 26 June 1998 (26.06.98) IT</p> <p>(71) Applicants (for all designated States except US): SISTEMA GUIDA 2000 S.R.L. [IT/IT]; Via Casalotti, 34, I-00166 Roma (IT). GUIDSIMPLEX S.N.C. DI GIANCARLO VENTURINI E C. [IT/IT]; Via del Podere S. Giusto, 29, I-00166 Roma (IT).</p> <p>(72) Inventor; and (75) Inventor/Applicant (for US only): SPINNATO, Dario [IT/IT]; Sistema Guida 2000 s.r.l., Via Casalotti, 34, I-00166 Roma (IT).</p> <p>(74) Agents: BANCHETTI, Marina et al.; Ing. Barzano' & Zanardo Roma S.p.A., Via Piemonte, 26, I-00187 Roma (IT).</p>		<p>(81) Designated States: AE, AL, AM, AT, AU, AZ, BA, BB, BG, BR, BY, CA, CH, CN, CU, CZ, DE, DK, EE, ES, FI, GB, GD, GE, GH, GM, HR, HU, ID, IL, IN, IS, JP, KE, KG, KP, KR, KZ, LC, LK, LR, LS, LT, LU, LV, MD, MG, MK, MN, MW, MX, NO, NZ, PL, PT, RO, RU, SD, SE, SG, SI, SK, SL, TJ, TM, TR, TT, UA, UG, US, UZ, VN, YU, ZA, ZW, ARIPO patent (GH, GM, KE, LS, MW, SD, SL, SZ, UG, ZW), Eurasian patent (AM, AZ, BY, KG, KZ, MD, RU, TJ, TM), European patent (AT, BE, CH, CY, DE, DK, ES, FI, FR, GB, GR, IE, IT, LU, MC, NL, PT, SE), OAPI patent (BF, BJ, CF, CG, CI, CM, GA, GN, GW, ML, MR, NE, SN, TD, TG).</p> <p>Published With international search report. Before the expiration of the time limit for amending the claims and to be republished in the event of the receipt of amendments. In English translation (filed in Italian).</p>

(54) Title: DEVICE FOR AUTOMATIC RELEASE OF ACCELERATOR DURING THE BRAKING ACTION



(57) Abstract

The invention relates to a device for the automatic release of the accelerator during the braking action, wherein a manual accelerator device is provided, means (16) interacting with said manual acceleration device and lever means (1) to control the acceleration and the braking, said acceleration and braking actions occurring according two substantially perpendicular directions, said device comprising integral coupling means (10) of said interaction means (16) with said manual acceleration device, releasable coupling means (11, 12), integral with said integral coupling means (10) and releasably connectable with said lever means (1), elastic means (8) hindering the releasing between said releasable means (11, 12) and said control lever means (1), and return elastic means (13) to return the acceleration device in a neutral position.

FOR THE PURPOSES OF INFORMATION ONLY

Codes used to identify States party to the PCT on the front pages of pamphlets publishing international applications under the PCT.

AL	Albania	ES	Spain	LS	Lesotho	SI	Slovenia
AM	Armenia	FI	Finland	LT	Lithuania	SK	Slovakia
AT	Austria	FR	France	LU	Luxembourg	SN	Senegal
AU	Australia	GA	Gabon	LV	Latvia	SZ	Swaziland
AZ	Azerbaijan	GB	United Kingdom	MC	Monaco	TD	Chad
BA	Bosnia and Herzegovina	GE	Georgia	MD	Republic of Moldova	TG	Togo
BB	Barbados	GH	Ghana	MG	Madagascar	TJ	Tajikistan
BE	Belgium	GN	Guinea	MK	The former Yugoslav Republic of Macedonia	TM	Turkmenistan
BF	Burkina Faso	GR	Greece	ML	Mali	TR	Turkey
BG	Bulgaria	HU	Hungary	MN	Mongolia	TT	Trinidad and Tobago
BJ	Benin	IE	Ireland	MR	Mauritania	UA	Ukraine
BR	Brazil	IL	Israel	MW	Malawi	UG	Uganda
BY	Belarus	IS	Iceland	MX	Mexico	US	United States of America
CA	Canada	IT	Italy	NE	Niger	UZ	Uzbekistan
CF	Central African Republic	JP	Japan	NL	Netherlands	VN	Viet Nam
CG	Congo	KE	Kenya	NO	Norway	YU	Yugoslavia
CH	Switzerland	KG	Kyrgyzstan	NZ	New Zealand	ZW	Zimbabwe
CI	Côte d'Ivoire	KP	Democratic People's Republic of Korea	PL	Poland		
CM	Cameroon	KR	Republic of Korea	PT	Portugal		
CN	China	KZ	Kazakistan	RO	Romania		
CU	Cuba	LC	Saint Lucia	RU	Russian Federation		
CZ	Czech Republic	LI	Liechtenstein	SD	Sudan		
DE	Germany	LK	Sri Lanka	SE	Sweden		
DK	Denmark	LR	Liberia	SG	Singapore		
EE	Estonia						

DEVICE FOR AUTOMATIC RELEASE OF ACCELERATOR DURING THE BRAKING ACTION

5 The present invention relates to a device for automatic release of the accelerator during the braking action.

More specifically, the invention relates to a device of the above kind, particularly employable in the automotive field, that allows to avoid any risk deriving from the prosecution of the acceleration action during the braking.

10 The problem of automatically releasing the accelerator during the braking phase is very important in many technical fields, but it is particularly important in the apparatuses to allow the driving to disabled persons.

15 At present, acceleration and braking devices for disabled persons are known, comprised of a pivoted lever under the steering member of the motor vehicle, or on the floor of the same, and provided with a handle of the motorcycle kind.

20 However, said devices does not allow the automatic annulment of the acceleration in case of braking. In fact, in case the acceleration handle is not manually, completely or partially, reset, as it can occur in case of emergency manoeuvring, an unavoidable and dangerous interference occurs between the two actions, and consequently the braking action is made inefficacy by the acceleration still active.

25 Main object of the present invention is that of solving the above mentioned drawbacks, suggesting a technical solution allowing to make the acceleration and braking action independent.

Another object of the present invention is that of obviating to the possible interference during the vehicle guide between the acceleration and braking actions.

30 It is therefore specific object of the present invention a device for the automatic release of the accelerator during the braking action, wherein a manual accelerator device is provided, means interacting with said manual acceleration device and lever means to control the acceleration and the braking, said acceleration and braking actions
35 occurring according two substantially perpendicular directions, said device comprising integral coupling means of said interaction means with said manual acceleration device, releasable coupling means, integral with said integral coupling means and releasably connectable with said lever

means, elastic means hindering the releasing between said releasable means and said control lever means, and return elastic means to return the acceleration device in a neutral position.

5 According to a preferred embodiment of the device according to the invention, said means for integral coupling with said interaction means can be comprised of a pin passing through a hole realised in a body of said acceleration device, and integral with said interaction means, said pin having on the other end a plate releasably coupled with said lever means.

10 Preferably, according to the invention, said control lever means provide on the back part a two arm fork, at the ends of said arms being provided means with said hindering elastic means.

Furthermore, according to the invention, a relief can be provided on said plate, coupling with a blind hole realised on said control lever means, to release or not the coupling during the braking action.

15 Still according to the invention, an adjustable stop can be provided, allowing the releasing of said control lever means and releasable coupling means.

20 Always according to the invention, said return elastic means can be comprised of the same return elastic means provided by the acceleration device, or of spring means provided on said releasable coupling means.

Preferably, according to the invention, a cruise control device can be provided.

25 Particularly, said cruise control device can provide a plate, provided behind the accelerator device, and provided with means for fixing the acceleration position and means for interaction with manual acceleration and braking means.

30 The present invention will be now described, for illustrative but not limitative purposes, according to its preferred embodiments, with particular reference to the figures of the enclosed drawings, wherein:

Figure 1 is a schematic perspective view of a device according to the invention;

figure 2 is an exploded view of the device of figure 1; and

35 figure 3 is an exploded view of a second embodiment of a device according to the invention.

Making reference to figures 1 and 2 of the enclosed drawings, the device according to the invention is mounted on an acceleration and

braking assembly to allow the driving to disabled persons, in this case particularly, even if not exclusively, to tetraplegic persons.

In figures 1 and 2, it is shown a lever 1, upon which the driver acts both to accelerate and brake, respectively according to the directions indicated by arrows A and B.

Said lever 1 ends with a fork 2, provided, on the free ends of its arms 3, with through holes 4, wherein the pin 5 is coupled.

On the body of the fork 2, laterally outwardly with respect to the device, observing the same in the figure, it is further provided a blind hole 6, the function of which will be described in greater detail in the following.

On the pin 5 a sleeve 7, as well as hindering spring 8 are provided.

Perpendicularly with respect to the fork 2, between the two arms 3, a further centrally holed sleeve 9 is placed, through which the pin 10 passes, said pin 10 being externally provided with a plate 11, said plate having a relief 12 coupling with said blind hole 6.

Coaxially to the sleeve 9 a hindering spring 13 is placed, hindering the motion of the lever 1 according to the arrow A.

Pin 10 passes through a hole 14 of the body 15 to couple with a pulley 16 of the acceleration device mounted on the vehicle to allow the driving to disabled persons, and which is not part of the invention, and for this reason it is not described in greater detail.

Making particularly reference to figure 1, in the following the operation of the device according to the invention will be explained.

During acceleration, the driver acts on the lever 1, according to the direction of arrow A. Relief 12 is engaged within the blind hole 6, so that said action involves the rotation of all the lever 1 – fork 2 – pin 10 assembly, along with plate 11 – pulley 16, with respect to the body 15, thus acting on the cable 17 of the acceleration device (not shown).

In case of braking, driver acts on the lever 1 according to arrow B, so that the releasing of the relief 12 from the blind hole 6 is obtained. Now, the action of the spring 13 instantaneously brings back the pin 10 – plate 11 – pulley 16 assembly in the original position, thus eliminating any action on the acceleration device of the motor vehicle and preventing any possibility of occurring accidents like those described in the introductory portion of the description.

On the inner part of the fork 2 a stop (not shown in the figure) is shown, determining the lever 1 and fork 2 run, necessary to determine the release of the acceleration action before prosecuting the braking action.

5 Once the braking action is finished, spring 8 will couple again relief 12 and blind hole, now ready to start again the use of the device.

Obviously, as already mentioned, the device according to the invention can be realised with modifications which are included in the normal knowledge of one skilled in the art.

10 For example, pin 10 and plate 11 could be provided on the other side of the body 15, beyond the pulley 16 connecting with the acceleration device.

Furthermore, the same pulley 16 could be replaced by different means for interaction with the acceleration device.

15 Coming now to make reference to figure 3, a second embodiment of the device according to the invention is shown. The solution shown in figure 3 is substantially equal to the preceding one, so that corresponding parts will be indicated by the same references. Substantially, the main difference is the fact that it is realised for a left-
20 hander person, and that it provides a cruise control device, that could also be provided in the previous embodiment.

Device shown in figure 3 provides a lever 1, upon which the driver acts both to accelerate and brake.

25 Said lever 1 ends with an element 2, provided with a U shaped portion provided, on the free ends of its arms 3, with through holes 4, wherein the pin 5 is coupled.

On the body of the element 2 a peg 6' is provided, the function of which will be described in greater detail in the following.

30 Pin 5 passes within an element 22, shown in the enlarged particular of the figure, providing two perpendicular sleeves, respectively 7 and 9, and a spring 8.

Pin 10 passes through the sleeve 9. Externally to said pin 10 a plate 11 is provided, said plate having a notch 12' coupling with said peg 6'.

35 Coaxially to the sleeve 9 a hindering spring 13 is placed, hindering the motion of the lever 1 during acceleration.

Pin 10 passes through a hole 14 realised in the body 15 to couple with a plate 16' of the acceleration device mounted on the vehicle

to allow the driving to disabled persons, and which is not part of the invention, and for this reason it is not described in greater detail.

On said body 15 it is further mounted the "cruise control" device, comprised of a plate 17, provided on one side with a pin 18 ending with a spiral spring 19, and that enters within a hole (not shown) realised in the body 15, and on the other side ending with a peg 20, that will couple with one of a plurality of circumferential holes (not shown), realised on said element 16'.

Laterally, a knob 21 is provided, coupled with said pin 18 and slidable along a slot (not shown), realised in said body 15.

If the driver wishes to use the cruise control device, he will act on the knob 21, returning the plate 17 and thus inserting the peg 20 in the suitable hole of said plurality of circumferential holes.

In any moment, in case of further action on the lever 1, either to brake or to accelerate, the cruise control device will be released.

The present invention has been described for illustrative but not limitative purposes, according to its preferred embodiments, but it is to be understood that modifications and/or changes can be introduced by those skilled in the art without departing from the relevant scope as defined in the enclosed claims.

6
CLAIMS

1. Device for automatic release of the accelerator during the
braking action, wherein a manual accelerator device is provided, means
5 interacting with said manual acceleration device and lever means to
control the acceleration and the braking, said acceleration and braking
actions occurring according two substantially perpendicular directions,
said device being characterised in that it comprises integral coupling
means of said interaction means with said manual acceleration device,
10 releasable coupling means, integral with said integral coupling means and
releasably connectable with said lever means, elastic means hindering the
releasing between said releasable means and said control lever means,
and return elastic means to return the acceleration device in a neutral
position.

15 2. Device according to claim 1, characterised in that said means
for integral coupling with said interaction means are comprised of a pin
passing through a hole realised in a body of said acceleration device, and
integral with said interaction means, said pin having on the other end a
plate releasably coupled with said lever means.

20 3. Device according to one of the preceding claims,
characterised in that said control lever means provide on the back part a
two arm fork, at the ends of said arms being provided means with said
hindering elastic means.

25 4. Device according to one of the preceding claims,
characterised in that a relief is provided on said plate, coupling with a blind
hole realised on said control lever means, to release or not the coupling
during the braking action.

30 5. Device according to one of the preceding claims,
characterised in that an adjustable stop is provided, allowing the releasing
of said control lever means and releasable coupling means.

6. Device according to one of the preceding claims,
characterised in that said return elastic means are comprised of the same
return elastic means provided by the acceleration device, or of spring
means provided on said releasable coupling means.

35 7. Device according to one of the preceding claims,
characterised in that a cruise control device is provided.

7

8. Device according to claim 7, characterised in that said cruise control device provides a plate, provided behind the accelerator device, and provided with means for fixing the acceleration position and means for interaction with manual acceleration and braking means.

5 9. Device according to each one of the preceding claims, substantially as illustrated and described.

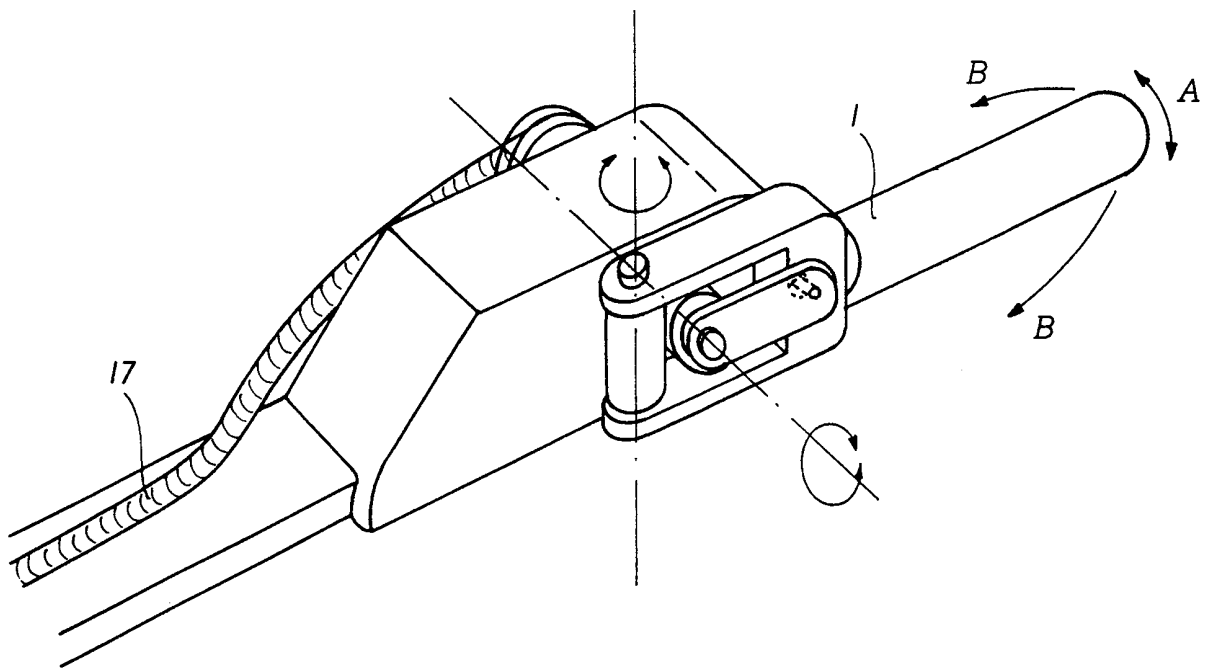

FIG. 1

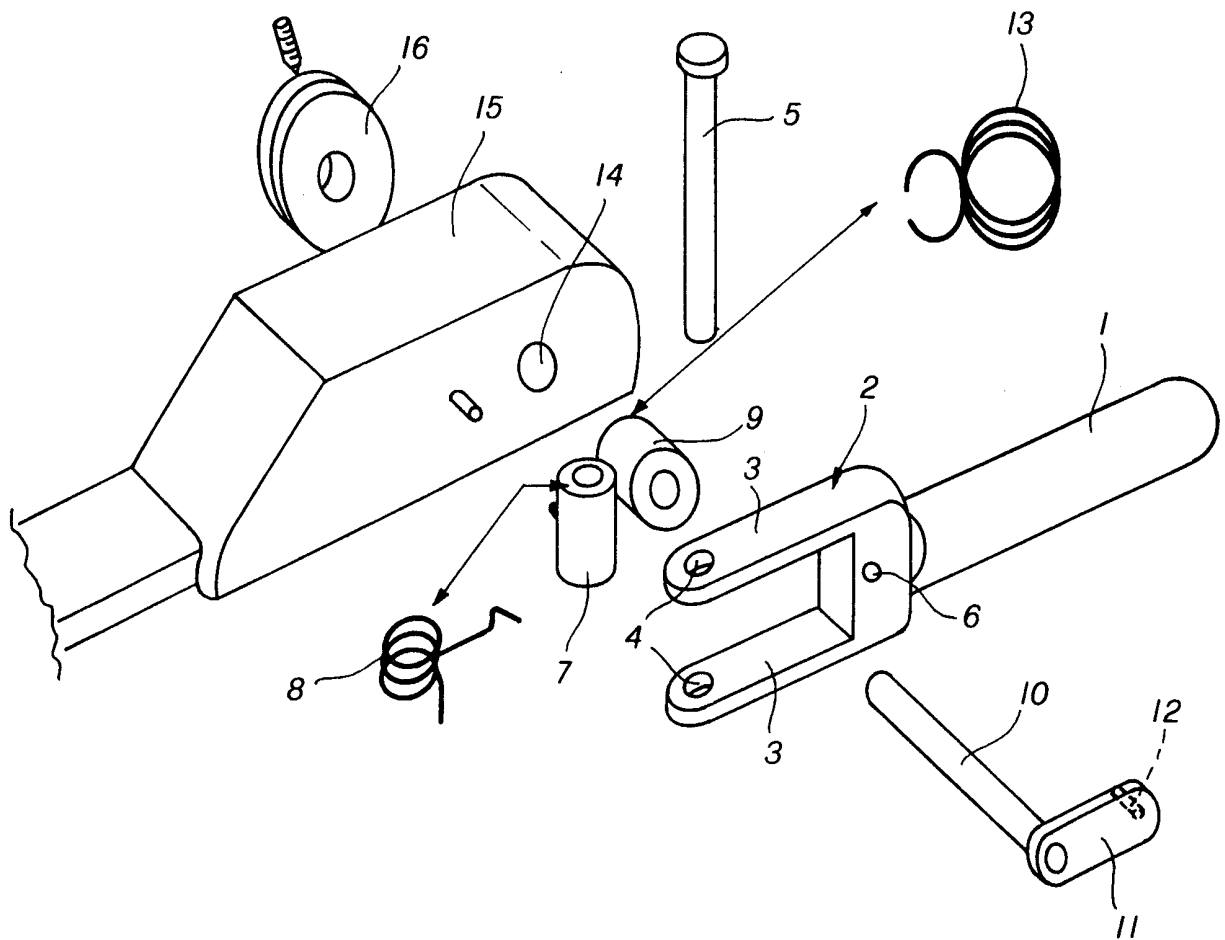
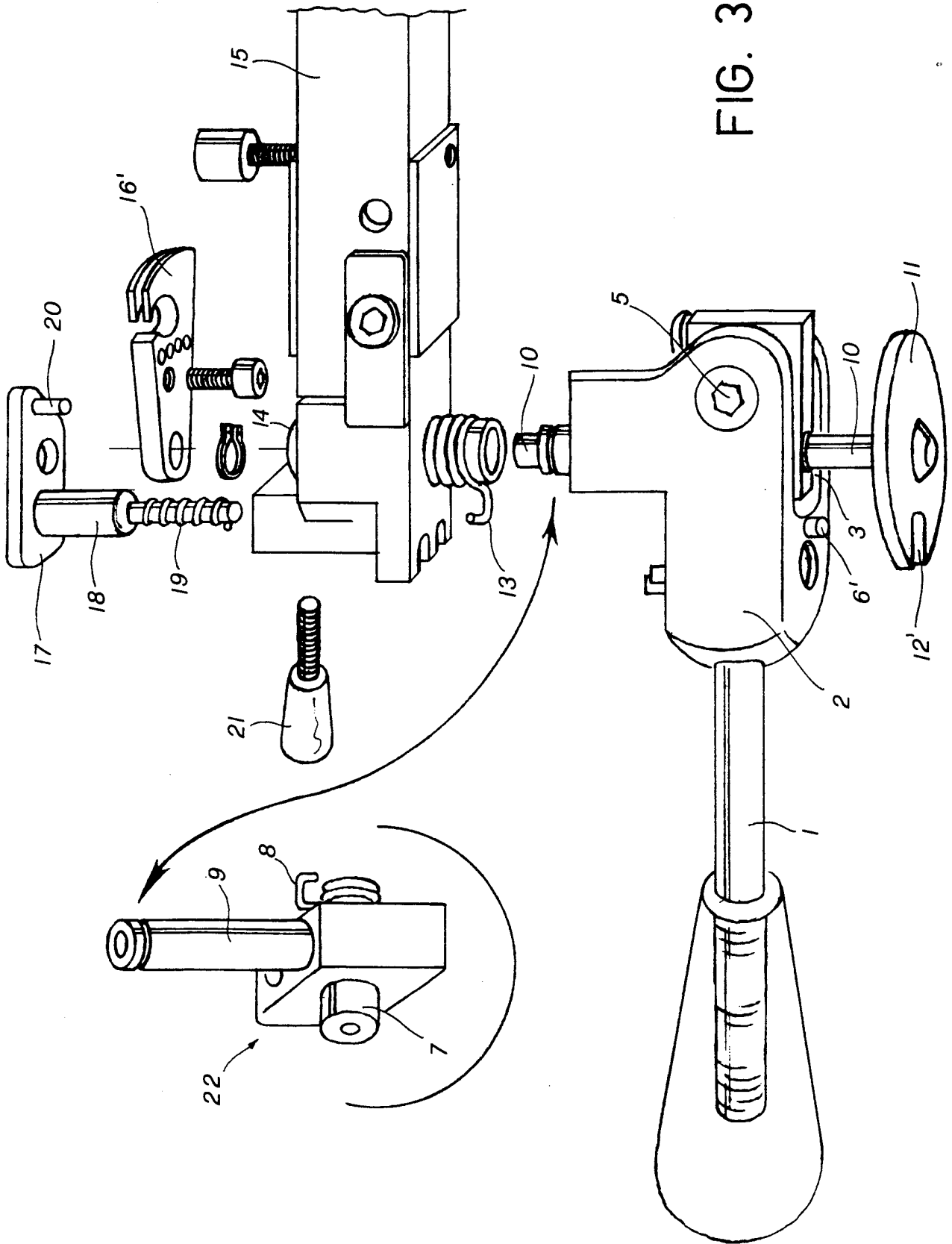

FIG. 2



INTERNATIONAL SEARCH REPORT

International Application No

PCT/IT 99/00190

A. CLASSIFICATION OF SUBJECT MATTER
 IPC 6 B60K41/20 G05G9/02

According to International Patent Classification (IPC) or to both national classification and IPC

B. FIELDS SEARCHED

Minimum documentation searched (classification system followed by classification symbols)

IPC 6 B60K G05G

Documentation searched other than minimum documentation to the extent that such documents are included in the fields searched

Electronic data base consulted during the international search (name of data base and, where practical, search terms used)

C. DOCUMENTS CONSIDERED TO BE RELEVANT

Category *	Citation of document, with indication, where appropriate, of the relevant passages	Relevant to claim No.
A	EP 0 297 671 A (VAN DER VLIET, T.T.) 4 January 1989 (1989-01-04) abstract	1-9
A	---	
A	EP 0 139 082 A (FORD MOTOR CO., LTD.) 2 May 1985 (1985-05-02) abstract	1-9
A	---	
A	AU 663 460 A (MAY, M.C.) 5 October 1995 (1995-10-05) abstract	1-9
A	---	
A	GB 2 290 509 A (WEBBER, J.) 3 January 1996 (1996-01-03) page 4, line 20 -page 5, line 5	1-9

	-/--	

Further documents are listed in the continuation of box C.

Patent family members are listed in annex.

* Special categories of cited documents :

- *A* document defining the general state of the art which is not considered to be of particular relevance
- *E* earlier document but published on or after the international filing date
- *L* document which may throw doubts on priority claim(s) or which is cited to establish the publication date of another citation or other special reason (as specified)
- *O* document referring to an oral disclosure, use, exhibition or other means
- *P* document published prior to the international filing date but later than the priority date claimed

- *T* later document published after the international filing date or priority date and not in conflict with the application but cited to understand the principle or theory underlying the invention
- *X* document of particular relevance; the claimed invention cannot be considered novel or cannot be considered to involve an inventive step when the document is taken alone
- *Y* document of particular relevance; the claimed invention cannot be considered to involve an inventive step when the document is combined with one or more other such documents, such combination being obvious to a person skilled in the art.
- *Z* document member of the same patent family

Date of the actual completion of the international search

8 October 1999

Date of mailing of the international search report

28 OCT 1999

Name and mailing address of the ISA

European Patent Office, P.B. 5818 Patentlaan 2
 NL - 2280 HV Rijswijk
 Tel. (+31-70) 340-2040, Tx. 31 651 epo nl,
 Fax: (+31-70) 340-3016

Authorized officer

Per-01of warnbo

INTERNATIONAL SEARCH REPORT

International Application No
PCT/IT 99/00190

C.(Continuation) DOCUMENTS CONSIDERED TO BE RELEVANT		
Category *	Citation of document, with indication, where appropriate, of the relevant passages	Relevant to claim No.
A	US 5 103 946 A (MASTERS ET AL.) 14 April 1992 (1992-04-14) column 1, line 38 - line 65 -----	1-9

INTERNATIONAL SEARCH REPORT

Information on patent family members

International application No.

PCT/IT 99/00190

Patent document cited in search report	Publication date	Patent family member(s)	Publication date
EP 0297671 A1	04/01/89	AT 80839 T DE 3874819 A NL 8701503 A US 4887701 A	15/10/92 29/10/92 16/01/89 19/12/89
EP 0139082 A2	02/05/85	DE 3333258 A,C	11/04/85
AU 663460 B	05/10/95	NONE	
GB 2290509 A	03/01/96	GB 9412576 D	00/00/00
US 5103946 A	14/04/92	CA 2053417 A,C	07/05/92