

(21) Application No 9114193.7

(22) Date of filing 01.07.1991

(71) Applicant  
Cego Limited

(Incorporated in the United Kingdom)

Western Road, Silver End, Witham, Essex,  
CM8 3QB, United Kingdom

(72) Inventor  
Melvin John Hutton

(74) Agent and/or Address for Service  
Mathisen Macara & Co  
The Coach House, 6-8 Swakeleys Road,  
Ickenham, Uxbridge, Middlesex, UB10 8BZ,  
United Kingdom

(51) INT CL<sup>5</sup>  
E05B 13/10

(52) UK CL (Edition L)  
E2A AAR A101 A115 A160 A171 A190 A421

(56) Documents cited  
GB 2188671 A

(58) Field of search  
UK CL (Edition K) E2A AAR  
INT CL<sup>5</sup> E05B 13/10, E05C 3/04

(54) Locking handle

(57) A locking handle assembly for a door or window comprises a fixing plate (1), a handle (9) which is pivotally mounted on the fixing plate for movement between open and closed positions, and a catch (7) which automatically engages when the handle is moved into the closed position to prevent subsequent movement of the handle to an open position until the catch is released. The catch comprises a spring loaded plunger (7) housed in the fixing plate (1) and is arranged to project from the plate into a recess (18) in the handle (9) to prevent turning of the handle when it is in the closed position. The handle carries a spring loaded lockable push button (19) which can be depressed to push the plunger (7) out of the recess (18) to allow turning of the handle (9) a portion of the handle (9) engaging the plunger (7) to hold it depressed within the fixing plate (1) in all positions of the handle other than the closed position regardless of whether the push button (19) is depressed.

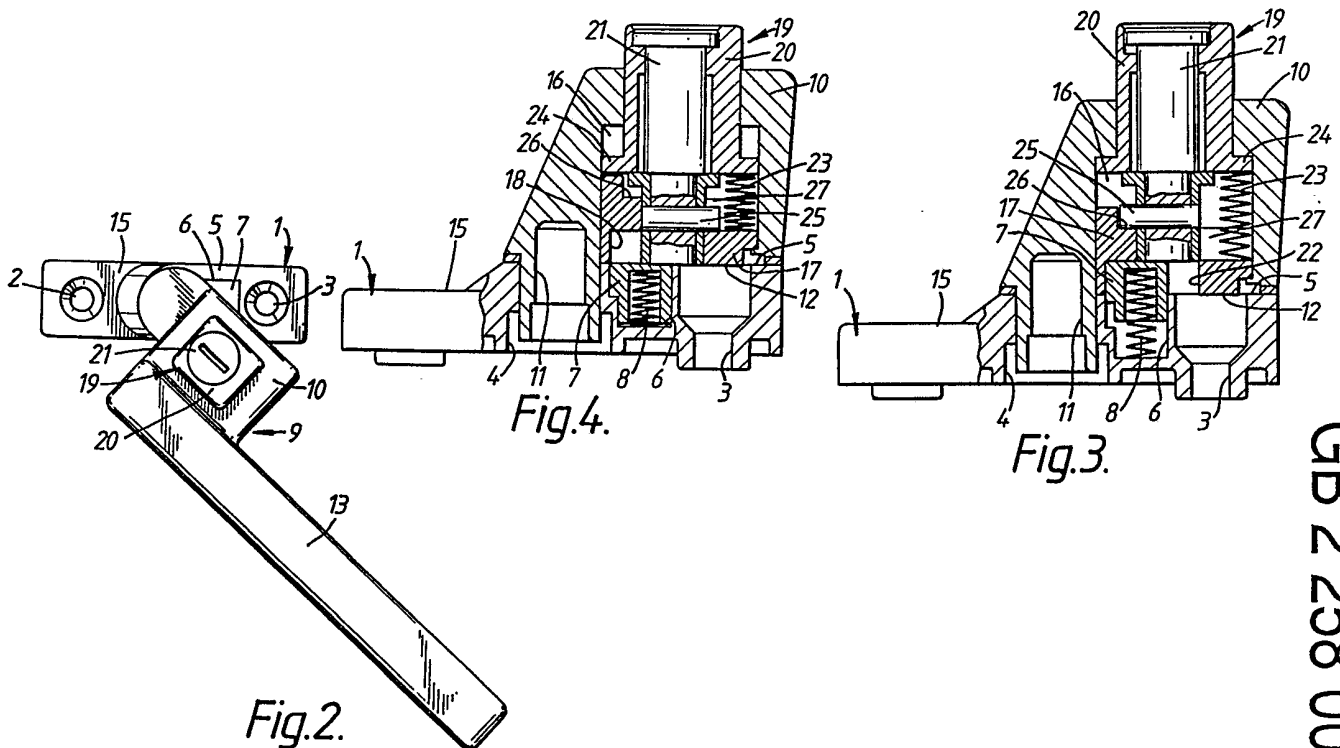

At least one drawing originally filed was informal and the print reproduced here is taken from a later filed formal copy.

The claims were filed later than the filing date within the period prescribed by Rule 25(1) of the Patents Rules 1990.

1/2

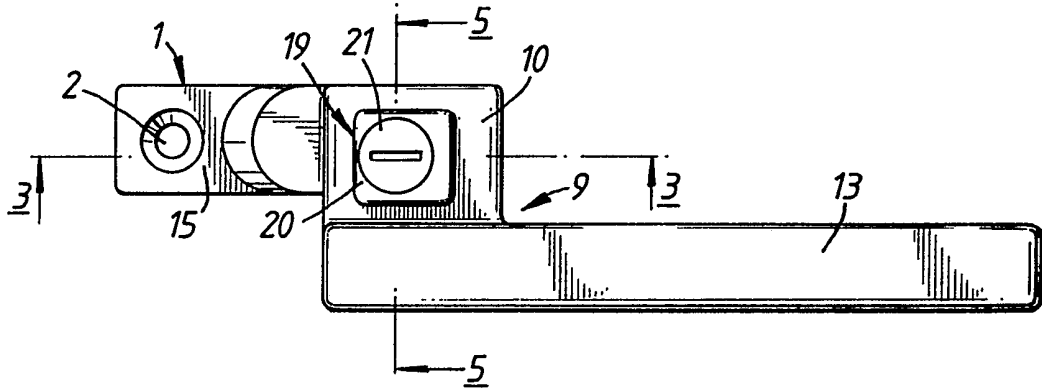

Fig. 1.

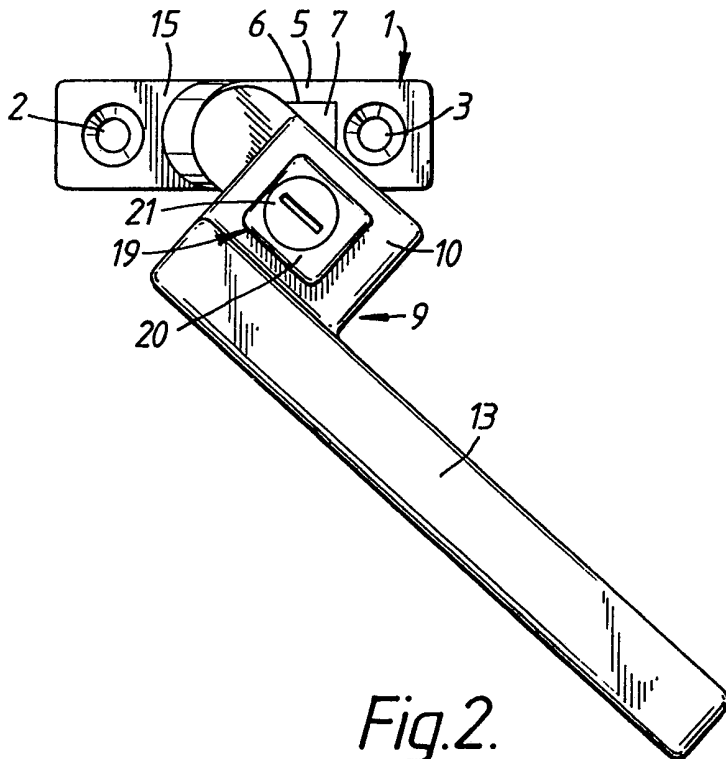

Fig. 2.

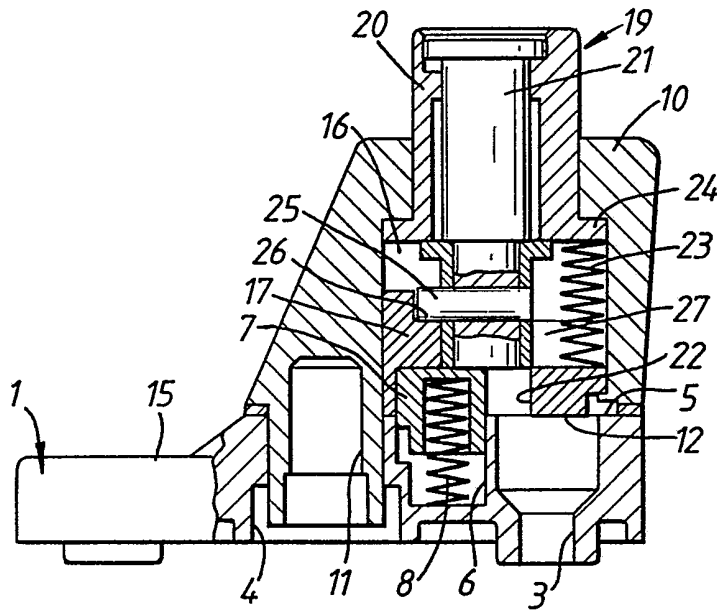

Fig. 3.

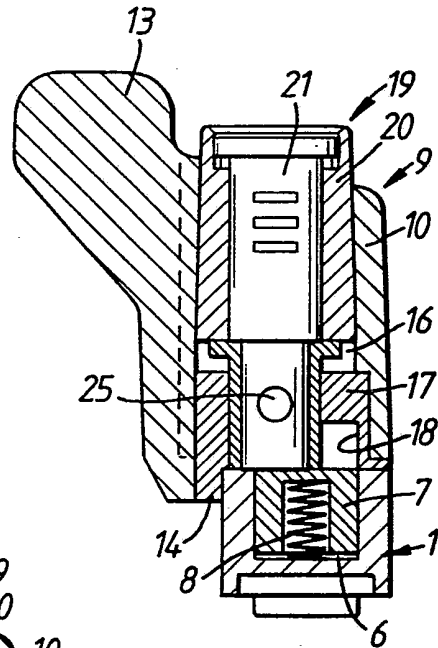

Fig. 5.

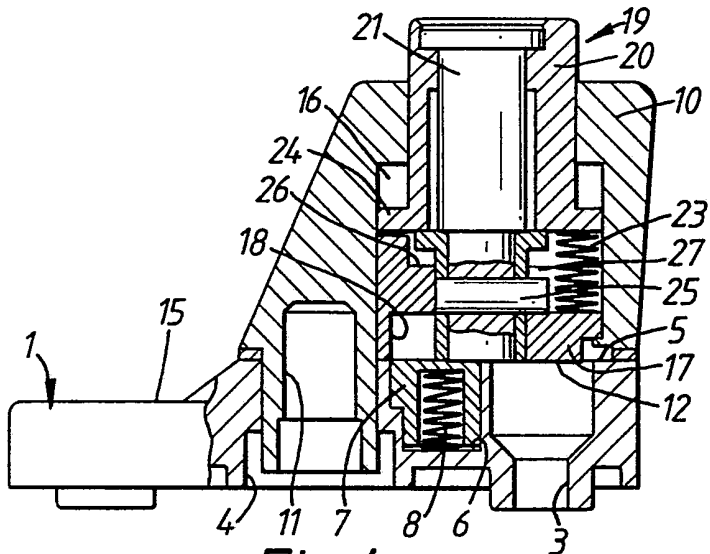

Fig. 4.

LOCKING HANDLE

The invention relates to a locking handle for a door or window, the locking handle being of the kind comprising a fixing plate, a handle which is pivotally mounted on the fixing plate for movement between open and closed positions, and a catch which automatically engages when the handle is moved into the closed position to prevent subsequent movement of the handle to an open position until the catch is released.

According to the invention, such a locking handle is characterised in that the catch comprises a spring loaded plunger which is housed in the fixing plate and is arranged to project from the plate into a recess in the handle to prevent turning of the handle when the handle is in the closed position, the handle carries a spring loaded push button which can be depressed to push the plunger out of the recess to allow turning of the handle from the closed position, and a portion of the handle engages the plunger to hold it depressed within the fixing plate in all positions of the handle other than the closed position whether or not the push button is depressed.

Preferably the portion of the handle which holds the

plunger depressed when the handle is out of the closed position comprises a face of the handle which surrounds the recess and overlies the fixing plate when the handle is closed.

In a preferred arrangement, the axes of the plunger and the push button are parallel, and are offset from each other when the handle is in the closed position so that the end of the push button which engages the plunger when the button is depressed only partially registers with the end of the plunger and has a portion disposed laterally outwards from the plunger. This arrangement facilitates manufacture of the locking handle assembly and also acts as a safeguard against over depression of the push button, since the portion of the button disposed laterally outwards from the plunger will abut the fixing plate around the plunger housing to prevent further depression when the plunger has been pushed fully out of the recess.

If desired, the push button may be provided with a locking cylinder which, when the button is not depressed, can be turned between a locked position in which depression of the button is prevented and an unlocked position in which depression of the button is permitted. This will permit dead locking of the handle in the closed position if so desired.

One embodiment of a locking handle in accordance with the invention will now be described, by way of example, with reference to the accompanying drawings, in which:-

Figure 1 is a plan view of the locking handle in its closed position;

Figure 2 is a plan view of the locking handle in an open position;

Figure 3 is a partial cross-section, to a larger scale, through the locking handle taken on the line 3-3 in Figure 1, showing the handle in the closed and locked position;

Figure 4 is a sectional view similar to that of Figure 3 but showing the handle in the closed but unlocked position with the push button depressed to allow the handle to be turned;

Figure 5 is a cross-section through the locking handle taken on the line 5-5 in Figure 1 with the handle in the condition shown in Figure 4.

The locking handle assembly comprises a fixing plate 1 of elongate rectangular shape having a recessed countersunk

screw hole 2,3 near each end, and a substantially central aperture 4 with its axis parallel to the axes of the screw holes 2,3. Also provided in the upper face 5 of the fixing plate 1, between the central aperture 4 and the screw hole 3, is a rectangular recess 6 housing a correspondingly shaped hollow plunger 7 which is biased by a coiled compression spring 8 so as to project out of the recess 6 beyond the plane of the upper face 5 of the fixing plate, but which can be depressed fully into the recess 6 against the action of the spring 8.

The locking handle assembly also comprises a handle 9 which is pivotally mounted on the fixing plate 1, the handle 9 having a body portion 10 provided with a boss 11 projecting from the underside 12 of the body portion and received rotatably in the aperture 4 of the fixing plate to pivotally mount the handle on the plate. The boss 11 is hollow for receiving a conventional square sectioned spindle (not shown), and conventional means (not shown), such as a circlip, is provided for preventing removal of the boss from the aperture 4. The handle 9 also includes a hand grip 13 which extends from the upper end of the body portion 10 at one side thereof in a direction substantially perpendicular to the pivot axis of the handle.

The handle 9 is pivotable from a closed position shown in Figures 1,4 and 5 in which the undersurface 12 of the handle body 10 overlies the upper surface 5 of the fixing plate 1 and the hand grip 13 lies substantially parallel to the longitudinal axis of the fixing plate, and an open position, for example as illustrated in Figure 2, in which the handle 9 is displaced angularly from the closed position about the pivot axis defined by the boss 11 in the bore 4. The body portion 10 of the handle 9 is provided with a stop 14 which projects from the lower face 12 at one side thereof (in this example the same side as the hand grip 13) and which abuts the near side of the fixing plate 1 as shown in Figure 5 when the handle is in the closed position so that the handle can only be opened in one direction. In the example illustrated, the handle 9 can be opened through approximately  $270^{\circ}$  until the stop 14 comes into engagement with the opposite side of the fixing plate 1, the upper portion of the fixing plate at its end adjacent the screw hole 2 being cut away as indicated at 15 to accommodate the passage of the stop 14 during such movement of the handle.

The body portion 10 of the handle is hollow to define an internal chamber 16 which is substantially closed at the underside 12 of the body portion by a moulded plastics



plug 17. The plug 17 in fact forms an interface between the underside 12 of the body portion 10 and the upper surface 5 of the fixing plate 1, and is formed with a substantially rectangular recess 18 positioned so that when the handle is in the closed position the recess will register over the recess 6 in the fixing plate 1 whereby the plunger 7 will be able to enter the recess 18 under the action of its biasing spring 8 in order to prevent the handle from being turned from the closed position towards an open position.

Also housed within the chamber 16 of the handle body portion 10 is a push button 19 having a hollow shell portion 20 of substantially rectangular cross-section which extends through a correspondingly shaped opening at the upper end of the body portion 10 to project above the upper surface thereof. The push button 19 also comprises a cylindrical core 21 in the form of a key operated locking cylinder which is retained axially within the shell 20 and has its lower end projecting beyond the lower end of the shell into a substantially cylindrical passage 22 which extends through the plug 17 and intersects the recess 18. The axes of the recess 18 and the locking cylinder 21 are parallel but diagonally offset from each other so that approximately one sector of the passage cross-section overlaps one quadrant of the

recess cross-section.

The push button 19 is biased to a raised position as shown in Figure 1 by means of a coiled compression spring 23 housed within the chamber 16 and acting between the plug 17 and the lower end of the push button shell 20, a radially outwardly directed flange 24 at the lower end of the shell serving to limit the upward movement of the push button by engagement with the top of the chamber 16. In this raised position of the push button 19, the lower end of the locking cylinder 21 is retracted within the passage 22 to a position approximately level with the upper end of the recess 18, and the locking cylinder can be rotated, upon insertion of a key, between a locked position in which a radially projecting pin 25 carried by the locking cylinder engages a surface 26 of the plug 17 to prevent depression of the push button 19, and a released position in which the pin 25 is aligned with an axial slot 27 in the plug 17 to permit the button 19 to be depressed.

Upon depression of the push button 19 against the action of the spring 23, the lower end of the locking cylinder 21 moves downwards through the passage 22 and, in the closed position of the handle, engages a portion of the upper surface of the plunger 7 projecting into the recess

18 and pushes it out of the recess 18 and down into the recess 6 in the fixing plate 1. When the push button 19 is fully depressed as shown in Figures 4 and 5, the lower end of the locking cylinder 21 of the push button 19 and the upper surface of the plunger 7 lie substantially in the plane of the interface between the handle 9 and the upper surface 5 of the fixing plate 1, thereby allowing the handle to be pivoted out of the closed position to an open position. As the handle moves away from the closed position, the recess 18 moves out of registry with the recess 6, thus bringing a portion of the lower face of the plug 17 into engagement with the upper surface of the plunger 7 to hold the plunger in the depressed position within the recess 6, and the arrangement of the assembly is such that the plunger will be held down in this manner by a portion of the undersurface of the plug in all angular positions of the handle other than the closed position. Thus, the handle may be moved freely in the open condition without needing to hold the push button 19 depressed, and on return to the closed position, the plunger 7 will automatically move into engagement with the recess 18 to prevent further turning of the handle until the push button is once again depressed to push the plunger out of the recess 18.

CLAIMS

1. A locking handle assembly for a door or window comprising a fixing plate, a handle which is pivotally mounted on the fixing plate for movement between open and closed positions, and a catch which automatically engages when the handle is moved into the closed position to prevent subsequent movement of the handle to an open position until the catch is released, the catch comprising a spring loaded plunger which is housed in the fixing plate and is arranged to project from the fixing plate into a recess in the handle to prevent turning of the handle when the handle is in the closed position, the handle carrying a spring loaded push button which can be depressed to push the plunger out of the recess to allow turning of the handle from the closed position, and a portion of the handle engaging the plunger to hold it depressed within the fixing plate in all positions of the handle other than the closed position whether or not the push button is depressed.

2. A locking handle assembly according to claim 1, in which the portion of the handle which holds the plunger depressed when the handle is out of the closed position comprises a face of the handle which surrounds the recess and overlies the fixing plate when the handle is closed.

3. A locking handle assembly according to claim 1 or claim 2, in which the axes of the plunger and the push button are parallel, and are offset from each other when the handle is in the closed position so that the end of the push button which engages the plunger when the button is depressed only partially registers with the end of the plunger and has a portion disposed laterally outwards from the plunger.

4. A locking handle assembly according to any one of the preceding claims, in which the push button is provided with a locking cylinder which, when the button is not depressed, can be turned between a locked position in which depression of the button is prevented and an unlocked position in which depression of the button is permitted.

5. A locking handle assembly according to any one of the preceding claims, in which the handle is provided with a stop which abuts one side of the fixing plate when the handle is in the closed position so that the handle can only be opened in one direction from the closed position.

6. A locking handle assembly according to claim 1, substantially as described with reference to the accompanying drawings.

**Patents Act 1977**  
**Examiner's report to the Comptroller under**  
**Section 17 (The Search Report)**

Application number

GB 9114193.7

**Relevant Technical fields**

- (i) UK Cl (Edition K ) E2A (AAR)
- (ii) Int Cl (Edition 5 ) E05B 13/10; E05C 3/04

**Search Examiner**

J D WILSON

**Date of Search**

16 OCTOBER 1992

**Databases (see over)**

- (i) UK Patent Office
- (ii)

Documents considered relevant following a search in respect of claims ALL

Category (see over)	Identity of document and relevant passages	Relevant to claim(s)
A	GB 2188671 A (REGENT LOCK) Whole document	1 at least



Category	Identity of document and relevant passages	Relevance to claim(s)

**Categories of documents**

**X:** Document indicating lack of novelty or of inventive step.

**Y:** Document indicating lack of inventive step if combined with one or more other documents of the same category.

**A:** Document indicating technological background and/or state of the art.

**P:** Document published on or after the declared priority date but before the filing date of the present application.

**E:** Patent document published on or after, but with priority date earlier than, the filing date of the present application.

**&:** Member of the same patent family, corresponding document.

**Databases:** The UK Patent Office database comprises classified collections of GB, EP, WO and US patent specifications as outlined periodically in the Official Journal (Patents). The on-line databases considered for search are also listed periodically in the Official Journal (Patents).