

July 12, 1927.

B. S. AIKMAN

1,635,524

METHOD OF AND MEANS FOR COOLING COMPRESSORS

Filed Nov. 9, 1925

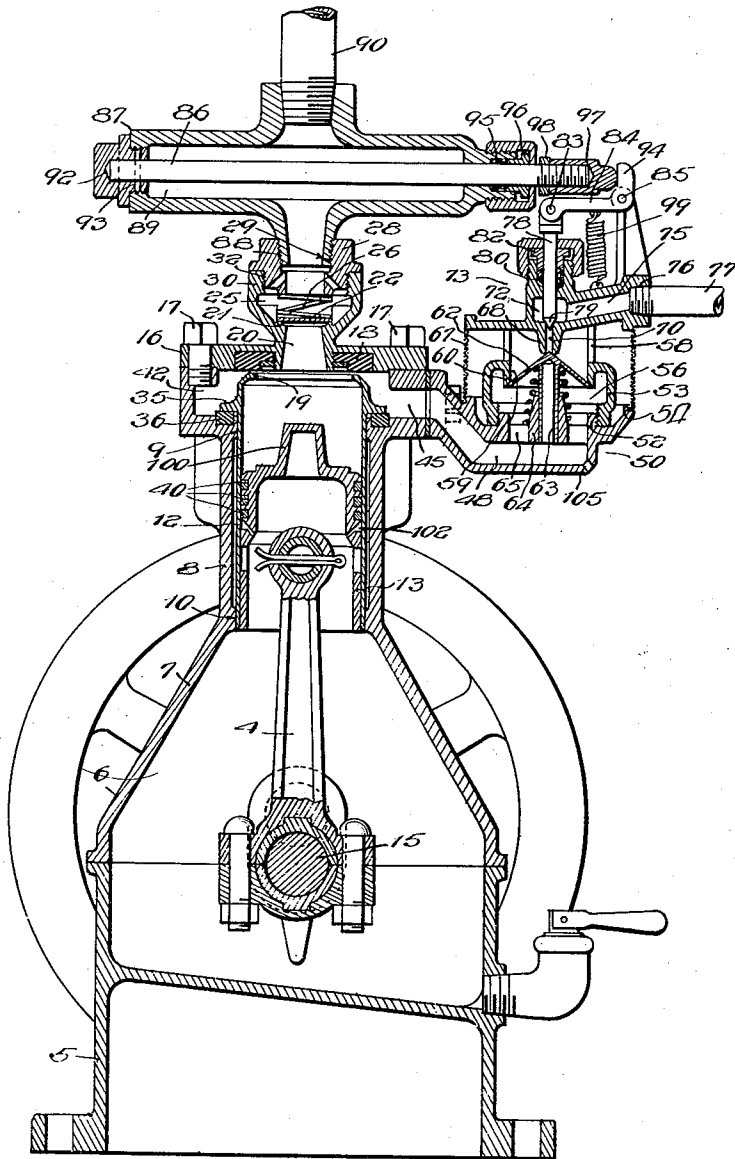

Witnesses:

William P. Kilroy
Harry C. White

Inventor:
Barton S. Aikman

Morgan Porter Sinner

K24

Att'y.

UNITED STATES PATENT OFFICE.

BURTON S. AIKMAN, OF MILWAUKEE, WISCONSIN, ASSIGNOR TO NATIONAL BRAKE AND ELECTRIC COMPANY, OF MILWAUKEE, WISCONSIN, A CORPORATION OF WISCONSIN.

METHOD OF AND MEANS FOR COOLING COMPRESSORS.

Application filed November 9, 1925. Serial No. 67,724.

This invention relates to an improved method of and means for cooling compressors and the like.

In the operation of fluid compressors and the like, cooling means are provided for preventing excessive temperatures which would otherwise impair lubrication and result in injury.

The water jacketing of a compressor now in common use is not entirely satisfactory. The heat that may be transmitted through the walls of the cylinder and head to the cooling fluid is limited by the thickness and by the conductivity of these walls, so that the temperature of the cooling medium does not rise to that of the discharged compressed fluid in the short time that the cooling fluid is in the jacket.

Considerable flow through the jacket must be maintained to prevent pocketing and local overheating, and due to practical limitations requiring considerable thickness or radial depth of the water jacket, it is impossible to transfer much heat to the liquid passing through the jacket. As a result, either a large circulation or a large water consumption are required.

Furthermore, as pointed out in my co-pending application, Serial No. 737,725, filed September 15, 1924, in certain compressors the cylinder head cannot readily be cooled in this manner.

It is the object of my present invention to provide an improved method of and means for cooling that will better serve the purpose for which a cooling system is intended, particularly for the cooling of compressors with relatively high rotative speeds of crank shaft, than can be accomplished where the conventional method of cooling by the conductance of the heat through the walls of the compression chamber is employed.

According to my present invention, I provide means for increasing the efficiency of the cooling system by subjecting the working fluid directly to the cooling liquid which may be water or any other liquid or medium found suitable or preferable for the purpose. This direct heat transfer permits maximum equalization of the temperatures of the working and cooling fluids so that a higher volumetric efficiency of the cooling system may be secured.

In my system of cooling, the cooling liq-

uid receives heat from the compressed gas not only to raise its temperature to that of the compressed gas (heat of the liquid), but the cooling liquid also receives sufficient heat from the compressed gas to vaporize the liquid (heat of vaporization). Hence, I use not only the absorption power of the liquid as such, but also its absorptive power in passing off into a vapor. This utilization of the heat of vaporization of the cooling liquid permits still further increasing the efficiency of the cooling medium and system.

By compressing the working fluid in the presence of the cooling medium, the working pressures of the compressor is utilized to raise the boiling point of the cooling liquid with a still further increase in the efficiency thereof.

I also provide means for controlling the cooling fluid supply to the compressor by the temperature of the compressed fluid. This controlling means may be regulated or adjusted so that no water or cooling liquid will enter the compression chamber until the temperature rise during the compression stroke is sufficiently high to completely evaporate that water that is entrained with the air during the intake stroke. My experiments show that this temperature is approximately 150° C.

I further provide means for delivering and mixing the cooling liquid with the air entering the compressor and means for shutting off the cooling liquid supply at the desired part of the cycle of operation of the compressor, regardless of the condition of the thermostatic control means.

In a compressor of the type employing a sleeve valve moved by my friction as disclosed in my aforesaid invention, it is difficult to employ water jacket cooling for the cylinder or sleeve walls and my present invention is peculiarly adapted to the cooling of such a compressor. However, it is also applicable to any other form of compressor. To acquaint those skilled in the art with the manner of constructing and practicing the invention, I shall now describe the same in connection with a specific air compressor embodying the invention.

In the drawings, the single figure shows in vertical section a compressor embodying the features and involving the method of the present invention.

In the particular embodiment of the invention shown in the drawings, the compressor is of the type disclosed in my co-pending applications, Serial No. 737,725, filed September 15, 1924, and Serial No. 54,632, filed September 5, 1925.

The base 5 supports the crank case structure 6. The upper section 7 of the crank case structure merges into a cylinder housing 8 having the upper and lower internal annular or cylindrical bearing surfaces 9 and 10 for the sleeve or liner 12 which controls the admission into the cylinder and acts also as a cylinder for the piston 13. The piston 13 is connected by a connecting rod 14 with the crank shaft 15 suitably journaled in the crank case structure 6.

The cylinder housing 8 has a cylinder head 16 which may be secured as by means of cap screws 17 over the upper open end or top thereof. The head 16 contains a suitable seating ring 18 preferably of yielding resilient material. The ring 18 may be mounted in an annular pocket or recess in the head 16 and it is positioned to engage with the annular intumed flange 19 at the upper end of the sleeve or liner 12 to make a fluid tight joint and for noiseless sealing engagement with the upper end of the sleeve or liner 12, which is reciprocated between the limits of its movement by the frictional engagement of the piston 13 therewith.

The cylinder head 16 has a discharge opening 20 which has a valve seat controlled or adapted to be closed by a discharge check valve 22. The discharge valve 22 comprises, in this case, a flat disc disposed within the discharge chamber 25 and held to its seat by a coiled spring 26 interposed between the valve 22 and the inner end of the outlet or discharge fitting or plug 28. The discharge chamber 25 may be formed in the cup-like shell or cylindrical discharge housing 30 and communicates with the cylinder or compression chamber through the discharge passageway 20 when the valve 22 is unseated. The shell or housing 30 may be formed integral with the cylinder head 16 at its lower end and its upper end may be internally threaded at 32 to receive the fitting plug 28 which may have an internally threaded socket 29.

Below its upper end the sleeve or liner 12 has an external or annular flange or shoulder 35 which is adapted to contact or abut with a yielding stop seat or ring 36 for silently stopping the downward movement of the liner 12. The seat or ring 36 is preferably of yielding material and may be made of the same material as the seating ring 18.

The compressor piston 13 has suitable rings 40 for maintaining a fluid tight fit between the piston and the walls of the sleeve or liner 12. The piston may have inclined oil passageways 102 leading through the piston

from the external surface thereof below the piston rings back to the crank case.

The upper end of the liner 12 is surrounded by an annular intake conduit or chest 42 formed in the upper end of the cylinder housing 8. The cylinder housing 8 also has a lateral intake passageway 45 opening into the annular intake conduit 42.

The valve housing 50 is secured as by means of cap screws 47 to the side of the cylinder housing 8 over the passageway 45 with its passageway 48 in communication with or opening into the passageway 45. The housing 50 comprises the part or section in which a passageway 48 is formed and this part may have an externally threaded hub portion 52 to receive the other valve housing part 53 and an annular seat 54 concentrically surrounding the same.

The valve housing 50 has an inlet chamber 56 and the air or other working fluid is admitted through lateral inlet openings 58 and an axial inlet passage to the chamber 56 from which it is drawn or passes through the passageways 48, 45 and conduit 42 into the cylinder or in the charging cycle of the compressor.

While I have embodied my invention as disclosed in an air compressor, it is to be understood that the invention may be employed in compressing other compressible fluids and in fact wherever else found suitable or desirable. Also, while I find water particularly suitable as the cooling fluid and shall describe the invention in connection therewith, it is to be understood that other cooling fluids may be employed in securing partially or completely the improvements of the present invention. Therefore, where I speak of an air compressor or air and a cooling liquid or water, I intend to cover generally a fluid compressor and any suitable cooling liquid or medium.

The axial inlet passage 59 has a seat 60 controlled or adapted to be closed by a combined water cut-off and mixing valve 62. The valve 62 is preferably of conical formation as shown and has a hollow stem 63 guided in a guide 64 held centrally or axially in the passageway 59 by a web or spider formation 65 which properly positions the guide 64 and, at the same time, permits the working fluid and cooling mixture to pass around the guide through the passageway 59 to the compressor. The valve 62 is held to its seat by a coiled spring interposed between it and the guide 64 or the web or spider formation 65, as shown. The valve housing part 53 has an annular seat and an air strainer 67 which may be of suitable screen or mesh formation surrounds and forms an annular intake to the valve housing 50, to prevent the entry of foreign matter into the compressor.

The part or head 53 of the valve housing has an axial depending water or cooling

fluid nozzle or jet 68 provided with a water or cooling fluid inlet passageway 70 which leads from a chamber 72 formed in the hub or valve stem housing 63 which may be integral with the part 53. The water inlet passageway 75 opens at its inner end into the chamber 72 and may be provided at its outer end with a threaded socket 76 to receive the water supply pipe 77, which may lead from any suitable source, as for example, the city water mains or a tank or pump.

The upper end of the passage 70 may be controlled by a water controlling valve 78 which may have a tapered end to seat upon a cooperating seat 79. The valve stem 78 extends through the valve stem housing 73 and the valve stem passage may be sealed against the outward leakage of water or cooling fluid by suitable packing 80 and gland means 82.

At its outer or upper end the valve stem 78 has pivotal connection at 83 with a bell crank arm 84 which has fixed pivotal support at 85 upon a bracket which may be formed integral with the housing part 53.

For the purpose of automatically controlling the quantity of water that may enter the compression chamber during the charging cycle or intake stroke by the temperature of the discharging compressed air, I provide a thermostatic element which may be in the form of a cylindrical rod 86 formed of suitable material such as brass, copper or the like, the expansion or contraction of which with respect to the iron casing 87, will properly control the water control valve 78 in accordance with the desired cooling demands of the compressor.

The thermostatic rod 86 is enclosed in a housing or container 87 preferably of cast iron, which forms a part of the air discharge line from the compressor. The housing 87 has a hollow nipple 88 which may be threaded into the socket 29 of the air discharge plug 28, placing the internal chamber 89 of the housing 87 in communication with the air discharge from the compressor. The opposite side of the housing 87 may have a threaded socket to receive the air discharge pipe 90 which leads to the air storage reservoir or any other desired point.

The thermostatic rod 86 is seated and pinned at one end in a plug member 92 which may be threaded into one end of the housing 87, thereby closing off that end of the housing. The end of the rod 86 is fixed in the plug 92 by a pin 93. The opposite end of the rod 86 extends and is slidable through the opposite end of the container 87 and is free to act upon the arm 94 of the bell crank arm, the passage of the rod 86 through the end of the housing 87 being preferably sealed against fluid leakage by suitable packing 95 and gland means 96.

The projecting or actuating end of the

rod 86 may be provided with an adjustment, so that it may be adjusted to lift the water or cooling fluid control valve 78 from its seat when any desired temperature of the discharging fluid is reached in the chamber 89. This adjusting means may comprise a head 97 threaded upon the rod 86 for contact with the bell crank arm 94 and held firmly in place by a lock nut 98. When the thermostatic element 86 is contracted sufficiently to permit same, the water control valve 78 is held to its seat by a coiled spring 99.

The compressed air and water vapor passes onto the air receiver not shown where the temperature of the same is lowered by contact with the atmospheric air. A cooler may be used. Here the water condenses out and may be removed by hand or automatically as by a suitable trap and, if desired, again used.

While the above construction is shown embodied in a simple single cylinder acting type compressor with control means for maintaining a predetermined temperature in the discharge passageways of the compressor and of the discharging fluid, it is to be understood that the invention may be embodied in multiple cylinder compound compressors and that other variations may be made within the scope of the invention.

The upper end of the piston 13 is provided with a dome or stud 100 for entering the discharge passageway 20 and assuring substantially complete discharge of the compressed fluid, the dome or stud 100 during the downward movement of the piston acting as a suction plunger in the passageway 20. A relatively small port or drill hole 105 is provided at the bottom of the mixing valve chamber to safeguard against flooding the compressor by leakage that might exist at the water valve openings due to defective seatings or the like.

The particular mixing valve which I have shown might be replaced by a suitable carburetor using water instead of hydrocarbon fuel, or any other suitable liquid and gas contact apparatus which can be brought under suitable thermostatic control by the temperature of the compressed air.

The operation of the embodiment shown is as follows:—

Assuming that the discharge air line and the water connection be suitably connected to their respective parts, upon starting the compressor the initial downward movement of the piston 13 moves the liner 12 with it by the ring friction therebetween, until the flange 35 strikes the yielding stop or seat 36. As the upper flanged end of the liner moves away from the yielding seat 18, the combined water cut-off and mixing valve will promptly open, but the thermostatic element being in contracted condition, the

thermo-controlled water valve will remain in closed position and no water will be admitted for cooling purposes.

There is preferably no water admission to the compression chamber until the temperature of the compressed air is sufficiently high to completely evaporate the water that is entrained by the air during the intake stroke. This temperature has been found to be approximately 150 degrees centigrade for single stage compression. Therefore, upon starting the compressor and until the temperature of the compressor rises to such a point that the discharging fluid is raised sufficiently to operate the automatic thermo-control, the water remains shut off even though valve 62 is opened.

While the thermostatic rod 86 is responsive to the temperature of the compressed air discharged by the compressor, it is to be understood that the rise in temperature of the air for an adiabatic compression of from normal room temperature and pressure to discharge pressure of the order of 100# per square inch is not sufficient to cause operation of the thermostatic rod. The cylinder walls and head are conductive and take heat from the air under compression to a greater extent than they give it off. In turn, they heat the incoming air and further increase its temperature. The result is a cumulative effect which builds up the temperature on continuous operation to a temperature which, if not prevented, will be sufficient to destroy lubrication and to destroy the valve seat 18. Hence, the thermostatic element, although it is directly affected by the compressed air temperature, is actually responsive to compressor temperature. The air in this case serves merely as a connecting medium between the compressor itself and the thermostat. The thermostat might be in direct conductive relation to the walls or head of the compressor, but practically this would be difficult to accomplish.

As the temperature of the discharging fluid increases due to heating of the compressor sufficiently to expand the thermostatic element 86 longitudinally, the expansion of said element will, by its contact with the bell crank arm 84 swing said arm in a direction to lift the valve stem 78 from its seat 79, thereby opening the water or cooling fluid inlet to the valve and mixing chamber housing and through same to the compression chamber. The admitted water is graduated by the thermo-controlled water valve so that it is a function of the expansion and contraction of the rod 86 and the expansion and contraction of that rod being a function of the change in temperature of the discharging air and that in turn being a function of the temperature of the compressor, the water admission may be made a function of the compressor temperature, so

that only sufficient water will be admitted to maintain the desired or a predetermined temperature in the compressor at all times.

As the water control valve 78 opens, water passes from the line 77 past the valve 62 with the incoming air when said valve 62 is opened during the suction cycle of the compressor. The conical shape of the valve body 62 breaks up the water by the action of the air in its passage across the lower edge of the valve skirt, tending to atomize and to thoroughly mix the water and air which then pass from the mixing chamber into the compression chamber or cylinder of the compressor.

By admitting the cooling liquid into the compression chamber with the working fluid, the working fluid and the compressor walls are subjected directly to the cooling liquid for the direct transfer of heat instead of through jacket walls or the like. This materially increases the volumetric efficiency of the cooling medium in its cooling function.

Upon a fall in the temperature of the discharging air in contact with the thermal or thermostatic element indicating cooler cylinder walls, the thermal controlled water valve is adapted to close and remain closed until the air temperature again reaches a point where it will open. Upon stopping the compressor, the combined water cut-off and control valve 62 promptly closes under the action of the coiled spring for seating the same and shuts off or closes the air intake. This is purely incidental. At the same time, the upper end of the valve 62 seats in the lower end of the water nozzle 68 and closes off the cooling water supply. This is the desired function. This closes the water supply against leakage where the compressor is stopped with the valve 78 unseated or open under the action of the thermal element, and the thermal element controls the valve 78 independently of the action of the valve 62.

From the foregoing it will now be apparent that I have provided a cooling system and method of increased efficiency, a system and method better adapted to serve the purpose for which intended, and that the quantity of water consumed for cooling purposes is greatly decreased. This eliminates the necessity of maintaining a large supply or reserve of cooling liquid which is especially important where a supply of cooling liquid is not available or where cooling water is expensive.

I do not intend to be limited to the particular details or particular manner of practicing the invention as shown or described.

I claim:—

1. In a compressor having an intake valve, an intake passageway leading thereto, water introducing means actuated by a drop in pressure in said intake passageway to spray water into the current of air drawn through

said intake passageway upon the suction stroke only of the compressor.

2. In a compressor having an intake valve, an intake passageway leading thereto, and water spray means actuated only during the suction stroke to discharge the liquid into the gas flowing through said intake passageway.

3. In combination, a compression chamber having an inlet valve and an inlet for the working fluid, means for delivering a cooling fluid to said inlet, and a suction operated valve in said inlet for controlling the working and cooling fluid supplies.

4. In combination, a compression chamber having an inlet for gas, means for delivering a cooling fluid to said inlet, a valve in said inlet for controlling the gas and cooling fluid supplies, said valve being formed to mix the gas and cooling fluid in their passage to the compression chamber.

5. In combination, a vertical cylinder housing having a movable liner, a piston operable in said liner, said housing having a conduit surrounding the top of the liner and being disposed partly below the top of the liner, a working fluid inlet opening into said conduit, means for delivering a cooling liquid to said working fluid inlet and a combination working and cooling fluid cut-off and mixing valve in said inlet.

6. In a compressor, a compressor cylinder, an intake valve, a suction pipe therefor, and a suction operated water atomizing device discharging into said suction pipe only when a current of gas is flowing there-through in response to suction.

7. In combination with a compressor having a piston and a cylinder, an inlet passageway for the cylinder, and a water mixing valve opened by the piston on its suction stroke to discharge water into the stream of gas drawn into the inlet gas passageway.

8. In combination with a compressor having a piston and a cylinder, an inlet gas passageway for the cylinder, and a movable barrier in the inlet passageway, means for spraying water into the air passing said barrier, and a valve operated by said barrier for controlling said means.

9. In combination with a compressor having a piston and a cylinder, an inlet gas passageway for the cylinder and a movable barrier in the inlet passageway, means for spraying water into the air passing said barrier, a valve operated by said barrier for

controlling said means, a discharge gas passageway for the cylinder, and a thermostatic element subject to the temperature of the gas in the discharge passageway for controlling the water delivered by said means.

10. In combination with the intake passageway of a compressor, a mixing valve comprising a passageway communicating with a source of cooling liquid, a movable valve member normally closing said cooling liquid passageway and the air inlet passageway, and spring means for holding said valve in closed position.

11. In combination with the intake passageway of a gas compressor, an intake valve controlling said passageway, a source of water, a suction operated metering device for injecting water from said source into the current of gas drawn by the compressor through the intake passageway, and means for separating out any water not in suspension in said intake passageway.

12. The method of cooling a gas compressor which comprises moving the piston outwardly in the cylinder to create a drop in pressure in the cylinder and intake passageway of the compressor, causing a flow of air into the cylinder by said drop in pressure, injecting cooling liquid into the flowing current of air in accordance with the drop in pressure, and carrying the cooling liquid in suspension in the current of air into the cylinder.

13. In combination, a compressor having a cylinder, a lateral air intake passageway into the cylinder, an atomizer casing supported on said cylinder and having a passageway communicating with said intake passageway, a spring loaded valve in said casing normally closing off the passageway to the casing, said casing having a liquid passageway terminating in a discharge port also controlled by said spring loaded valve, a needle valve for said liquid passageway for controlling the rate of liquid delivered to the discharge port, said cylinder having a discharge passageway, a thermostat housing communicating with said discharge passageway and mounted on said cylinder, a thermostatic rod in said housing subject to the temperature of the gas discharged from the compressor and connected to said needle valve.

In witness whereof, I hereunto subscribe my name this 6th day of November, 1925.

BURTON S. AIKMAN.