



US 20050204993A1

(19) **United States**

(12) **Patent Application Publication**

Lang

(10) **Pub. No.: US 2005/0204993 A1**

(43) **Pub. Date: Sep. 22, 2005**

(54) **SPRAY COVER**

Publication Classification

(76) Inventor: **Christoph Lang**, Moosach (DE)

(51) **Int. Cl.7** **B63B 35/00**

(52) **U.S. Cl.** **114/347**

Correspondence Address:

MILDE & HOFFBERG, LLP

10 BANK STREET

SUITE 460

WHITE PLAINS, NY 10606 (US)

(57) **ABSTRACT**

(21) Appl. No.: **10/516,871**

(22) PCT Filed: **Jun. 20, 2003**

(86) PCT No.: **PCT/EP03/06549**

(30) **Foreign Application Priority Data**

Jun. 21, 2002 (DE)..... 202 09 672.6

The invention relates to a spray cover or hatch cover for boats, e.g., kayaks (10), comprising a pull element, which is provided on one edge of the cover (20) and which extends in a peripheral direction, for detachably fixing the cover to a collar (the coaming) (14) surrounding the opening to be covered and protruding away from the body of the kayak. The pull element is a tightening strap which cannot be directly expanded by hand or which can only be thus expanded with difficulty. At least one manually operable tightening element (35) is inserted therein.

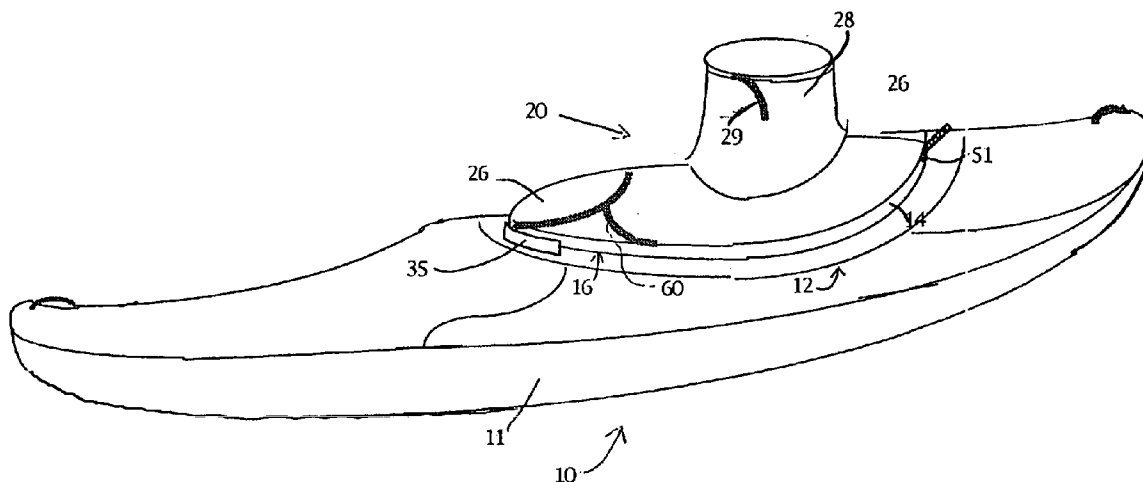

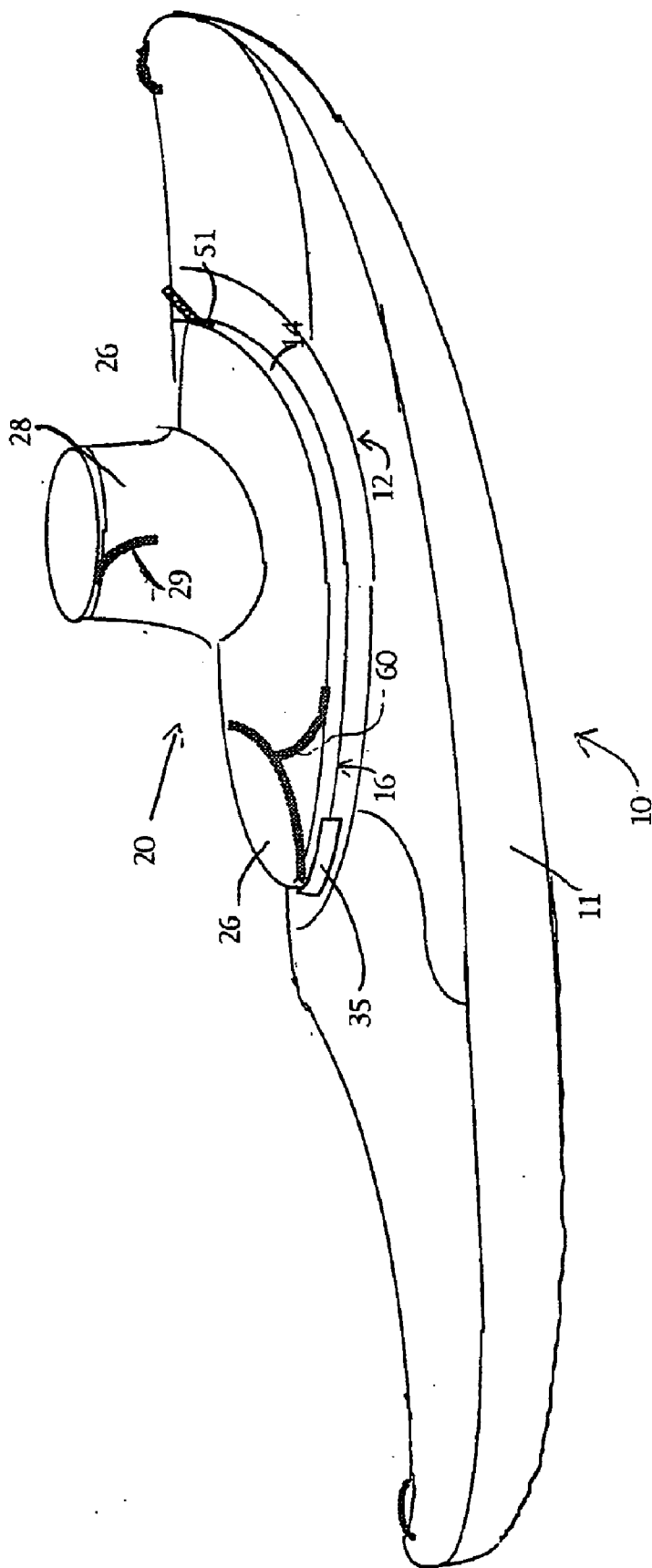

Fig. 1

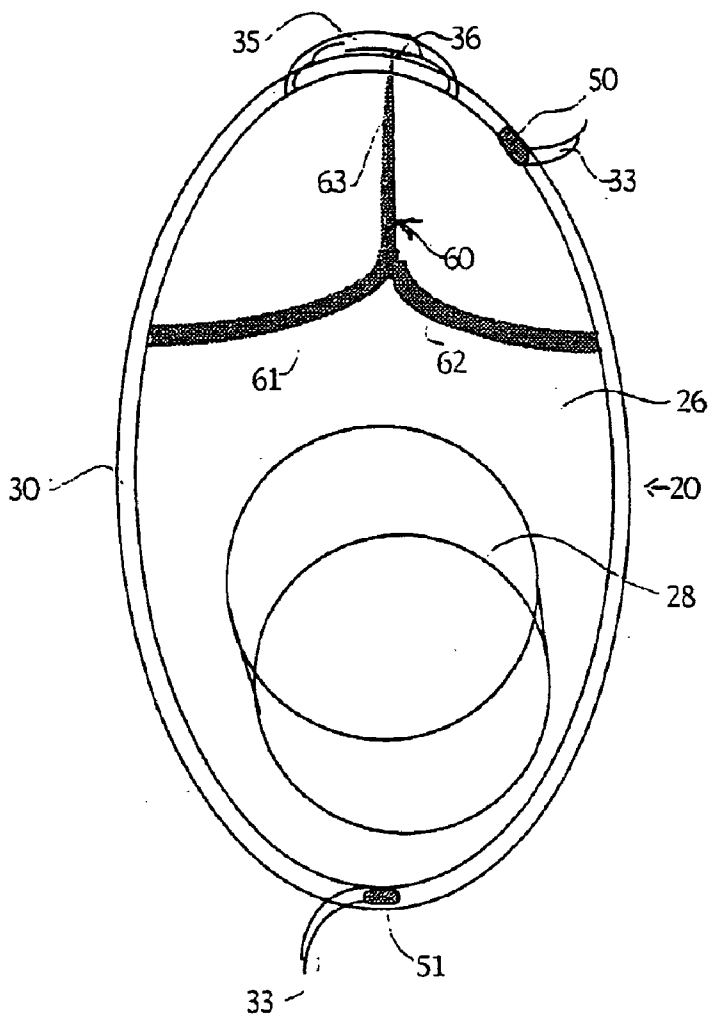

Fig. 2

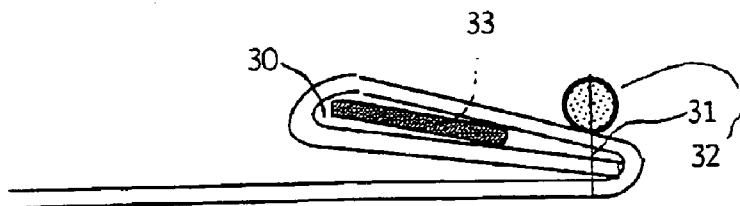

Fig. 3

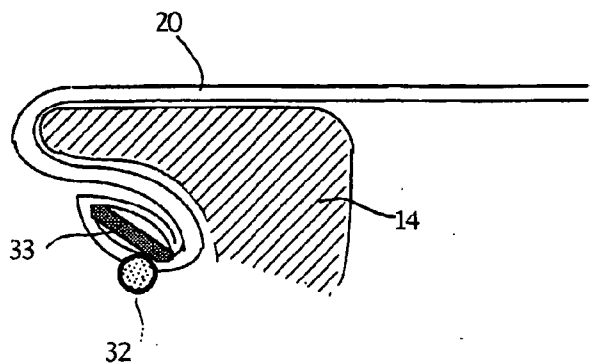

Fig. 4

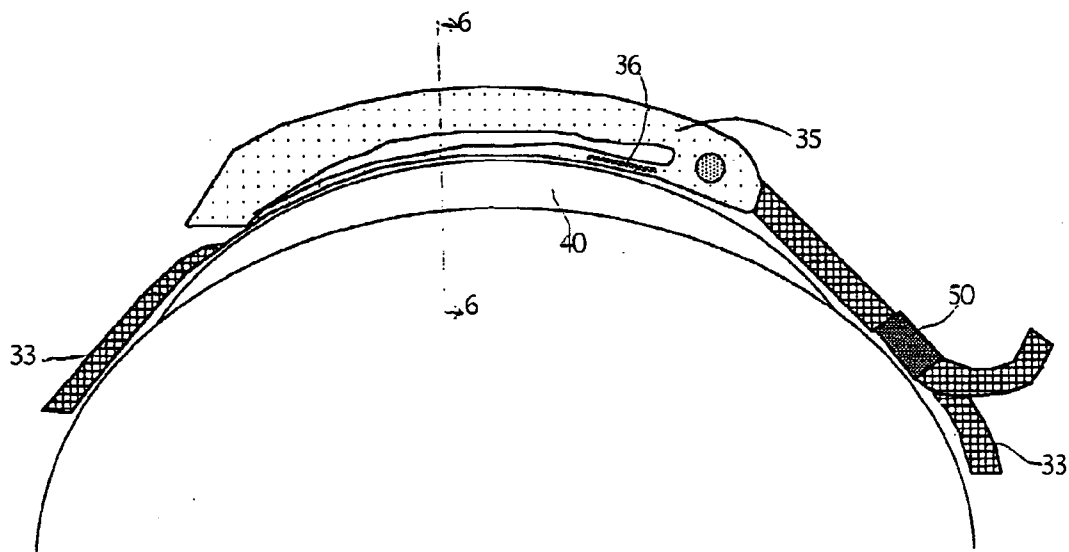

Fig. 5

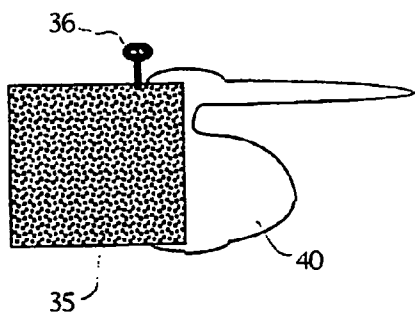

Fig. 6

Fig. 7

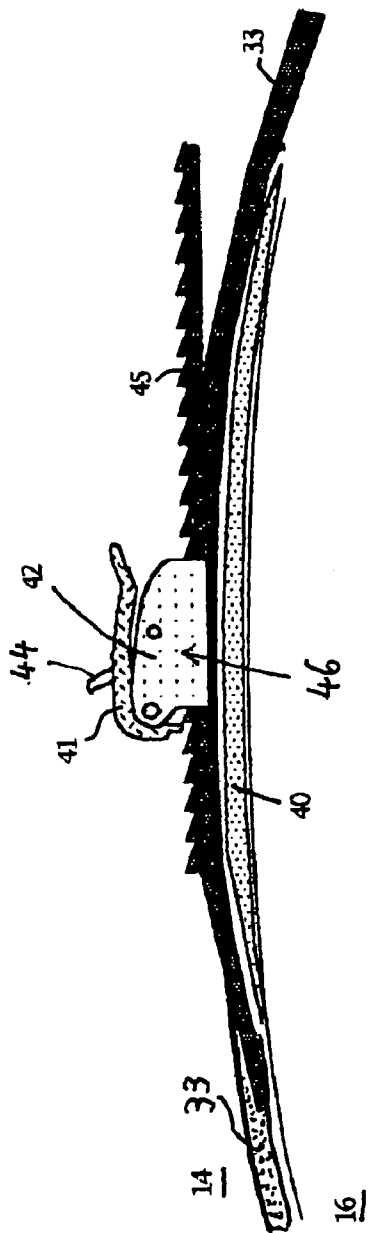
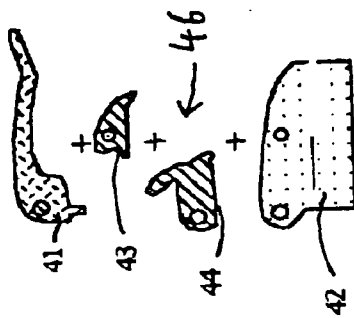

Fig. 8



SPRAY COVER

[0001] The invention relates to a spray cover or hatch cover for boats, particularly kayaks based on the overall concept of Patent Claim 1.

[0002] Kayaks possess a mainly closed body with a seat opening on its upper side from which the upper body of a kayaker seated in the kayak extends upward. So-called spray covers serve to seal the opening against intruding water. These are made of a flat piece of waterproof, flexible material, as a rule neoprene with embedded expanding fabric, but possibly PVC or nylon. The spray cover possesses a first section, the so-called "chimney", that surrounds the upper body of kayaker like a garment, and a second, ring-formed projecting section whose outer edge is attached to the boat body to form a seal after the kayaker has entered the kayak. A so-called "coaming" is provided for attachment to the boat, which is a collar with a tapering cross-section projecting upward surrounding the opening to be sealed. It has a diameter that gradually increases upward, thus forming an outer surrounding channel.

[0003] Conventional spray covers possess a circumferential pull element of elastic material at their edge that is expanded by hand and placed into the coaming channel. The elastic pull element, e.g., a rubber cord, may be stitched to the edge of the spray cover or inserted into a hollow seam. A shaped or attached shaped piece is often involved that is specially shaped to improve the seal to the outer contour of the coaming.

[0004] Since the pull element lies in the channel of the coaming and is under tension, the spray cover cannot be removed from the coaming without other steps. The strength of the connection, and thus the strength of the seal against water, depends on the elastic tension created by stretching the spray cover by hand. This tension, of course, is limited. In particular, women cannot always exert the force required to mount the spray cover onto the coaming. It therefore often occurs that conventional spray covers are unintentionally released in extreme situations in which they receive heavy water loading from high-pressure splashing or wave pressure in white-water situations, leaving the boat no longer protected against intruding water.

[0005] Spray covers for other types of boats suffer from the same problem, if not to such a severe degree. One example is a canoe, in which one kneels, and another is a so-called hatch cover to cover luggage or a seat opening in a boat. Hatch covers, of course, have no chimney, but rather are complete covers. Nevertheless, they are attached to the coaming surrounding the luggage opening in the same fashion as for spray covers. The invention has the objective of further developing existing spray covers or hatch covers so that security against involuntary release from the coaming is greatly increased without requiring excessive force to attach it, or totally preventing weaker persons from attaching it.

[0006] This objective is achieved by the invention by means of the spray cover or hatch cover described in Patent Claim 1, whereby advantageous embodiments derive from the Dependent Claims.

[0007] In the spray cover based on the invention, the pull element is an elastic band that practically cannot be expanded by hand. The pre-tension required to secure the

cover to the coaming and to seal the cover to the coaming is applied using at least one manually operable tightening device that is inserted into the tightening strap. The tightening device is so shaped that it is shortened by manual actuation, usually via a lever, thus creating the tension in the tightening strap. Even a weaker person may mount the spray cover or hatch cover according to the invention to the coaming using the tightening device. The tightening strap, when the tightening device is open, is inserted into the coaming channel, and the tightening device is then closed. This securing will withstand larger external loads since the tightening strap is stretched only after it is inserted into the coaming channel, and since the spray cover or hatch cover is thus secured by an approximate form fit to the coaming.

[0008] The degree or measure by which the tightening strap cannot be expanded by hand, or only with great difficulty, must be understood in connection with this mode of function: It must be so difficult to expand that external forces acting on the cover are not adequate to cause sufficient expansion to allow the tightening strap to slip from the coaming channel. Suitable tightening straps preferably are made of plastic, e.g., polypropylene.

[0009] Two tightening devices are preferably inserted into the tightening strap. Depending on the tightening device design and the depth of the coaming channel, it is possible that one tightening device is not adequate to lengthen the tightening strap adequately so that it may be conveniently stretched over the upper edge of the coaming and placed into the channel in the coaming. Also, two tightening devices provide a safety function, particularly when they are positioned per Claim 3 along the travel direction of the boat, one each at the front and rear ends of the cover. Kayaks suffer so-called jam accidents in which the boat is trapped under an obstacle such as a rock either by its keel or its deck. The rescuer who tries to extract the kayaker in such a situation must be able to release the spray cover, and thus requires access to at least one tightening device, which is almost always the case in the embodiment based on Claim 3. Of course, each individual tightening device must be so adjusted for this situation that the spray cover is completely free of the coaming with one open tightening device, thus allowing its removal.

[0010] As a tightening device, it is possible to use the type of tensioner employed to secure the top of a barrel. The tensioner possesses an actuation lever that may be pivoted from its open position over a cam point into the secured position, shortening the sealing band when the lever is closed. The resultant lever action thus provides high tension in the tightening strap, and the cam-function design ensures that the actuation lever remains securely in its closed position.

[0011] Since the tensioning distance of a tensioner is limited, one preferably includes at least one adjuster to pre-tension the tightening strap by changing its length when using them. Such an adjustment fitting allows exact matching of the tightening strap to various coaming circumferences.

[0012] The adjusting device may also include a manually operable release for spontaneous lengthening or separation of the tightening strap. Instead of the tensioner, this release device is then actuated during an emergency of the above-mentioned type. The release may be so configured that a

lower amount of force is required than for the tensioner. For example, the adjusting device may be a self-affixing element at which an end of the tightening strap projects, and a brief tug on the extended end releases the clamp. Two adjusting devices are preferably provided for emergency release for the same reason, and in the same configuration, as was described previously with reference to the tensioners.

[0013] A very advantageous alternative to the tensioner is a so-called pump clasp (or clamp) used as a tightening device. Such pump clasp tensioners are also known. They are configured to work with a ratchet band or toothed belt that is drawn into the pump clasp step-by-step by repeated actuation of the lever. This allows the length of the tightening strap, with one end in the ratchet band and the other at the actual adjustment element, to be altered over a wide range and finally to be shortened to the extent that the necessary tension results. Special adjusting devices are thus not required in connection with pump clasp tensioners.

[0014] Pump clasp tensioners have the further advantage that they may be completely opened very easily and spontaneously, either by means of a release button, or by placing the tensioning lever into a special release setting. Thus, one component may very advantageously provide the three functions of pre-tensioning, tensioning, and spontaneous, complete release of the tightening strap.

[0015] Pump clasp tensioners suitable for use with the invention are provided, for example, by GUDO AG, 8618 Oetwil, Switzerland under the designations Mini N 4, Part Order Number 1663, or Mega K 4, Part Order Number 1751.

[0016] Inclusion of two pump clasp tensioners in the tightening strap is recommended for the above-mentioned safety reasons even when pump clasp tensioners are used as tightening devices. One must achieve a configuration in which the two pump clasp tensioners are positioned to the sides of the boat when the spray cover is in the use position, and thus may be easily actuated by the seated kayaker since, in contrast to the tensioner, simple actuation of the lever is necessary here to tighten the tightening strap.

[0017] If a boat capsizes, the kayaker must be able to free him/herself spontaneously with no problem even when panicked, which requires release of the spray cover. With conventional spray covers, this occurs simply in that the kayaker sitting in the boat presses with his legs against the spray cover, thus pulling the elastic pull element from the coaming. Configuration of the spray cover according to the invention per Claim 9 allows the same semi-reflexive release of the spray cover in that the kayaker presses his/her knees indirectly against the release mechanism of at least one tightening device and/or adjusting device by means of the release mechanism provided on the upper side of the spray cover. The release device per Claim 10 preferably includes a release band that stretches across the thigh or knee of the person sitting under spray cover that reproduces the upward movement of the legs, and per Claim 11, transfers it by means of at least-one pull strap to the release mechanism so that the fastener opens and releases the tightening strap.

[0018] In order to simplify the initial mounting of the spray cover or hatch cover to the coaming, an additional elastic band that extends circumferentially along the edge of the cover and that may be stretched by hand may be provided that then is inserted into the channel in the coaming

before the tightening strap is tightened using the tightening device or tightening devices. In contrast to the state of the art, this elastic band has practically no securing function during cover use. It merely simplifies the prior attachment of the cover to the coaming as long as the tightening strap is still loose. The elastic band may be a simple rubber cord, for example, such as are used for elastic cargo straps. The rubber cord is preferably stitched to the edge of the cover. The seam used for this may also be used to form the hollow channel at the edge of the cover in which the tightening strap is held. Alternatively, the rubber cord or the tightening strap may be formed as a tube within which another band is placed. It may be adequate for the rubber cord not to extend along the entire length of the coaming, but rather only over a shorter portion of the path, with its ends secured to the adjacent tightening strap. This causes the tightening strap to be shortened by the elastic band between the securing points, and gives it light pre-tension adequate to secure the spray cover until it is shortened and stretched within the channel by the tightening device, and this shortening disappears because of the-rubber cord.

[0019] In a further embodiment of the invention, the tightening strap may be held within a series of tubes or rings at the edge of the cover.

[0020] In use position of the spray cover, one or the other tightening device for the tightening strap lies within the channel in the coaming. If it is particularly deep, it may simplify operation to assign a formed piece to each tightening device per Claim 18 that lies between the tightening device and coaming that determines a specific position for the tightening device relative to the coaming in which the tightening device is easy to operate and/or in which the pull of the above-mentioned release device is particularly easily accessible. These shaped pieces may be of foamed plastic, for example. Separate formed pieces allow the use of conventional tightening devices. Alternatively, the tightening devices may also have a shape that is matched to the contour of the coaming.

[0021] In the following, the invention is described in greater advantageous detail by the use of schematically represented embodiments, which show:

[0022] FIG. 1 a kayak with spray cover based on the invention in oblique view;

[0023] FIG. 2 a top view of the spray cover;

[0024] FIG. 3 a cross-sectional view through the edge of the spray cover;

[0025] FIG. 4 a cross-sectional view through the coaming of the kayak with spray cover in position;

[0026] FIG. 5 a top view of a section of the spray cover with tensioner and adjusting device;

[0027] FIG. 6 a cross-sectional view along the projection 6-6 in FIG. 5;

[0028] FIG. 7 a top view of a section of another spray cover with ratcheting strap and pump clasp;

[0029] FIG. 8 details of the pump clasp from FIG. 7 in a simplified, exploded view.

[0030] FIG. 1 shows a kayak 10, a boat body 11 with a seat opening 12 for the kayaker. The seat opening 12 is

surrounded by a heightened collar of one piece with the boat body (the so-called coaming 14); see FIG. 4. The coaming 14 decreases in diameter upward from the boat body forming an exterior channel in the coaming.

[0031] A spray cover 20 of neoprene with embedded fabric to exclude intruding water covers the seat opening 12. The spray cover 20 includes two sections, namely the so-called chimney 28 and a separate ring section. The chimney 28 covers the kayaker's upper body like a garment, and is held as close as possible to the upper-body by means of a cord 29. The ring section extends laterally from the lower end of the chimney, and covers the hatch area of the seat opening between the kayaker's body and the coaming 14.

[0032] When the kayaker has seated him/herself in the kayak 10 with the spray cover in position, the ring section of the spray cover 20 is attached to the coaming to form a seal. For this purpose, the edge of the spray cover 20 includes a circumferential, hollow tubular cavity formed by folding the spray cover material and secured by a seam 31. The seam 31 simultaneously contains a rubber cord 32 extending circumferentially that is relatively easy to stretch by hand. A flat, practically non-expandable tightening strap 33 of polypropylene is inserted into the hollow cavity 30.

[0033] At the bow end of the spray cover 20, a tensioner 35 is inserted into the tightening strap 33, for which purpose the tightening strap extends out of the hollow cavity 30 there. The tensioner 35 possesses an actuation lever 36 that may be pivoted out of an opening position (not shown) in which the actuation lever 36 stands out from the body of the tensioner into the locked position shown in FIG. 5, whereby the cam point has been exceeded. In its opening position, the two ends of the tightening strap at the tensioner are far apart, but this separation is reduced by pivoting the actuation lever into the secured position, whereby the lever action allows tension to be applied to the tightening strap.

[0034] A formed piece 40 of plastic foam is inserted between the tensioner 35 and the coaming 14 whose one side is matched to the cross-section of the coaming and whose other side is matched to the shape of the tensioner 35, thus locating the tensioner 35 at a position somewhat outside the channel 16 in the coaming 14, see FIG. 6. Also, the shaped body 40 possesses pointed ends so that the pull strap undergoes a gradual transition to the tensioner 35 positioned at the exterior.

[0035] An adjusting device 50 is inserted into the tightening strap 33 directly adjacent to the tensioner 35, by means of which the length of the tightening strap may be altered as long as it is not under tension. This is a self-adhering fitting of conventional design whose holding force increases as the tension in the tightening strap increases. The tightening strap may be passed once or several times through the fitting to guard against exceeding the highest-possible holding force of the adjusting device in order to reduce the tensile force on the fitting before it is held by the adjusting device. The tightening strap clamped within the fitting has its short end extending away from the fitting. By pulling obliquely on this end, the clamping force may be completely removed, immediately releasing the tightening strap completely.

[0036] Another identically-designed self-adhering adjusting device 51 is inserted into the tightening strap 33 in the stern end of the spray cover.

[0037] In the front area where the kayaker's legs are located under the spray cover 20, a release band is provided on the spray cover. The release band consists of two sections 61 and 62 that meet in the center at an obtuse angle. Both ends of the release band are attached to the spray cover 20 so that it extends approximately obliquely to the direction of travel, with the acute angle facing forward and lying on the spray cover without slack. The one section 61 of the release band is lengthened away from the center, forming a pull strap 63 whose loose end is attached to the actuation lever 36 of the tensioner 35.

[0038] To attach the spray cover to the coaming, first the rubber cord 32 is stretched slightly by hand and inserted into the channel in the coaming 16. For this, the tensioner 35 is open. Next, by actuating the actuation lever 36, the tensioner 35 is closed, thus placing tension on the tightening strap 33 within the hollow cavity 30. In case the tensioner cannot be closed, or if there is slack in the pull strap, the length of the tightening strap 33 may be altered appropriately at the adjusting device 51. The tightening strap under tension because of the closed tensioner lies within the channel in the coaming 16 along with the rubber cord and holds the spray cover practically to a formed fit, so that even high waves cannot cause the spray cover to be pulled from the coaming.

[0039] In an emergency, rescuers can release the spray cover immediately and without difficulty by pulling the extended end of the tightening strap either at the adjusting device 50 or, if it is not accessible, at the rear adjusting device 51, thus completely releasing the tightening strap and thereby the spray cover.

[0040] The kayaker him/herself can release the spray cover immediately even in a panic situation by raising the release band with his/her knees, thereby causing the actuation lever 36 of the tensioner 35 to pivot into the open position, and thus causing the tightening strap to loosen, allowing the spray cover to be pulled upward off the coaming.

[0041] Another embodiment of the spray cover according to the invention distinguishes itself from the above in that the two tensioners 35 are replaced by two pump clamp tensioners, each of which possesses a ratcheting strap 45 operating with it, but not with special adjusting devices 50, 51. Also, the two clamp tensioners are positioned not at the bow and stern ends of the spray cover, but rather at the sides, where the kayaker can easily reach and operate them. In a view similar to FIG. 5, FIG. 7 shows the position of the first pump clasp 46. The second pump clasp is not shown, but is shaped the same as the pump clasp 46, and is positioned on the spray cover to be mirror-reflected.

[0042] Per FIG. 7, one end (the left end in FIG. 7) of the tightening strap 33 passing along the edge of the spray cover but separated at the pump clasp 46 is connected to a conventional ratcheting strap 45 that extends as an extension of the tightening strap 33. The other end of the tightening strap 33 is firmly affixed to the pump clasp 46. It possesses a body with a U-shaped cross-section through which the ratcheting strap 45 extends. The configuration of ratcheting strap 45 and pump clasp 46 is located, like the tensioner 35 of the first embodiment example, within the channel 16 in the coaming 14, but projects out of the channel 16 from between the inserted shaped bodies 40 far enough that the kayaker can actuate the tensioning lever of the pump clasp 46.

[0043] When the spray cover is in opened configuration, the free end of the ratcheting strap 45 in the vicinity of the clasp body. The length of the ratcheting strap 45 is so selected that the spray cover with its tightening strap 33 may be easily inserted into the channel 16 in the coaming 14. Next, the user again actuates the tensioning lever 41. With each pivoting of the clasp body 42, the tightening strap 45 is drawn by the tensioning lever 41 further into the pump clasp 46 by one ratchet width. A blocking wedge 43 mounted within the clasp body 42 (see FIG. 8) engages with the ratchet teeth of the ratcheting strap 45, preventing its slippage. This process is continued until the tightening strap 33 is taut against the coaming 14, and is under such tension that the spray cover cannot be removed from the coaming.

[0044] An additional release lever 44 is mounted within the clasp body 42 so that it may pivot (see FIG. 8) that projects outward with an extension through a corresponding recess in the tensioning lever 41 and engages by its nose with the blocking wedge 43 so that the blocking wedge 43 is raised out of engagement with the ratchet teeth of the ratcheting strap 45 by pressure on the actuation extension. This releases the ratcheting strap 45 from the pump clasp 46, and may slide out of it to the extent that the resulting slack of the tightening strap 33 is adequate to allow removal of the spray cover from the coaming. The user or a rescuer may thus free the spray cover from the kayak without delay by actuation of the release lever 44.

What is claimed is:

1. Spray In a spray or hatch cover for boats, e.g., kayaks, having a pull element that is a circumferential elastic band provided at the edge of the cover for simple release of the cover at the collar (coaming) projecting above the boat body and surrounding the an aperture to be covered,

the improvement wherein

the pull element is a tightening strap that can be expanded by hand only with great difficulty, and wherein the pull element includes at least a one manually-operable tightening device for tightening the strap.

2. Spray or hatch cover as in claim 1, wherein the pull element includes two tightening devices for tightening the strap.

3. Spray or hatch cover as in claim 2, wherein a first tightening device is located at a bow end of the spray cover in its attached position, and a second tightening device is located at a stern end of the spray cover.

4. Spray or hatch cover as in claim 1, wherein the tightening device is a tensioner.

5. Spray or hatch cover as in claim 4, wherein at least one adjusting device is inserted into the tightening strap to adjust the length of the tightening strap.

6. Spray or hatch cover as in claim 5, wherein each adjusting device includes a manually operable release mechanism for spontaneous extension or separation of the tightening strap.

7. Spray or hatch cover as in claim 6, wherein a first adjusting device is located at a bow end of the spray cover in its attached position, and a second adjusting device is located at a stern end of the spray cover.

8. Spray or hatch cover as in claim 1, wherein the tightening device is a pump clasp with a ratcheting strap working with it.

9. Spray cover as in claim 1, further comprising a release mechanism provided on the upper side of the spray cover that is located in use position above the legs of the person sitting under the spray cover, and is actuated by raising the legs, and provides an opening mechanism to at least one of the tightening and adjusting devices.

10. Spray cover as in claim 9, wherein the release mechanism includes a release band connected at both ends to the spray cover, which in use position of the spray cover lies somewhat oblique to the legs of the person seated under the spray cover and has practically no slack, whereby the spray cover may be stretched out oblique to its plane because of at least one of the elasticity of the material and its dimensions that are greater than those of the aperture of the boat.

11. Spray cover as in claim 10, further comprising a pull strap that extends to at least one of the tightening device and adjusting device assigned to the opening mechanism and located at a stern end of the spray cover.

12. Spray or hatch cover as in claim 1, further comprising an additional rubber cord that is stretchable by hand is provided for prior positioning of the cover on the coaming.

13. Spray or hatch cover as in claim 12, wherein the rubber cord is stitched to the edge of the cover.

14. Spray or hatch cover as in claim 1, wherein the tightening strap is held within a hollow cavity at the edge of the cover.

15. Spray or hatch cover as in claim 12, wherein the rubber cord is held by the seam that forms a hollow cavity at the edge of the cover.

16. Spray or hatch cover as in claim 12, wherein at least one of the rubber cord and tightening strap is shaped as a tube in whose interior the tightening strap and the rubber cord, respectively, extends.

17. Spray or hatch cover as in claim 12, wherein the rubber cord is held within a series of loops or rings at the edge of the cover.

18. Spray or hatch cover as in claim 1, further comprising a shaped piece As inserted into the spray cover in use position between the tightening device and the coaming, and whose shape is matched on the one side to the contour of the coaming, and on the other side to the shape of the tightening device.

19. Spray or hatch cover as in claim 1, wherein the shape of the rear side of the tightening device matches the shape of the coaming.

* * * * *