

Jan. 16, 1968

W. HEINZ

3,363,275

TOOTH-BRUSH AND COMB HOLDER AND CLEANER

Filed Jan. 26, 1966

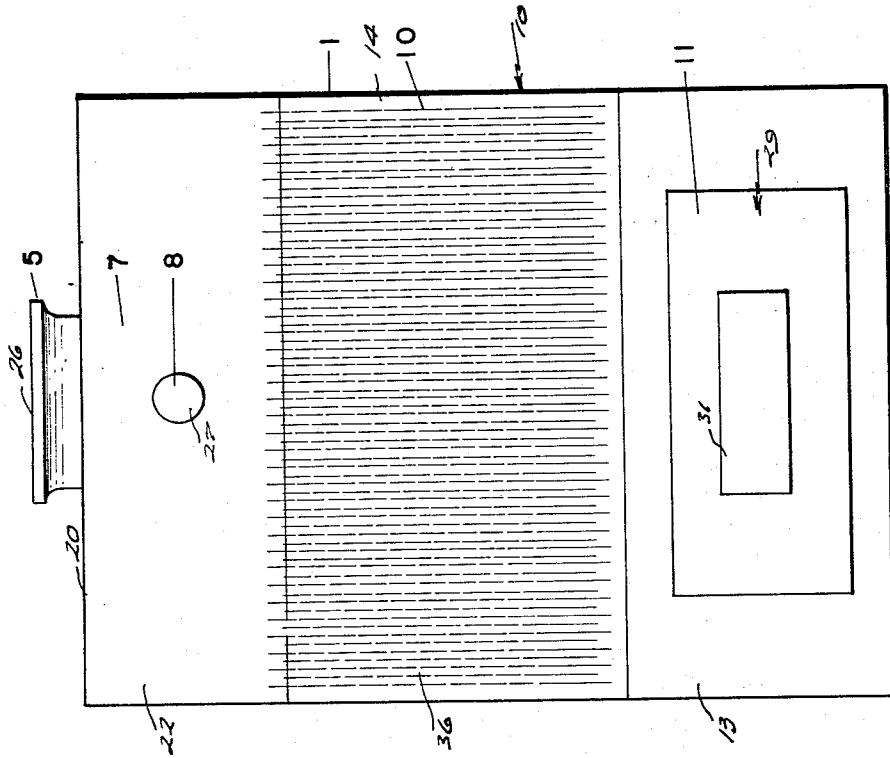

FIG. 2

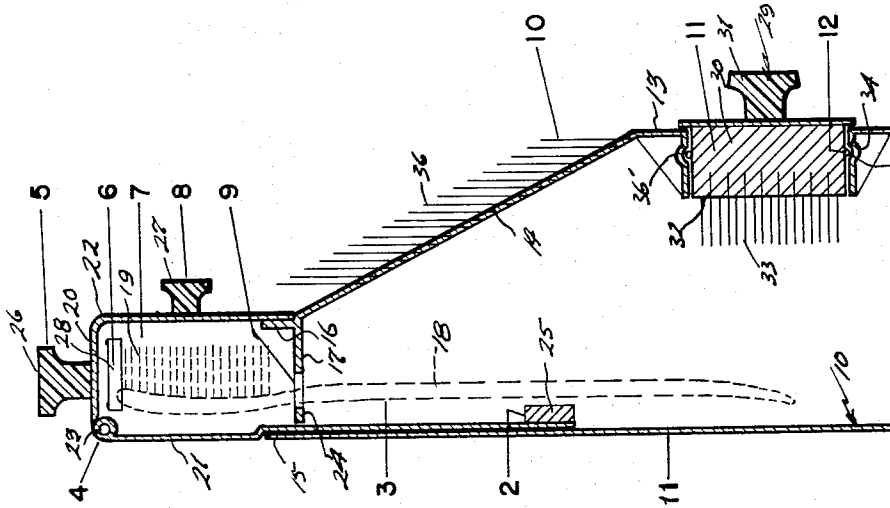

FIG. 1

INVENTOR
WILLIAM HEINZ
By *[Signature]*
HIS ATT'Y

1

3,363,275

TOOTH-BRUSH AND COMB HOLDER AND CLEANER

William Heinz, 2220 40th St. SE., Calgary, Alberta, Canada

Filed Jan. 26, 1966, Ser. No. 523,160

3 Claims. (Cl. 15-104.5)

My invention relates to new and useful improvements in combination tooth-brush and comb holder and cleaner devices.

Normally tooth-brushes are either rested on a shelf in the bathroom or engaged within a rack open to the air. Furthermore, there is no normal method for storing combs in a bathroom consequently same are also rested upon a shelf. I have overcome these disadvantages by providing a container including means for storing tooth-brushes therewithin and for holding combs on the front surface thereof ready for immediate use. Furthermore I provide a detachable cleaner for combs so that the teeth can readily be cleaned.

The principal object and essence of my invention is therefore to provide a device of the character herewithin described which provides a closed storage area for tooth-brushes and a rack for holding combs upon the front surface thereof.

Another object of my invention is to provide a device of the character herewithin described which includes means whereby combs can be cleaned readily.

A yet further object of my invention is to provide a device of the character herewithin described which can be hung in a convenient location within the bathroom adjacent the washbasin.

Still another object of my invention is to provide a device of the character herewithin described which is simple in construction, economical in manufacture, and otherwise well suited to the purpose for which it is designed.

With the foregoing in view, and all those objects, purposes or advantages which may become apparent from consideration of this disclosure and specification, the present invention consists of the inventive concept embodied in the method, process, construction, arrangement of parts, or new use of the same, as herein particularly exemplified in one or more specific embodiments of such concept, reference being had to the accompanying figures in which:

FIGURE 1 is a section side elevation of my device.

FIGURE 2 is a front plan view thereof.

In the drawings like characters of reference indicate corresponding parts in the different figures.

Proceeding therefore to describe my invention in detail, my device consists of a container collectively designated 10 including a substantially vertical rear side 11, a base 12, a lower front side 13 and an upwardly and rearwardly inclined front side portion 14.

The device may be attached to the wall by any conventional means (not illustrated) and it is preferably located near the washbasin within the bathroom.

Spanning the rear side 11 and upper front side 14 adjacent the upper ends 15 and 16 is a slotted plate 17 adapted to receive tooth-brush handles 18 and retaining the heads 19 thereabove as clearly shown in FIGURE 1. A cover 20 is provided and adapted to cover the tooth-brush heads 19 and in the embodiment illustrated I show two methods for attaching this cover on the container. Firstly the cover includes a rear wall 21 and a front cover

2

wall 22 hingedly connected to the upper edge of the rear wall by means of hinge 23. The rear wall extends downwardly in contact with the inner surface of the rear side 11 of the container and passes through a slot 24 within the member 17 adjacent the rear side 11. A slot 25 is provided upon the lower end of the rear wall 21 so that by means of knob 26, the entire cover may be moved vertically upwardly from the container so that the tooth-brushes can be removed. Alternatively, knob 27 can be used to hingedly open the portion 22, once again giving access to the tooth-brushes therewithin. It will be noted that louvers 28 are provided in the ends of the cover to prevent condensation of moisture which may be present upon the tooth-brushes while they are in the container.

Within the vertical front wall 13 of the container is a comb cleaning device collectively designated 29 consisting of a block 30 having a knob 31 thereon. Extending from the inner face 32 of the block is a plurality of bristle-like elements 33 which facilitates the cleaning of the comb teeth. This block is held within the aperture 34 in the wall 13 by means of protruding portions 35 engaging within recesses 36' as clearly shown in FIGURE 1.

Secured to and extending vertically upwards from the sloping upper front surface 14 of the container is a plurality of bristle-like elements 36 which are adapted to engage the teeth of a comb placed transversely thereacross thus holding the comb or combs in a racked position ready for use. These bristles can either be of nylon or other suitable material and should be close enough together to hold the comb by engagement with the teeth thereof, without any displacement occurring.

Since various modifications can be made to the invention herein described within the scope of the inventive concept disclosed, it is not intended that protection of the said invention should be interpreted as restricted to the modification or modifications or known parts of such concept as have been particularly described, defined, or exemplified, since this disclosure is intended to explain the construction and operation of such concept, and not for the purpose of limiting protection to any specific embodiment or details thereof.

What I claim as my invention is:

1. A tooth-brush and comb holder and cleaner comprising in combination a container, a detachable lid for said container, tooth-brush holding means in said container, and a comb holder on the front side of said container, said comb holder comprising a plurality of bristle-like elements extending upwardly from said front side adapted to mesh with the teeth of the comb being held thereby.

2. The device according to claim 1 which includes a comb cleaner detachably secured within said container, said comb cleaner comprising a block, and a plurality of comb teeth engaging elements extending from one side of said block.

3. A holder for combs comprising a container, an upwardly and rearwardly inclined front side on said container, and comb teeth engaging means extending from said front side, said comb teeth engaging means comprising a plurality of bristle-like elements extending vertically upwards from said front side and upon the outer surface thereof.

No references cited.

65 CHARLES A. WILLMUTH, *Primary Examiner*.
L. G. MACHLIN, *Assistant Examiner*.