



US 20030155389A1

(19) **United States**

(12) **Patent Application Publication**
Swartzentruber

(10) **Pub. No.: US 2003/0155389 A1**

(43) **Pub. Date: Aug. 21, 2003**

(54) **SLAP ON WATCH**

(52) **U.S. Cl.** 224/164

(76) **Inventor: Vincent Dale Swartzentruber,**
Fredericktown, OH (US)

(57) **ABSTRACT**

Correspondence Address:
Vincent Dale Swartzentruber
6049 Bryant Road
Fredericktown, OH 43019 (US)

A Slap on Watch consists of a watch face or timepiece (22) that is attached to a slap on band (10). The slap on band includes the component of a bistable spring metal (12), which will coil when slapped against the appropriate object such as a human wrist. When slapped against the wrist, the Slap on Watch will automatically form to the wrist, securing the watch to the wrist. The slap on band exists in two states; the elongated state, and the coiled state. The watch face in this invention could consist of any combination or all of the following; a timepiece, cell phone, two-way radio, or wireless Internet device. The Slap on Watch provides a quick and easy method to transport these devices. The Slap on Watch also could be used as a toy for children.

(21) **Appl. No.: 10/079,325**

(22) **Filed: Feb. 20, 2002**

Publication Classification

(51) **Int. Cl.⁷** **A44C 5/00**

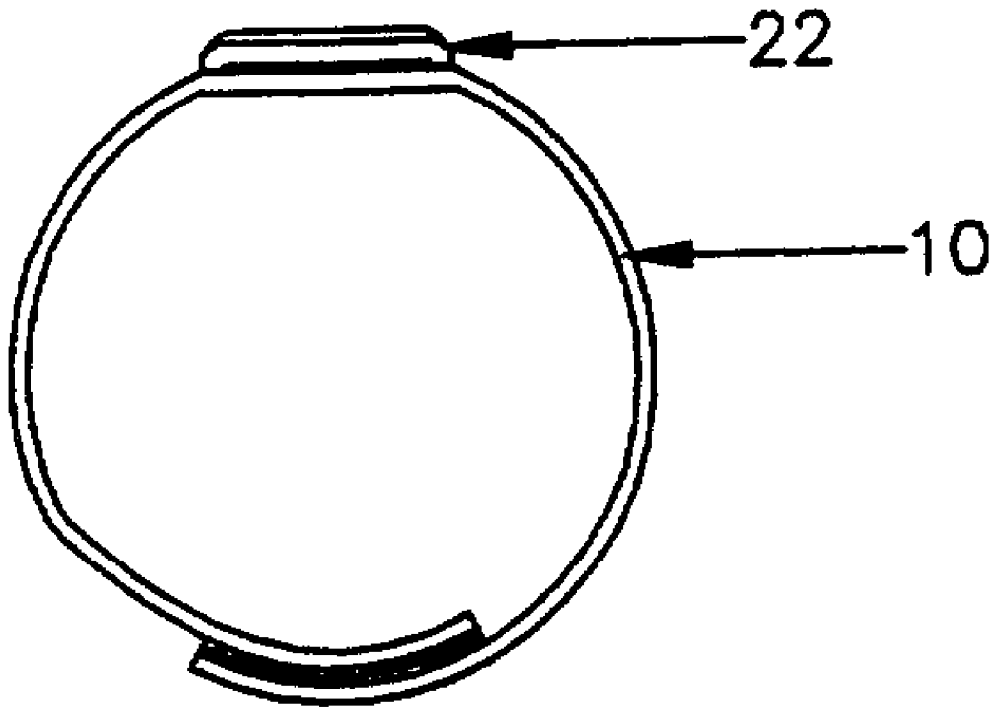

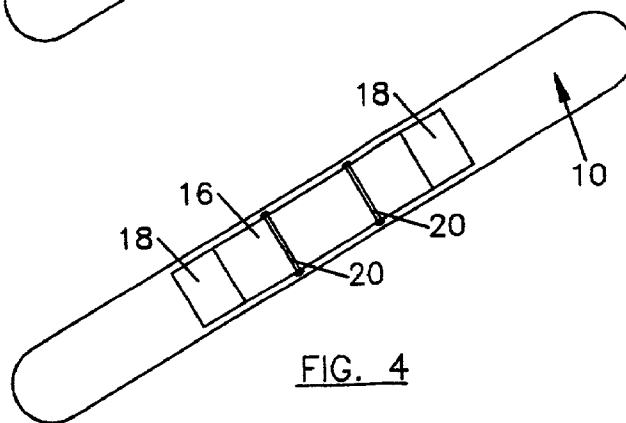
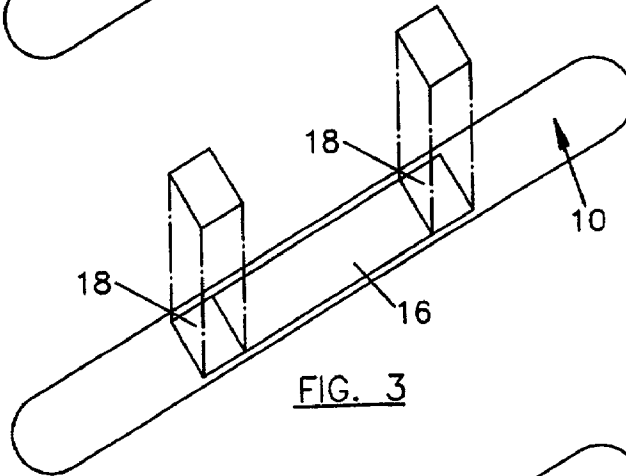
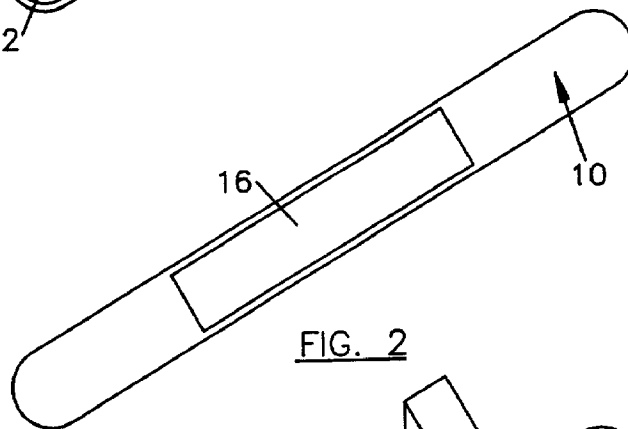
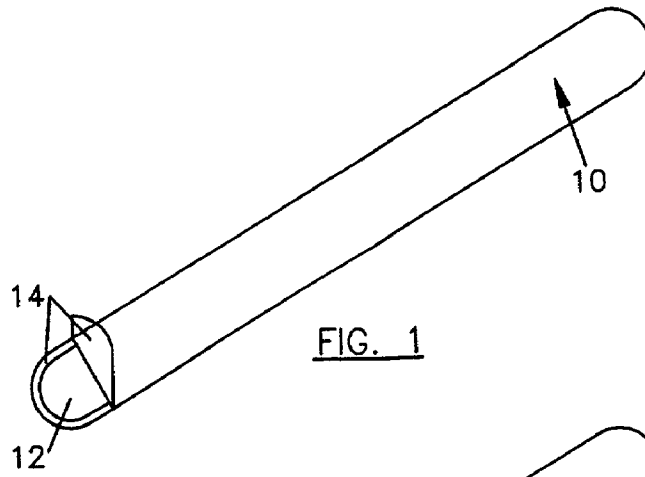

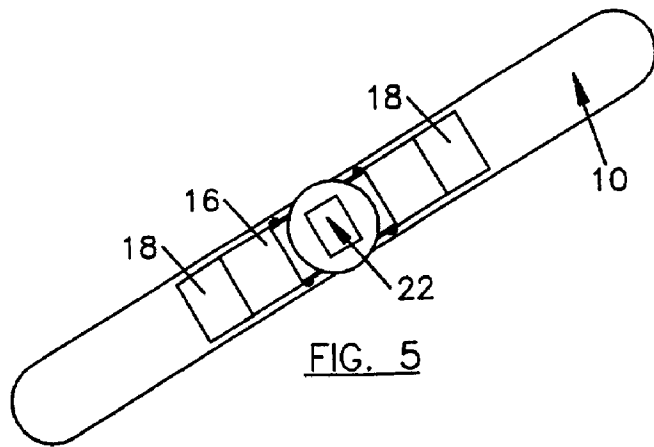

FIG. 5

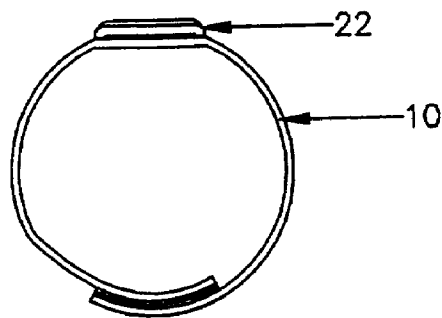

FIG. 6

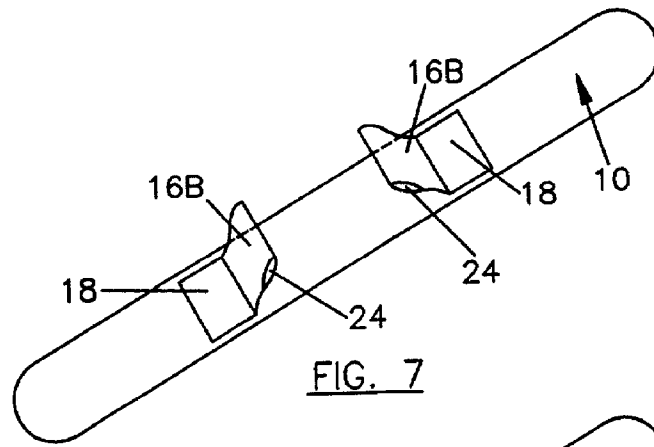

FIG. 7

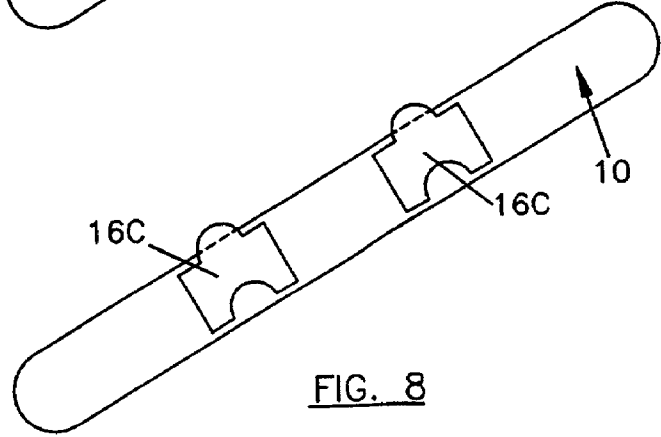

FIG. 8

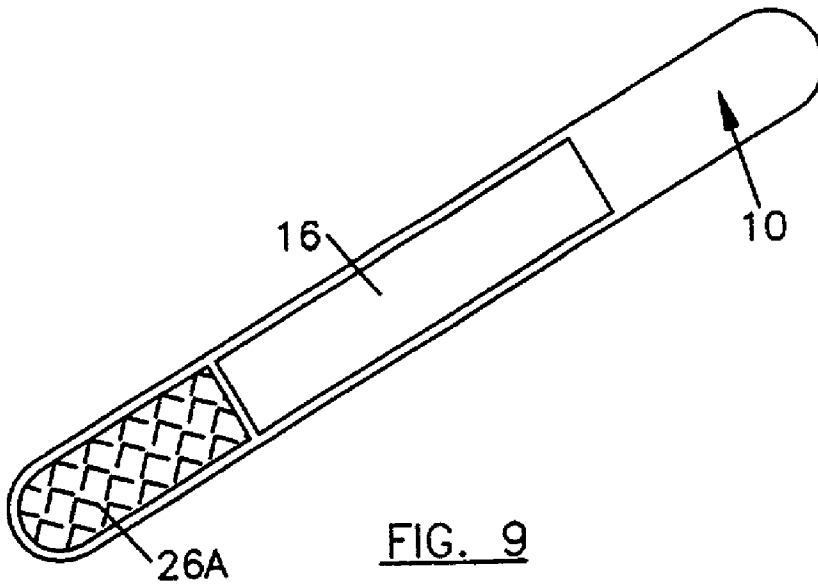

FIG. 9

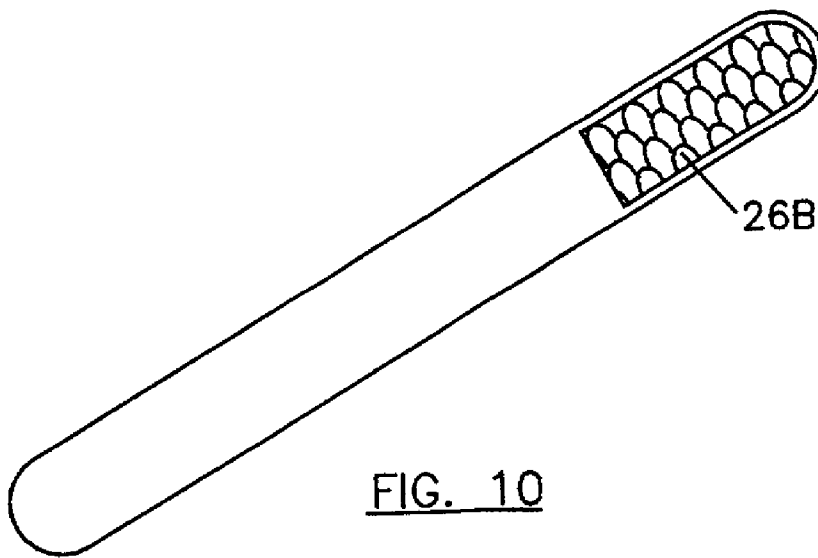

FIG. 10

SLAP ON WATCH**BACKGROUND**

[0001] 1. Field of Invention

[0002] This invention relates to watches or timepieces, specifically to an improved band for quick attachment to a person's wrist.

[0003] 2. Background of the Invention

[0004] Watchbands have been made to try to create a watch that is easy to put on and take off. Previously watchbands have been made in a way that takes time and skill to put on the watch. Inventors have come up with methods to try to ease and quicken this process. U.S. Pat. No. 4,675,955 presents a method in attempt to solve this problem. With this snap buckle method, a person must learn the skill to put on the watch in a timely fashion. Even after the skill is developed, the process still takes a few seconds. The present invention of the Slap on Watch can be put on in a split second. The use of a bistable spring band as a wrist band is known in prior art. The bistable spring band can exist in two states; the straight or elongated state, and the coiled state. These bistable spring bands have been commercially sold under the Trademark SLAP WRAP.TM. The use of the SLAP WRAP.TM is also used in prior art under U.S. Pat. No. 6,220,916 as a toy band with a pre-recorded message. The present invention is an improvement over the SLAP WRAP.TM invention and U.S. Pat. No. 6,220,916 in that it allows the operator to use the bistable spring band to transport a watch or timepiece. The Slap on Watch is also an improvement over U.S. Pat. No. 6,220,916 in that it can provide a permanent attachment for the attached device.

SUMMARY

[0005] The Slap on Watch is a watch that can be secured around the wrist by simply slapping the band against the wrist. The Slap on Watch is a watch that is attached to a slap bracelet. Slap bracelets have been commercially sold under the Trademark SLAP WRAP.TM. When the slap bracelet is slapped against the wrist, it coils and fits to the person's wrist.

OBJECTS AND ADVANTAGES

[0006] Accordingly several objects and advantages of my invention are:

[0007] a) to provide a watch that can be quickly secured around the wrist;

[0008] b) to provide a watch that is easy to secure around the wrist;

[0009] c) to provide a watch that children and senior citizens can put on without trouble;

[0010] d) to provide a watch that is used for a toy and is fun for children;

[0011] e) to provide a watchband for sports watches that can be fastened to the wrist and taken off the wrist quickly;

[0012] f) to provide a futuristic watch that is catchy and classy;

[0013] g) to provide a band for other portable devices such as a cell phone, two way radio, or internet device;

[0014] The Slap on Watch will provide a watch that could be put on in a split second, which is faster than any previous watchbands. Further objects and advantages of my invention will become apparent from a consideration of the drawings and ensuing description.

BRIEF DESCRIPTION OF DRAWINGS:

[0015] **FIG. 1** shows top perspective view of the slap on band.

[0016] **FIG. 2** shows a top perspective view of the slap on band with a piece of elastic material attached to the band creating a watchband.

[0017] **FIG. 3** shows optional extra security fasteners used to attach the elastic material to the band.

[0018] **FIG. 4** shows the watch face pins under the elastic material for attachment of the watch face to the slap on band.

[0019] **FIG. 5** shows a top perspective view of the invention with the watch face attached to the slap on band.

[0020] **FIG. 6** shows a side perspective view of the invention as it would appear when worn around the wrist.

[0021] **FIG. 7** shows an alternative watchband with a different attachment method.

[0022] **FIG. 8** shows another alternative watchband with a different attachment method.

[0023] **FIG. 9** shows a top perspective view of a slap on watchband with Velcro.

[0024] **FIG. 10** shows a bottom perspective view of a slap on watchband with Velcro.

LIST OF REFERENCE NUMERALS

[0025] **10** slap on band

[0026] **12** bistable metal spring body that coils when slapped against the appropriately shaped object.

[0027] **14** material coating for the bistable metal spring body

[0028] **16** elastic material, may be made of rubber or other alternative materials

[0029] **16b** same material as **16** looped to form a hole, one for each watch face pin

[0030] **16c** same material as **16**, two pieces are used instead of one

[0031] **18** securing pieces; preferably fabric, rubber, or plastic

[0032] **20** watch face pins

[0033] **22** watch face (could also be a cell phone, two-way radio, or internet device)

[0034] **24** loop hole formed by looping material **16**

[0035] **26a** Velcro piece

[0036] **26b** Velcro piece that will stick to Velcro piece **26a**

[0037] Description of Invention:

[0038] A preferred embodiment of the invention is shown in FIG. 5 with a watch face or timepiece 22 attached to a slap on band 10. The slap on band 10 is sized in length to fit around and overlap a wrist, forearm or other body part. FIG. 1 shows the construction of a slap on band 10. The slap on band 10 is preferably made of a bistable metal spring body or band 12. Other materials could be used as alternatives to the metal. The bistable metal spring body 12 is concave when facing up as is in FIG. 1. The bistable metal spring body 12 is a bistable spring that has two positions of operation or two states of being. The first state is the elongated position as shown in FIGS. 1, 2, 3, 4, and 5. In this state the bistable metal spring body retains potential energy. This potential energy will cause the band to coil immediately when the bistable metal body 12 is struck against an object such as a person's wrist. The second state is the coiled state as shown in FIG. 6. The coiled shape in FIG. 6 is shown in the form that the bistable metal spring body 12 will take when slapped around a person's wrist.

[0039] The bistable metal spring body 12, when in the elongated position, is typically 6 inches to 12 inches in length, preferably about 9 inches in length. Typically the width of the bistable metal spring body is 0.5 inches to 1.5 inches in width, preferably about 0.975 inches. These dimensions may vary.

[0040] The bistable metal spring body 12 may be coated with a type of material 14 (FIG. 1). The material coating 14 can be made of various types of materials such as fabric, rubber or plastic. It is preferable for the material coating 14 to be water resistant to protect the bistable metal spring body 12 from rusting.

[0041] FIGS. 2, 3, and 4 show a preferable attachment method for attaching the watch face 22 to the slap on band 10. FIG. 2 shows a thin piece of material 16 which is attached to the slap on band 10. This material 16 is preferably elastic. The elastic material 16 is attached to the top or concave side of slap on band 10, at both ends of the elastic material 16, leaving the center of the elastic 16 unattached to the concave surface of the slap on band 10. The elastic material 16 can be attached using an adhesive or by fusing the elastic 16 to the slap on band 10. Other methods for attaching the elastic may also be used. The dimensions of the elastic 16 may vary. It is preferable for the width to near the edge of the slap on band 10. The length of the elastic 16 will vary depending on the size of the watch, but must be short enough to fit on the slap on band 10.

[0042] FIG. 3 shows optional securing pieces 18 used to secure the attachment of the elastic 16 to the slap on band 10. The securing pieces are shaped to cover the two ends of the elastic material 16. The securing pieces 18 are preferably positioned to overlap the elastic 16 and can be attached to the slap on band 10 by using an adhesive, fusing the securing pieces 18 to the elastic 16 and slap on band 10, or other methods for attachment.

[0043] FIG. 4 shows the elastic material 16 being stretched away from the slap on band 10 to position the watch face pins 20 under the elastic 16. While the pins 20 are under the elastic material 16 the pins 20 are inserted into the watch face 22. Once the pins 20 are inserted into the watch face 22, the watch is securely attached to the slap on band

10, forming the invention of a Slap on Watch. The watch face 22 would not have to have watch pins in order to attach it to the elastic piece 16. The elastic 16 could slide through a watch face that had holes for the elastic to slide through.

[0044] Operation of Invention:

[0045] The Slap on Watch invention is attached to the wrist by slapping the watch with the slap on band 10 in the elongated position against a person's wrist or other object on which one may wish to attach the watch. The slap on band 10 will then coil and fit to the person's wrist in the form seen in FIG. 6, securing the Slap on Watch around the wearer's wrist.

[0046] Alternative Embodiments:

[0047] FIGS. 7 and 8 show alternative attachment methods used to secure the watch face 22 to the slap on band 10. FIG. 7 shows two pieces of material 16b being used to form loop holes 24 for inserting the watch face pins 20. The elastic material 16 can be fastened in the same manner as described in the preferred embodiment and may use the optional securing pieces 18. FIG. 8 shows two pieces of material 16c each individually attached to the slap on band 10 in the same manner as stated in the preferred embodiment description. One watch face pin 20 will go under each piece of material 16c to attach the watch face 20 to the slap on band 10.

[0048] Another method for attachment not shown in the drawings is an attachment in which the watch face 22 could easily be fastened and removed from the slap on band 10. This would create a watch face 22 that would be interchangeable between many slap on bands 10. These are just a few of the many alternative methods for attaching the watch face 22 to the slap on band 10. This invention is not limited to these methods, but uses these methods as suggested methods for attachment.

[0049] It is yet another alternative embodiment to use a cell phone, two-way radio, or a wireless internet device in place of or in addition to the watch face 22. The cell phone, two-way radio, or Internet device could be part of the watch face 22, in place of the watch face 22, or used in any combination of these devices.

[0050] FIGS. 9 and 10 show an optional accessory to the slap on band 10. FIG. 9 shows the top of the slap on band 10 with a Velcro piece 26a attached above the elastic material 16 to the slap on band 10. FIG. 10 shows the bottom of the slap on band 10 with a Velcro piece 26b attached at the opposite end of Velcro piece 26a, to the slap on band 10. These Velcro pieces 26 must be separate kinds of material so that the two Velcro pieces 26 stick to each other. When the slap on band 10 has the Velcro pieces 26 attached, the Velcro pieces will stick together when the slap on band 10 is in the coiled position shown in FIG. 6. This will allow the Slap on Watch to be fastened more securely to the human wrist.

[0051] Advantages:

[0052] The described Slap on Watch provides a watch that is easy and fast to put on and take off for all watch wearers. It could be used as a talking watch for senior citizens who cannot see clearly. It could be used as a toy for children. The Slap on Watch could be used as a sports watch. The Slap on Watch could be used as a way to transport a cell phone,

two-way radio or internet device along with the human body. There may also be other advantages that become apparent to someone skilled in this field.

[0053] Conclusion, Ramifications, and Scope:

[0054] Accordingly, the reader can see that the Slap on Watch provides a convenient method for securing a watch or other device to the human body. The Slap on Watch provides a watchband that could be the next wave of the future in the watch industry.

[0055] While my above description contains many specifications, these should not be construed as limitations on the scope of the invention but as merely providing illustrations of some of the presently preferred embodiments of this invention. Many other variations are possible. For example, the dimensions for the bistable metal spring body **12** could vary further from the specified dimensions. Also, the material coating **14** could vary further from the suggested materials. This material coating **14** could be made of just about anything, as long as it serves the purpose of protecting the human skin from the sharpness of the bistable metal spring body **12**. The method for attaching the watch face **22** to the slap on band **10** could vary because there could be an infinite number of ways to attach these two objects.

[0056] If the preferred embodiment of the invention is used as described in the specification, the size and shape of the elastic material **16** could vary. The type of material that is used could also vary because this material would not have to be elastic, although it is preferred. There are many alternative methods for attaching the elastic material **16**. The size, shape and material used for the securing pieces **18** could also vary.

[0057] Accordingly, the scope of the invention should be determined not by the embodiments illustrated, but by the appended claims and their legal equivalents.

I claim:

1. A Slap on Watch comprising:

a bistable spring body sized in length to coil around a limb of a human being or appropriately shaped object, and having two states, straight or coiled; and

one or any combination of devices selected from the group consisting of a watch face, cellular phone, two-way radio, or wireless Internet device; attached to said bistable spring body, whereby said bistable spring body can be secured around the human limb or appropriately shaped object by slapping said bistable spring body in the straight state against the human limb causing said bistable spring body to coil and form to said human limb.

2. The Slap on Watch of claim 1 wherein the said device is permanently attached to said bistable spring body.

3. The Slap on Watch of claim 1 wherein said bistable spring body comprises a metal spring body.

4. The Slap on Watch of claim 1 wherein said bistable spring body comprises a material coating.

5. A Slap on Watchband comprising:

a bistable spring body sized in length to coil around a limb of a human being or appropriately shaped object, and having two states, straight or coiled; and

a means for attaching one or any combination of devices selected from the group consisting of a watch face, cellular phone, two-way radio, or wireless Internet device.

6. The Slap on Watchband of claim 5 wherein said bistable spring body comprises a metal spring body.

7. The Slap on Watchband of claim 6 wherein said bistable metal spring body is covered with a material coating.

8. The Slap on Watchband of claim 6 wherein said bistable metal spring body is coated with a water resistant material.

9. The Slap on Watchband of claim 5 wherein said attaching method comprises a piece of material secured at opposite ends of said material to the upward facing side of said bistable spring body, whereby the approximate center portion of said material is unattached, leaving a space where watch pins or other fastening pieces could be placed between said material and said bistable spring body to secure one or any combination of devices selected from the group consisting of a watch face, cellular phone, two-way radio, or wireless Internet device to said bistable spring body.

10. The Slap on Watchband of claim 5 wherein said attaching method comprises two pieces of material looped and secured to said bistable spring body forming holes for said watch pins to be inserted.

11. The Slap on Watchband of claim 5 wherein said attaching method comprises two pieces of material, each secured to said bistable spring body at both ends of said material providing a gap for one watch pin to be inserted under each piece of material between said bistable spring body and said material.

12. The Slap on Watchband of claim 5 wherein Velcro is attached at opposite ends and opposite sides of the said slap on watchband creating a watchband wherein the two ends of the said slap on watchband will fasten together after it is slapped against the wrist.

13. In combination:

one or any combination of devices selected from the group consisting of a watch face, cellular phone, two-way radio, or wireless Internet device; and

a means for attaching the said device to a bistable spring body existing in two states, straight and coiled; whereby said bistable spring body can be secured around a human limb or appropriately shaped object by slapping said bistable spring body against the said human limb.

* * * * *