



US00D638454S

(12) **United States Design Patent**  
**Torii et al.**

(10) **Patent No.:** **US D638,454 S**

(45) **Date of Patent:** **\*\* May 24, 2011**

(54) **ROTARY ACTUATOR**

(75) Inventors: **Nobutaka Torii**, Tsukubamirai (JP);  
**Naoki Kurosawa**, Tsukubamirai (JP)

(73) Assignee: **SMC Corporation**, Chiyoda-ku, Tokyo  
(JP)

(\*\*) Term: **14 Years**

(21) Appl. No.: **29/384,024**

(22) Filed: **Jan. 26, 2011**

(51) **LOC (9) Cl.** ..... **15-09**

(52) **U.S. Cl.** ..... **D15/143**

(58) **Field of Classification Search** ..... D13/158,  
D13/162, 184; D15/5, 7, 9, 143, 148, 199;  
74/89.15, 411.5, 490.09; 297/14, 325, 327;  
310/10, 12, 15, 20, 80, 300

See application file for complete search history.

(56) **References Cited**

**U.S. PATENT DOCUMENTS**

D239,319	S	*	3/1976	Matousek	.....	D15/148
D304,834	S	*	11/1989	Habicht	.....	D15/148
D313,650	S	*	1/1991	Odegaard	.....	D23/386
6,603,229	B1	*	8/2003	Toye, IV	.....	310/90
D479,541	S	*	9/2003	Lannoch	.....	D15/148
6,932,319	B2	*	8/2005	Kowalski	.....	251/129.11

D540,348	S	*	4/2007	Chu	.....	D15/7
D541,816	S	*	5/2007	Puls	.....	D15/7
2010/0060091	A1	*	3/2010	Nordgren	.....	310/80

\* cited by examiner

*Primary Examiner* — Patricia Palasik

(74) *Attorney, Agent, or Firm* — Yokoi & Co., U.S.A., Inc.;  
Toshiyuki Yokoi

(57) **CLAIM**

The ornamental design for a rotary actuator, as shown and described.

**DESCRIPTION**

FIG. 1 shows a front view of a rotary actuator showing my new design;

FIG. 2 shows a rear view thereof;

FIG. 3 shows a right side view thereof;

FIG. 4 shows a left side view thereof;

FIG. 5 shows a top view thereof;

FIG. 6 shows a bottom view thereof;

FIG. 7 shows a top, front and right side perspective view thereof; and,

FIG. 8 shows a bottom, rear and left side perspective view thereof.

The portions of the design shown in broken lines in FIGS. 1 and 5-8 are for the purpose of illustrating the environment only and form no part of the claimed design.

**1 Claim, 4 Drawing Sheets**

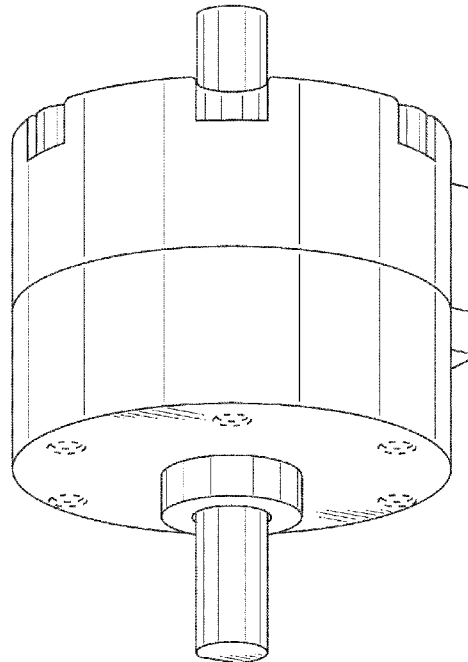
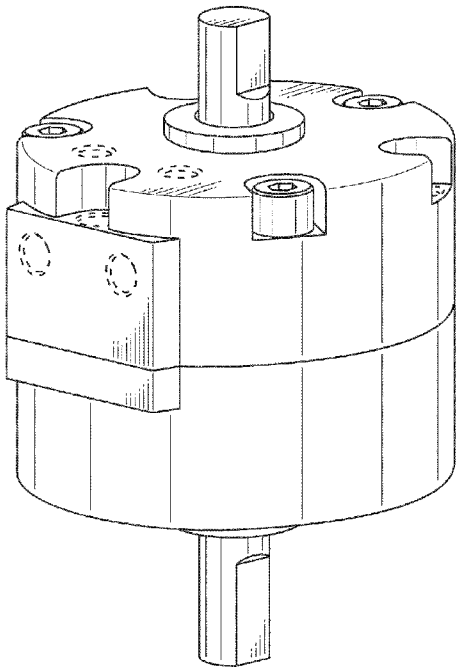

FIG. 1

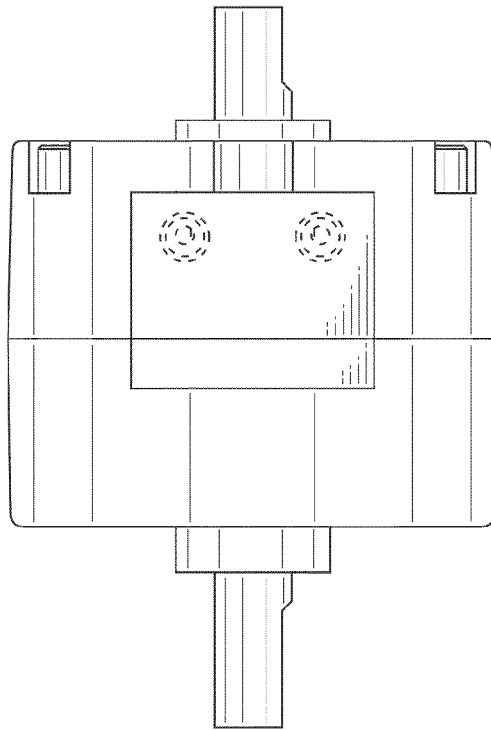

FIG. 2

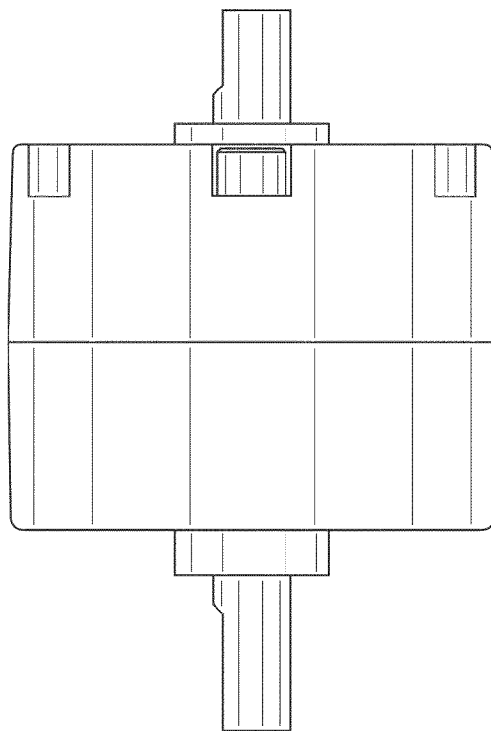

FIG. 3

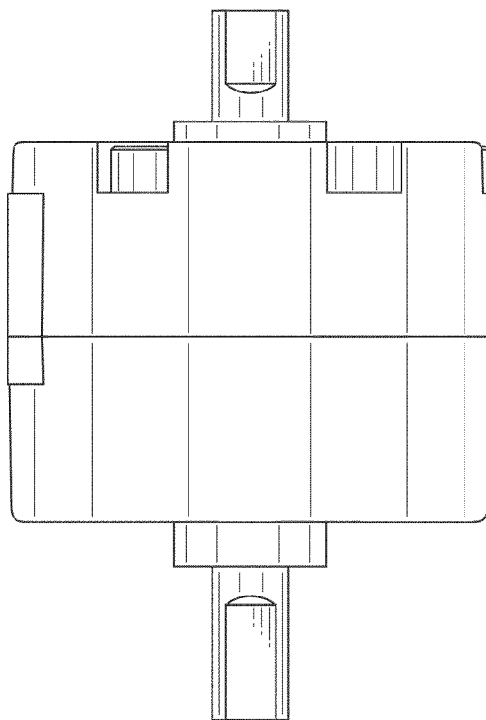

FIG. 4

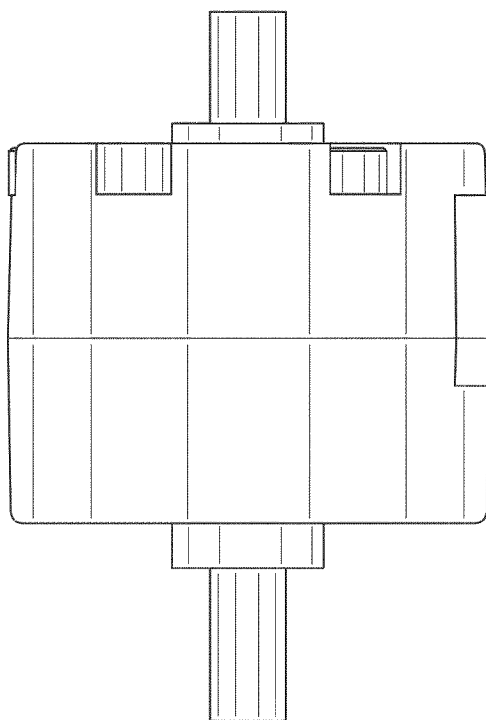

FIG. 5

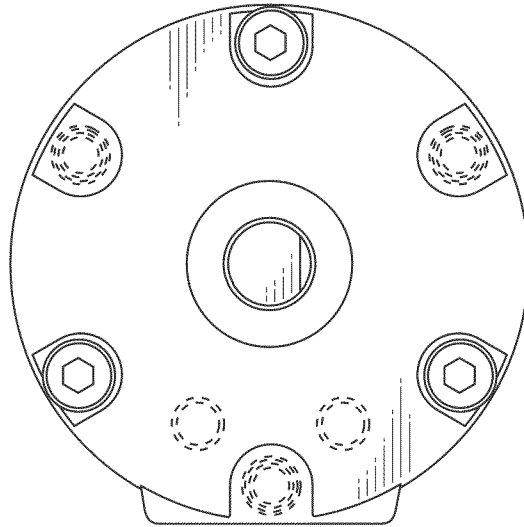

FIG. 6

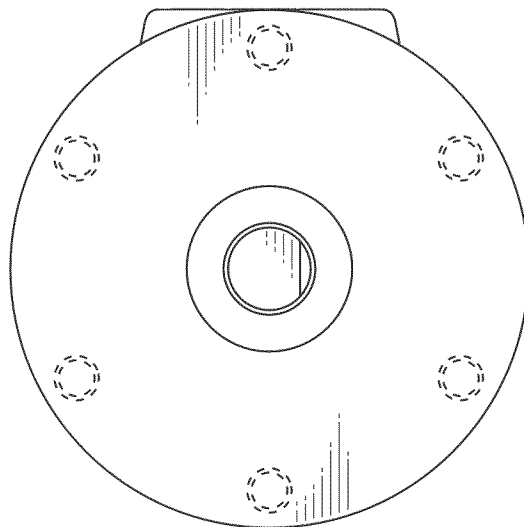

FIG. 7

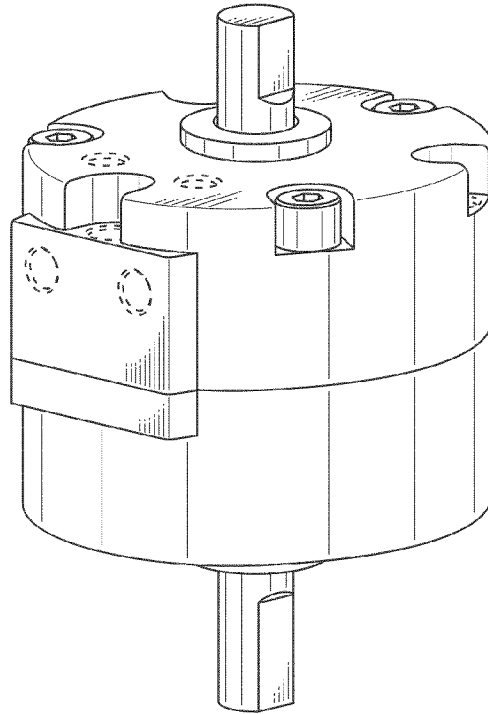

FIG. 8

