

D. N. B. COFFIN, Jr. Steering Apparatus.

No. 156,695.

Patented Nov. 10, 1874.

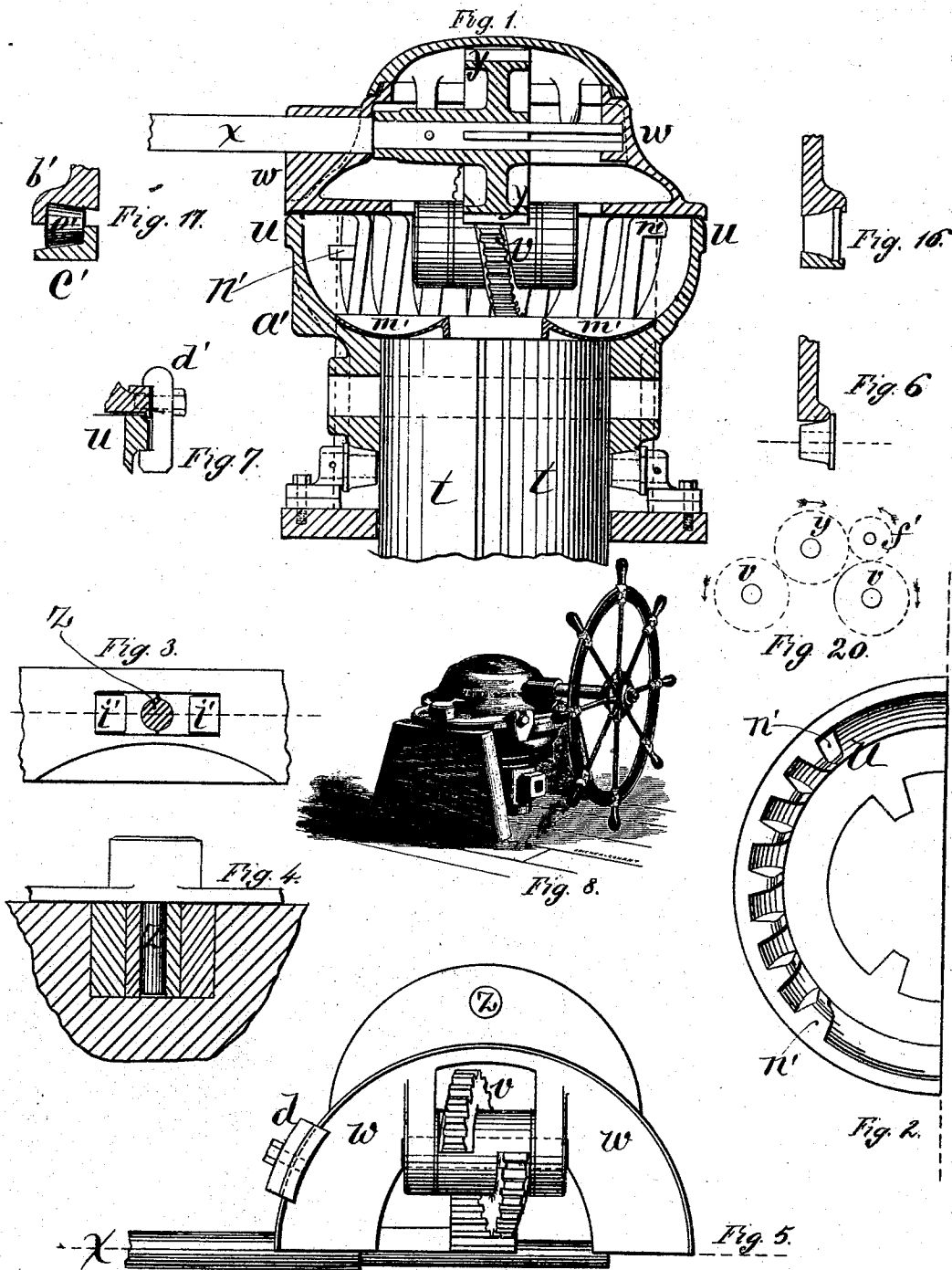

Witnesses.

Frank R. Rogers
Benj. Woodward

Inventor.

David N. B. Coffin, Jr.

D. N. B. COFFIN, Jr.
Steering Apparatus.

No. 156,695.

Patented Nov. 10, 1874.

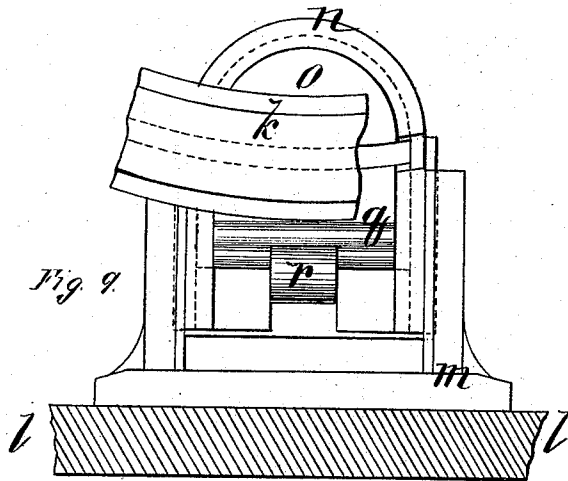

Fig. 9.

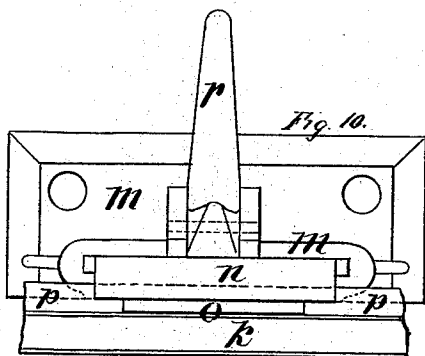

Fig. 10.

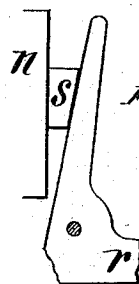

Fig. 12.

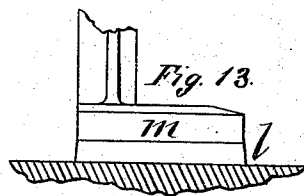

Fig. 13.

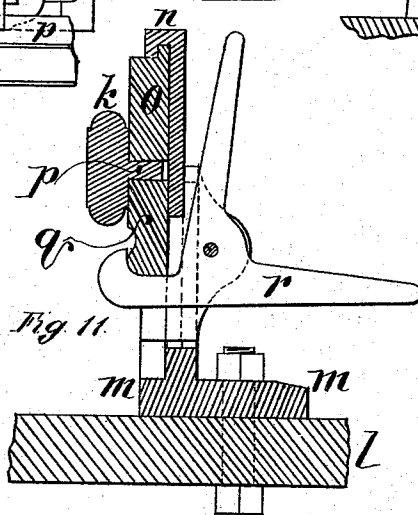

Fig. 11.

Witnesses.
 Frank R. Rogers.
 Ben^o Woodward

Inventor.

David N. B. Coffin, Jr.

D. N. B. COFFIN, Jr.
Steering Apparatus.

No. 156,695.

Patented Nov. 10, 1874.

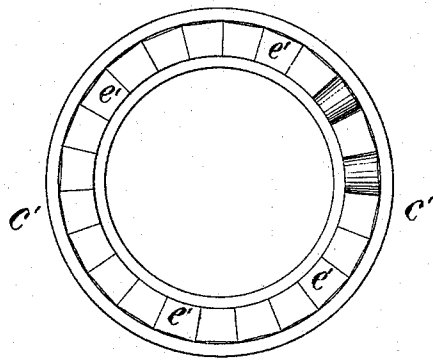

Fig. 18.

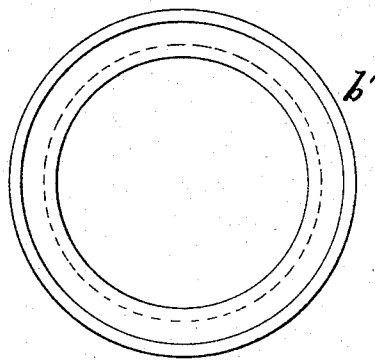

Fig. 19.

Witnesses
Frank H. Rogers
Benjamin Woodward

Inventor
David N. B. Coffin Jr.

UNITED STATES PATENT OFFICE.

DAVID N. B. COFFIN, JR., OF NEWTON, MASSACHUSETTS.

IMPROVEMENT IN STEERING APPARATUS.

Specification forming part of Letters Patent No. 156,695, dated November 10, 1874; application filed February 5, 1874.

To all whom it may concern:

Be it known that I, DAVID N. B. COFFIN, JR., of Newton, in the county of Middlesex and State of Massachusetts, have invented Improvements in Steering Apparatus, of which the following is a specification:

These improvements are illustrated in the accompanying drawings, of which Figure 1 represents a sectional view of a screw-steerer, the section-plane coinciding with the axes of the wheel-shaft *x* and rudder-stock *t*. Fig. 2 is a plan of half the rudder-head *u*. Fig. 3 is a plan of one of the supports for the apparatus, showing mortise containing one trunnion and two gibs, and two elastic cushions or springs, *v*. Fig. 4 is a sectional elevation of same and part of steerer, from which the trunnion projects downward. Fig. 5 is an under view of the part carrying the screws, wheel-shaft trunnions *z* and *c*. Fig. 6 illustrates the conical rollers acting under the rudder-head, or a rim for the purpose. These rollers are shown in Fig. 1. They also act as concentric guides. Fig. 7 is a view of the clasps used to prevent the steerer separating or lifting up from its hold upon the rudder-head. Fig. 8 is a perspective view of the screw-steerer complete. Fig. 9 is an elevation of a section, *k*, of a steering-wheel, and a device grasping a concentric projecting rim, *p*, the device to be operated by the foot, to check or stop the motion of the wheel. Fig. 10 is a plan of the same; Fig. 11, a sectional view at right angles with the first or Fig. 9. Fig. 12 is a view showing how the wheel may be set by forcing a block, *s*, between the upwardly-projecting arm of the foot-lever and the back of the stand. Fig. 13 shows the device adjusted to the proper height to accommodate the elevation of the wheel by means of a wood or other seat fitted under it upon the deck *l*.

In Figs. 9, 10, 11, 12, and 13, *k* is the steering-wheel, a portion of its rim only being shown. *l* is the vessel's deck; *m*, a stationary stand. *n* is a sliding jaw. *o* is an oscillating die, adjusting itself to the ledge or rim *p*, attached to or formed on the wheel *k*. *q* is the lower die, and *r* is a foot-lever pivoted to sliding jaw *n*, and is operated by the foot to force upward the lower die *q*, thereby to gripe and produce friction upon the rim *p*, thereby to check or

stop the movement of the wheel. When it is required to keep the friction on, the block *s* is forced between the upwardly-projecting arm of lever *r* and the jaw *n* or stand. When the operator's foot is lifted or the block *s* removed, the wheel is free to revolve.

Figs. 1, 2, 3, 4, 5, 6, 7, 8 illustrate a screw-steerer, *t* being the rudder-stock; *u*, the rudder-head, showing the teeth or nut formation into which the two screws *v v* play, for the purpose of giving it motion. *w* is a frame or main piece, carrying the worms *v v* and the wheel-shaft *x*. On the wheel-shaft *x* is the pinion or gear *y*, made with width of face enough to span the length of the worm or screw *v*, in the thread of which are formed corresponding teeth, into which the teeth of gear *y* are made to mesh, for the purpose of giving motion to the screws *v v*. The frame or part *w* is provided with the trunnions *z*, and rests upon the supports shown in Figs. 1, 3, and 4. These supports are provided with mortise, (see Figs. 3 and 4,) the trunnions *z* projecting downward in the center, an iron or other gib on either side, with a substantial elastic cushion of rubber or other material at each end of the mortise, to resist the tendency of the frame to revolve with the rudder, and also thereby to relieve the dangerous effect of surges upon the rudder in a rough sea, and under other strains. Clasps *d'*, (shown in Figs. 7 and 5) serve to prevent any lifting of part *w* away from the rudder-head, but, as will be seen, all may lift together, and safely, when, by grounding or other casualty, the rudder is lifted out of its proper position. An annular oil-pan, *m'*, is shown in Fig. 1, beneath the screws *v*, and into which they constantly dip. The pan being provided with plenty of suitable oil, the screws will keep themselves constantly oiled. Anti-friction washers are usually provided at each end of the screws to take the thrust.

In Figs. 1, 6, 16, and 17 are shown conical roller-supporters for the rudder-head, keeping it always in proper adjustment to the actuating mechanism of the steerer.

The construction shown in Figs. 1 and 6 and 17 is such that the water will flow freely away, so as not to freeze up in a position to obstruct the working of the rollers. The rudder-head may be formed to bear on these roll-

ers or a separate collar in one part, or several parts bolted together may be applied for the purpose. The series of rolls of Fig. 17 extend entirely around the rudder-stock.

When it is desirable to make both screws' threads wind in the same direction, and avoid the opposite or right-and-left construction of the screws, and to have a uniform gear or nut formation all around within the rudder-head, it is only necessary to add an intermediate gear, f' , as indicated in Fig. 20.

If any need should ever occur by wear or otherwise to tighten the fit of the screw-thread in the rudder-head, it may be done by putting in new screws with thicker threads; or the screws may be made in two parts, the division occurring in coincidence with radial lines drawn from the middle of the screw-thread at its periphery perpendicularly to their axis; then, as they wear, the two parts may be forced apart by a screw, wedge, or a packing interposed between the two parts.

Figs. 18 and 19 further illustrate the roller-guide for rudder-head, which has been referred to in connection with Fig. 17. Fig. 18 is a plan of rolls and track c' , and Fig. 19 an under view of ring-cap b' . The cap-ring b' may be formed on the rudder-band.

For the purpose of steering in the forward part of the vessel a wheel may be erected there, and provided with a chain-wheel and shaft, and a chain-belt, to connect with a line of shafting on or under the deck, extending aft to the steerer, this shaft similarly to be provided with a chain-wheel and chain-belt, connecting it to the steerer-wheel shaft, on which in that case a chain-wheel should also be placed. Or the longitudinal shafting may be connected to both steering-wheel shafts by means of upright or inclined shafts, and the

proper bevel or miter gear wheels, or by a train of spur-gear wheels.

A tell-tale or pointer is attached immediately to or cast upon the rudder-head, as see a' , Fig. 1, also shown in Fig. 8, to indicate the position of the rudder.

With reference to the rolls e' of Figs. 17 and 18, and their circular or annular track c' and cap b' , I will further explain that they guide the rudder-head concentrically, as well as support it vertically, or in the direction of its axis, the outer flange on cap b' acting on the outer ends of the rolls e' , and their inner ends acting against the inner flange of track c' .

I claim—

1. The toothed screws, in combination with the rudder-head and steering-wheel of a steering apparatus.

2. The downwardly-projecting trunnions z , attached to the frame w , in combination with the spring-cushions i , and the mortise inclosing them beneath, substantially as set forth.

3. The combination of the wheel-shaft gear, the two screws v , and their worms in the rudder-head, substantially as described.

4. The stops n' (shown in Figs. 1 and 2) at each end of the travel of the worm v , for its thread to stop against, substantially as shown.

5. The conical roll e' , (shown in Fig. 17,) in combination with the band b' , rudder-stock, and track c' , substantially as shown.

6. The friction device $o q r n$, in combination with the steering-wheel k , substantially as described.

DAVID N. B. COFFIN, JR.

Witnesses:

L. BURNETT,
FRANK K. ROGERS,
BENJN. WOODWARD.