

(12) UK Patent Application (19) GB (11) 2 300 491 (13) A

(43) Date of A Publication 06.11.1996

(21) Application No 9609250.7  
(22) Date of Filing 02.05.1996  
(30) Priority Data  
(31) 9505270 (32) 03.05.1995 (33) FR

(51) INT CL<sup>6</sup>  
G02B 6/36  
(52) UK CL (Edition O )  
G2J JGEA JG10 JG3  
U1S S2316

(71) Applicant(s)  
Alcatel Submarcom  
  
(Incorporated in France)  
  
30 rue des Chasses, 92110 Clichy, France

(56) Documents Cited  
GB 2229545 A GB 2165661 A EP 0595395 A1  
US 5341451 A US 5119459 A US 4502754 A  
US 4428645 A

(72) Inventor(s)  
Jean-Francois Libert  
Bruno Daguét  
Romuald Lemaitre  
Francois Mesnil

(58) Field of Search  
UK CL (Edition O ) G2J JGEA  
INT CL<sup>6</sup> G02B

(74) Agent and/or Address for Service  
Haseltine Lake & Co  
Hazlitt House, 28 Southampton Buildings, Chancery  
Lane, LONDON, WC2A 1AT, United Kingdom

(54) Optical fibre cable organiser

(57) An optical fiber cable connection organizer device 2 includes a support assembly with lateral accessways for the fibers of the cables 1A,1B, an arrangement for holding splices between the fibers and an arrangement for stowing a surplus length of the jointed fibers on top plate 40. It further comprises two sets of magazines 30 for stowing additional slack in the fibers from the two cables on bottom plate 20. Applications include submarine optical fiber cable joint boxes.

Shrinkable sleeves 6A, 6B are shown.

FIG.1

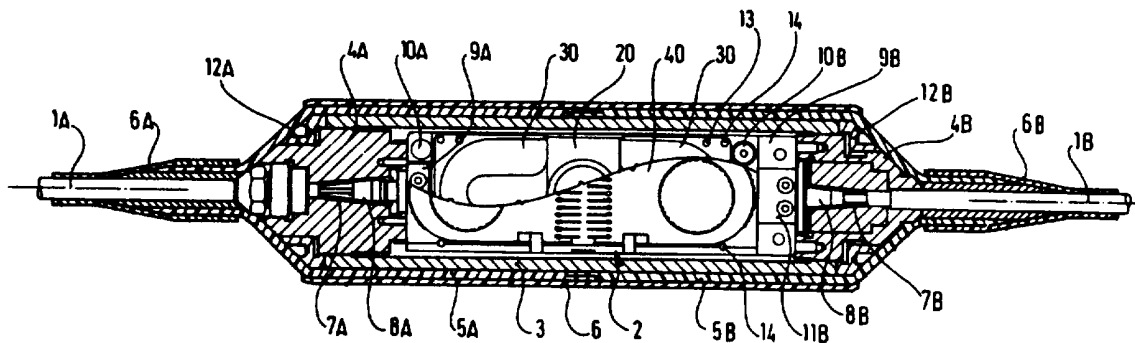

GB 2 300 491 A

FIG.1

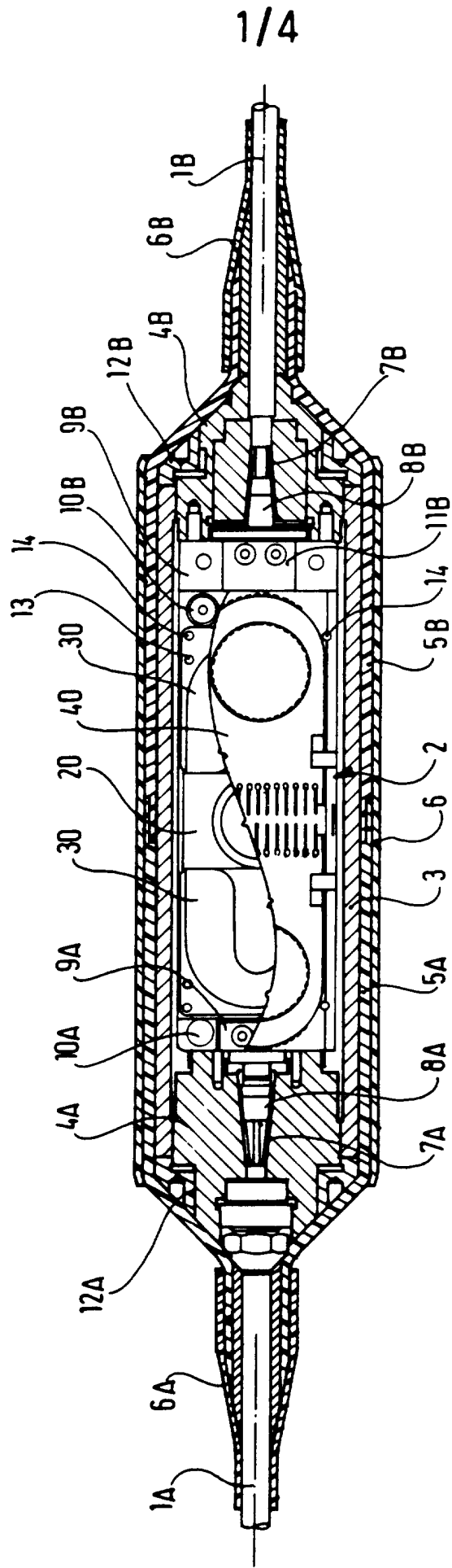



FIG. 5

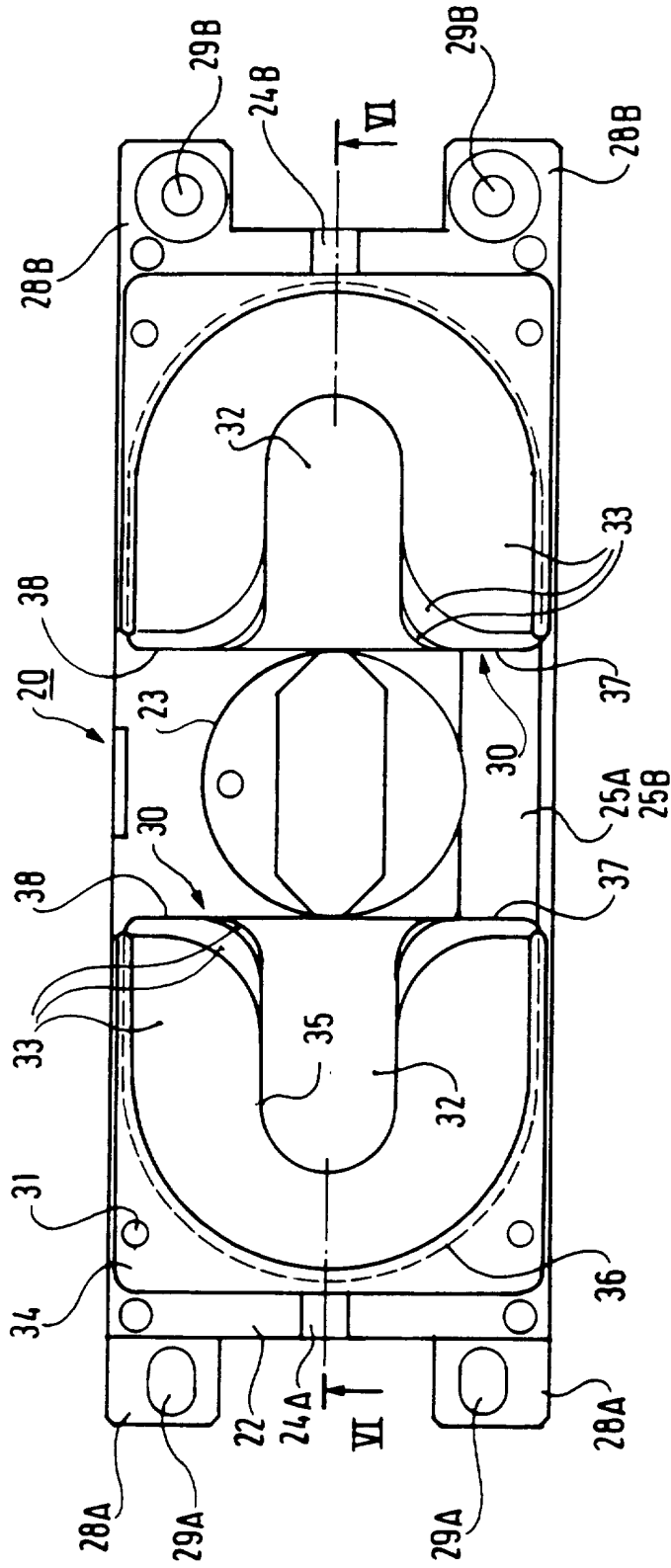

FIG. 6

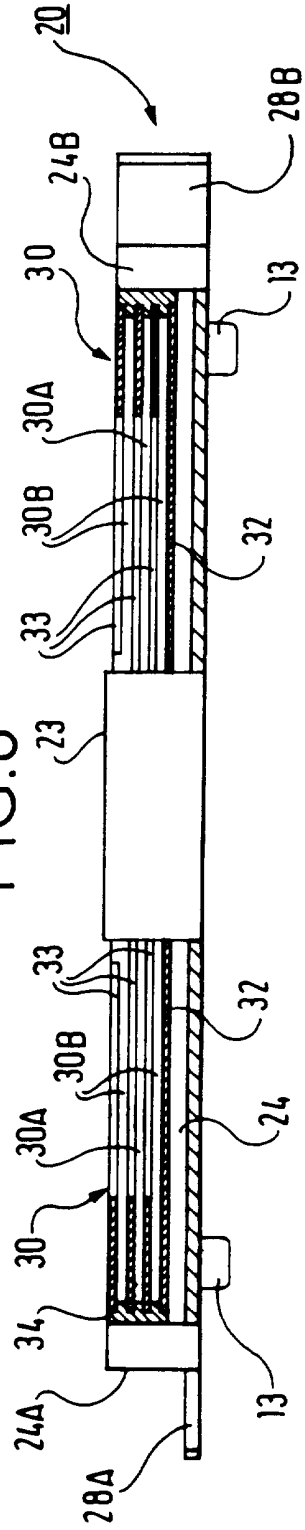

FIG. 10

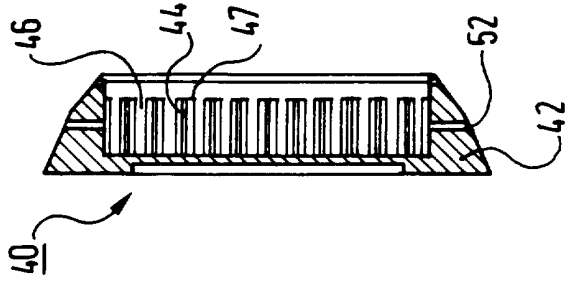

FIG. 7

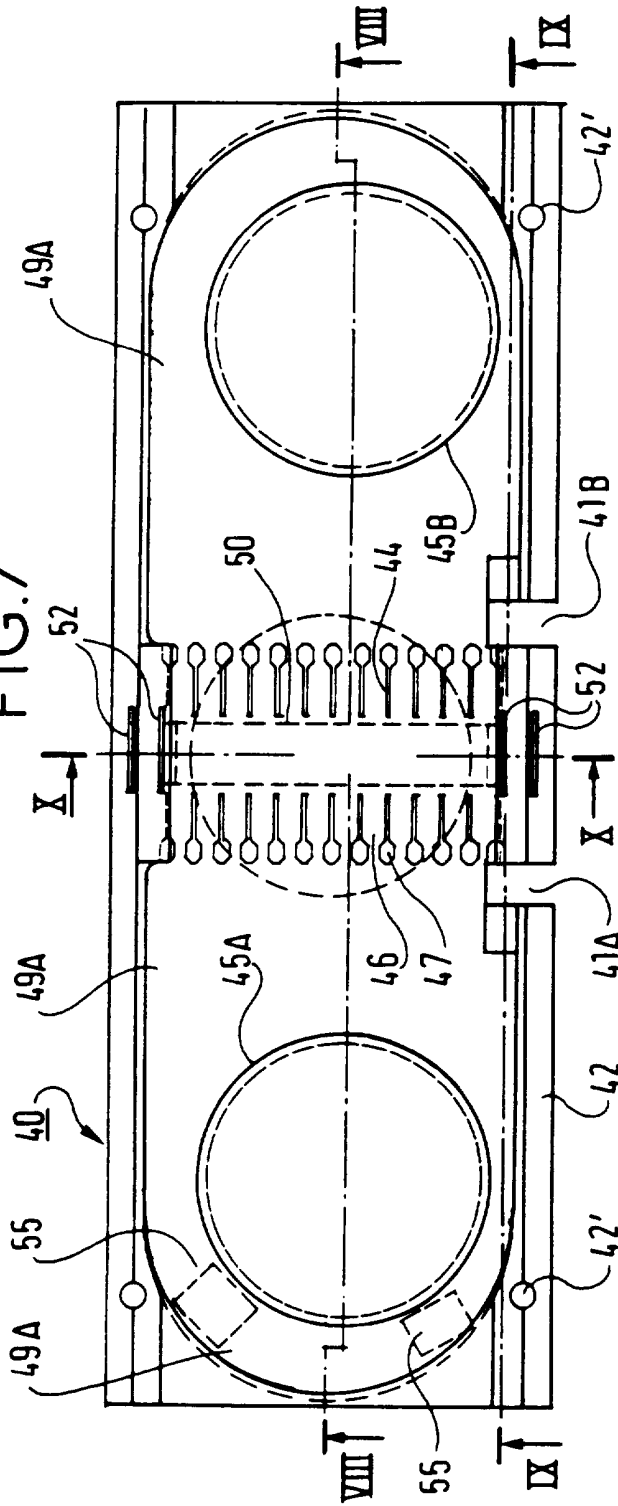

FIG. 8

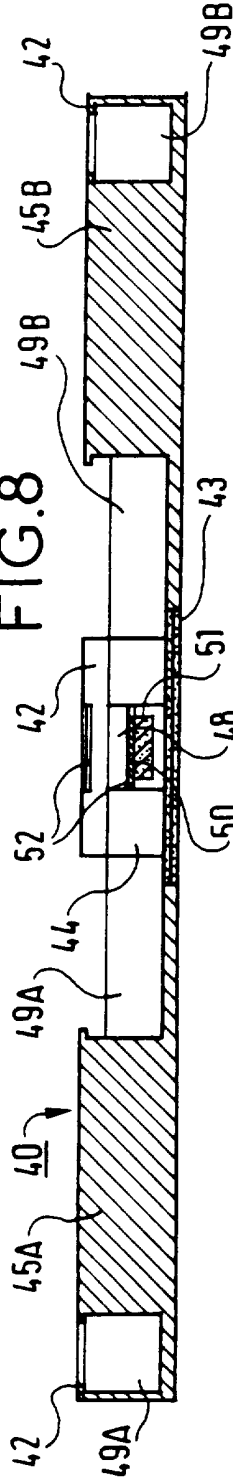
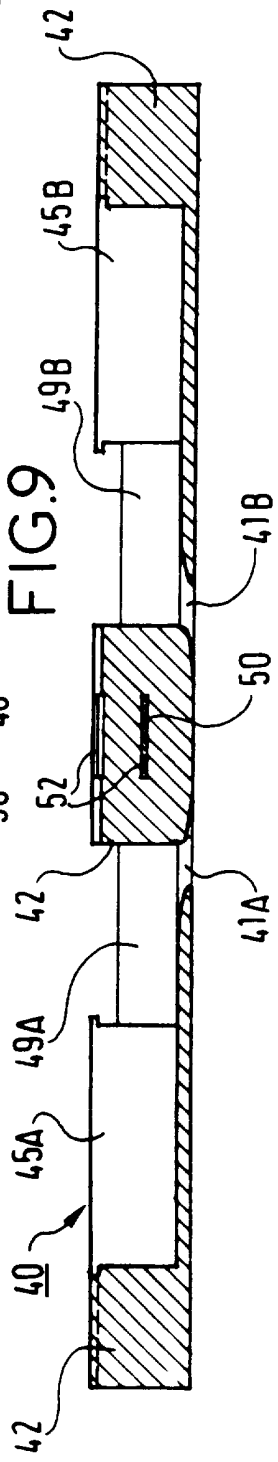

FIG. 9



DEVICE FOR ORGANIZING OPTICAL FIBER CABLE CONNECTIONS  
AND OPTICAL CABLE JOINT BOX

BACKGROUND OF THE INVENTION

Field of the invention

5           The present invention concerns the jointing of optical fiber cables, in particular submarine optical fiber cables. It is more particularly concerned with a device for organizing optical fiber cable connections and an optical cable joint box.

10           Optical fiber cables usually comprise a set of optical fibers, possibly mounted on a grooved rod or in a protection tube filled with a gel or possibly embedded in a binding polymer with one or more carrier and/or strength members associated with the fibers. Submarine  
15           optical cables also include at least one layer of external armoring and electrically conductive remote power feed means, if necessary. Terrestrial optical cables often include wires for tensile strength  
20           integrated into or surrounding the optical part. Optical fiber cables are covered with a sheath to protect and possibly insulate them from the seawater.

          To joint two optical fiber cables, the set of fibers or the optical part of each cable is freed from the structure of the cable over a certain length of the  
25           end portion of the cable so that the fibers of the two cables can be spliced.

Description of the prior art

          Application EP-A-0 274 060 describes a joint box for optical fiber cables, in particular submarine cables.  
30           The box includes a container tube with the ends closed by two covers with bores in them and an interior cylindrical tank in which the jointed fibers are stowed. The tank is fixed between the covers. The cables are anchored into the covers and their fibers extend into the tank through  
35           a narrow passage provided in each cover. The tank has a

wide central opening through which the fibers to be  
jointed can be extracted and then re-inserted into the  
tank. Its lower wall, which is cylindrical in the middle  
part of the tank, ends in a tulip-shape portion to  
5 receive the fibers passing through each cover. It also  
has two annular interior recesses, where each end part  
joins the middle part of the tank, in which surplus  
lengths of the jointed fibers are stowed in coils against  
the bottom of the recesses.

10 The storage tank does not include any means for  
holding the splices, which must have good mechanical  
strength since there is no external reinforcement to  
protect them and they are loose in the storage tank. The  
lack of holding means for the splices in the tank is  
15 incompatible with mechanical reinforcement of the splices  
because their weight becomes large in comparison with the  
stiffness of the fibers. Mechanically reinforced splices  
are often preferred over unreinforced splices for  
practical reasons.

20 Document US-A-4 840 449 describes a device for  
organizing the connections between two optical fiber  
cables. This device includes a rectangular support  
having on one face a rib along each of its shorter sides,  
two cylinders onto which the fibers are coiled provided  
25 side by side along one of its longer sides and means for  
holding the splices between the fibers along the other  
longer side. The two cylinders are spaced from each  
other and from the rib adjacent each of them. The cables  
are fixed to the support near the accessways provided for  
30 the fibers on the support, the splices between the fibers  
are effected, the splices are positioned in the holding  
means and the surplus length of the fibers from the  
cables is stowed in coils around both the cylinders. The  
space between each cylinder and the adjacent rib of the  
35 support is used to stow loops of varying length,

dependent on the surplus length to be stowed.

The loops can allow some slight play or movement of the fibers towards the cable, at least if the first loop is longer than the perimeter of the cylinder. Any such play is very small and may be insufficient, especially when the fibers are more or less loose in the cable structure and traction is applied to the cable.

An object of the present invention is to allow great freedom of movement of the spliced fibers towards the corresponding cable and in a manner that is independent of the surplus length normally allowed for the splices between the fibers and for which stowage means are also provided.

#### SUMMARY OF THE INVENTION

The present invention consists in an optical fiber cable connection organizer device comprising a substantially parallelepiped-shaped support assembly having lateral accessways at two opposite ends for fibers of said cables, first means for retaining splices jointing fibers of said cables, second means for stowing a surplus length at the ends of the jointed fibers and third means for unrestricted storage of an additional slack in the fibers from each cable, the third means coupling said lateral accessways to said second stowage means in said support assembly and including, for the fibers from one of said cables entering via one of said lateral accessways, at least a first individual magazine for stowing a loose coil situated in an end part of said support assembly opposite the lateral accessway for the fibers of the cable concerned and open substantially facing said lateral accessway.

This device also has at least one of the following additional features:

- the third means for stowing the slack further include at least a second individual magazine associated



with the first magazine for storing another loose coil situated in the other end part of said support assembly adjoining the lateral accessway for the fibers of the cable concerned and open facing the other lateral accessway and said first magazine, each second magazine associated with each first magazine being at a level offset to said first magazine and to said lateral accessways;

5  
- a central cylinder in the support assembly between the two sets of magazines, the central cylinder delimiting on each side a loose coil entry opening and a loose coil exit opening in each individual magazine and limiting the minimal length of each loose coil;

10  
- the support assembly includes two support plates with the two sets of individual magazines and the central cylinder between them, one of the support plates being a bottom plate incorporating the lateral accessways and grooves for guiding the fibers of the cables substantially tangentially to the periphery of the central cylinder from each lateral accessway;

15  
- the bottom plate has a recess on a top face in which are housed and accommodated two sets of magazines and from which the central cylinder projects.

20  
The invention further consists in a submarine optical cable joint box utilizing the above device and further comprising a container tube mounted on said device and closed by two covers at the ends to which said cables are anchored and support members fixed to an innermost front face of the covers for seating and fixing the device and guiding the fibers of the cables into the lateral accessways of the device.

25  
30  
35  
The features and advantages of the invention will emerge from the following description of one embodiment given by way of example and with reference to the accompanying drawings.

### BRIEF DESCRIPTION OF THE DRAWINGS

Figure 1 is a partially cut away sectioned view of a submarine cable joint box equipped with a connection organizer device of the invention.

5 Figure 2 is a top view of a bottom plate of the device in its unequipped state.

Figures 3 and 4 are views of this plate in section on the lines III-III and IV-IV, respectively, in figure 2.

10 Figure 5 is a top view of the bottom plate in its equipped state.

Figure 6 is a view of the equipped plate in section on the line VI-VI in figure 5.

15 Figure 7 is a top view of a top plate of the device.

Figures 8, 9 and 10 are views of the top plate in section on the lines VIII-VIII, IX-IX and X-X, respectively, in figure 7.

### DETAILED DESCRIPTION OF THE PREFERRED EMBODIMENT

20 The joint box shown in figure 1 is for jointing two optical fiber submarine cables 1A and 1B. It includes an optical fiber cable connection organizer device 2 held inside a container tube 3 providing mechanical continuity of the jointed cables. The container tube is closed by  
25 two covers 4A and 4B to which the cables are anchored and between which the device 2 is held. The container tube and the covers are made of metal. They have an exterior protective coating extending a short way along the cables on each side. In this embodiment this protection is  
30 provided by two sheaths 5A and 5B that nest one within the other around the central part of the container tube and associated shrinkable sleeves 6, 6A and 6B providing additional protection, in particular sealing, mounted over the nested sheaths and over their end parts and the  
35 cables. Alternatively, this protection can be molded

over the container tube and over the cables on each side of it.

The edges of the covers 4A and 4B are screwthreaded and the container tube has an interior thread at each end for attaching them. Each cover has a bore in which one of the cables is received and anchored, this bore being adapted to suit the construction of the cable its receives. Referring to figure 1, it can be seen that the cover 4A is in one piece and has at its innermost end inside the container tube a frustoconical bore in which the armor wires 7A of the cable 1A are terminated and immobilized by means of a clamping cone 8A. The cover 4B is in two parts that are abutted together, in which condition they are equivalent to a single part fitted to the cable 1B. The cover 4B has a frustoconical bore in its end part inside the container tube for terminating and immobilizing the armor wires 7B of the cable 1B by means of a clamping cone 8B.

A plurality of cones fitting one inside the other within the bore of the cover are used if the cable has a plurality of layers of armor wires.

The fibers of the corresponding cables pass axially through the cones 8A and 8B and are totally or partially freed from the cable, depending on the structure of its optical part.

Members 9A and 9B fixed to the innermost front face of the covers inside the container tube are generally semi-annular in shape and together define a support between the two covers on which the device 1 is seated and to which it is fixed by screws 10A and 10B. The members 9A and 9B have a groove for guiding the fibers into the device 2. They can also anchor the reinforcing members associated with the fibers in the optical part of the cable, if necessary, by means of a stud 11B attached to the central part of the member 9B concerned and fixed

by screws on either side of the fiber guide groove between the member 9B and the stud 11B in the device 2.

Two locknuts 12A and 12B are attached and screwed to the faces of the covers 4A and 4B that face out of the container tube. They are screwed in until they abut  
5 against the ends of the container tube.

To joint the cables 1A and 1B the locknuts 12A and 12B are threaded over the respective cables and the container tube 3 is threaded over one cable. The cables  
10 are stripped and their armor wires are anchored in the covers, with an appropriate length of the fibers passing through the covers.

The fibers are jointed and the surplus lengths are coiled into the device 2 fixed between the covers. The  
15 container tube 3 is then moved beyond the first cover by screwing it past the cover and is then screwed simultaneously onto both covers. The locknuts 12A and 12B are moved up against the covers and screwed to them. The protective sheaths 5A and 5B followed by the sleeves  
20 6, 6A and 6B are then fitted, the latter having been placed on the cables ready for this beforehand.

Still referring to figure 1, in which the device 2 is shown partially cut away, it can be seen that the device 2 includes a bottom plate 20 for receiving the  
25 fibers and stowing slack in the fibers from both cables in magazines 30 and a top plate 40 for stowing the splices and the surplus lengths of the jointed fibers. The magazines 30 are between the plates 20 and 40. They are fixed by screws 13 to the bottom plate 20 and covered  
30 by the top plate. Alternatively they can be fixed to the bottom of the top plate. The top plate 40 is fixed by screws 14 to the bottom plate 20.

The connection organizer device 2 is explained firstly with reference to figures 2 through 4 which show  
35 the bottom plate 20 in its unequipped state and figures 5

and 6 which show the bottom plate equipped with the magazines 30.

5 The bottom plate 20 is rectangular in shape and has a wide rectangular recess 21 in its top face. This recess is delimited by a peripheral rim 22 and a central cylinder 23 projects from the bottom of the recess. This cylinder is slightly higher than the peripheral rim 22 and its diameter is less than the width of the plate. The plate 20 is preferably made from aluminum or aluminum alloy.

10 Two lateral accessways 24A and 24B for the sets of fibers of the two cables are provided through the middle parts of the shorter sides of the peripheral rim 22. They are slightly deeper than the recess 21. Two grooves 25A and 25B are provided in the bottom of the recess to guide the two sets of fibers. They are arcuate in shape and open through a large radius curve into the respective lateral accessways 24A and 24B. They join together and pass tangentially around the cylinder 23, along one of the longer sides of the rim 22. In an alternative arrangement the two guide grooves do not join together but extend around the cylinder along opposite longer sides of the rim 22. Sets of lugs 26A and 26B are provided along the longitudinal opening of the grooves for retaining the set of fibers in each of them. A corresponding opening 27A and 27B is provided through the thickness of the bottom of each groove, under each of these lugs, to facilitate the manufacture of the plate 20.

30 Two pairs of fixing lugs 28A and 28B are provided at the ends of the plate 20. The lugs 28A at one end of the plate are thin and are level with the bottom of the grooves 25A. They have an oblong hole 29A in them with its longer axis parallel to the longitudinal axis of the plate. The lugs 28B are thicker and have a circular hole

35

29B in them, the opening at the top end of which is of larger diameter in order to accommodate the head of a screw.

Referring also to figure 1, in which the members 9A and 9B fixed to the covers of the container tube of the joint box define the support on which the device 2 is seated, it will be understood that the holes 29B receiving the screws 10B do not allow any play of the plate 20 on the members 9B whereas the holes 29A receiving the screws 10A allow slight play of the plate on the member 9A, along the greater axis of the holes 29A.

The plate 20 also has an axial groove 24 joining the lateral accessways directly and intersecting the central cylinder 23. It also has holes 22' at the ends of the shorter sides of the rim 22 and holes 21' at the four corners of the bottom of the recess 21, the former for fixing the top plate and the latter for fixing the magazines to the bottom plate.

The axial groove 24 is for the central strength member, if any, associated with the set of fibers from the optical part of either cable. A central strength member of this kind is terminated and anchored in the central cylinder 23 by means of attached ancillary members that are not shown. The magazines 30 for storing the slack in the set of fibers from each cable are assembled into two identical sets of magazines. Each set of magazines is attached to and housed in the recess 21, between one of the lateral accessways 24A, 24B and the central cylinder 23. It is mounted on the bottom of the recess and against the corresponding peripheral rim and is fixed in place by means of two screws 13 (figures 1 and 6) received in the holes 21' in the plate 20 and in screwthreaded holes 31 in the set of magazines.

The magazines of each set are defined by parallel

plates 32 and 33 with a narrow gap between them attached to a lateral holding member 34. The holding member 34 is generally U-shaped, lying flat in the recess in the plate 20, the width of the branches and the base corresponding to the depth of the recess 21. The inside faces of the branches and the base of the member 34 define a semi-elliptical surface in which the plates 32 and 33 are retained. The outside faces of the branches and the base are flat and pressed against the rim 22 of the plate 20.

The plate 32 is the backing plate of the set of magazines. It is solid and semi-elliptical in shape. The plates 33 each have an axial recess 35, also U-shaped with rounded back and ends, conferring on them an elliptical ring shape. The inside surface of the branches at the base of the holding member 34 incorporates grooves 36 which are superposed and continuous from the end of one of the branches to that of the other branch of this member. These grooves locate the plates 32 and 33 which are fixed, for example glued, to each of them.

The magazines 30 are open on the side facing the cylinder 23. They have an entry opening 37 at the end above the middle part where the guide grooves 25A and 25B join, between the cylinder 23 and the corresponding longer side of the rim. They have an exit opening 38 at the end opposite the cylinder 23.

The individual magazines of each set are defined between two of the plates 32 and 33. They are alternately assigned to stowing considerable slack left in the set of fibers from each of the two cables in the form of a loose coil of variable length in each magazine. This is represented in figure 6 by the letters A and B assigned to the magazines, corresponding to the lateral accessway 24A and 24B and according to their rank in the set of magazines. The magazines in each of the two sets

are assigned according to their rank in each set and starting from the bottom magazine. The odd ranked magazines in the set situated on the plate 20 opposite the lateral accessway concerned and the even ranked  
5 magazines in the other set are all assigned to stowing the slack in the set of fibers entering via that accessway. Thus the magazines 30A are assigned to the fibers entering via the accessway 24A and the magazines 30B to the fibers entering via the accessway 24B. The  
10 first of the magazines 30A to be used to stow the set of fibers from the accessway 24A is the bottom magazine in the set facing that accessway, the second to be used is the second magazine from the other set and the third to be used is the third magazine from the first set. A  
15 comparable scheme applies to the magazines 20B assigned to the set of fibers from the accessway 24B. The number of magazines in each set is chosen to store a maximal length of slack. This number is 3 in the present embodiment, but could be greater than 3.

20 Stowing the slack in the set of fibers from each cable enables the fibers to move towards the cable when the latter is loaded in traction and the set of fibers is loose within the cable structure. Under these  
25 conditions, the loops in the magazines are successively tightened around the central cylinder 23 with the result that the set of fibers is not stressed when the cable is loaded in traction. The diameter of the cylinder 23 is naturally chosen so that the radius of curvature of the fibers around the cylinder is acceptable.

30 The top plate 40 of the device for organizing the connections between two optical fiber cables is described with particular reference to figures 7 through 10. Its attachment to the bottom plate is further explained with reference to figures 1, 5 and 6 in particular.

35 The plate 40 is rectangular in shape and covers the



bottom plate. It has two notches 41A and 41B on opposite sides of a middle portion of one of its two longer edges, through which pass fibers from the top magazines 30A and 30B used. Its top face is recessed and has a peripheral rim 42 interrupted by the notches 41A, 41B. It is fixed to the bottom plate 20 equipped with its two sets of magazines 30 by four screws 14 received in the holes 22' in the bottom plate and in corresponding screwthreaded holes 42' through the top plate, in its rim 42. Location of the plate 40 on the plate 20 is facilitated by a circular imprint 43 provided on its bottom face to receive the end of the central cylinder 23 on the bottom plate.

The plate 40 has projecting ribs 44 in the middle part of its notched top face and two projecting lateral cylinders 45A and 45B on opposite sides of the ribs.

The ribs 44 are parallel to the longer sides of the plate and define between them and the longer sides of the rim 42 grooves 46 for retaining splices between the fibers. Bosses 47 at the ends of the ribs and in corresponding relationship thereto on the longer sides of the rim project into the grooves to wedge the splices. The grooves are discontinuous, being divided into two sets defining a central housing between the two sets of grooves. This housing receives a removable plate 50 for holding the splices against the bottom of the grooves. The plate 50 advantageously carries a foam pad 51 on the side pressed against the splices. It locks into two facing slots 52 in the longer sides of the rim 42. There are advantageously two such slots 52 on each rim, to define two levels at which the plate 50 is secured over the splices in the grooves, e.g. for a single splice or two superposed splices in each groove.

To make the drawings clearer the fibers and the splices between them are not shown. Suffice to say that

the splices are protected for increased strength.

The two cylinders 45A, 45B are for stowing surplus lengths of the two sets of jointed fibers, these surplus lengths being totally independent of the slack provided in each set of fibers from the cables, which are already  
5 stowed in the magazines. They correspond to a peripheral space 49A or 49B around each of them delimited by the ribs and by the adjoining part of the rim 42, the shorter side of which is semi-circular on the inside. Each space  
10 communicates through one of the notches 42A and 42B with the equipped bottom plate.

Foam blocks 55 shown in dashed outline are wedged elastically between the rim 42 and each lateral cylinder 45A or 45B to hold the coils of fibers stowed in the  
15 space around each of these cylinders.

Note that the longer sides of the rim 42 are beveled on the outside so that they do not impede sliding of the container tube over the organizer device 2 (figure 1).

In the submarine optical cable joint box shown in figure 1 the container tube protects the connection organizer device 2. For terrestrial link optical cables the organizer device 2 is protected by a cover covering the top plate. As an alternative to this the top plate  
25 can form a cover which preferably has its bottom face provided with the splice retaining grooves and the lateral cylinders for stowing excess lengths of the jointed fibers and assembled to the bottom plate, without the notches that communicate with the equipped bottom  
30 plate.

This optical fiber cable connection organizer device is suitable for cables with various structures which can cause movement of the sets of fibers when they are mechanically loaded in traction. It enables a  
35 considerable slack in the set of fibers from the cables

to be stowed, independently of a surplus length provided for splicing the fibers and stored separately from this slack. It prevents any tangling of the loose coils providing the slack with each other and with the coils stowing the surplus lengths provided for the splices. The splices between the fibers are advantageously provided with exterior reinforcing protection and are thereby held in the device.

**CLAIMS**

1. Optical fiber cable connection organizer device comprising a substantially parallelepiped-shaped support assembly having lateral accessways at two opposite ends  
5 for fibers of said cables, first means for retaining splices jointing fibers of said cables, second means for stowing a surplus length at the ends of the jointed fibers, characterized in that it includes third means  
10 (30) for unrestricted stowing of an additional slack in fibers from each cable, coupling said lateral accessways (24A, 24B) to said second stowage means (45A, 45B) in said support assembly (20, 40) and including, for the fibers from one of said cables entering via one of said lateral accessways (24A, 24B), at least a first  
15 individual magazine (30A, 30B) for stowing a loose coil situated in an end part of said support assembly opposite said lateral accessway for said fibers of the cable concerned and open substantially facing said lateral accessway.

20 2. Device according to claim 1 characterized in that said third means for stowing the slack further include at least a second individual magazine associated with said first magazine for storing another loose coil situated in the other end part of said support assembly  
25 adjoining said lateral accessway for the fibers of the cable concerned and open facing the other lateral accessway and said first magazine, each second magazine associated with each first magazine being at a level offset to said first magazine and to said lateral  
30 accessways.

3. Device according to claim 1 or claim 2 characterized in that said individual magazines (30A, 30B) define two sets of superposed individual magazines in respective end parts of said support  
35 assembly adjoining said lateral accessways.

4. Device according to claim 3 characterized in that it further comprises a central cylinder (23) in said support assembly between said two sets of magazines (30), delimiting on each side a loose coil entry opening (37) and a loose coil exit opening (38) in each individual magazine and limiting the minimal length of each loose coil.

5. Device according to claim 4 characterized in that said support assembly includes two support plates (20, 30) with said two sets of individual magazines (30) and said central cylinder (23) between them, one of the support plates being a bottom plate (20) incorporating said lateral accessways (24A, 24B) and grooves (25A, 25B) for guiding the fibers of said cables substantially tangentially to the periphery of said central cylinder (23) from each lateral accessway.

6. Device according to claim 5 characterized in that said bottom plate (20) has a recess on a top face in which are housed and accommodated two sets of magazines (30) and from which said central cylinder projects.

7. Device according to claim 6 characterized in that the other support plate (40) has a recess on one face in which said first splice retaining means are defined by a series of parallel ribs (44) projecting from a central part of that side to retain said splices between them and by said second means for stowing a surplus length of the jointed fibers by means of two lateral cylinders (45A, 45B) projecting from the same face on each side of said series of ribs (44).

8. Device according to claim 7 characterized in that said ribs (44) are discontinuous and organized as two facing sets separated from each other by a housing (48), and in that it includes a removable plate (50) in said housing for retaining the splices in place between the ribs.

9. Submarine optical cable joint box utilizing the device as claimed in any one of claims 1 through 8, characterized in that it further comprises a container tube (3) mounted on said device (2) and closed by two covers (4A, 4B) at the ends to which said cables are anchored and support members (9A, 9B) fixed to an innermost front face of said covers for seating and fixing said device (2) and guiding the fibers of the cables into said lateral accessways (24A, 24B) of said device.



Application No: GB 9609250.7  
Claims searched: 1-9

Examiner: Chris Ross  
Date of search: 24 June 1996

## Patents Act 1977 Search Report under Section 17

### Databases searched:

UK Patent Office collections, including GB, EP, WO & US patent specifications, in:

UK CI (Ed.O): G2J(JGEA)

Int CI (Ed.6): G02B

Other:

### Documents considered to be relevant:

Category	Identity of document and relevant passage	Relevant to claims
X	GB 2229545 A (STC) Figs 1,6,7	1 at least
"	GB 2165661 A (TC) Fig 4	"
"	EP 0595395 A1 (PIRELLI) Fig 1	"
"	US 5341451 A (LATTE) Figs 1,2,7	"
"	US 5119459 A (PORTA) Figs 3,4,spools 48,50	"
"	US 4502754 A (NE) Figs 4,5	"
"	US 4428645 A (GKT) Fig 5	"

X	Document indicating lack of novelty or inventive step	A	Document indicating technological background and/or state of the art.
Y	Document indicating lack of inventive step if combined with one or more other documents of same category.	P	Document published on or after the declared priority date but before the filing date of this invention.
&	Member of the same patent family	E	Patent document published on or after, but with priority date earlier than, the filing date of this application.