

[54] AIRCRAFT

[76] Inventors: Carl Parise, 1990 Pheasant La., Reno, Nev. 89509; Lawrence K. Heuberger, 10605 Whitehawk La., Reno, Nev. 89506

[**] Term: 14 Years

[21] Appl. No.: 922,143

[22] Filed: Jul. 5, 1978

[51] Int. Cl. D12-07

[52] U.S. Cl. D12/332; D12/338; D12/339

[58] Field of Search D12/78; 244/45 R, 13, 244/91

[56] References Cited

U.S. PATENT DOCUMENTS

- D. 189,325 11/1960 Thieblot D12/78
- D. 193,255 7/1962 Gilmore et al. D12/71

Primary Examiner—Sam Rosen
Attorney, Agent, or Firm—Sughrue, Rothwell, Mion, Zinn and Macpeak

[57] CLAIM

The ornamental design for an aircraft, as shown.

DESCRIPTION

FIG. 1 is a top plan view of an aircraft showing my new design;
 FIG. 2 is a right side elevational view thereof, the left side being a near mirror image thereof;
 FIG. 3 is a front elevational view thereof;
 FIG. 4 is a rear elevational view thereof; and
 FIG. 5 is a bottom plan view thereof.

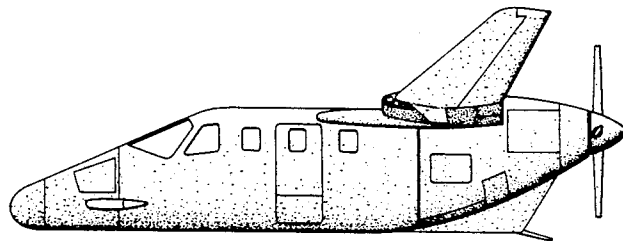
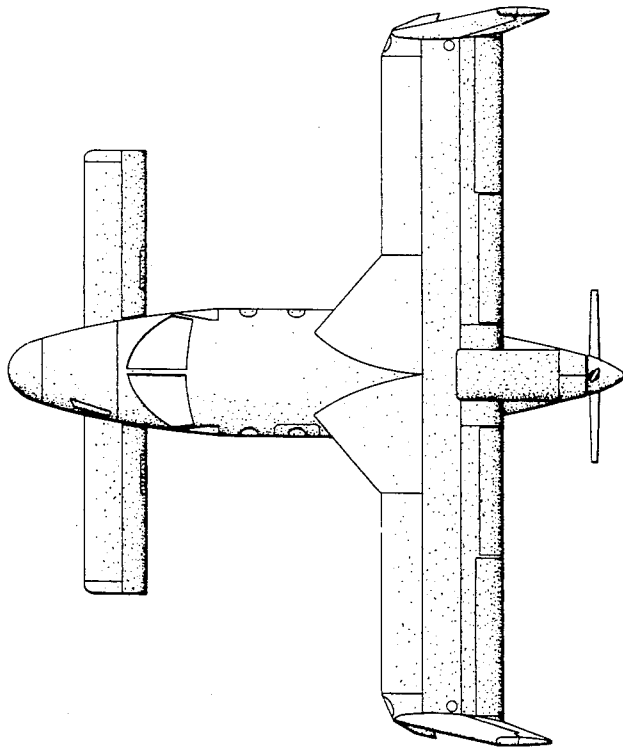

FIG 1

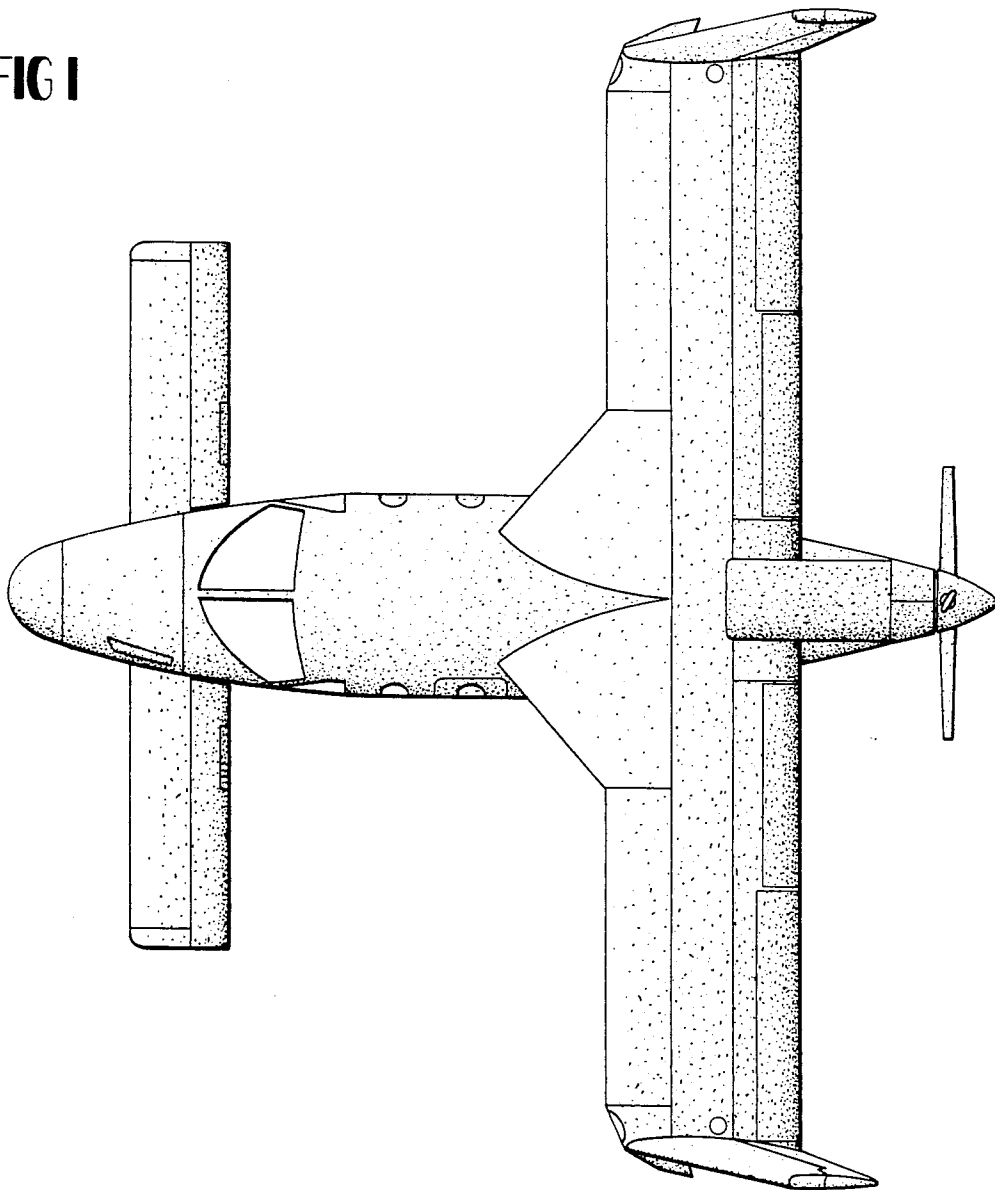
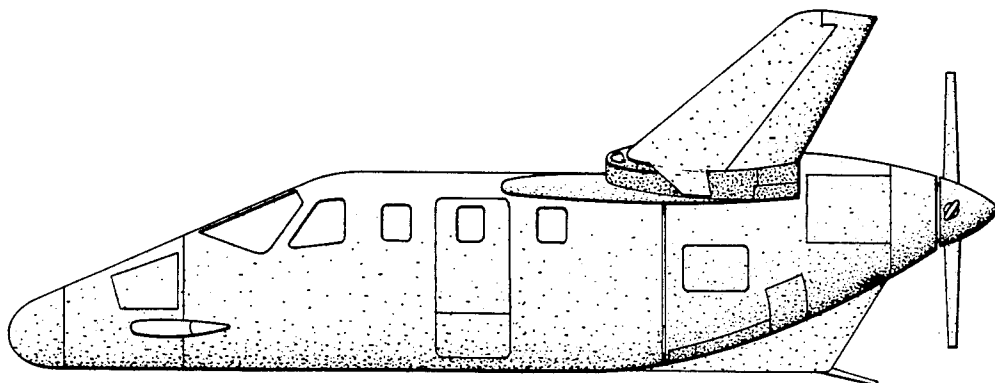

FIG 2



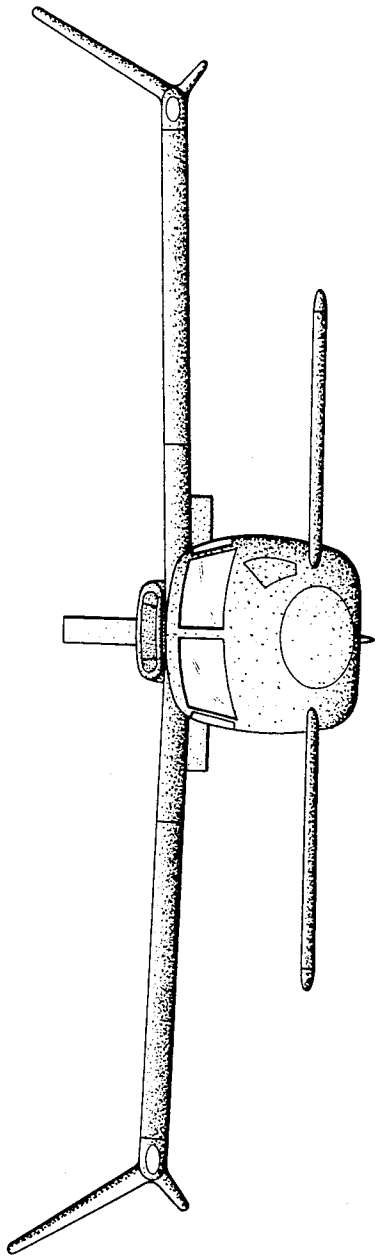

FIG 3

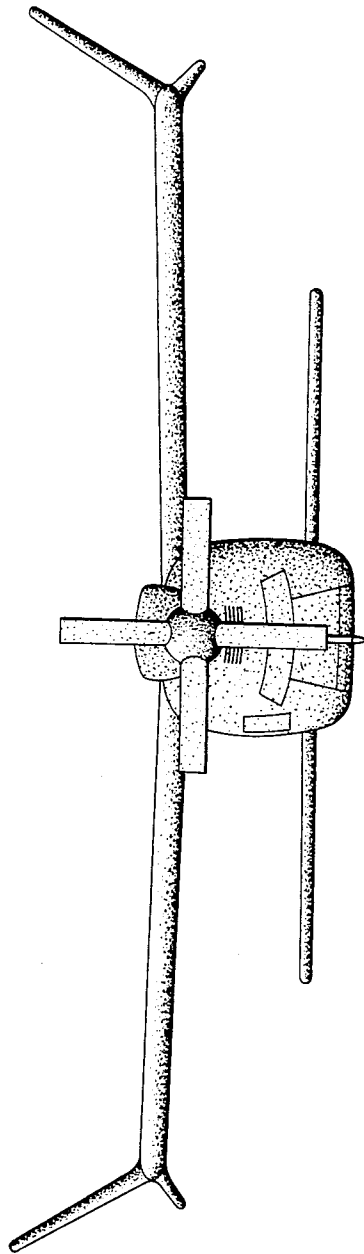

FIG 4

FIG 5

