

Aug. 8, 1961

M. A. SNABLE

2,994,897

SQUEEZE CONTAINER WITH APPLICATOR

Filed Aug. 18, 1959

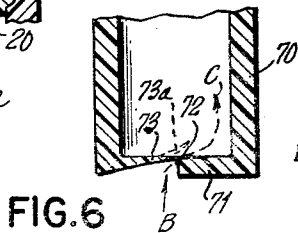
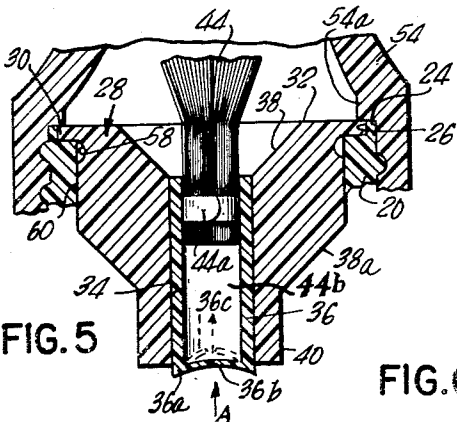
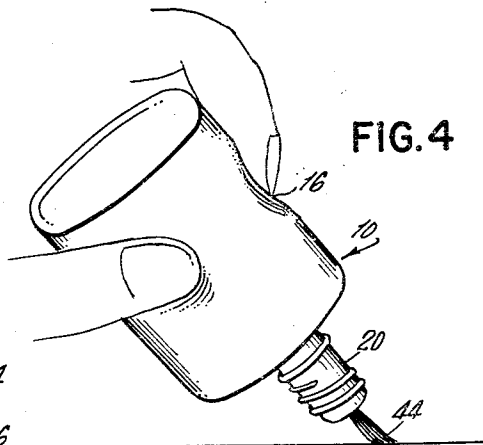
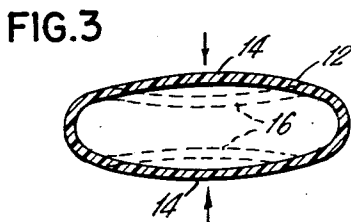
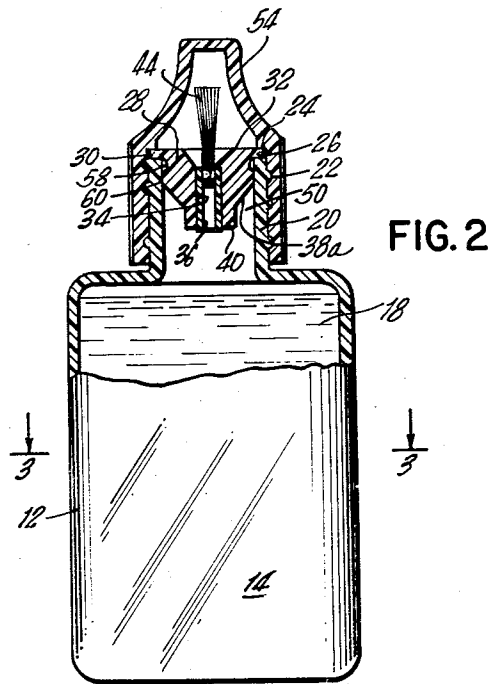
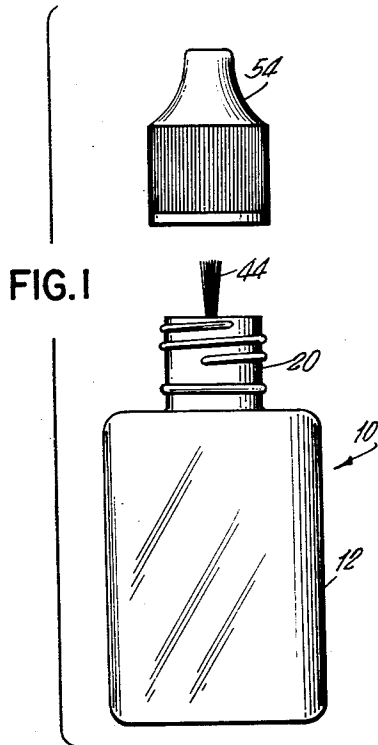

INVENTOR.  
MYRON A. SNABLE  
BY *Leon M. Stewart*  
AGT.

1

2,994,897

**SQUEEZE CONTAINER WITH APPLICATOR**

Myron A. Snable, 25 Parkview Ave., Broad Acres,

P.O. Box 167, Basking Ridge, N.J.

Filed Aug. 18, 1959, Ser. No. 834,448

1 Claim. (Cl. 15-543)

This invention relates to dispensers or containers equipped with an applicator and more particularly to a novel squeeze bottle provided with a brush or like implement for applying a liquid or semi-liquid substance to a surface.

The primary object of the present invention resides in the provision of means for controlling the flow conditions of said substance to and from the applicator, whereby said substance such as nail polish, lacquer, paint, furniture varnishes, liquefied make-up and cosmetics, as well as various pharmaceutical preparations may be applied as a predetermined thin film or like layer and at a predetermined rate to a surface, the rate of flow being capable of being increased or decreased at will by the operator or user.

Another important object of the invention is to provide means envisioning the combination of a squeeze container having attached thereto an applicator with a built-in valve or like control organ, which is responsive to the squeeze pressure exerted on said container, so that from the latter no substance will be fed to the applicator in any position of the container, if desired.

Heretofore various applicators for liquid and like substances have been employed utilizing brush means for dispensing the liquid. However, because of the arrangement of the brush with respect to the fluid in the container, the bristles of the brush were subject to two seemingly unreconcilable failings; the bristles either received too little fluid because of the manner of mounting of the bristles or the bristles were likely to come loose from their mountings when arranged so as to receive enough fluid.

The present invention obviates both of the above and other known shortcomings by an unexpected result achieved by positioning and retaining a plastic feed sleeve in a polyethylene plug or insert of special design with the bristles being securely held in the said sleeve yet only extending partially into the sleeve, the insert being mounted in the neck of a squeezable container and when the latter is in closed condition in an air-tight manner.

A further object of the present invention resides in the provision of means conducive to a very efficacious applicator container that is provided with a tapered surface to facilitate insertion and anchorage of the tuft of bristles forming the brush, whereby also the outer surface of the container may be easily cleaned of fluid, and any excess liquid may readily flow back toward the base of the brush and thence through capillary action into the interior of the container.

Still another object of the invention resides in the provision of means affording inexpensive production of a squeezable container which is easy to carry and hold and which can be provided with a convenient cap for safeguarding a lady's purse, cosmetic bag, suitcase or the like from any leakage of fluid.

Yet another object of this invention resides in the provision of means facilitating the application of nail polish to the nails of a lady's finger without requiring intermittent dipping of a brush into nail polish fluid.

Still a further object of this invention is to provide means instrumental in creating a very efficient applicator with container, which is simple in construction, capable of being mass produced, employing readily available

2

materials, and which is highly attractive and ornamental in appearance.

These, together with various ancillary objects and features of the invention which will become apparent as the following description proceeds, are attained by the present invention, a preferred embodiment of which is illustrated in the accompanying drawing by way of example only, wherein:

FIG. 1 is a side elevational view of a container embodying the invention, the container being shown with the cap thereof removed;

FIG. 2 is an enlarged vertical sectional view of the container with the cap applied to the container;

FIG. 3 is a transverse sectional view as taken along lines 3-3 in FIG. 2;

FIG. 4 is a perspective view showing the container or bottle in position of use;

FIG. 5 is an enlarged fragmentary sectional view similar to that of the upper part of the container with applicator seen in FIG. 2;

FIG. 6 is a vertical sectional view through the lower part of the sleeve in modified form, to which reference is made in the specification.

With continuing reference to the accompanying drawing wherein like reference numerals designate similar parts throughout the several views, reference numeral 10 generally designates the container with applicator which includes squeezable container 12 of polyethylene or other flexible resilient synthetic plastic material which may be transparent, translucent, or opaque and colored as desired.

As can best be seen in FIG. 3, the container 12 may be substantially of cylindrical form or as shown of elliptical shape with bulging sides as at 14, which may be depressed to the position at 16 indicated in phantom lines (see also FIG. 4). The container is adapted to be filled with any suitable liquid or like fluid as at 18, such as nail polish or lacquer, paint, liquid cosmetic and therapeutic preparations, as well as other types of coating material.

The container 12 is provided with a neck 20 externally threaded as at 22 and provided with an upstanding circular rim 24 having a groove 26 along the inner peripheral edge thereof. Received in the neck 20 is a plug or insert 28. The insert 28 is provided with a peripheral flange 30 adapted to fit in the groove 26 and has its surface 32 lying substantially flush with upstanding rim 24. The insert 28 is preferably made of polyethylene and has a bore 34 therethrough in which there is force fitted a sleeve 36 made of plastic composition.

The insert is provided with an inner tapered central portion 38 and with an outer tapered portion 38a terminating in a cylindrical portion 40 which is spaced from the neck 20. The cylindrical portion 40 may be shaped for the purpose of preventing a build up of liquid on the sleeve 36. The sleeve 36 being formed of synthetic plastic composition which is of great strength, can be force-fitted into the polyethylene plug or insert substantially without any distortion of the sleeve though with considerable stress thereon sufficient to distort the insert adjacent the sleeve to fixedly hold the sleeve in place. This assures that the bristles 44 received in the sleeve 36 will not be compressed undesirably so as to prevent proper passage of flow therebetween as would be the case if a less tough and strong material than nylon were to be used for the sleeve 36.

Thus, the bristles 44 can be assembled and easily mounted, e.g., by means of a stainless steel band or wire 44a through funnel-shaped portion 38 in recess 36 so as to extend less than half way into said sleeve, as can best be seen in FIG. 2. This permits fluid to be fed in

a direct stream onto the ends of the bristles assuring proper desired feeding of fluid.

The spacing of the cylindrical portion 40 and tapered portion 38a of the insert from the neck of the bottle yields a cylindrical space of trapezoidal cross section as at 50 which forms a reservoir of fluid and the assurance that should the squeeze bottle or container be accidentally squeezed when the cap is removed, fluid will be forced into the space 50 prior to pressure being applied to the bristles, thus assuring somewhat undersired accidental pressure application.

As can be seen in FIGS. 5 and 6, sleeve 36 or sleeve 70 is provided with slotted bottom for further regulating the fluid flow.

According to FIG. 5 bottom 36a of sleeve 36 is inwardly curved and is provided with a central slit 36b which opens so that bottom 36a is displaced to position 36c in which slit 36b is sufficiently opened to permit controlled quantitative passage of liquid 18 therethrough depending on the squeeze pressure.

A cap 54 is provided which has an upper contour designed to encompass the brush 44 while of pleasing contour. The cap is preferably molded of a relatively rigid material such as cellulose acetate, polyvinyl chloride or like synthetic or other material and serves to protect the bristles of the brush 44 and to press at 54a against flange 30 and rim 24.

In use, fluid will flow into the sleeve 36 and onto the bristles 44 whence it may be applied to the surface to be treated. In the event it is desired to paint or coat a surface from beneath, pressure may be applied on the fluid by squeezing the bottle or container 12 forcing the fluid into the sleeve 36 and thence to the bristles 44. Further, should a heavier coating be desired, greater pressure can be applied on the container sides 14 thus feeding fluid under pressure via valve 36a-36b or 72, 73 via slot 73a of bottom 71 in the directions A or B and C (FIG. 6) to the bristles 44.

It is noted that the insert is undercut at 58 and has a portion 60 in fluid-tight contact with the inner surface of the neck 20 capable of being force-fitted in place because of the undercut 58.

Thus it can be seen that there has been designed a container with applicator comprising a squeezable container 12 having a neck 20 threaded as at 22 for receiving a cap 54. An insert 28 is seated in the neck and has a bore 34 therethrough for receiving a sleeve 36 having an inwardly curved bottom with slit and which is provided with bristles 44 extending outwardly of the sleeve and neck and forming a brush or like implement.

Further, the invention employs the concept of using a relatively strong sleeve of synthetic plastic material or composition within a polyethylene insert.

As above stated, the tuft of bristles 44 is preferably held together by a band or wire made from stainless steel material 44a and then forced into the interior of sleeve 36, as is more clearly depicted in FIG. 5.

Sleeve 36 is provided with a slightly inwardly curved bottom or end 36a having a fine slit 36b which upon applying pressure against the exterior of container 12 (as demonstrated in FIG. 4) will force liquid from the interior of container 12 through said slit 36b, whereby the end wall 36a is displaced to assume a position 36c (shown in dotted lines). The pressure from the interior of the bottle or container 12 is indicated by arrow A.

In order to tightly close cap 54 on the container neck

20, cap 54 is provided with an annular shaped projection 54a adapted to firmly hold down insert 28 within the opening 26 of the neck 20 whereby rim 24 as well as flange-shaped ends 30, 32 are compressed when cap 54 is screwed home onto neck 20.

FIG. 6 shows an enlarged modification of sleeve 70 (similar to sleeve 36) having a flap valve consisting of a bottom wall 71, which is partly cut off and slit as at 72, whereby application of pressure as indicated by arrow B from the interior of the container 12, lifts the relatively thin lip 73 into a position indicated in dotted lines at 73a, to permit passage of liquid or like substance in the direction of arrow C within sleeve 70.

The present invention offers also the possibility of readily replacing insert 28 and/or sleeve member 36 together with brush 44 (instead of the brush a perforated or imperforated cuticle treating applicator may be employed for feeding cuticle treatment substance to the nails).

It is further to be noted that an ante-chamber or reservoir 44b for such substance can be maintained between the end of brush or applicator 44 and bottom 36a (or 71) within sleeve 36 or 70 as the case may be.

Since from the foregoing the construction and advantages of this device with valve-controlled dispenser are readily apparent, further description is believed to be unnecessary. However, numerous modifications and equivalents will readily occur to those skilled in the art and it is therefore not intended to limit the invention to the precise embodiment shown and described, but all suitable modifications and equivalents may readily be resorted to which fall within the scope of the appended claim.

Having thus described the invention, what is claimed as new and desired to be secured by Letters Patent is:

A dispenser comprising, in combination, a squeeze container having a hollow neck and made of polyethylene, an insert plugged into said neck and made of polyethylene, said insert having a central bore terminating in a countersunk recess, a sleeve made of nylon seated with force-fit in said bore and rearwardly of said recess, an applicator seated in said sleeve at one end thereof adjacent said recess and being spaced from the other end of said sleeve, said other end of said sleeve being provided with a flap valve integral with said sleeve and including a lip normally opening into a reservoir defined by a portion of said sleeve located between said applicator and said flap valve, whereby upon compressing said container, substance when received therein, is forced into said reservoir and thence to said applicator, whereas excess substance from the latter may be returned to said reservoir via said countersunk recess of said insert, and a cap closing said container at said neck exteriorly thereof and seated against a flange provided on said insert to seal said insert and said applicator.

#### References Cited in the file of this patent

##### UNITED STATES PATENTS

195,015	Jenkins	Sept. 11, 1877
201,127	Ross	Mar. 12, 1878
2,219,141	Ritz	Oct. 22, 1940
2,253,779	Gutierrez	Aug. 26, 1941
2,279,320	Huston	Apr. 14, 1942
2,659,919	McCabe et al.	Nov. 24, 1953
2,905,956	Fuller et al.	Sept. 29, 1959