



US 20050288089A1

(19) **United States**

(12) **Patent Application Publication**

Cammegh et al.

(10) **Pub. No.: US 2005/0288089 A1**

(43) **Pub. Date: Dec. 29, 2005**

(54) **AUTOMATIC ROULETTE WHEEL**

Publication Classification

(76) Inventors: **Richard William Cammegh, Kent (GB); Frank Reginald Cammegh, Kent (GB)**

(51) **Int. Cl.⁷ A63F 9/24**

(52) **U.S. Cl. 463/17**

Correspondence Address:
ANTHONY R. BARKUME
20 GATEWAY LANE
MANORVILLE, NY 11949 (US)

(57) **ABSTRACT**

An automatic roulette wheel in which at the end of a turn the wheel is accelerated and the ball is ejected from the pocket under centrifugal force and moves to the top of the ball track and the direction of rotation of the wheel reversed. The ball is held against the edge of the ball track by air jets after a predetermined time the ball spirals down the slope into a pocket on the wheel.

(21) Appl. No.: **10/876,818**

(22) Filed: **Jun. 25, 2004**

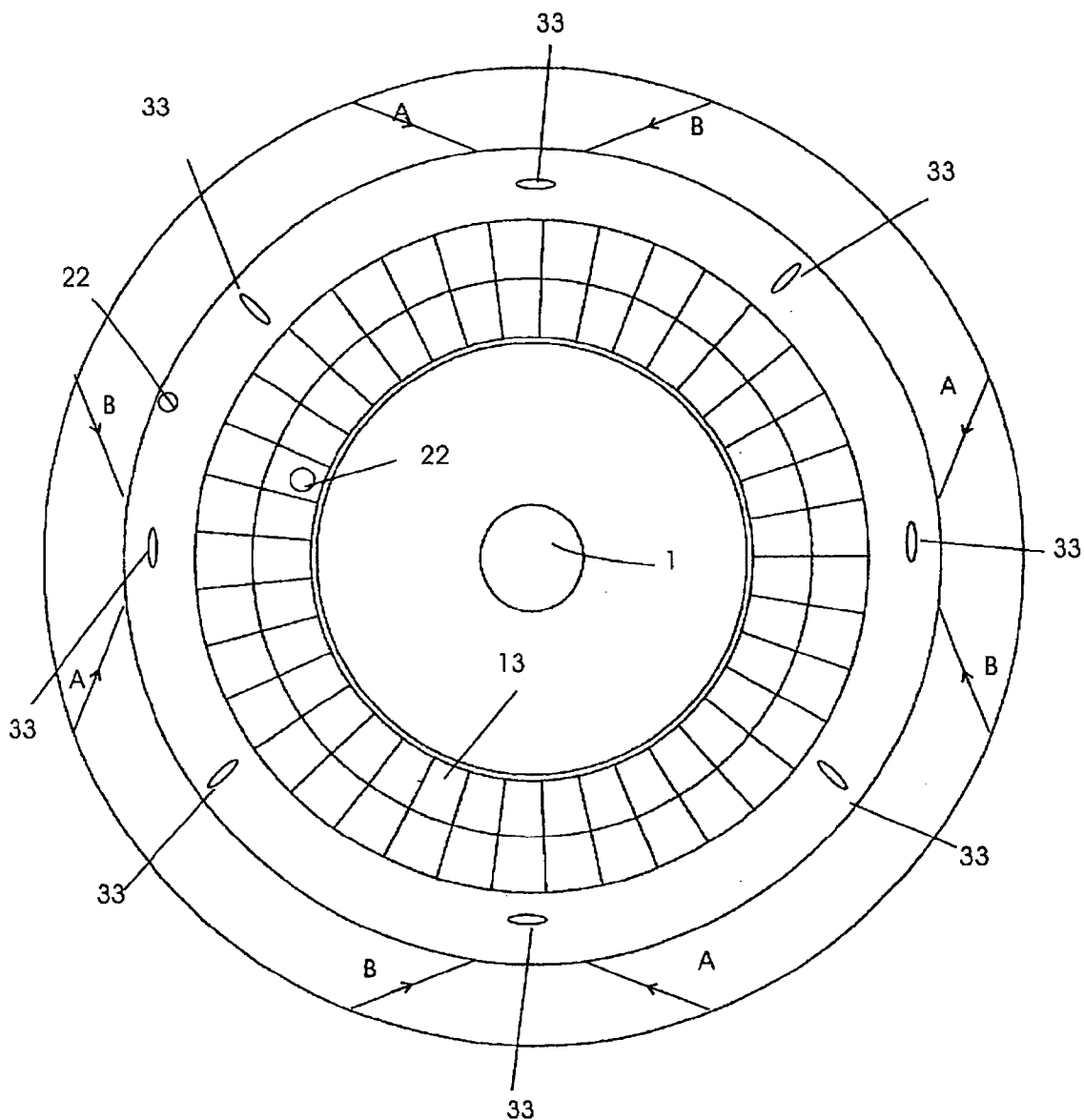

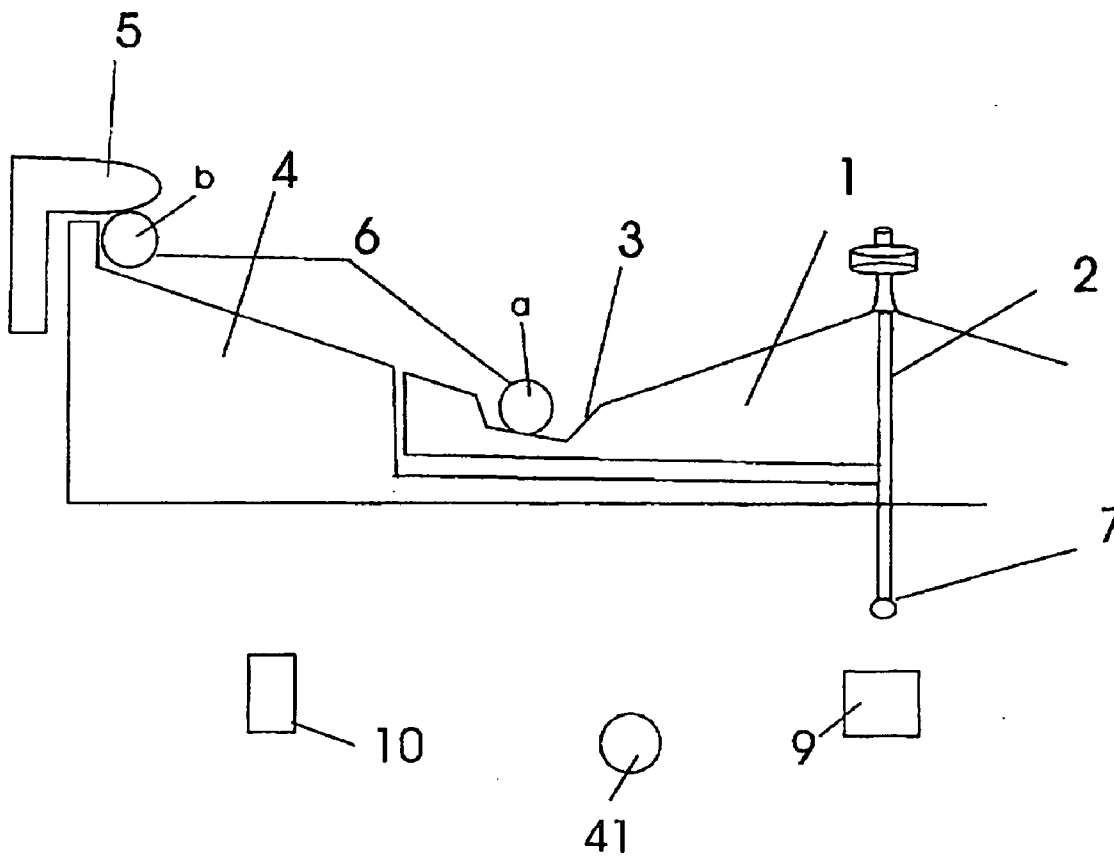

Fig. 1

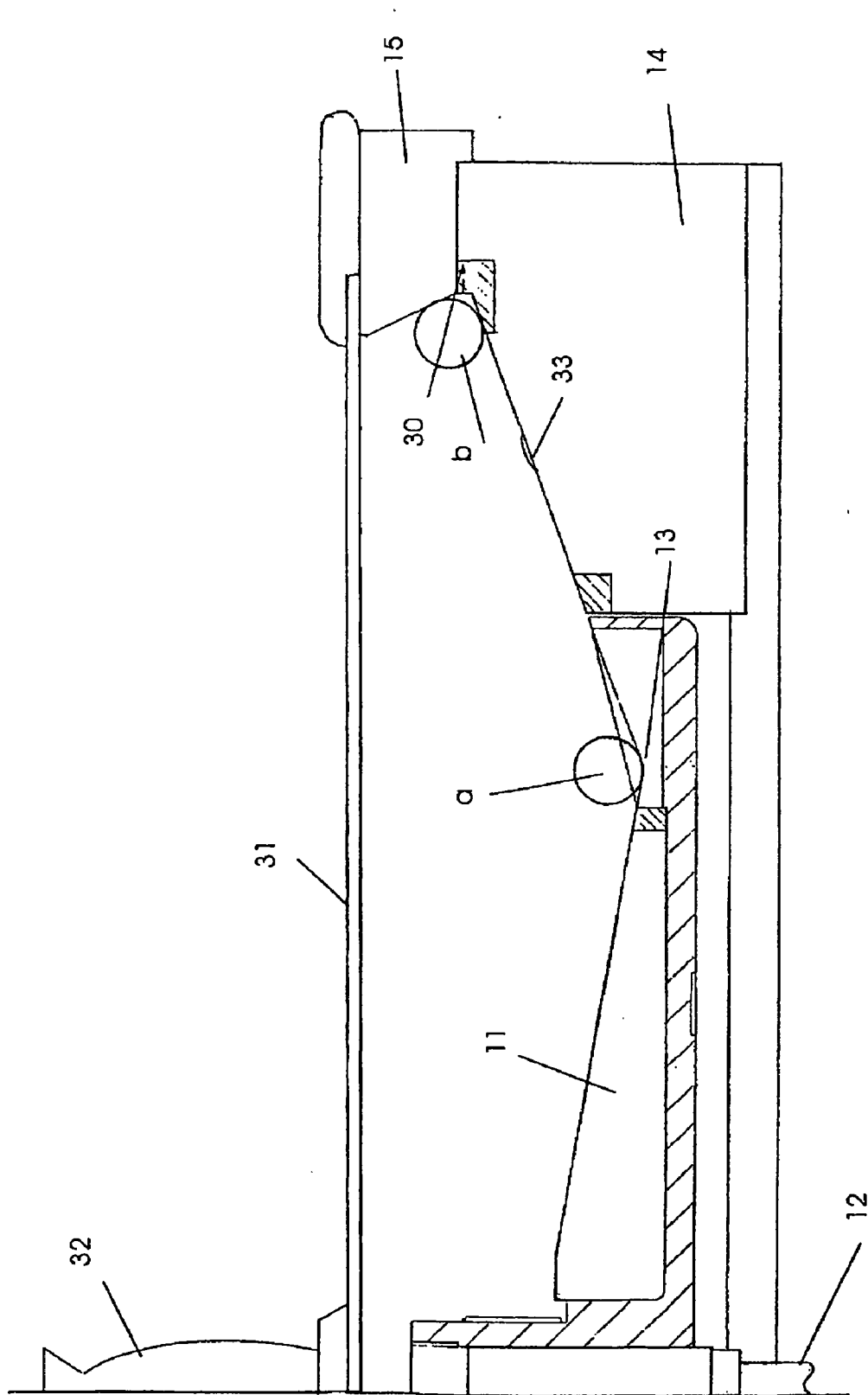

Fig. 2

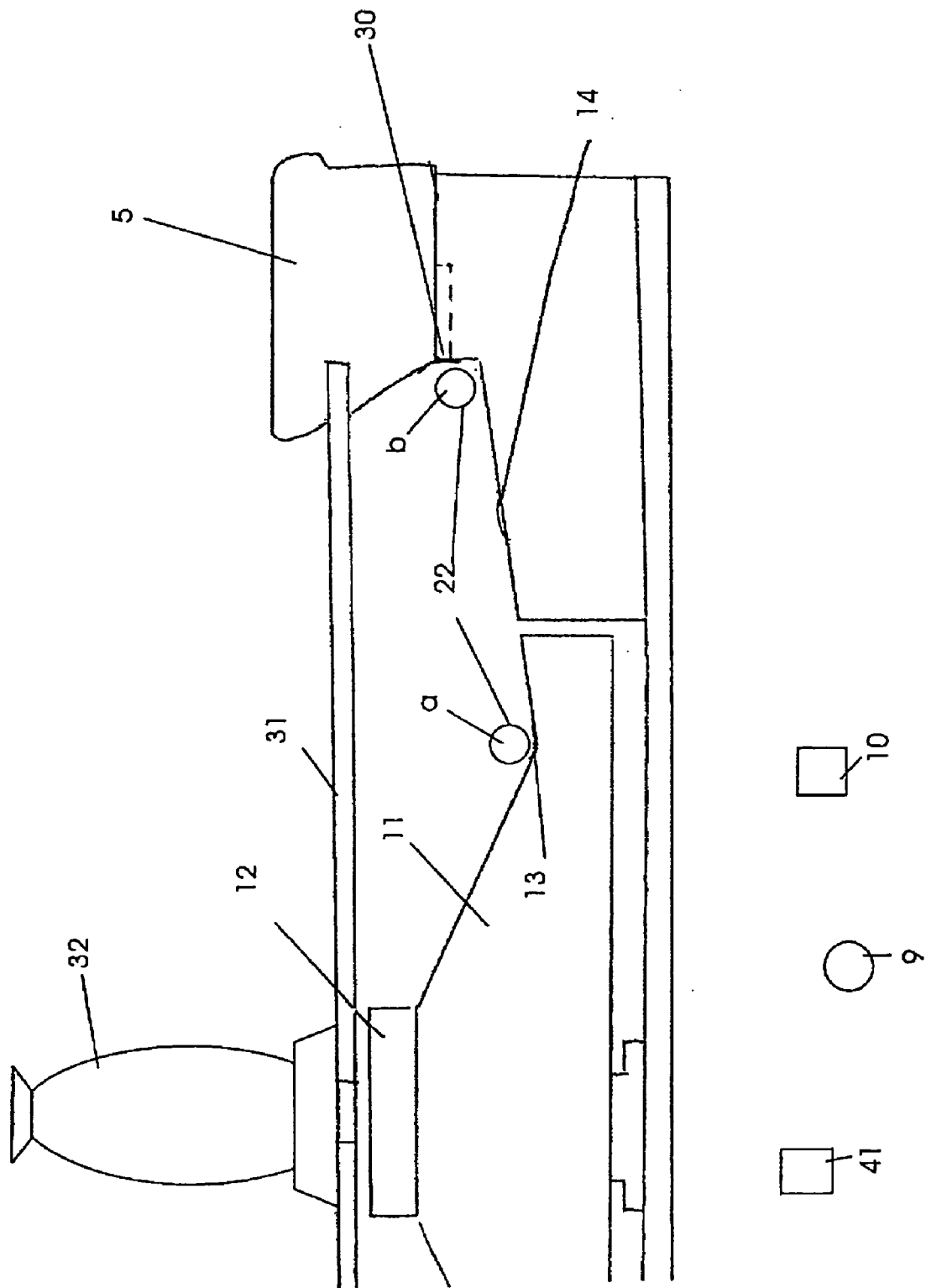

Fig. 3

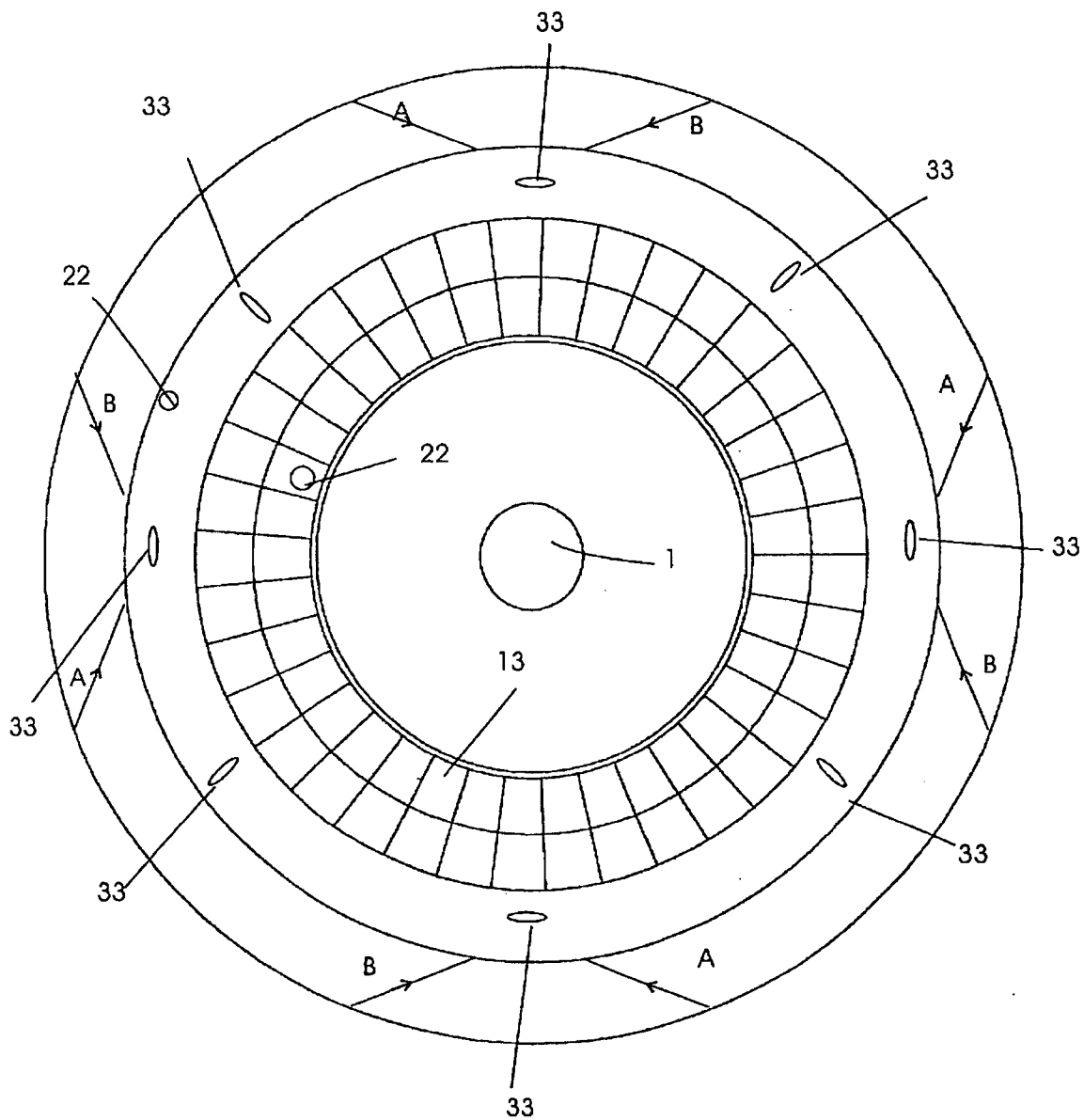

Fig. 4

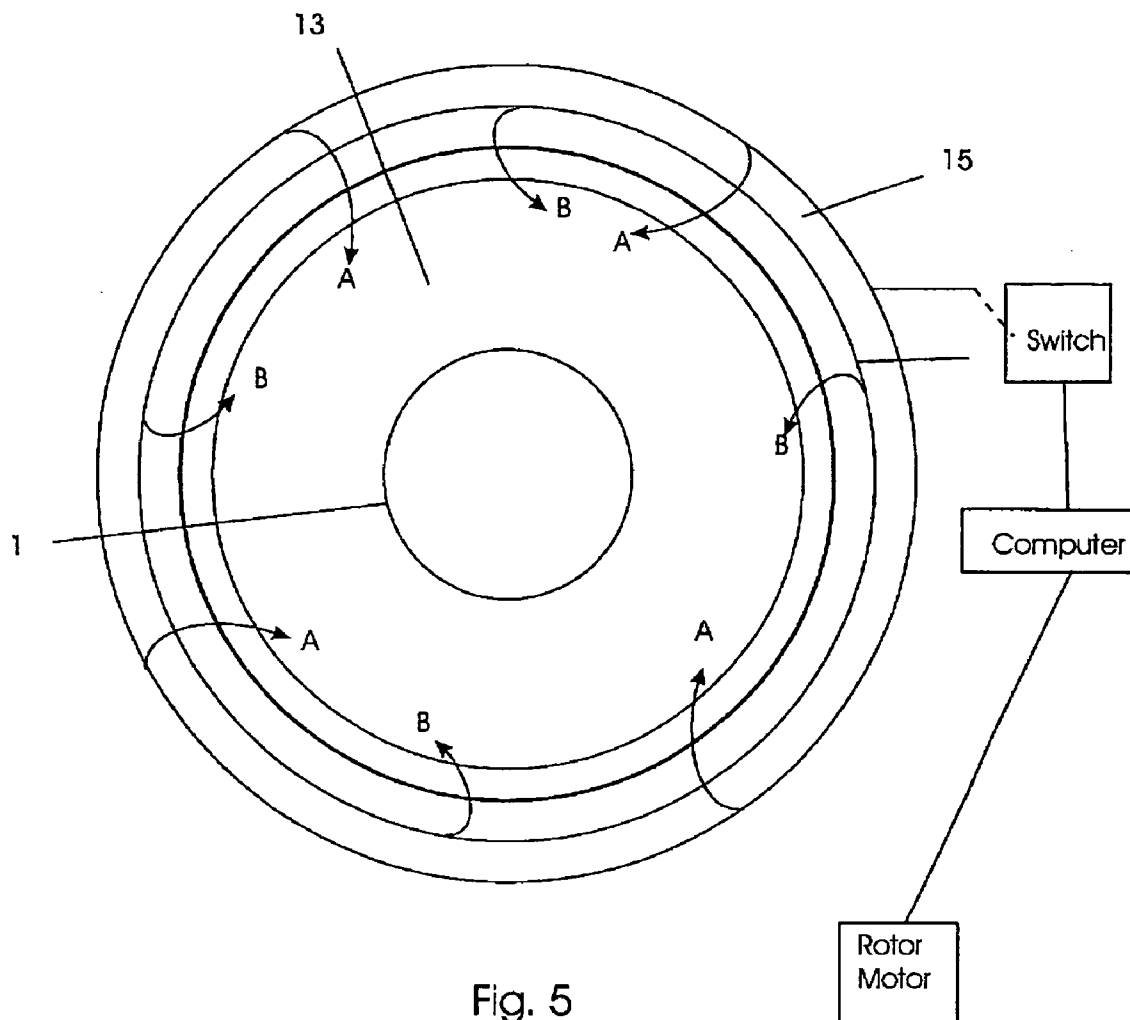

Fig. 5

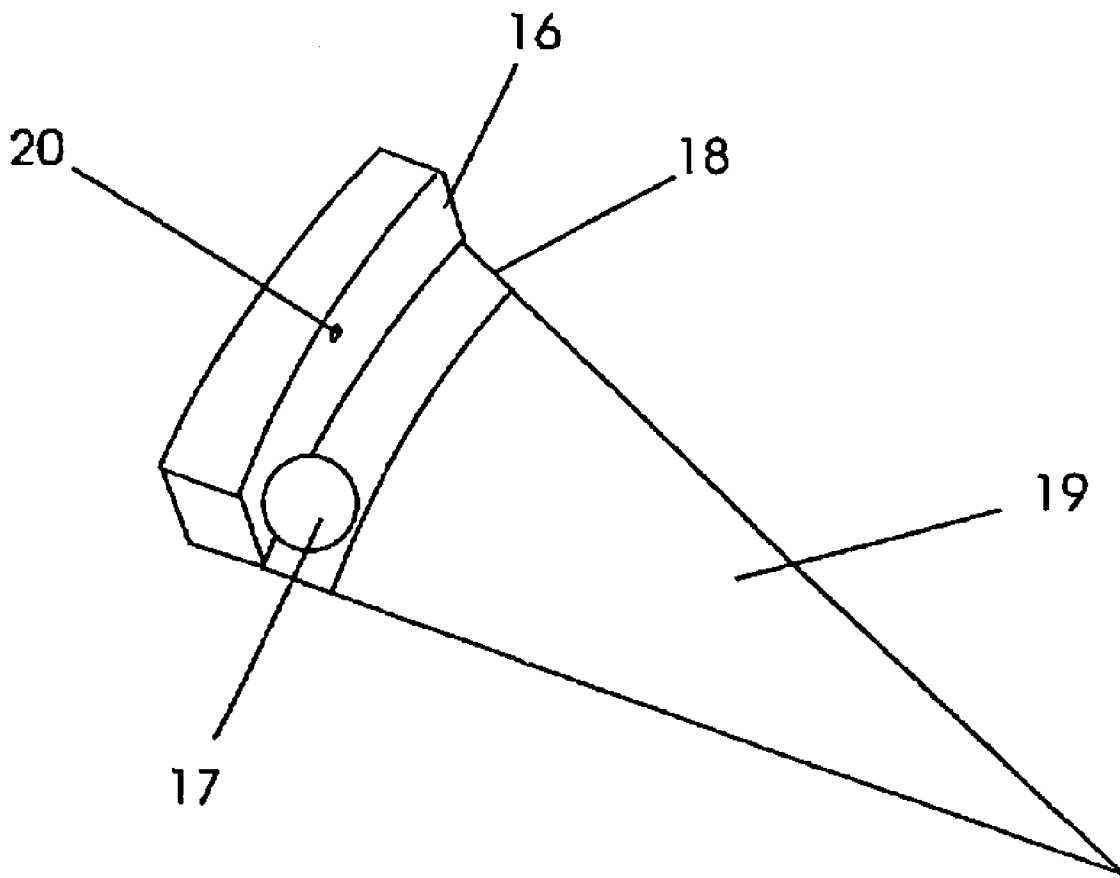

Fig. 6

AUTOMATIC ROULETTE WHEEL

[0001] The present invention relates to gaming wheels, more particularly it relates to roulette wheels in which the ball is automatically put in play.

[0002] Roulette is a well-known casino game which has been played for many years. A typical conventional roulette game includes a table bearing a felt covering upon which indicia forming a betting layout has been silk-screened or otherwise imprinted. A typical roulette wheel includes a number ring bearing a circular array of numbered segments bearing numbers 1 through 36. In addition, the number ring typically includes the numbers 0 and 00 disposed at diametrically opposite locations on the number ring. The numbers 1 through 36 are not disposed in numerical order, but are typically disposed in a predetermined arrangement, such that roulette wheels located in different casinos will have the same standard predetermined number ring arrangement. The numbers disposed in a circular array in the number ring region of the wheel bear the alternating colours of red and black, with the exception of the 0 and 00 numbers, which are typically coloured green. A ring of pockets corresponding in number to the plurality of numbers of the circular number ring lies adjacent, but radially inward of the number ring, on the typical roulette wheel. In addition, a typical roulette wheel includes a circular, inclined ball track, disposed above, and radially outwardly of the number ring.

[0003] In operation of a typical roulette game, players place chips or tokens on the betting layout located on the roulette table, and then the croupier or dealer spins the roulette wheel to place the ball in motion about the circular ball track. As the wheel slows, the ball moves radially inwardly and comes to rest in one of the pockets associated with a particular one of the numbers of the number ring. After the ball comes to rest in one of the pockets, the croupier or dealer settles the various wagers placed on the table layout in accordance with predetermined rules and wager odds and the process repeated.

[0004] In order to reduce costs, automatic roulette wheels have been devised in which the process of putting the ball in play is done automatically, these machines can be made like slot machines with the bets being placed and winnings paid out using a machine rather than a croupier. This reduces the costs associated with security, chips, dealers etc.

[0005] In a known system, in order to recover the ball after each spin, a trap door opens beneath the pockets and the ball drops through this trap door and passes through a series of channels and returned back up to its starting position. The ball can then be put in play by a solenoid firing the ball onto the ball track.

[0006] Another system is disclosed in U.S. Pat. No. 4,735, 416 in which the wheel is displaced relative to a rim and the ball falls into the gap formed and into a return channel under the wheel for returning to its start position.

[0007] Such systems involve the ball disappearing from view and involves complicated machinery to recover the ball and to fire it into play. Such complication requires a great deal maintenance and servicing, particularly to maintain the accuracy of the wheel and the randomness of the winning numbers.

[0008] We have now devised an automatic roulette wheel which reduces these problems.

[0009] According to the invention there is provided a gaming apparatus which comprises a stationary base; a roulette wheel having a rotor rotatably mounted on a vertical axis with respect to the base; the rotor having pockets on its periphery into which a ball can be received with each pocket being associated with a number; a peripheral inclined surface concentric with the rotor for receiving a ball rollably thereon in which the ball will roll into one of the pockets when the ball slows, the said surface comprising a circular, inclined ball track, disposed above, and radially outwardly of the rotor there being means for propelling the ball along the ball track.

[0010] The apparatus is particularly suitable for use in playing roulette but it can be used for any other game which is played on a roulette wheel or roulette type wheel and can include games in which more than one ball is in play during the game.

[0011] The roulette wheel or rotor is able to be rotated in both directions.

[0012] The means for propelling the ball along the said ball track can be a means which can rotate the ball track about a vertical axis in relation to the base. In this case the rotation of the ball track will cause the ball to be rotated as it is located on the ball track.

[0013] Alternatively there can be means which give an impulse to the ball as it is positioned on the ball track, this means can comprise, for example air jets positioned at the edge of the ball track which can direct a jet of air at the ball thus impelling the ball along the ball track. The speed of the ball will cause centrifugal force to cause the ball to move to the outer edge of the ball track where preferably there is a rim to prevent the ball leaving the ball track.

[0014] In use, with a rotatable ball track, at the end of a turn the ball is resting in a pocket and the rotor is rotating slowly or is stationary, the ball track is then rotated until its speed of rotation is the same as that of the rotor, the wheel and the ball track are then rotated together and the ball is ejected from its pocket onto the ball track by the action of centrifugal force and the ball moves onto the ball track and moves to the outside of the ball track. As soon as the ball has left the rotor, the rotor decelerates and is made to turn in the opposite direction. The ball track is then decelerated and the ball then carries on moving by its own momentum and rolls spirally down the ball track towards the rotating rotor as in conventional roulette wheels. The ball then comes to rest in a pocket on the rotor and the rotor slows and can stop and, after settling the bets the process can be repeated.

[0015] In one embodiment preferably there is a releasable holding means whereby the rotor and the ball track can be held together and so they rotate at the same velocity and, when the ball has been ejected from the pocket onto the ball track, the holding means released and the direction of rotation of the rotor reversed.

[0016] The rotor and the ball track can be rotated by means of one or more motors with a timing mechanism so that the successive operational steps can be taken at the appropriate time. There can be a ball stop at the top of the ball track so the ball can be held in position relative to the ball track.

[0017] When there are means which give an impulse to the ball as it is positioned on the ball track, such as air jets

positioned at the edge of the ball track the ball track does not rotate and, in use, at the end of a turn the ball is resting in a pocket and the rotor is rotating slowly or is stationary. The wheel is then accelerated to a speed sufficient to eject the ball from its pocket onto the ball track by the action of centrifugal force and the ball moves onto the ball track and moves to the outside of the ball track. The rotor is then stopped and rotated in the opposite direction. When the ball reaches the outside edge of the ball track it will be held against the rim by the action of centrifugal force and, in order to give an impulse or impulses to the ball jets of compressed gas, such as air, are projected against the ball to keep the ball in position. After a predetermined time the air jets are turned off and the ball then spirals down the ball track to the contra-rotating wheel thus simulating the action of a croupier.

[0018] Preferably there are a plurality of jets positioned around the periphery of the rim of the ball track so that the ball can be propelled along the rim for the required period of time, normally a few seconds and then the jets can be turned off so that the ball will spiral down simulating the action of the croupier.

[0019] Preferably there are air jets positioned to propel a ball in either direction, clockwise or counter clockwise, as croupiers can spin the wheel in either direction and the ball can then circulate around the ball track in the opposite direction to the direction the wheel is rotating. The jets are preferably angled downwardly.

[0020] Without the air jets or other means to propel the ball the ball tends to bounce off the rim and is then thrown back against it in a manner which is unsatisfactory and gives an unrealistic effect.

[0021] Preferably there is a transparent cover such as a glass or transparent plastics cover over the apparatus such as a transparent sheet which fits into the apparatus in the rim above the air jets. This has the effect of improving the action and control of the air jets. The central rotor is then mounted so that it fits beneath the sheet. Above the sheet is preferably a static turret in line with the rotor. This turret preferably has a smooth reflective surface and can be for example in the shape of a cylinder or has a circular cross section of varying diameter along its length i.e. it has a curvilinear shape. In use the numbers or the wheel are reflected in the turret and, as the wheel rotates, the turret has the appearance of movement.

[0022] Preferably there are a plurality of ball stops uniformly located around the peripheral inclined surface; in a typical wheel there can be eight ball stops. In use preferably the operation of the wheel is computer controlled and, by controlling the speed of and the acceleration of the wheel, the ball can be projected up the peripheral surface between any pair of ball stops. This can be chosen at random by the computer.

[0023] In addition to incorporate further random effects the duration of the time the air jets are on and the time to reverse the direction of rotation of the wheel can be random so the is no predictability about the operation of the apparatus.

[0024] The motor is preferably a stepper motor which enable there to be accurate control of its operation and preferably the motor is coupled directly to the rotor e.g. by

friction with a step down gearing to give high torque drive to the rotor and wheel which improves control.

[0025] Optionally the outermost section of the ball track adjacent to the rim is at an angle to the horizontal which is less than that of the rest of the ball track. This means that, in use, less centrifugal force is required to hold the ball against the rim than is required to propel the ball up to the rim. In use, when the ball reaches this outermost section, it will tend to stay against the rim as the ball track slows down or the air jets are turned off and when it leaves this section it will then rapidly spiral down to the wheel and to a pocket.

[0026] Preferred angles of the ball track to the horizontal are ten to thirty degrees and preferred angles of the outer most section is from one to ten degrees to the horizontal with the angle of the outermost section being smaller than the angle of the rest of the ball track.

[0027] A typical angle of the ball track to the horizontal is twenty degrees and a typical angle for this outermost section is five degrees. The width of this outermost section of the ball track is preferably about the diameter of the ball.

[0028] Alternatively the slope of the ball track can change from a greater angle to the horizontal adjacent the wheel to a smaller angle at the outer rim e.g. by the ball track having a curved profile rather than a straight one. The rate of change in angle can be uniform or non uniform. Typically the angle to the horizontal can change from twenty degrees adjacent the wheel to five degrees adjacent the rim.

[0029] There can be a fixed outer rim peripherally outward and at the top of the ball track which can incorporate a ball reader so that the position of the ball in a pocket is automatically noted and recorded. A suitable reader is described in patent application Ser. No. WO 01/32278.

[0030] It is a feature of the present invention that there is no need to affect the structure or operation of the roulette wheel by means of trap doors beneath the pockets or moveable rims in order to recover the ball so that it is easier to maintain the randomness of the wheel and the ball is in sight of the players at all times.

[0031] The invention is useful in conjunction with automatic roulette wheels in which bets are placed via slots or other similar mechanism using coins, notes or tokens and the roulette wheel is spun automatically using the present invention. A payout mechanism can be provided to calculate the winnings and to pay them out in coins, tokens etc. The payout mechanism can include a microprocessor to calculate the amount of winnings on different types of bets, thus enabling completely automatic gaming to take place.

[0032] The invention is described in the accompanying drawing in which:

[0033] FIG. 1 shows a side view of part of a roulette wheel incorporating an embodiment of the invention

[0034] FIGS. 2 and 3 show side views of other embodiment of the invention

[0035] FIGS. 4 and 5 show a plan view the embodiment of FIG. 2

[0036] FIG. 6 shows a schematic view of a section of the ball track

[0037] Referring to **FIG. 1 a** roulette wheel has a rotor (1) mounted on an axle (2) on which is bearing (7). There are pockets (3) on the periphery of the rotor and each pocket is numbered and coloured. Surrounding the rotor (1) is ball track (4) at the top end of which is ball retaining means. The ball track can rotate independently of rotor (1) about axle (2). There is a fixed top rim (5) around the ball track (4) in which there is a number recording device which detects which pocket a ball is in and enables this number to be displayed and recorded. The rotation of the rotor (1) is controlled by motor (9); the rotation of ball track (4) is controlled by motor (10) and the sequence of events controlled by timer (11).

[0038] In use, at the start the ball (6) is in position (a) in pocket (3) the rotor (1) and ball track (4) are spun together and when the rotation of the rotor (1) reaches a certain speed the ball is ejected from pocket by centrifugal force and moves outward until it is in position (b). The ball can then be held there by a ball stop. When the ball leaves the pocket (a) the rotation of rotor (1) is decelerated and reversed.

[0039] Bets can now be made, if not made before, and the ball track (4) slowed down, as the ball track slows down the ball is released from position (b) and spirals down the slope until it lands in a pocket (3) in counter rotating rotor (1). The pocket is noted by detection means (5) as the rotor comes to rest and the bets settled. This process can then be repeated.

[0040] The operation of motors (9) and (10) and the duration of each stage is controlled by a computer/timer (11) so that the operation is completely automatic.

[0041] In sequence the steps are:

[0042] 1. Ball is sitting in a pocket in the rotating rotor as previous game has closed Payouts from previous game have been made and people are now placing bets.

[0043] 2. The computer instructs the ball track to accelerate until its rotational speed has caught up with the rotating rotor.

[0044] 3. When the ball track and rotor are rotating together, they are both accelerated until the ball is thrown outwards from the pocket and on to the ball track by centrifugal force, the ball then moves to the outside of the ball track. There are ball stops positioned in such a way as to push the ball to the outside of the ball track where it meets the top rim.

[0045] 4. Once the ball is on the edge of the ball track it becomes stationary relative to the ball track and, as such, rotates precisely with the ball track.

[0046] 5. As soon as the ball has left the rotor, the rotor decelerates and is made to turn in the opposite direction at a speed at which a casino croupier would generally keep the wheel turning.

[0047] 6. Suddenly the ball track is decelerated and the ball will carry on and will then spin as if it had been fired by the croupier; the ball spirals down in the same way as when fired by a croupier and comes to rest in a pocket in the rotor when payouts etc. can be made and the sequence can be restarted.

[0048] The invention recreates what a croupier does, except that no dealer has had a hand in the procedure. In

particular, in play the ball spins one way and the ball the other way and the ball comes to rest in a pocket as in manually operated games.

[0049] Referring to **FIGS. 2 and 3** a roulette wheel has a rotor (11) mounted on an axle (12). There are pockets (13) on the periphery of the rotor and each pocket is numbered and coloured. Surrounding the rotor (11) is ball track (14). The ball track can rotate independently of rotor (11) about axle (12). There is a fixed top rim (15) around the ball track (14) in which there is a number recording device which detects which pocket a ball is in and enables this number to be displayed and recorded. There are air jets (30) in top rim (5) located as shown in **FIG. 3** and transparent rigid plastics cover (31) over the wheel. The axle (12) stops beneath the cover (31) and there is reflective turret (32) mounted over (12). The rotation of the rotor (11) is controlled by motor and the rotation of ball track is controlled by a motor and the sequence of events controlled by computer. There are ball stops (33) which divide the wheel into sections.

[0050] Referring to **FIGS. 4 and 5** there are air jets positioned on the rim (15) with one set of air jets A directed in one direction and one set of air jets B directed in the opposite direction. The air jets are controlled automatically by a computer. In **FIG. 4 a** possible control system is shown schematically with the air jets operated by solenoids controlled by a computer so the system is automatic and each spin of the rotor is in the opposite direction to the preceding spin.

[0051] In u, at the start the ball (22) is in position 'a' in a pocket (13), the rotor (11) is spun and, when the rotation of the rotor (11) reaches a certain speed, the ball is ejected from the pocket by centrifugal force and moves outward until it is in position 'b'. After the ball leaves the pocket (13) the rotation of rotor (11) is decelerated and reversed. The air jets, directed in the same direction as ball is moving due to the rotation of the rotor which ejected the ball from a pocket, are started and they impart a force to the ball which causes the ball to continue to move around the ball track on or near the rim. The speed of rotation of the wheel is controlled by computer and this speed will determine when the ball is ejected from its pocket and where it hits the rim.

[0052] Bets can now be made, if not made before, the air jets are turned off and the ball releases from the position shown and spirals down the slope until it lands in a pocket (13) in counter rotating rotor (11). The pocket is noted by the detection means as the rotor comes to rest and the bets settled. This process can then be repeated.

[0053] If the rotor is rotated in the opposite direction then the air jets B are operated to cause the ball to circulate on the ball track in the opposite direction.

[0054] In sequence the steps are:

[0055] 1. Ball is sitting in a pocket in the rotating rotor as previous game has closed. Payouts from previous game have been made and people are now placing bets.

[0056] 2. The timer instructs the rotor to rotate and accelerate until the ball is thrown outwards from the pocket and on to the ball track by centrifugal force, the ball then moves to the outside of the ball track.

[0057] 3. One set of air jets are turned on and the ball circulates along the rim of the ball track.

[0058] 4. As soon as the ball has left the rotor, the rotor decelerates and is made to turn in the opposite direction at a speed at which a casino croupier would generally keep the wheel turning.

[0059] 5. Suddenly the air jets are turned off and the ball will carry on and will then spin as if it had been fired by the dealer; the ball spirals down in the same way as when fired by a croupier and comes to rest in a pocket in the rotor when payouts etc. can be made and the sequence can be restarted, with the opposite or same direction of spin of the rotor.

[0060] Referring to FIG. 6 there is an outermost section (18) of ball track (19), the rim (16) and edge (18) are made of a metal, e.g. aluminium, or plastics material. There is an air inlet (20) through which compressed air can be jetted out.

[0061] In use the ball (17) is ejected from the pocket as described above and moves under centrifugal force to the outer edged of ball track (19) and rests against rim (16). When the wheel slows down the air jet is operated to maintain the ball against rim (16) by centrifugal force, when the air jet is turned off the ball spirals down to a pocket as described above.

1. A gaming apparatus which comprises:

- (i) a stationary base;
- (ii) a wheel having a rotor rotatably mounted on a vertical axis with respect to the base, the rotor being able to be rotated in either direction;
- (iii) pockets in the periphery of the rotor for receiving a ball, each pocket being associated with a number;
- (iv) a peripheral inclined surface concentric with the rotor for receiving a ball rollably thereon from the pocket when the rotor is rotated above a pre-set speed and from which the ball will roll into one of the pockets when the rotor slows, the said surface comprising a circular, inclined ball track, disposed above, and radially outwardly of the pockets of rotor;
- (v) means for propelling the ball along the ball track; and
- (vi) a motor for rotating the rotor;

wherein the means for propelling the ball along the ball track comprises at least one air jet positioned at the outer edge of the ball track which can direct a jet of air at the ball thus impelling the ball along the ball track.

2. An apparatus as claimed in claim 1, further comprising a plurality of air jets positioned around the edge of the ball track.

3. An apparatus as claimed in claim 1, wherein there are two or more air jets at least one air jet directed to propel a ball in one direction around the ball track and at least one air jet directed to propel the ball in the opposite direction.

4. An apparatus as claimed in claim 1, including a rim fixed to the outer edge of the ball track and, in use, when the ball reaches the outside edge of the ball track the ball is held against the rim by the action of centrifugal force and there are control means which operate the air jets to give an impulse or impulses of compressed gas to the ball and, after a predetermined time, the air jets can be turned off so the ball then spirals down the ball track to the contra rotating wheel.

5. An apparatus as claimed in claim 1, including a transparent cover over the apparatus which fits into the apparatus in the rim above the at least one air jet.

6. An apparatus as claimed in claim 5, wherein the rotor is mounted so that it fits beneath the sheet and above the sheet is a static turret in line with the rotor which turret has a smooth reflective surface.

7. An apparatus as claimed in claim 1, wherein there are a plurality of ball stops uniformly located around the peripheral inclined surface.

8. An apparatus as claimed in claim 1, including a computer for controlling the operations.

9. An apparatus as claimed in claim 8, wherein the wheel is an automatic wheel which is spun automatically and in which bets are placed via slots or other similar mechanism using coins, notes or tokens or the like.

10. An apparatus as claimed in claim 1, wherein the angle of the ball track to the horizontal is from ten to thirty degrees and the angle of the outermost section is from zero to ten degrees to the horizontal, with the angle of the outermost section being smaller than the angle of the rest of the ball track.

11. An apparatus as claimed in claim 1, wherein there is a releasable holding means whereby the rotor and the ball track can be held together so they rotate at the same velocity, and when the ball has been ejected from the pocket onto the ball track, the holding means released and the direction of rotation of the rotor is reversed.

12. An apparatus as claimed in claim 1, which is a roulette wheel.

13. A gaming apparatus which comprises:

- (vii) a stationary base;
- (viii) a wheel having a rotor rotatably mounted on a vertical axis with respect to the base, the rotor being able to be rotated in either direction;
- (ix) pockets in the periphery of the rotor for receiving a ball, each pocket being associated with a number;
- (x) a peripheral inclined surface concentric with the rotor for receiving a ball rollably thereon from the pocket when the rotor is rotated above a pre-set speed and from which the ball will roll into one of the pockets when the rotor slows, the said surface comprising a circular, inclined ball track, disposed above, and radially outwardly of the pockets of rotor;
- (xi) means for propelling the ball along the ball track; and
- (xii) a motor for rotating the rotor;

wherein the means for propelling the ball along the ball track comprises two or more air jets at least one air jet directed to propel a ball in one direction around the ball track and at least one air jet directed to propel the ball in the opposite direction, said apparatus further comprising a rim fixed to the outer edge of the ball track and, in use, when the ball reaches the outside edge of the ball track the ball is held against the rim by the action of centrifugal force and there are control means which operate the air jets to give an impulse or impulses of compressed gas to the ball and, after a predetermined time, the air jets can be turned off so the ball then spirals down the ball track to the contra rotating wheel.

14. An apparatus as claimed in claim 13, including a transparent cover over the apparatus which fits into the apparatus in the rim above the at least one air jet.

15. An apparatus as claimed in claim 14, wherein the rotor is mounted so that it fits beneath the sheet and above the sheet is a static turret in line with the rotor which turret has a smooth reflective surface.

16. An apparatus as claimed in claim 13, wherein there are a plurality of ball stops uniformly located around the peripheral inclined surface.

17. An apparatus as claimed in claim 13, including a computer for controlling the operations.

18. An apparatus as claimed in claim 17, wherein the wheel is an automatic wheel which is spun automatically and in which bets are placed via slots or other similar mechanism using coins, notes or tokens or the like.

19. An apparatus as claimed in claim 13, wherein the angle of the ball track to the horizontal is preferably from ten to thirty degrees and the angle of the outermost section is preferably from zero to ten degrees to the horizontal, with the angle of the outermost section being smaller than the angle of the rest of the ball track.

20. An apparatus as claimed in claim 13, wherein there is a releasable holding means whereby the rotor and the ball track can be held together so they rotate at the same velocity, and when the ball has been ejected from the pocket onto the ball track, the holding means released and the direction of rotation of the rotor is reversed.

21. An apparatus as claimed in claim 13, which is a roulette wheel.

22. A method of maintaining a ball in motion around a wheel in a gaining device which comprises:

- (i) a stationary base;
- (ii) a wheel having a rotor rotatably mounted on a vertical axis with respect to the base, the rotor being able to be rotated in either direction;
- (iii) pockets in the periphery of the rotor for receiving a ball, each pocket being associated with a number;
- (iv) a peripheral inclined surface concentric with the rotor for receiving a ball rollably thereon from the pocket when the rotor is rotated above a pre-set speed and from which the ball will roll into one of the pockets when the rotor slows, the said surface comprising a circular, inclined ball track, disposed above, and radially outwardly of the pockets of the rotor; and
- (v) a motor for rotating the rotor;

said method comprising the step of maintaining said ball in motion by directing air jets at the ball.

* * * * *